

**FDV Type** ◀ Standard Product

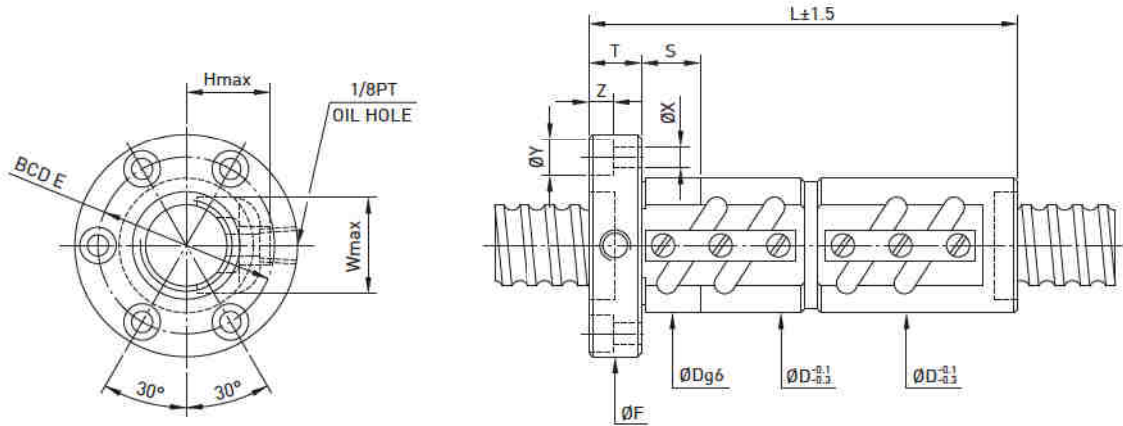

Model	Size		Ball Dia.	PCD	RD	Circuits	Stiffness K (kgf/µm)	Dynamic Load 1x10 <sup>4</sup> revs C (kgf)	Static Load Co (kgf)	Nut		Flange		Return Tube		Bolt			Fit				
	Nominal Dia.	Lead								D	L	F	T	BCD-E	W	H	X	Y		Z	S		
16-5B1	16	5	3.175	16.6	13.324	2.5x1	32	763	1400	31	80	54	12	41	24	22	5.5	9.5	5.5	24			
16-5B2				16.6	13.324	2.5x2	65	1385	2799	31	110	54	12	41	24	22	5.5	9.5	5.5	24			
16-5C1				16.6	13.324	3.5x1	46	1013	1946	31	90	54	12	41	24	22	5.5	9.5	5.5	24			
20-5B1				20	6	3.969	20.6	17.324	2.5x1	38	837	1733	35	80	58	12	46	27	25	5.5	9.5	5.5	24
20-5B2							20.6	17.324	2.5x2	76	1519	3465	35	110	58	12	46	27	25	5.5	9.5	5.5	24
20-6B1							20.8	16.744	2.5x1	40	1139	2187	36	92	60	12	47	28	27	5.5	9.5	5.5	24
20-6C1	20.8	16.744	3.5x1				55	1512	3041	36	104	60	12	47	28	27	5.5	9.5	5.5	24			
25-5B1	25	5	3.175				25.6	22.324	2.5x1	46	939	2209	40	80	64	12	52	31	26	5.5	9.5	5.5	24
25-5B2							25.6	22.324	2.5x2	90	1704	4417	40	110	64	12	52	31	26	5.5	9.5	5.5	24
25-5C1				25.6	22.324	3.5x1	68	1252	3085	40	90	64	12	52	31	26	5.5	9.5	5.5	24			
25-6B2				6	3.969	25.8	21.744	2.5x2	94	2308	5523	42	128	68	12	55	32	28	6.6	11	6.5	24	
25-6C1						25.8	21.744	3.5x1	66	1690	3844	42	104	68	12	55	32	28	6.6	11	6.5	24	
25-10B1						10	4.763	26	21.132	2.5x1	48	1592	3237	45	122	72	16	58	34	29	6.6	11	6.5
28-5B1	28	5	3.175			28.6	25.324	2.5x1	51	984	2466	44	80	70	12	56	34	28	6.6	11	6.5	24	
28-5B2						28.6	25.324	2.5x2	98	1785	4932	44	110	70	12	56	34	28	6.6	11	6.5	24	
28-6A2						6	28.6	25.324	1.5x2	59	1150	2960	44	110	70	12	56	34	28	6.6	11	6.5	24
28-8A2				8	29	24.132	1.5x2	62	1960	4348	50	110	75	12	61	38	32	6.6	11	6.5	15		
28-10B2				10	4.763	29	24.132	2.5x2	102	3060	7299	54	177	94	15	74	37	32	9	14	8.5	30	
32-5B1				32	5	3.175	32.6	29.324	2.5x1	55	1039	2833	50	80	76	12	63	38	30	6.6	11	6.5	24
32-5B2	32.6	29.324	2.5x2				109	1886	5666	50	110	76	12	63	38	30	6.6	11	6.5	24			
32-5C1	32.6	29.324	3.5x1				76	1388	3967	50	90	76	12	63	38	30	6.6	11	6.5	24			
32-6B1	6	3.969	32.8				28.744	2.5x1	57	1409	3510	52	92	78	12	65	39	32	6.6	11	6.5	24	
32-6B2			32.8				28.744	2.5x2	112	2556	7020	52	128	78	12	65	39	32	6.6	11	6.5	24	
32-6C1			32.8				28.744	3.5x1	78	1888	4936	52	104	78	12	65	39	32	6.6	11	6.5	24	
32-8B1			8		4.763	33	28.132	2.5x1	58	1810	4227	54	110	88	16	70	40	33	9	14	8.5	30	
32-8B2						33	28.132	2.5x2	115	3284	8453	54	158	88	16	70	40	33	9	14	8.5	30	
32-8C1						33	28.132	3.5x1	82	2428	5948	54	126	88	16	70	40	33	9	14	8.5	30	
32-10B1	10	6.350				33.4	26.91	2.5x1	58	2651	5600	57	122	91	16	73	44	37	9	14	8.5	30	
32-10B2						33.4	26.91	2.5x2	118	4810	11199	57	182	91	16	73	44	37	9	14	8.5	30	
32-10C1						33.4	26.91	3.5x1	86	3519	7785	57	142	91	16	73	44	37	9	14	8.5	30	
32-12A2			12	6.350	33.4	26.91	1.5x2	72	3035	6555	62	180	108	16	86	44	38	9	14	8.5	15		
32-12B1					33.4	26.91	2.5x1	62	2650	5599	62	138	108	16	86	44	38	9	14	8.5	20		
32-16A2					16	33.4	26.91	1.5x2	72	3035	6555	62	180	108	16	86	44	38	9	14	8.5	20	
36-6B1	36	6			3.969	36.8	32.744	2.5x1	62	1486	3969	55	92	82	12	68	42	32	6.6	11	6.5	24	
36-6B2						36.8	32.744	2.5x2	121	2696	7937	55	128	82	12	68	42	32	6.6	11	6.5	24	
36-10B2						10	6.350	37.4	30.91	2.5x2	132	5105	12669	62	184	104	18	82	49	40	11	17.5	11

Remark : Stiffness values listed above are derived from theoretical formula while preload is 10% of dynamic load rating.

**FDV Type** ◀ Standard Product

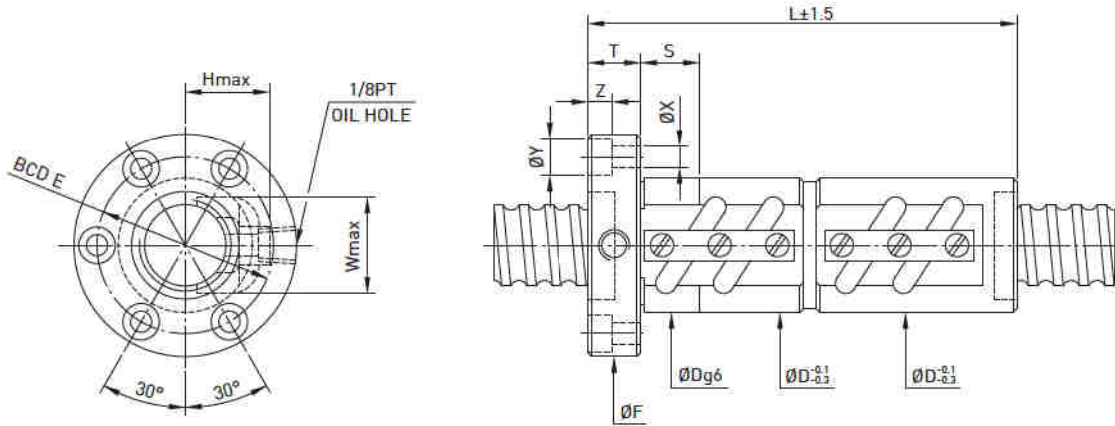

Model	Size		Ball Dia.	PCD	RD	Circuits	Stiffness K (kgf/µm)	Dynamic Load 1x10 <sup>6</sup> revs C (kgf)	Static Load Co (kgf)	Nut		Flange			Return Tube		Bolt			Fit			
	Nominal Dia.	Lead								D	L	F	T	BCD-E	W	H	X	Y	Z		S		
40-5B1	40	5	3.175	40.6	37.324	2.5x1	65	1141	3567	58	84	92	16	72	46	34	9	14	8.5	30			
40-5B2				40.6	37.324	2.5x2	132	2071	7134	58	114	92	16	72	46	34	9	14	8.5	30			
40-6B2		6	3.969	40.8	36.744	2.5x2	136	2817	8855	60	132	94	16	76	47	36	9	14	8.5	30			
40-8B1					41	36.132	2.5x1	69	2003	5302	62	110	96	16	78	48	38	9	14	8.5	30		
40-8B2		8	4.763	41	36.132	2.5x2	137	3634	10603	62	158	96	16	78	48	38	9	14	8.5	30			
40-8C1					41	36.132	3.5x1	96	2679	7438	62	126	96	16	78	48	38	9	14	8.5	30		
40-10B1		10	6.350	41.4	34.91	2.5x1	72	2959	7069	65	132	106	18	85	52	42	11	17.5	11	30			
40-10B2					41.4	34.91	2.5x2	145	5370	14138	65	192	106	18	85	52	42	11	17.5	11	30		
40-10C1					41.4	34.91	3.5x1	102	3932	9841	65	152	106	18	85	52	42	11	17.5	11	30		
40-12A2					12	6.350	41.4	34.91	1.5x2	88	3402	8316	65	160	106	18	84	52	42	11	17.5	11	20
40-12B1								41.6	34.299	2.5x1	70	3425	7837	70	153	112	18	90	55	43	11	17.5	11
40-12B2					12	7.144	41.6	34.299	2.5x2	141	6217	15674	70	225	112	18	90	55	43	11	17.5	11	40
40-12C1								41.6	34.299	3.5x1	103	3932	9841	65	158	106	18	85	52	42	11	17.5	11
40-16A2					16	7.144	41.6	34.299	1.5x2	88	4006	9404	75	209	117	18	95	53	43	11	17.5	11	40
40-16B1		41.6	34.299	2.5x1				118	3425	7837	75	153	117	18	95	53	43	11	17.5	11	40		
40-20A1		20	6.350	41.4				34.91	1.5x1	44	1874	4158	65	152	106	18	85	52	42	11	17.5	11	30
45-10B1	46.4							39.91	2.5x1	76	3116	7953	70	134	112	18	90	58	48	11	17.5	11	30
45-10B2	45	10	6.350	46.4	39.91	2.5x2	156	5655	15905	70	194	112	18	90	58	48	11	17.5	11	30			
45-12B2				7.938	46.8	38.688	2.5x2	162	7627	19799	74	230	122	22	97	60	49	13	20	13	40		
50-5A2	50	5	3.175	50.6	47.324	1.5x2	96	1447	5382	70	107	104	16	86	56	40	9	14	8.5	30			
50-5A3				50.6	47.324	1.5x3	143	2051	8072	70	127	104	16	86	56	40	9	14	8.5	30			
50-5B2		5	3.969	50.6	47.324	2.5x2	153	2245	8969	70	116	104	16	86	56	40	9	14	8.5	30			
50-6B2					50.8	46.744	2.5x2	161	3093	11149	72	134	106	16	88	57	43	9	14	8.5	30		
50-6B3		6	3.969	50.8	46.744	2.5x3	235	4384	16723	72	170	106	16	88	57	43	9	14	8.5	30			
50-8B1					51	46.132	2.5x1	81	2206	6705	75	112	116	18	95	58	45	11	17.5	11	30		
50-8B2		8	4.763	51	46.132	2.5x2	165	4004	13409	75	160	116	18	95	58	45	11	17.5	11	30			
50-8B3					51	46.132	2.5x3	244	5674	20114	75	208	116	18	95	58	45	11	17.5	11	30		
50-10B2		10	6.350	51.4	44.91	2.5x2	173	5923	17670	78	194	119	18	98	62	48	11	17.5	11	30			
50-10B3					51.4	44.91	2.5x3	255	8394	26505	78	254	119	18	98	62	48	11	17.5	11	30		
50-10C1					51.4	44.91	3.5x1	120	4393	12481	78	154	119	18	98	62	48	11	17.5	11	30		
50-12B2					12	7.938	51.8	43.688	2.5x2	178	8022	22094	82	232	130	22	105	64	52	13	20	13	40
50-12C1		51.8	43.688	3.5x1				123	5875	15380	82	184	130	22	105	64	52	13	20	13	40		
55-10C1		55	10	6.350	56.4	49.91	3.5x1	132	4562	13661	84	154	125	18	103	68	54	11	17.5	11	40		
55-12B2					7.938	56.8	48.688	2.5x2	185	8392	24390	88	232	136	22	110	70	56	13	20	13	40	

Remark : Stiffness values listed above are derived from theoretical formula while preload is 10% of dynamic load rating.

**FDV Type** ◀ Standard Product

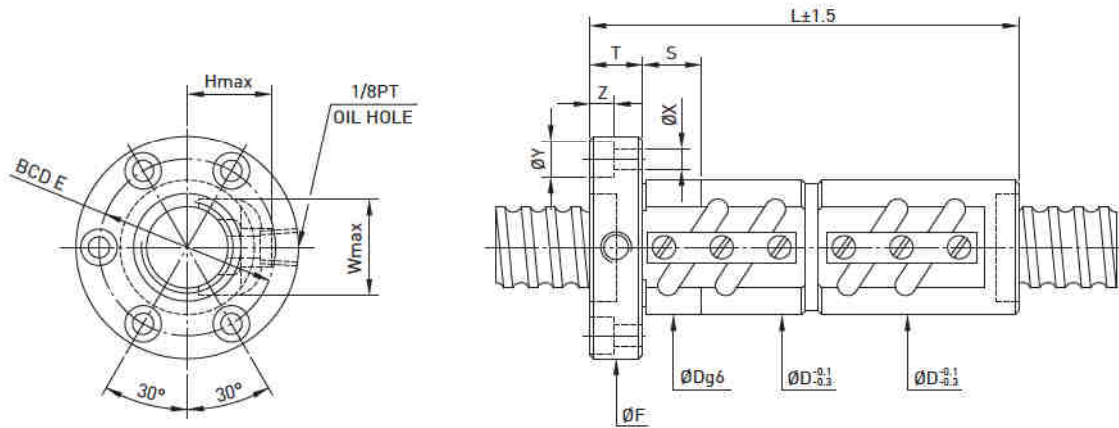

Model	Size		Ball Dia.	PCD	RD	Circuits	Stiffness K (kgf/μm)	Dynamic Load (x10 <sup>4</sup> revs C) (kgf)	Static Load Co (kgf)	Nut		Flange		Return Tube		Bolt			Fit			
	Nominal Dia.	Lead								D	L	F	T	BCD-E	W	H	X	Y		Z	S	
63-8A2	63	8	4.763	64	59.132	1.5x2	107	2826	10129	87	142	129	18	107	70	50	11	17.5	11	40		
63-8A3				64	59.132	1.5x3	154	4004	15193	87	171	129	18	107	70	50	11	17.5	11	40		
63-10B2		10	6.350	64.4	57.91	2.5x2	206	6533	22371	90	196	132	20	110	74	56	11	17.5	11	30		
63-10B3				64.4	57.91	2.5x3	305	9258	33556	90	256	132	20	110	74	56	11	17.5	11	30		
63-12B2				64.8	56.688	2.5x2	214	8943	28062	94	232	142	22	117	76	57	13	20	13	40		
63-16B2				65.2	55.466	2.5x2	280	14862	46009	100	296	150	22	123	78	62	13	20	13	40		
63-20B2	20	9.525	65.2	55.466	2.5x2	280	14862	46009	100	334	150	22	123	78	62	13	20	13	40			
70-10B2	70	10	6.350	71.4	64.91	2.5x2	228	6843	25011	104	196	152	20	128	80	56	13	20	13	40		
70-10B3				71.4	64.91	2.5x3	334	9698	37516	104	256	152	20	128	80	56	13	20	13	40		
70-12B2		12	7.938	71.8	63.688	2.5x2	236	9382	31275	110	232	159	22	133	82	58	13	20	13	40		
70-12B3				71.8	63.688	2.5x3	336	13296	46912	110	302	159	22	133	82	58	13	20	13	40		
80-10B2	80	10	6.350	81.4	74.91	2.5x2	251	7202	28538	115	200	163	22	137	90	64	13	20	13	40		
80-10B3				81.4	74.91	2.5x3	368	10207	42807	115	260	163	22	137	90	64	13	20	13	40		
80-12B2		12	7.938	81.8	73.688	2.5x2	257	9797	35422	120	232	169	22	143	92	67	13	20	13	40		
80-12B3				81.8	73.688	2.5x3	380	13884	53132	120	302	169	22	143	92	67	13	20	13	40		
80-16B2		16	9.525	82.2	72.466	2.5x2	340	16485	58851	125	302	190	28	154	94	70	18	26	17.5	50		
80-16B3				82.2	72.466	2.5x3	498	23363	88276	125	398	190	28	154	94	70	18	26	17.5	50		
80-20B2				20	9.525	82.2	72.466	2.5x2	338	16485	58851	125	345	190	28	154	94	70	18	26	17.5	50
80-20B3						82.2	72.466	2.5x3	498	23363	88276	125	470	190	28	154	94	70	18	26	17.5	50
100-12B2	100	12	7.938	101.8	93.688	2.5x2	301	10761	44596	145	240	209	28	173	112	76	18	26	17.5	50		
100-12B3				101.8	93.688	2.5x3	452	15251	66894	145	312	209	28	173	112	76	18	26	17.5	50		
100-16B2		16	9.525	102.2	92.466	2.5x2	400	18125	74425	150	308	228	32	185	114	80	22	32	21.5	60		
100-16B3				102.2	92.466	2.5x3	595	25684	111637	150	404	228	32	185	114	80	22	32	21.5	60		
100-20B2		20	9.525	102.2	92.466	2.5x2	400	18123	74425	150	350	228	32	185	114	80	22	32	21.5	60		
100-20B3				102.2	92.466	2.5x3	595	25684	111637	150	475	228	32	185	114	80	22	32	21.5	60		

Remark : Stiffness values listed above are derived from theoretical formula while preload is 10% of dynamic load rating.