

FSI Type ◀ Standard Product

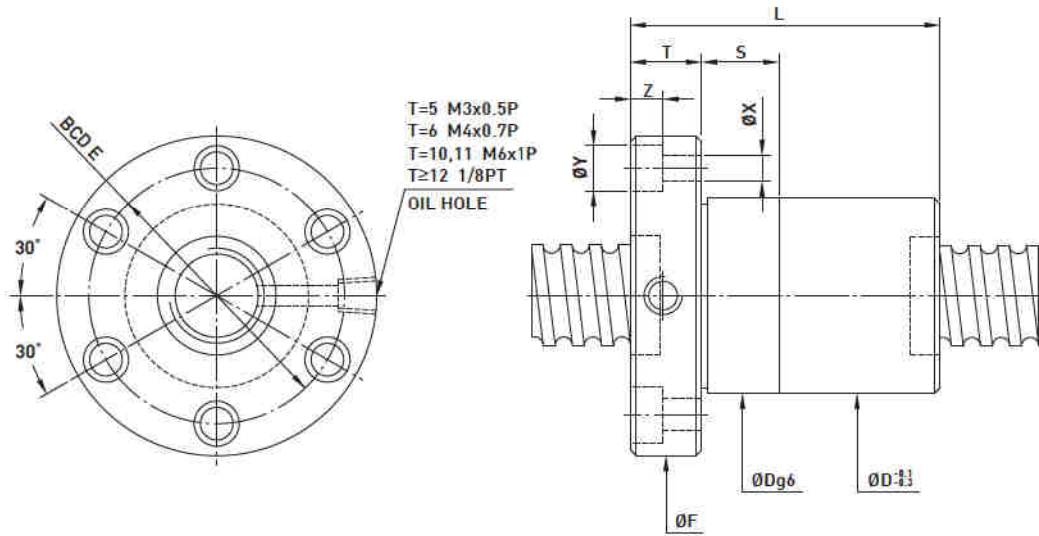

Model	Size		Ball Dia.	PCD	RD	Circuits	Stiffness K (kgf/µm)	Dynamic Load 1x10 ⁶ revs C (kgf)	Static Load Co (kgf)	Nut		Flange			Bolt				Fit
	Nominal Dia.	Lead								D	L	F	T	BCD-E	X	Y	Z	S	
8-2.5T3	8	2.5	1.500	8.2	6.652	3	8	170	267	18	28	35	5	27	4.5	0	0	0	
14-2.54T3	14	2.54	2.000	14.2	12.136	3	12	339	655	30	39	50	10.6	40	5	7	5	0	
14-4T3		4		14.2	12.136	3	12	339	655	26	33	48	6	36	5.5	0	0	0	
16-2T3	16	2	1.500	16.2	14.652	3	14	252	593	27	36	44	10	34	4.5	8	4.5	0	
16-2.5T4		2.5		16.2	14.652	4	19	358	862	27	44	44	10	34	4.5	8	4.5	12	
16-5T3		5	3.175	16.6	13.324	3	11	731	1331	30	46	54	12	41	5.5	9.5	5.5	12	
16-5T4				16.6	13.324	4	12	936	1775	30	52	54	12	41	5.5	9.5	5.5	12	
16-6T4		6	16.6	13.324	4	21	936	1775	32	58	54	12	42	5.5	9.5	5.5	12		
20-2T6		20	2	1.500	20.2	18.652	6	32	518	1551	32	52	52	10	40	5.5	9.5	5.5	12
20-2T4	20.2				18.652	4	36	399	1112	32	40	52	10	40	5.5	9.5	5.5	12	
20-2.5T5	2.5		2.000	20.2	18.136	5	28	637	1635	36	51	59	12	47	5.5	9.5	5.5	12	
20-2.54T6	2.54			20.2	18.136	6	33	745	1962	36	55	59	12	47	5.5	9.5	5.5	12	
20-4T3	4		2.381	20.25	17.792	3	17	509	1134	36	40	59	10	47	5.5	9.5	5.5	12	
20-5T3	5		3.175	20.6	17.324	3	20	852	1767	34	46	57	12	45	5.5	9.5	5.5	12	
20-5T4				20.6	17.324	4	27	1091	2356	34	53	57	12	45	5.5	9.5	5.5	12	
20-6T3	6		3.969	20.8	16.744	3	20	1091	2081	36	51	60	12	48	5.5	9.5	5.5	12	
20-6T4				20.8	16.744	4	27	1398	2774	36	61	60	12	48	5.5	9.5	5.5	12	
20-10T3	10		20.8	16.744	3	20	1091	2080	35	64	57	12	45	5.5	9.5	5.5	12		
25-2T6	25	2	1.500	25.2	23.652	6	39	560	1960	36	50	58	10	46	5.5	9.5	5.5	12	
25-2T4				25.2	23.652	4	27	395	1307	36	40	58	10	46	5.5	9.5	5.5	12	
25-2T3		25.2	23.652	3	20	309	980	36	35	58	10	46	5.5	9.5	5.5	12			
25-2.5T5		2.5	2.000	25.2	23.136	5	34	716	2117	40	52	64	10	51	6.6	11	6.5	12	
25-4T4		4	2.381	25.25	22.792	4	28	747	1989	40	53	64	12	51	5.5	9.5	5.5	12	
25-5T3		5	3.175	25.6	22.324	3	28	977	2314	40	46	63	11	51	5.5	9.5	5.5	10	
25-5T4				25.6	22.324	4	37	1252	3085	40	51	63	11	51	5.5	9.5	5.5	10	
25-5T5		5	3.175	25.6	22.324	5	40	1516	3856	40	56	63	11	51	5.5	9.5	5.5	10	
25-5T6				25.6	22.324	6	48	1773	4627	40	65	63	11	51	5.5	9.5	5.5	10	
25-6T3		6	3.969	25.8	21.744	3	28	1272	2762	42	51	65	12	53	5.5	9.5	5.5	12	
25-6T4	25.8			21.744	4	37	1628	3682	42	61	65	12	53	5.5	9.5	5.5	12		
25-10T3	10	4.763	26	21.132	3	25	1591	3236	45	65	69	15	55	6.6	11	6.5	12		
25-10T4			26	21.132	4	33	2038	4315	45	80	69	15	55	6.6	11	6.5	12		

Remark : Stiffness values listed above value are derived from theoretical formula while axial load is 30% of dynamic load rating without preload.

FSI Type ◀ Standard Product

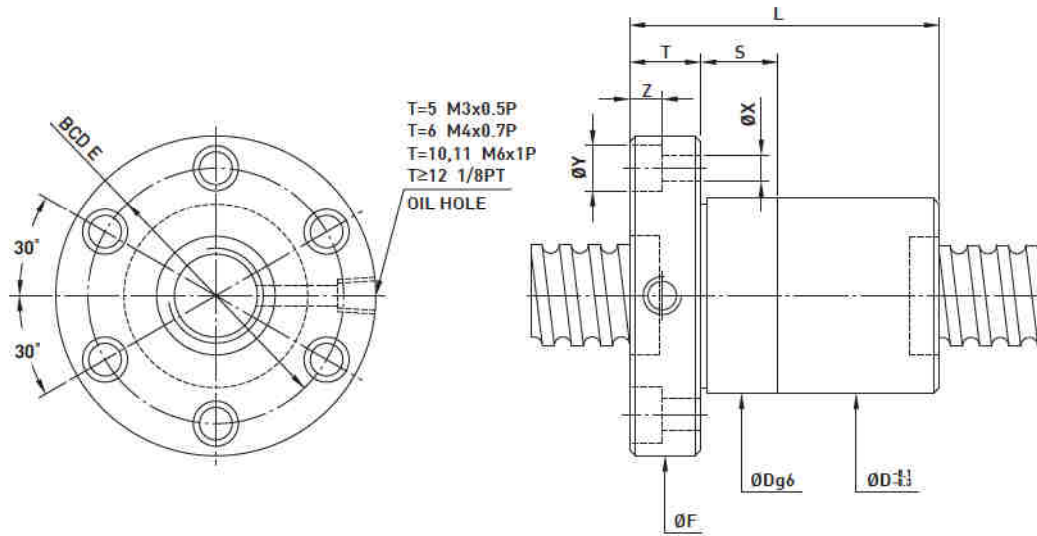

Model	Size		Ball Dia.	PCD	RD	Circuits	Stiffness K (kgf/μm)	Dynamic Load 1x10 ⁶ revs C (kgf)	Static Load Co (kgf)	Nut		Flange			Bolt			Fit		
	Nominal Dia.	Lead								D	L	F	T	BCD-E	X	Y	Z		S	
32-5T3	32	5	3.175	32.6	29.324	3	33	1117	3081	44	48	46	74	12	60	6.6	11	6.5	12	
32-5T4				32.6	29.324	4	42	1431	4108	44	48	53	74	12	60	6.6	11	6.5	12	
32-5T6		6	3.969	32.6	29.324	6	63	2027	6162	44	48	66	74	12	60	6.6	11	6.5	12	
32-6T3				32.8	28.744	3	33	1446	3620	45	50	51	76	12	62	6.6	11	6.5	12	
32-6T4		6	3.969	3.969	32.8	28.744	4	43	1852	4826	45	50	61	76	12	62	6.6	11	6.5	12
32-6T6					32.8	28.744	6	65	2625	7239	45	50	75	76	12	62	6.6	11	6.5	12
32-8T3		8	4.763	4.763	33	28.132	3	35	1810	4227	47	52	63	78	16	64	6.6	11	6.5	12
32-8T4					33	28.132	4	47	2317	5635	47	52	74	78	16	64	6.6	11	6.5	12
32-10T3		10	6.350	6.350	33.4	26.91	3	35	2539	5327	51	56	72	82	16	68	6.6	11	6.5	12
32-10T4					33.4	26.91	4	48	3252	7102	51	56	83	82	16	68	6.6	11	6.5	12
40-5T4	40	5	3.175	40.6	37.324	4	50	1599	5280	51	54	53	80	16	66	6.6	11	6.5	12	
40-5T6				40.6	37.324	6	74	2265	7919	51	54	66	80	16	66	6.6	11	6.5	12	
40-5.08T6		5.08	3.175	40.6	37.324	6	74	2265	7919	53	56	65	90	15	72	9	14	8.5	15	
40-6T4		6	3.969	3.969	40.8	36.744	4	50	2136	6420	53	56	65	88	16	72	9	14	8.5	15
40-6T6					40.8	36.744	6	74	3028	9630	53	56	79	88	16	72	9	14	8.5	15
40-8T4		8	4.763	4.763	41	36.132	4	52	2728	7596	55	60	78	92	16	75	9	14	8.5	15
40-8T6					41	36.132	6	76	3866	11394	55	60	99	92	16	75	9	14	8.5	15
40-10T3		10	6.350	6.350	41.4	34.91	3	40	2959	7069	60	65	76	96	16	80	9	14	8.5	15
40-10T4					41.4	34.91	4	51	3789	9426	60	65	87	96	16	80	9	14	8.5	15
50-5T4		50	5	3.175	50.6	47.324	4	62	1757	6745	62	65	57	96	16	80	9	14	8.5	15
50-5T6	50.6				47.324	6	91	2490	10117	62	65	70	96	16	80	9	14	8.5	15	
50-6T4	6		3.969	3.969	50.8	46.744	4	62	2388	8250	64	68	65	100	16	84	9	14	8.5	15
50-6T6					50.8	46.744	6	93	3384	12375	64	68	79	100	16	84	9	14	8.5	15
50-8T4	8		4.763	4.763	51	46.132	4	62	2998	9578	65	70	78	102	16	85	9	14	8.5	15
50-8T6					51	46.132	6	92	4249	14367	65	70	99	102	16	85	9	14	8.5	15
50-10T3	10		6.350	6.350	51.4	44.91	3	50	3397	9256	69	74	78	114	18	92	11	17.5	11	20
50-10T4					51.4	44.91	4	63	4350	12341	69	74	89	114	18	92	11	17.5	11	20
50-10T6	10		6.350	6.350	51.4	44.91	6	94	6165	18511	69	74	112	114	18	92	11	17.5	11	20
50-12T3					12	7.938	7.938	51.8	43.688	3	50	4420	11047	73	78	90	118	18	96	11
50-12T4	51.8	43.688	4	63				5660	14730	73	78	103	118	18	96	11	17.5	11	20	
50-20T4	20	9.525	9.525	52.2	42.466	4	80	9327	23955	75	78	186	129	28	105	14	20	13	30	

Remark : Stiffness values listed above value are derived from theoretical formula while axial load is 30% of dynamic load rating without preload.

FSI Type ◀ Standard Product

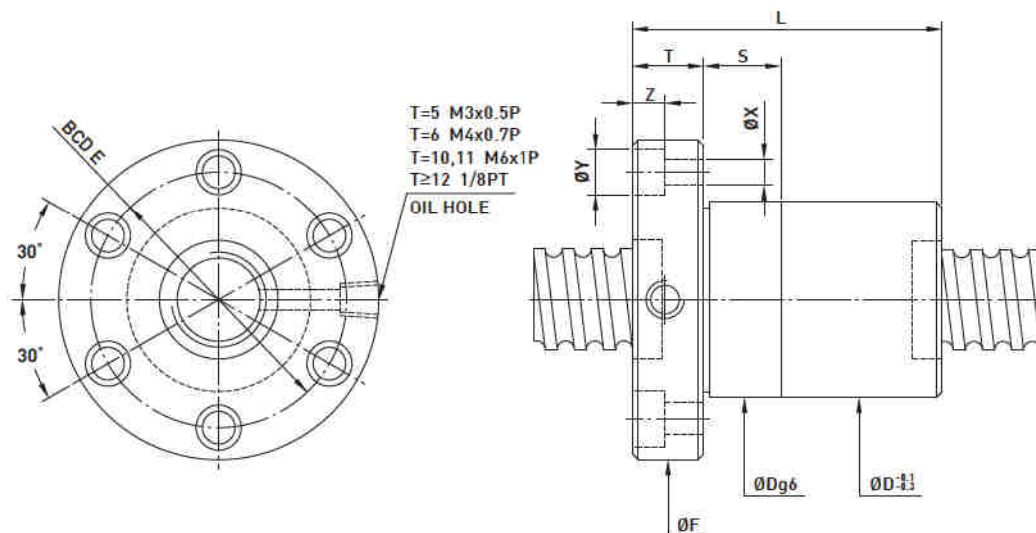

Model	Size		Ball Dia.	PCD	RD	Circuits	Stiffness K (kgf/µm)	Dynamic Load 1×10^4 revs C (kgf)	Static Load Co (kgf)	Nut		Flange			Bolt			Fit	
	Nominal Dia.	Lead								D	L	F	T	BCD-E	X	Y	Z		S
63-6T4	63	6	3.969	63.8	59.744	4	75	2614	10542	78	80	66	119	18	98	11	17.5	11	20
63-6T6				63.8	59.744	6	113	3704	15813	78	80	81	119	18	98	11	17.5	11	20
63-8T4		8	4.763	64	59.132	4	77	3395	12541	79	82	80	122	18	100	11	17.5	11	20
63-8T6				64	59.132	6	114	4812	18811	79	82	101	122	18	100	11	17.5	11	20
63-10T4		10	6.350	64.4	57.91	4	79	4860	15858	82	88	91	134	20	110	14	20	13	20
63-10T6				64.4	57.91	6	115	6887	23786	82	88	114	134	20	110	14	20	13	20
63-12T4	12	7.938	64.8	56.688	4	78	6479	19293	86	92	105	138	20	114	14	20	13	20	
63-12T6			64.8	56.688	6	113	9182	28939	86	92	133	138	20	114	14	20	13	20	
80-10T4	80	10	6.350	81.4	74.91	4	96	5559	21118	99	105	91	152	20	127	14	20	13	20
80-10T6				81.4	74.91	6	140	7879	31677	99	105	114	152	20	127	14	20	13	20
80-12T4		12	7.938	81.8	73.688	4	97	7430	25681	103	110	109	170	24	138	18	26	17.5	25
80-12T6				81.8	73.688	6	141	10530	38521	103	110	137	170	24	138	18	26	17.5	25
80-16T3		16	9.525	82.2	72.466	3	95	9663	31622	108	115	118	174	24	143	18	26	17.5	25
80-16T4				82.2	72.466	4	130	12375	42162	108	115	136	174	24	143	18	26	17.5	25
80-20T3	20	9.525	82.2	72.466	3	95	9663	31622	108	115	138	174	24	143	18	26	17.5	25	
80-20T4			82.2	72.466	4	125	12375	42162	108	115	161	174	24	143	18	26	17.5	25	
100-12T4	100	12	7.938	101.8	93.688	4	105	8306	33001	123	130	109	190	24	158	18	26	17.5	25
100-12T6				101.8	93.688	6	175	11772	49502	123	130	137	190	24	158	18	26	17.5	25
100-16T4		16	9.525	102.2	92.466	4	107	13569	53161	125	135	136	194	24	163	18	26	17.5	30
100-16T6				102.2	92.466	6	140	19230	79741	125	135	173	194	24	163	18	26	17.5	30
100-20T4		20	9.525	102.2	92.466	4	155	13569	53161	125	135	161	194	24	163	18	26	17.5	30

Remark : Stiffness values listed above value are derived from theoretical formula while axial load is 30% of dynamic load rating without preload.