

PFDI Type ◀ Standard Product

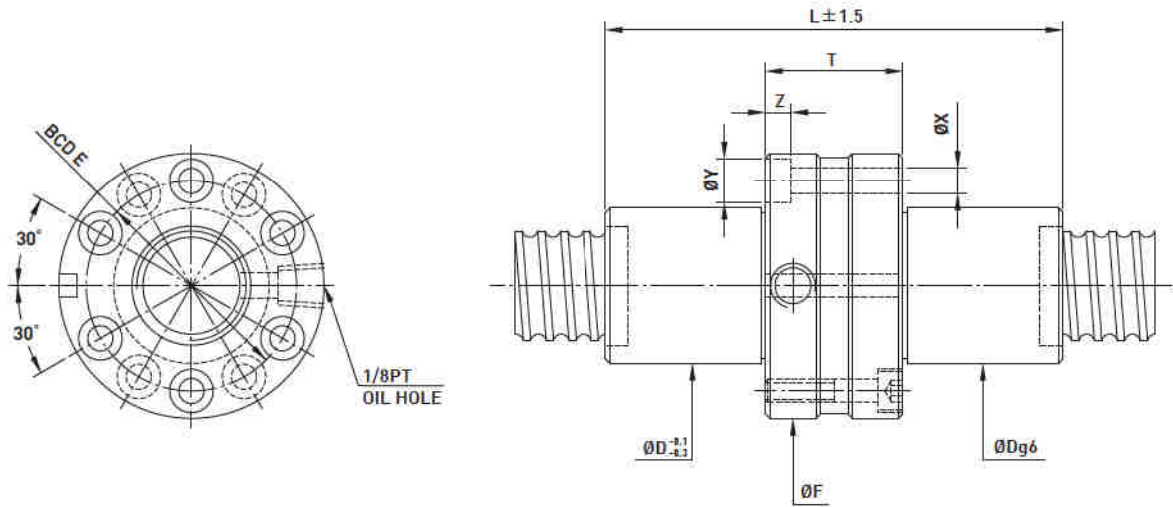
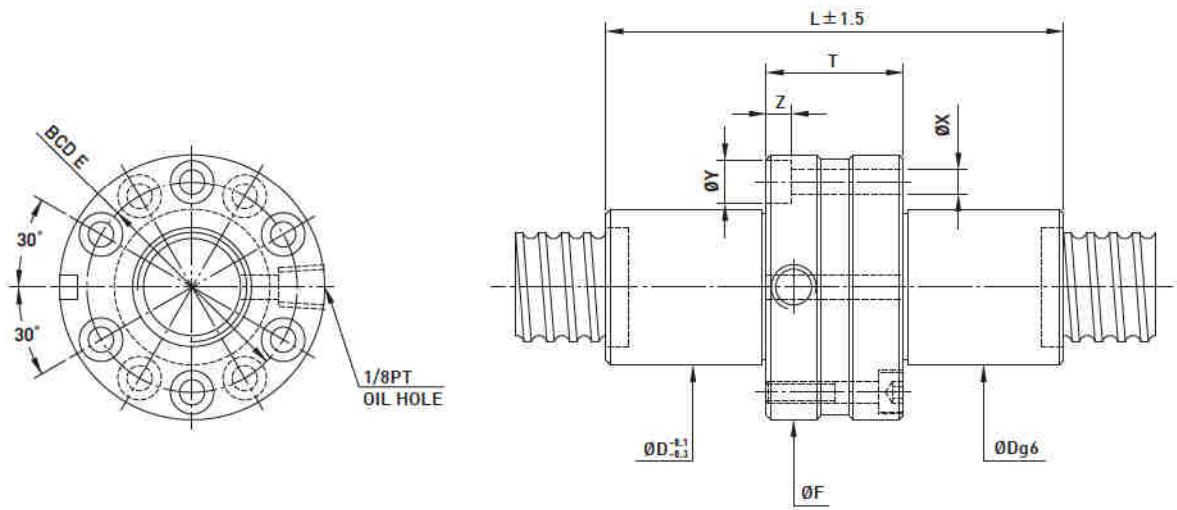

Model	Size		Ball Dia.	PCD	RD	Circuits	Stiffness K (kgf/µm)	Dynamic Load 1x10 ⁶ revs C (kgf)	Static Load Co (kgf)	Nut		Flange			Bolt		
	Nominal Dia.	Lead								D	L	F	T	BCD-E	X	Y	Z
20-5T3	20	5	3.175	20.6	17.324	3	39	852	1767	34	100	58	30	46	5.5	9.5	5.5
20-5T4				20.6	17.324	4	54	1091	2356	34	110	58	30	46	5.5	9.5	5.5
20-6T3		6	3.969	20.8	16.744	3	39	1091	2081	36	111	58	29	46	5.5	9.5	5.5
20-6T4				20.8	16.744	4	54	1398	2774	36	127	58	29	46	5.5	9.5	5.5
25-5T3	25	5	3.175	25.6	22.324	3	55	977	2314	40	100	63	30	51	5.5	9.5	5.5
25-5T4				25.6	22.324	4	73	1252	3085	40	110	63	30	51	5.5	9.5	5.5
25-6T3		6	3.969	25.8	21.744	3	56	1272	2762	40	111	63	29	51	5.5	9.5	5.5
25-6T4				25.8	21.744	4	75	1628	3682	40	127	63	29	51	5.5	9.5	5.5
32-5T3	32	5	3.175	32.6	29.324	3	64	1117	3081	48	100	75	30	61	6.6	11	6.5
32-5T4				32.6	29.324	4	82	1431	4108	48	110	75	30	61	6.6	11	6.5
32-6T3		6	3.969	32.8	28.744	3	65	1446	3620	50	111	75	29	61	6.6	11	6.5
32-6T4				32.8	28.744	4	84	1852	4826	50	127	75	29	61	6.6	11	6.5
32-8T3		8	4.763	33	28.132	3	68	1810	4227	52	139	84	35	68	9	14	8.5
32-8T4				33	28.132	4	82	2317	5635	52	157	84	35	68	9	14	8.5
32-10T3		10	6.350	33.4	26.91	3	68	2539	5327	56	165	88	35	70	9	14	8.5
32-10T4				33.4	26.91	4	82	3252	7102	56	185	88	35	70	9	14	8.5
40-5T4	40	5	3.175	40.6	37.324	4	99	1599	5280	54	115	90	35	72	9	14	8.5
40-5T6				40.6	37.324	6	146	2265	7919	54	135	90	35	72	9	14	8.5
40-6T4		6	3.969	40.8	36.744	4	100	2136	6420	56	133	90	35	72	9	14	8.5
40-6T6				40.8	36.744	6	148	3028	9630	56	157	90	35	72	9	14	8.5
40-8T4		8	4.763	41	36.132	4	102	2728	7596	60	157	94	35	76	9	14	8.5
40-8T6				41	36.132	6	150	3866	11394	60	191	94	35	76	9	14	8.5
40-10T3		10	6.350	41.4	34.91	3	76	2529	7069	62	175	104	45	82	11	17.5	11
40-10T4				41.4	34.91	4	101	3789	9426	62	195	104	45	82	11	17.5	11
50-5T4	50	5	3.175	50.6	47.324	4	121	1757	6745	65	115	100	35	82	9	14	8.5
50-5T6				50.6	47.324	6	177	2490	10117	65	135	100	35	82	9	14	8.5
50-6T4		6	3.969	50.8	46.744	4	123	2388	8250	68	136	100	38	82	9	14	8.5
50-6T6				50.8	46.744	6	179	3384	12375	68	160	100	38	82	9	14	8.5
50-8T4		8	4.763	51	46.132	4	122	2998	9578	70	165	112	43	90	11	17.5	11
50-8T6				51	46.132	6	178	4249	14367	70	199	112	43	90	11	17.5	11
50-10T3		10	6.350	51.4	44.91	3	95	3397	9256	74	175	114	45	92	11	17.5	11
50-10T4				51.4	44.91	4	124	4350	12341	74	195	114	45	92	11	17.5	11
50-10T6		10	6.350	51.4	44.91	6	184	6165	18511	74	235	114	43	92	11	17.5	11
50-12T3				12	7.938	51.8	43.688	3	94	4420	11047	75	203	121	49	97	14
50-12T4		51.8	43.688			4	124	5660	14730	75	227	121	49	97	14	20	13

Remark : Stiffness values listed above are derived from theoretical formula while preload is 10% of dynamic load rating.

PFDI Type ◀ Standard Product

Model	Size		Ball Dia.	PCD	RD	Circuits	Stiffness K (kgf/μm)	Dynamic Load 1×10^6 revs C (kgf)	Static Load Co (kgf)	Nut		Flange			Bolt			
	Nominal Dia.	Lead								D	L	F	T	BCD-E	X	Y	Z	
63-6T4	63	6	3.969	63.8	59.744	4	148	2614	10542	80	142	122	44	100	11	17.5	11	
63-6T6				63.8	59.744	6	220	3704	15813	80	166	122	44	100	11	17.5	11	
63-8T4		8	4.763	64	59.132	4	152	3395	12541	82	165	124	43	102	11	17.5	11	
63-8T6				64	59.132	6	222	4812	18811	82	199	124	43	102	11	17.5	11	
63-10T4		10	6.350	6.350	64.4	57.91	4	158	4860	15858	85	205	131	55	107	14	20	13
63-10T6					64.4	57.91	6	228	6887	23786	85	245	131	53	107	14	20	13
63-12T4	12		7.938	7.938	64.8	56.688	4	152	6479	19293	90	230	136	52	112	14	20	13
63-12T6					64.8	56.688	6	224	9182	28939	90	280	136	52	112	14	20	13
80-10T4	80	10	6.350	81.4	74.91	4	190	5559	21118	105	205	151	55	127	14	20	13	
80-10T6				81.4	74.91	6	277	7879	31677	105	245	151	53	127	14	20	13	
80-12T4		12	7.938	7.938	81.8	73.688	4	192	7430	25681	110	230	156	52	132	14	20	13
80-12T6					81.8	73.688	6	280	10530	38521	110	280	156	52	132	14	20	13
80-20T3		20	9.525	9.525	82.2	72.466	3	189	9663	31622	115	301	173	65	143	18	26	17.5
80-20T4					82.2	72.466	4	248	12375	42162	115	346	173	66	143	18	26	17.5
100-10T6	100	10	6.350	101.4	94.91	6	236	8662	40469	125	245	171	53	147	14	20	13	
100-12T6		12	7.938	102.2	92.466	6	343	19230	79741	130	292	188	64	158	18	26	17.5	
100-20T4		20	9.525	102.2	92.466	4	300	13569	53161	135	356	205	76	169	22	32	21.5	

Remark : Stiffness values listed above are derived from theoretical formula while preload is 10% of dynamic load rating.