

PFDW Type 1 ◀ Standard Product

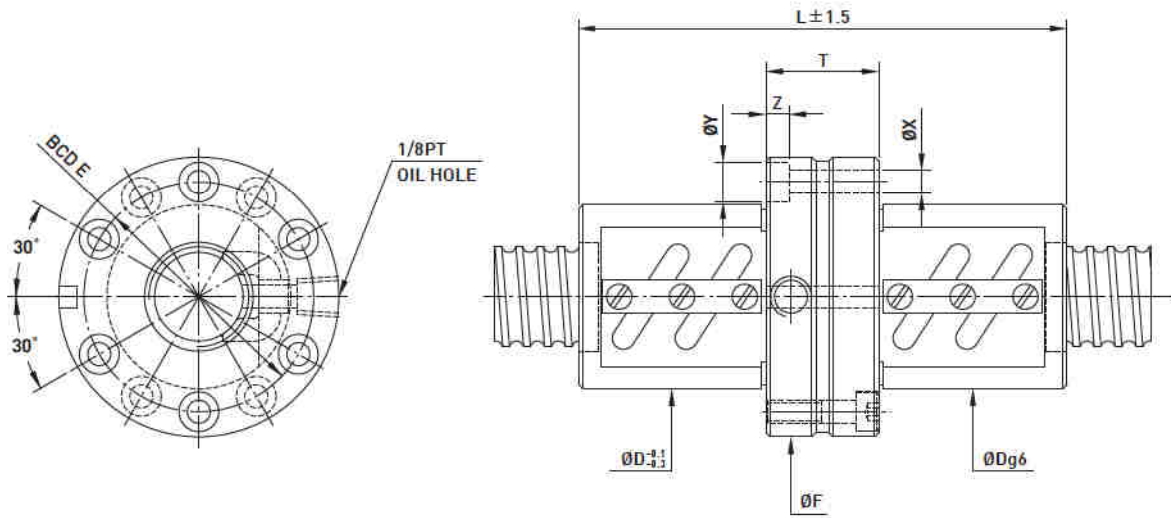

Model	Size		Ball Dia.	PCD	RD	Circuits	Stiffness K (kgf/µm)	Dynamic Load 1×10^4 revs C (kgf)	Static Load Co (kgf)	Nut		Flange			Bolt		
	Nominal Dia.	Lead								D	L	T	F	BCD-E	X	Y	Z
20-5B1	20	5	3.175	20.6	17.324	2.5x1	38	837	1733	44	87	27	67	55	5.5	9.5	5.5
20-5B2				20.6	17.324	2.5x2	76	1519	3465	44	117	27	67	55	5.5	9.5	5.5
20-6B1		6	3.969	20.8	16.744	2.5x1	40	1139	2187	48	95	29	71	59	5.5	9.5	5.5
20-6C1				20.8	16.744	3.5x1	55	1512	3041	48	107	29	71	59	5.5	9.5	5.5
25-5B1	25	5	3.175	25.6	22.324	2.5x1	46	939	2209	50	86	28	73	61	5.5	9.5	5.5
25-5B2				25.6	22.324	2.5x2	90	1704	4417	50	116	28	73	61	5.5	9.5	5.5
25-5C1		6	3.969	25.6	22.324	3.5x1	68	1252	3085	50	96	28	73	61	5.5	9.5	5.5
25-6B2				25.8	21.744	2.5x2	94	2308	5523	56	131	29	82	69	5.5	9.5	5.5
25-6C1	25.8	21.744	3.5x1	66	1690	2844	56	107	29	82	69	5.5	9.5	5.5			
32-5B1	32	5	3.175	32.6	29.324	2.5x1	55	1039	2833	58	91	33	85	71	6.6	11	6.5
32-5B2				32.6	29.324	2.5x2	109	1886	5666	58	121	33	85	71	6.6	11	6.5
32-6B1		6	3.969	32.8	28.744	2.5x1	57	1409	3510	62	95	29	89	75	6.6	11	6.5
32-6B2				32.8	28.744	2.5x2	112	2556	7020	62	131	29	89	75	6.6	11	6.5
32-8B1		8	4.763	33	28.132	2.5x1	58	1810	4227	66	125	39	100	82	9	14	8.5
32-8B2				33	28.132	2.5x2	115	3284	8453	66	173	39	100	82	9	14	8.5
32-10B1		10	6.350	33.4	26.91	2.5x1	58	2651	5600	74	185	38	108	90	9	14	8.5
32-10B2				33.4	26.91	2.5x2	118	4810	11199	74	208	38	108	90	9	14	8.5
32-10C1	33.4	26.91	3.5x1	86	3519	7785	74	168	38	108	90	9	14	8.5			
40-5B1	40	5	3.175	40.6	37.324	2.5x1	65	1141	3567	68	96	38	101	83	9	14	8.5
40-5B2				40.6	37.324	2.5x2	132	2071	7134	68	126	38	101	83	9	14	8.5
40-6B1		6	3.969	40.8	36.744	2.5x1	67	1552	4428	70	101	35	104	86	9	14	8.5
40-6B2				40.8	36.744	2.5x2	136	2817	8855	70	137	35	104	86	9	14	8.5
40-8B1		8	4.763	41	36.132	2.5x1	69	2003	5302	74	125	39	108	90	9	14	8.5
40-8B2				41	36.132	2.5x2	137	3634	10603	74	173	39	108	90	9	14	8.5
40-10B1		10	6.350	41.4	34.91	2.5x1	72	2959	7069	84	158	48	124	102	11	17.5	11
40-10B2				41.4	34.91	2.5x2	145	5370	14138	84	218	48	124	102	11	17.5	11
40-10C1		41.4	34.91	3.5x1	102	3932	9841	84	178	48	124	102	11	17.5	11		
40-12B1		12	7.144	41.6	34.299	2.5x1	70	3425	7837	86	174	48	128	106	11	17.5	11
40-12B2				41.6	34.299	2.5x2	141	6217	15674	86	246	48	128	106	11	17.5	11

Remark : Stiffness values listed above are derived from theoretical formula while preload is 10% of dynamic load rating.

PFDW Type 1 ◀ Standard Product

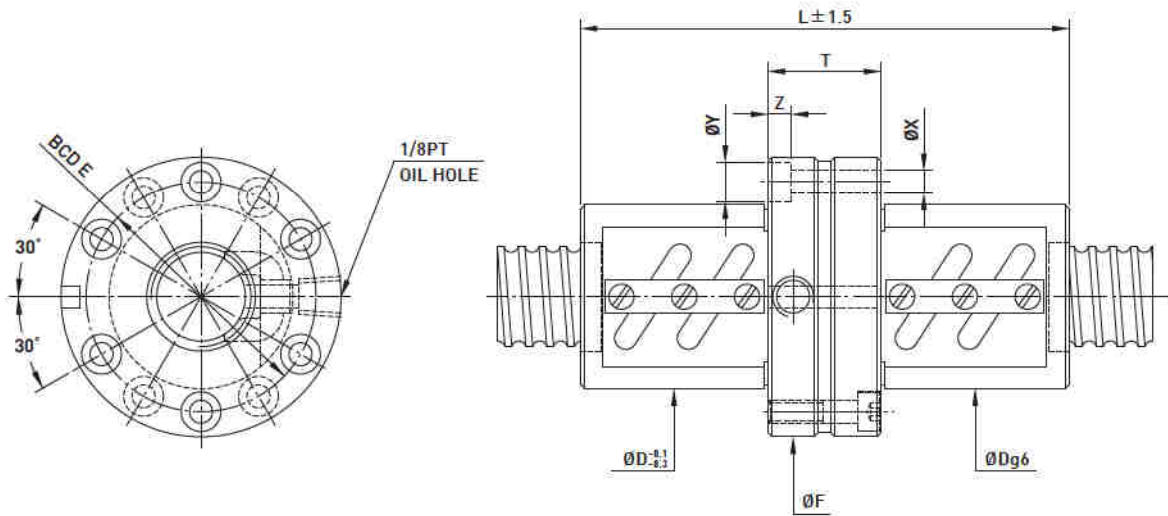

Model	Size		Ball Dia.	PCD	RD	Circuits	Stiffness K (kgf/μm)	Dynamic Load 1×10^4 revs C (kgf)	Static Load Co (kgf)	Nut		Flange			Bolt		
	Nominal Dia.	Lead								D	L	T	F	BCD-E	X	Y	Z
50-8B1	50	8	4.763	51	46.132	2.5x1	81	2206	6705	87	133	47	129	107	11	17.5	11
50-8B2				51	46.132	2.5x2	165	4004	13409	87	181	47	129	107	11	17.5	11
50-10B1		10	6.350	51.4	44.91	2.5x1	87	3264	8835	94	158	48	135	113	11	17.5	11
50-10B2				51.4	44.91	2.5x2	173	5923	17670	94	218	48	135	113	11	17.5	11
50-12B2		12	7.938	51.8	43.688	2.5x2	178	8022	22094	102	260	58	146	122	14	20	13
50-12C1					43.688	3.5x1	123	5875	15380	102	200	58	146	122	14	20	13
63-10B2	63	10	6.350	64.4	57.91	2.5x2	206	6533	22371	110	228	58	154	130	14	20	13
63-10B3				64.4	57.91	2.5x3	305	9258	33556	110	288	58	154	130	14	20	13
63-12B2		12	7.938	64.8	56.688	2.5x2	214	8943	28062	118	260	58	166	141	14	20	13
80-12B2	81.8				73.688	2.5x2	257	9797	35422	136	260	58	185	159	14	20	13
80-12B3	80	20	9.525	81.8	73.688	2.5x3	380	13884	53132	136	340	58	185	159	14	20	13
80-20B2				82.2	72.466	2.5x2	338	16485	58851	145	404	66	204	172	18	26	17.5
100-20B2	100			102.2	92.466	2.5x2	400	18123	74425	170	404	86	243	205	22	32	21.5

Remark : Stiffness values listed above are derived from theoretical formula while preload is 10% of dynamic load rating.