

Non-standard motors frame size 315 and above



3/2	Orientation	3/34	Self-ventilated motors with through ventilation for mains-fed operation Cast-iron series 1LL8
3/2	Overview	3/34	Selection and ordering data
3/2	Benefits		
3/3	Application		
3/3	Design		
3/4	Technical specifications		
3/11	Selection and ordering data		
3/13	More information		
3/14	Self-ventilated motors for mains-fed operation Cast-iron series 1LA8	3/38	Self-ventilated motors with through ventilation for converter-fed operation Cast-iron series 1LL8
3/14	Selection and ordering data	3/38	Selection and ordering data
3/18	Self-ventilated motors for converter-fed operation Cast-iron series 1LA8	3/46	Special versions
3/18	Selection and ordering data	3/46	Overview
		3/47	Selection and ordering data
		3/47	• Voltages
		3/50	• Options
3/26	Forced-air cooled motors with separately driven fan for converter-fed operation Cast-iron series 1PQ8	3/62	Accessories
3/26	Selection and ordering data	3/62	Overview
		3/62	More information
		3/63	Dimensions
		3/63	Overview
		3/64	Dimensional drawings

IEC Squirrel-Cage Motors

Non-standard motors frame size 315 and above

Orientation

Overview



N compact three-phase asynchronous motors: Series 1LA8, 1PQ8, 1LL8

The three-phase motor series N compact covers outputs up to 1250 kW (at 50 Hz) in the non-standard range. A number of technical features provide this motor series with its ruggedness and long service life and ensure the highest level of availability.

N compact motors are also characterised by their high output for small frame size. The consequence of this is an extremely compact design that can be used to save space in a number of industrial applications.

N compact motors are not only optimised in terms of their construction, but also in terms of their efficiency, so they also contribute towards lower energy consumption.

Apart from mains-fed operation, the motors of the series N compact are also specially designed for converter-fed operation. In combination with frequency converters from the SINAMICS and SIMOVERT MASTERDRIVES product series, they build up perfectly interacting drive systems for variable-speed drive applications.

Versions in the N compact series

Series 1LA8

The motors are asynchronous squirrel-cage motors with compact dimensions in fin-cooled design. They are designed for direct connection to the three-phase supply and for converter-fed operation.

- *1LA8 for mains-fed operation*
 - Designed for operation on the three-phase supply
 - Degree of protection: IP55
 - Cooling method: IC411, self-ventilated
 - Housing: Cast iron

- *1LA8 for converter-fed operation*
 - Converter-fed operation, optimised for the SINAMICS and SIMOVERT MASTERDRIVES drive systems
 - Degree of protection: IP55
 - Cooling method: IC411, self-ventilated
 - Housing: Cast iron
 - With standard insulation for voltages ≤ 500 V or with special insulation for 690 V

Series 1PQ8

The motors are asynchronous squirrel-cage motors with compact dimensions in fin-cooled design with forced ventilation. As these motors are forced-ventilated, no derating or only relatively minor derating (depending on their speed range) is required for operation at constant load torque and with wide speed ranges. The motors are designed for converter-fed operation with the SINAMICS and SIMOVERT MASTERDRIVES drive system.

- Converter-fed operation
- Degree of protection: IP55
- Cooling method: IC416, forced-ventilated
- Housing: Cast iron
- With standard insulation for voltages ≤ 500 V or with special insulation for 690 V

Series 1LL8

The motors of series 1LL8 are asynchronous squirrel-cage motors with compact dimensions in an open fin-cooled design with self-cooling. They are similar in construction to 1LA8 motors. IP23 degree of protection is achieved by opening the internal cooling circuit and supplying it with external cooling air. This can increase the performance by up to 25 % as compared to the 1LA8. They are designed for direct connection to the three-phase supply and for converter-fed operation.

Motors of the 1LL8 type series are intended for installation indoors. They must not be subjected to humid, salty or corrosive atmospheres.

- *1LL8 for mains-fed operation*
 - Mains-fed operation
 - Degree of protection: IP23
 - Cooling method: IC01, self-ventilated
 - Housing: Cast iron
- *1LL8 for converter-fed operation*
 - Converter-fed operation
 - Degree of protection: IP23
 - Cooling method: IC01, self-ventilated
 - Housing: Cast iron

Versions with special insulation for >500 V and operation without an output filter on the frequency converter are only possible on request.

Benefits

Non-standard motors from Siemens offer the user numerous advantages:

- The optimised efficiency results in lower operating costs.
- The high output/size ratio ensures low space requirements combined with low weight.
- The cast-iron housing and bearing plates are extremely rigid and rugged and can therefore be subjected to considerable stress and have excellent vibration damping properties and are resistant to corrosion.
- The bearings are designed for maximum reliability, which results in good vibration characteristics, a long service life and low maintenance costs.
- The DURIGNIT IR 2000 insulation system with VPI or current-UV impregnation results in high reliability, a long service life and high resistance to stress, for example, during starting or under overload conditions.
- Due to the low noise emission level, the stringent requirements of worker protection are fulfilled without the need for additional measures.

IEC Squirrel-Cage Motors

Non-standard motors frame size 315 and above

Orientation

Application

Thanks to the many options, the three-phase motor series N compact covers applications in a wide range of different sectors: Chemicals, paper, water/waste water, steel and shipbuilding are just a few examples. The available types of construction are IM B3, IM B35 and IM V1 according to DIN EN 60034-7. The degree of protection is IP55 as standard, but IP23 for motor series 1LL8.

The 1PQ8 motors are specially designed for variable-speed applications with constant torque. The mounted separately driven fan provides a constantly high cooling air flow at any speed. These motors can therefore be continuously operated at low speed and high torque simultaneously.

The low-voltage motor series N compact is also available in a through-ventilated version to IP23 degree of protection. This 1LL8 motor series boasts an output 25 % higher than that of the closed 1LA8 motor series for the same frame size.

The 1LL8 motor is therefore useful for applications in which a closed 1LA8 motor is not essential and when the ambient conditions permit the use of a through-ventilated machine (IC 01 cooling method, IP23 degree of protection). Motors of the 1LL8 type series are only intended for installation indoors. They must not be subjected to humid, salty or corrosive atmospheres.

Design

The basic structure of the non-standard motors is shown in the following sectional diagram.

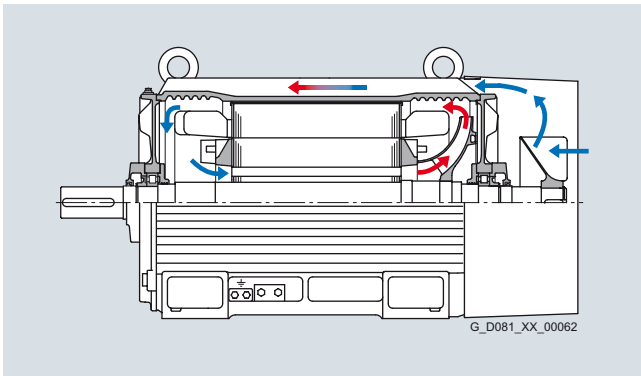

Sectional diagram of 1LA8

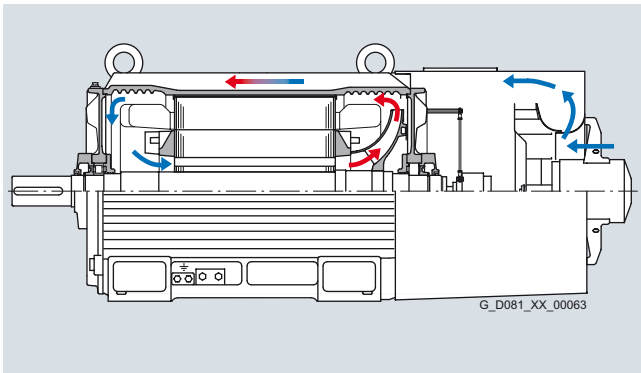

Sectional diagram of 1PQ8

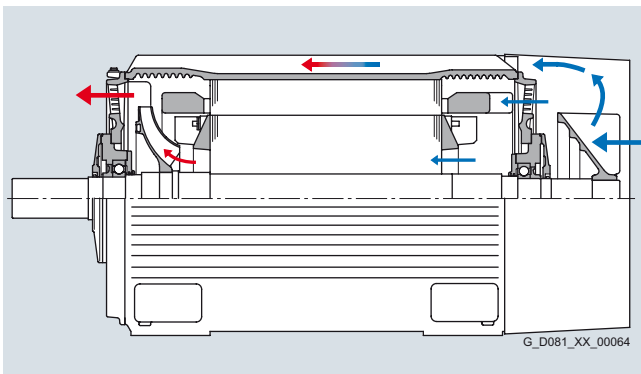

Sectional diagram of 1LL8

In conventional fin-cooled motors, the one-sided external ventilation naturally results in an uneven temperature distribution – this is however not the case with N compact motors with their additional internal air-flow channels. This cools, in particular, the stator winding heads, the rotor winding and the drive-end bearings. The resulting reduction in thermal loading increases the operating reliability and lengthens the service life. The internal air-flow channels increase the efficiency of the ventilation which means that the external air-flow can be reduced. The lower volumetric flow and air-flow optimisation of all guide channels results in a low level of fan noise.

3

IEC Squirrel-Cage Motors

Non-standard motors frame size 315 and above

Orientation

Technical specifications

The following table lists the most important technical specifications. For further information and details, see catalog part 0 "Introduction".

Technical specifications at a glance

Type of motor	Squirrel-cage induction motor
Connection types	Star/delta connection You can establish the connection type used from the Order No. supplements in the selection and ordering data for the required motor.
Number of poles	2, 4, 6, 8
Rated output	160 ... 1250 kW (at 50 Hz)
Rated speed (synchronous speed)	750 ... 3600 rpm
Rated torques	800 ... 10,300 Nm
Insulation of the stator winding according to EN 60034-1 (IEC 60034-1)	Temperature class 155 (F) Used in mains-fed operation (at rated output) as: temperature class 130 (B) Used in converter-fed operation (at rated output): temperature class 155 (F) For coolant temperatures of up to 40 °C as standard DURIGNIT IR 2000 insulation system with impregnation by VPI or current-UV technique
Degree of protection according to EN 60034-5 (IEC 60034-5)	Motor series 1LA8 and 1PQ8: IP55 Motor series 1LL8: IP23
Cooling according to EN 60034-6 (IEC 60034-6)	Self-ventilated (motor series 1LA8) Motor frame sizes 315 to 450 (IC 411) Forced-air cooled (motor series 1PQ8) Motor frame sizes 315 to 450 (IC 416) Self-ventilated (motor series 1LL8) Motor frame sizes 315 to 450 (IC 01)
Admissible coolant temperature	See "Coolant temperature and site altitude" in catalog part 0 "Introduction"
Standard voltages according to EN 60038 (IEC 60038)	50 Hz: 400 V, 500 V, 690 V The voltage used can be found in the selection and ordering data for the required motor.
Type of construction according to EN 60034-7 (IEC 60034-7)	<u>Without flange:</u> IM B3 <u>With flange:</u> IM V1 without protective cover, IM V1 with protective cover, IM B35
Frame design	Cast-iron with cast frame feet for IM B3 and IM B35 types of construction
Paint finish Suitability of paint finish for climate group in accordance with IEC 60721, Part 2-1	<u>Standard:</u> Standard paint finish (moderate = expanded) RAL 7030 stone gray
Vibration quantity level according to EN 60034-14 (IEC 60034-14)	Level A (standard- without special vibration requirements) optional: Level B (with special vibration requirements)
Shaft extension according to DIN 748 (IEC 60072)	With featherkey, half-key balancing
Shaft and flange accuracy according to DIN 42955 (IEC 60072-1)	Tolerance N (normal) <u>Optional:</u> Tolerance R (reduced)
Sound pressure level to DIN EN ISO 1680 (tolerance +3 dB)	The sound pressure level is listed in the selection and ordering data for the required motor.
Weights	The weight is listed in the selection and ordering data for the required motor.
Mechanical limit speeds	The limit speed is listed in the selection and ordering data for the required motor.
Packing weights and dimensions	See "Packing weights and packing dimensions" in catalog part 0 "Introduction".
Rating plates	Fixed to the motor (optionally: 1 additional set of rating plates, loose), labeled as standard in English/German, can be supplied in French/Spanish, Italian or Portuguese without additional charge See "Rating plate" in catalog part 0 "Introduction".
Connection and connection boxes	See "Connection, circuit and connection box" in catalog part 0 "Introduction".
Bearing design	See "Bearings" in catalog part 0 "Introduction".
Cantilever forces	See "Admissible cantilever forces" in catalog part 0 "Introduction"
Pulse encoder	See "Special technology" in catalog part 0 "Introduction"
Options	See the selection and ordering data for "Special versions"

IEC Squirrel-Cage Motors

Non-standard motors frame size 315 and above

Orientation

Technical specifications (continued)

Rating plate

According to DIN EN 60034-1, the approximate overall weight is specified on the rating plate for all motors of frame size 90 and above (from approx. 30 kg).

For all motors, an additional rating plate can be supplied loose, order code **K31**. An extra rating plate for identification codes is also possible, order code **Y82**. In the standard version, the rating plate is available in English and German.

SIEMENS										
15	3-MOT. 1LA8 317-4AB60-Z NoN- R41124661010001/2003 IMB3 Th.CI.155(F)									
1	V	Hz	A	kW	cosφ	1/min	I _A /I _N	T _E s	Certif.No	IP
4	400 Δ	50	540	315	0.87	1488				55
12	690 Y		315							
7	Rotor SQU.CAGE KL 13 EN/IEC 60034-1 Gew/Wt 1.5 t									
5	380..420VΔ, 560..530A 660..725V Y, 325..305A 50Hz									
16	N _{MAX} =3000 1/MIN									
17	S.F. 1.10									
18	MADE IN GERMANY D-90441 Nürnberg									

1 Motor type: 3-phase LV motor	9 Motor weight [kg]
2 Type of construction	10 Temperature class
3 Degree of protection	11 Rated speed [rpm]
4 Rated voltage [V] and circuit	12 Rated frequency [Hz]
5 Rated current [A]	13 Power factor [cos φ]
6 Rated output [kW]	14 Maximum speed [rpm]
7 Standards and regulations e.g. explosion-proof motors	15 Motor type
8 Serial number	16 Rotor class
	17 Additional details (optional)
	18 Service factor

Example of rating plate for 1LA8

Converter-fed operation

The motors are equipped with standard rotors and are suitable for mains-fed or converter-fed operation.

All motors can therefore be operated with a converter, in principle. Special measures are necessary in the case of some motors, especially when separately driven fans are used.

All data are applicable for a 50 Hz sinusoidal supply.

Rated voltage

The tolerance for the rated voltage is in accordance with DIN EN 60034-1 in all cases, a rated voltage range is not specified.

Motor protection

A motor protection function can be implemented using the I^2t detection present in the converter software.

If required, more precise motor protection can be afforded by direct temperature measurement using KTY84 sensors, PT 100 resistance thermometers or PTC thermistors in the motor winding. Some converters from Siemens determine the motor temperature using the resistance of the temperature sensor. They can be set to a required temperature for alarm and tripping.

If PT 100 resistance thermometers are ordered for cooling temperature monitoring (order code **A61**) or KTY84 temperature sensors (order code **A23**), the standard thermistors are omitted. A combination of **A12** and **A61** or **A12** and **A23** is possible; additional charge on request.

Insulation

The standard insulation of the motors is designed such that converter-fed operation is possible without limitation at voltages ≤ 500 V. This also applies for operation with a pulse-controlled AC converter with voltage rise times $t_s > 0.1 \mu\text{s}$ at the motor terminals.

All motors with voltage codes 4, 5 and 8 must be operated under these preconditions on a converter.

This does not apply to motors with voltages > 500 up to 690 V, which must have special insulation for operation on a pulse-controlled AC converter (SINAMICS, SIMOVERT MASTERDRIVES) without a converter circuit (du/dt filter or sinusoidal filter), i.e. when 10th position of the Order No. = "M".

For converter-fed operation with the outputs specified in the catalog, the motors are used according to temperature class 155 (F), i.e. in this case neither a service factor > 1 nor an increased coolant temperature is possible (order codes C11, C12 and C13 cannot be ordered).

Motor connection

When connecting the motors, it is important to consider the restrictions for mains-fed machines as well as the maximum conductor cross-sections permitted for the converter.

Ventilation/noise generation

The fan noise can increase at speeds that are higher than the rated speed of self-ventilated motors (this is not the case for forced ventilated motors 1PQ8). To increase motor utilization at low speeds it is recommended that forced ventilated motors are used, e.g. those of series 1PQ8.

In general, for converter-fed operation, the noise level is higher than that specified in the catalog (exception: 1PQ8). The increase depends on the converter type and can lie between 5 and 10 dB(A) depending on the frame size and number of poles for the motor.

Mechanical stress and grease lifetime

When motors are operated at speeds above the rated speed, the running smoothness and the bearings are subjected to greater mechanical stress. This reduces the grease lifetime and the bearing lifetime. More detailed information on request.

Bearings

To prevent damage being caused as a result of bearing currents, insulated bearings are used at the non-drive-end of 1LA8, 1LL8 and 1PQ8 motors for converter-fed operation in the standard version (this can be recognized when 9th position of Order No. = "P").

When operating multiphase induction machines on a converter, an electrical bearing stress results from a capacitive induced voltage via the bearing lubricating film, depending on the principle being used. The physical cause of this is the common-mode voltage at the converter output that is inherent in the control method for a converter: the sum of the three-phase voltages is – in contrast to straightforward mains-fed operation – not equal to zero at every point in time. The high-frequency, pulse-shaped common-mode voltage brings about a residual current, which closes back to the converter's DC link via the machine's internal capacitances, the machine housing and the earthing circuit. The machine's internal capacitances include the main insulation winding capacitance, the geometric capacitance between the rotor and stator, the lubricating film capacitance and the capacitance of any bearing insulation that may be present. The level of the currents due to the internal capacitances is proportional to the gradients, i.e. the voltage variation of the DC voltage ($i_{(t)} = C \cdot du/dt$).

IEC Squirrel-Cage Motors

Non-standard motors frame size 315 and above

Orientation

Technical specifications (continued)

In order to apply currents to the motor which are sinusoidal as far as possible (smooth running, oscillation torques, stray losses), a high clock frequency is required for the converter's output voltage. The related (very steep) switching edges of the converter output voltage (and also, therefore, of the common-mode voltage) cause correspondingly high capacitive currents and voltages on the machine's internal capacitances.

The voltage that is injected capacitively across the bearing can result, in the worst case, in stochastic arcing through the lubrication film of the bearing and prematurely age or damage the bearing. (The current pulses caused by arcing in the lubrication film are known as EDM currents (Electrostatic Discharge Machining) in the technical literature.)

This physical effect, which occurs in isolated cases, has mostly been observed in connection with larger motors.

EMC-compliant installation of the drive system is a basic prerequisite for preventing premature bearing damage as a result of bearing currents.

The most important measures for reducing bearing currents:

- Insulated motor bearings at the non-drive-end NDE (BS) (standard for 1LA8, 1LL8 and 1PQ8 for converter-fed operation)
- Use of cables with a symmetrical cable cross-section:

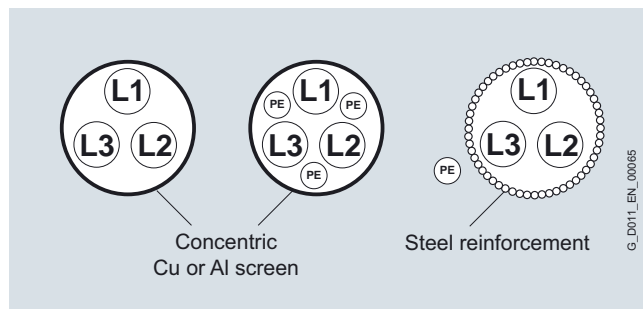

- Preference given to a supply with insulated neutral point (IT system)
- Use of earthing cables with low impedance in a large frequency range (DC up to approximately 70 MHz): for example, plaited copper ribbon cables, HF litz wires
- Separate HF equipotential-bonding cable between motor frame and driven machine
- Separate HF equipotential-bonding cable between motor housing and converter PE busbar
- 360° HF contacting of the cable shield on the motor frame and the converter PE busbar. This can be achieved using EMC screwed glands on the motor end and EMC shield clips on the converter end, for example.
- Using motor reactors at the converter
- Common-mode filters at the converter output

Thermal torque limits

Guide values for the maximum load torques at various speeds can be obtained from the diagrams below.

In the case of self-ventilated motors, such as series 1LA8 and 1LL8, the thermally permissible load torques are reduced for continuous operation for speeds below the rated speed. This must be taken into account in those applications in particular that are not subjected to a load torque that is dependent on the square of the speed. Also in the case of forced-air cooled motors of series 1PQ8, the maximum load torques are reduced slightly for high speed ranges.

When motors are operated at speeds above their rated speed (operation in the field-weakening range), the maximum load torque is also reduced.

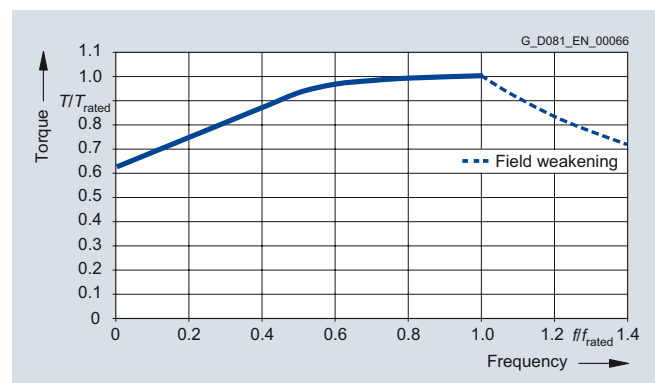

Thermal torque limit characteristic 1LA8

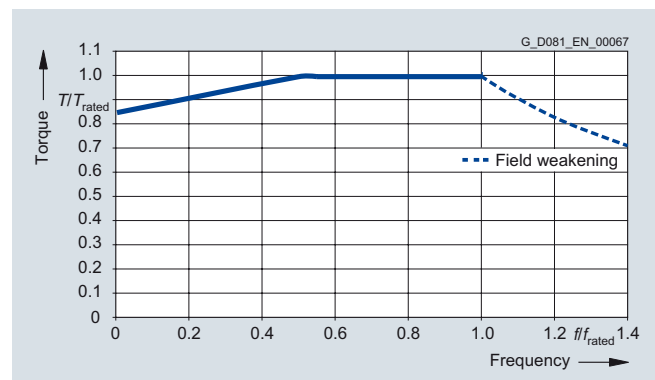

Thermal torque limit characteristic 1PQ8

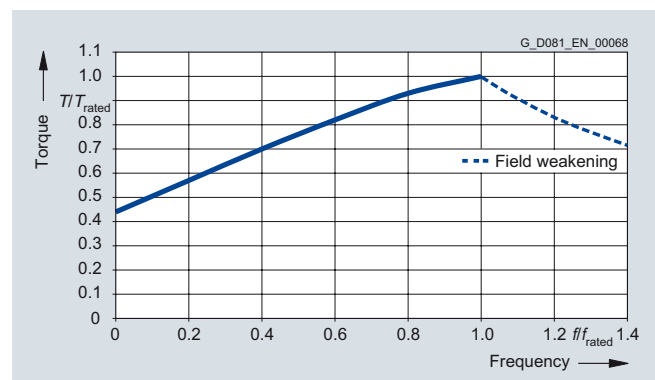

Thermal torque limit characteristic 1LL8

IEC Squirrel-Cage Motors

Non-standard motors frame size 315 and above

Orientation

Technical specifications (continued)

Technical explanations regarding torque and determination of the start-up time for mains-fed operation

Torque characteristics – Torque characteristics for special drives

Torque characteristics

The torque generated on the shaft of a three-phase motor in the torque range of $n = 0$ to $n = n_s$ has a very varying magnitude. The characteristic curve of the torque as a function of the speed of a three-phase motor with torque class (CL) of a squirrel-cage rotor shows the following diagram.

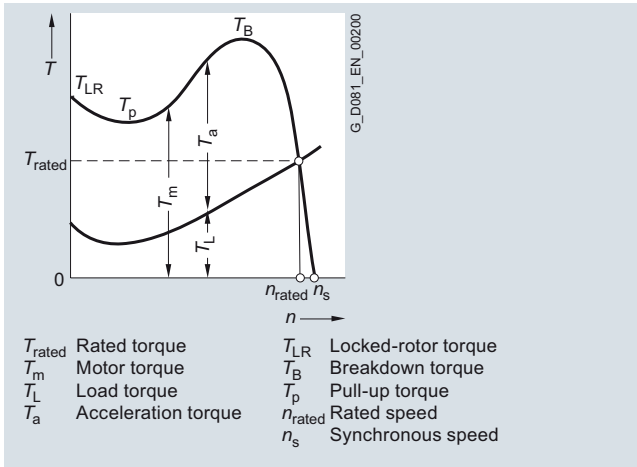

The values for locked-rotor torque and breakdown torque as well as for locked-rotor current of a specific motor can be taken from the selection and ordering data.

The limit for the mechanical overload capability is the breakdown torque. According to IEC/EN 60034-1, asynchronous motors at rated voltage and rated frequency must withstand up to 1.6 times the rated torque for 15 s. The pull-up torque of asynchronous motors at rated voltage must - if not specified otherwise - have at least the values stated in the following rated torque.

For three-phase motors without pole-change with a rated output equal to or greater than 100 kW:

0.3 times rated torque and at least 0.5 times locked-rotor torque

According to IEC/EN 60034-1, the following tolerances are permitted:

- for the locked-rotor torque of -15 to 25 % of the total locked-rotor torque
- for the locked-rotor current up to 20 % of the stated locked-rotor current without lower limit
- for the breakdown torque up to -10 % of the stated breakdown torque
- for the pull-up torque -15 % of the guaranteed value.

Under observance of these tolerances, the locked-rotor torque must be sufficiently higher than the break loose torque of the driven machine and the motor torque during start-up up to reaching the operating speed must always be higher than the load torque.

In the case of squirrel-cage motors, the locked-rotor torque and breakdown torque are listed in the selection and ordering data as multiples of the rated torque. The normal practice is to start squirrel-cage motors directly online. The torque class indicates that with direct online starting, even if there is a 5 % undervoltage, it is possible to start up the motor against a load torque of:

- 130 % (for CL 13),
- 100 % (for CL 10),
- 70 % (for CL 7),
- 50 % (for CL 5)

of the rated torque.

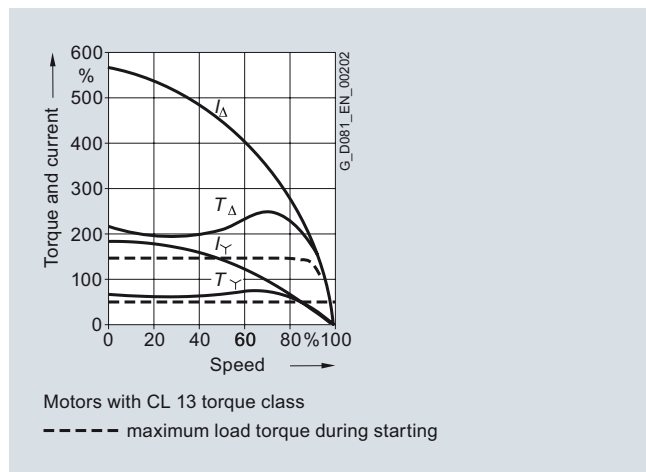
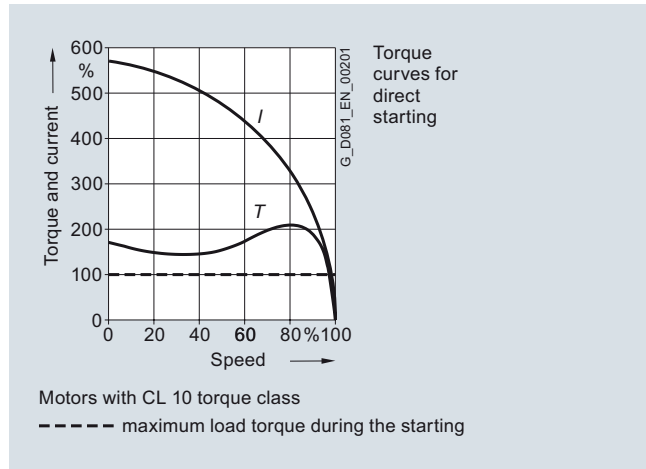

The rated torque can be calculated as follows:

$$T_{rated} = 9.55 \cdot P_{rated} \cdot \frac{1000}{n_{rated}}$$

T_{rated} Rated torque in Nm
 n_{rated} Rated speed in rpm
 P_{rated} Rated output in kW

The rated speed of the motor differentiates itself from the synchronous speed by the slip s_{rated} :

It is:

$$s_{rated} = \frac{n_s - n_{rated}}{n_s} \cdot 100$$

s_{rated} Slip in %
 n_s Synchronous speed in rpm
 n_{rated} Rated speed in rpm

Determination of the start-up time

Calculation of the start-up time for direct online starting

The start-up time from $n = 0$ to $n = n_{op}$ can be approximately determined using the average acceleration torque.

$$t_{st} = \frac{\sum J \cdot n_{op}}{9.55 \cdot T_{aav}}$$

t_{st} Start-up time in s
 J Total moment of inertia in kgm^2
 n_{op} Operating speed in rpm
 T_{aav} Average acceleration torque in Nm

IEC Squirrel-Cage Motors

Non-standard motors frame size 315 and above

Orientation

Technical specifications (continued)

The total moment of inertia is made up of the motor moment of inertia plus the moment of inertia of the driven machine and the coupling or pulleys and is converted to the speed of the motor shaft.

Limit values for the start-up curve of three-phase motors with squirrel-cage rotor for voltages up to and including 690 V are defined in EC/EN 60034.

If no sound start-up is possible due to a high moment of inertia and/or a high load torque, a larger motor or a three-phase motor with SINAMICS frequency converter can be selected for N-compact motors.

A mechanical solution for coping with the heavy starting is the employment of a starting coupling, whose application is limited by its capability to absorb heat.

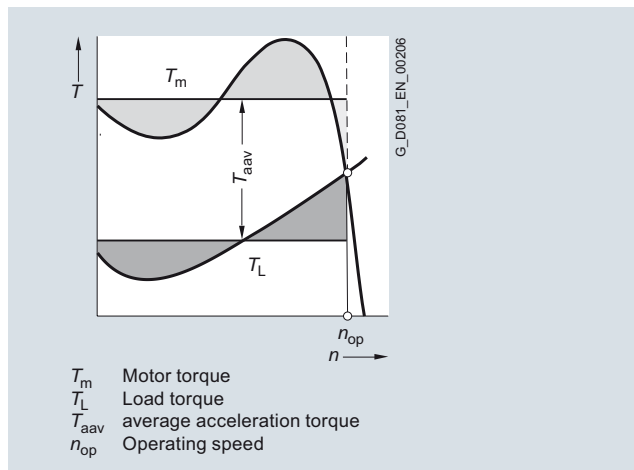

Determination of the average acceleration torque

Start-up for three-phase motors with squirrel-cage rotor

The normal practice is to start squirrel-cage motors directly on-line.

- It must be observed that the torque and speed characteristics for a specific motor are predetermined - independently of the heaviness of the start-up. Star delta start-up must be realized for motors with squirrel-cage rotor if small locked-rotor currents (e.g. in the supply conditions of the electric power company) or a particularly low start-up torque (soft starting) are required. Locked-rotor torque, breakdown torque and all other torque values as well as the locked-rotor current are 25 to 30 % of the values at direct online starting.

- The motor torque must be sufficiently higher than the load torque during the start-up in the Y-stage. The change from star to delta must not occur before approximating the operating speed.

The adjoining diagram shows a case in which the star delta start-up is not appropriate because the too elevated load torque causes the early change which in turn causes a high torque and current surge that renders the star-delta starting ineffective.

The torque characteristics can be approximately reduced by the square of the voltage and the current characteristics linearly with the voltage by reducing the voltage at the motor terminals with the help of a starting transformer or starting resistors.

A starting with rated current is possible on the converter.

Soft starting for motors with squirrel-cage rotor can also be realized using the stator-resistance starting circuit (a resistor is engaged in one phase during the start-up). The locked-rotor torque can be arbitrarily reduced with the help of this circuit. The locked-rotor current without a resistor or reactor is a bit higher in both phases than for direct online starting.

The starting can be facilitated using the electrical motor starter "SIKOSTART", that limits the torque and the current during starting.

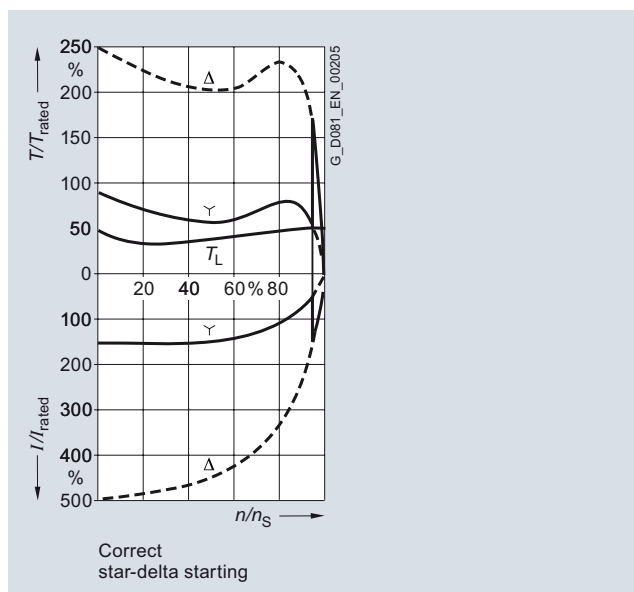
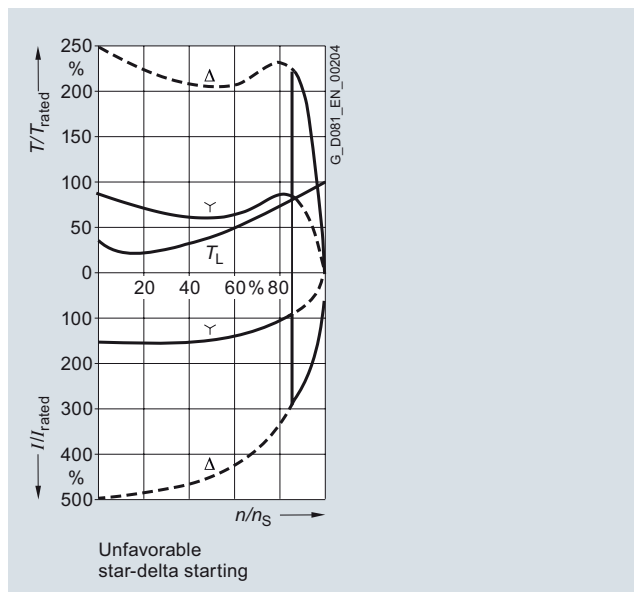

IEC Squirrel-Cage Motors

Non-standard motors frame size 315 and above

Orientation

Technical specifications (continued)

The following has to be provided in case of requests regarding start-ups:

- 1st Required output and rated speed of the driven machine
- 2nd Planned motor speed
- 3rd Load torque of the driven machine, depending on the speed of the driven machine or the motor speed
- 4th Total external moments of inertia and rated speed of the driven machine or with regard to the motor speed
- 5th Number of starts within a particular time frame and duty cycle or
- 6th Characteristics and number of operating cycles within a particular time frame (method of braking)

Start-up times and moments of inertia for 1LA8 motors for mains-fed operation

Default values

The values in the following table are only valid for 1LA8 motors for mains-fed operation (Pages 3/14 to 3/17) and apply for a continuous heating of 90 % of the rated output at 50 Hz ($0.9 \times P_{\text{rated}}$). The admissible moments of inertia must be reduced again by 20 % at 60 Hz. The moment of inertia J_{adm} in the tables is the moment of inertia which the driven machine is allowed to have as a maximum in order to start the motor. For this purpose has the moment of inertia already been considered in the selection and ordering data, Pages 3/15 to 3/17.

Frame size	Order No.	Locking of brake		Admissible moment of inertia and start-up times when starting the motor			
		cold	warm	1x cold		1x warm	
		Braking time	Braking time	Moment of inertia	Start-up time	Moment of inertia	Start-up time
FS		t_{Br} s	t_{Br} s	J_{adm} kgm ²	t_{st} s	J_{adm} kgm ²	t_{st} s
Self-ventilated motors for mains-fed operation cast-iron series 1LA8 – 2-pole, 3000 rpm at 50 Hz							
315	1LA8 315-2AC□□	18	10	125	33.9	48	13.0
315	1LA8 317-2AC□□	17.5	10	140	33.2	58	13.4
355	1LA8 353-2AC□□	18	9	175	41.4	33	7.8
355	1LA8 355-2AC□□	20	10	190	45.8	40	9.7
355	1LA8 357-2AC□□	15	7.5	180	30.0	40	6.7
400	1LA8 403-2AC□□	22	13	245	40.2	95	15.7
400	1LA8 405-2AC□□	19	11	255	37.2	90	13.1
400	1LA8 407-2AC□□	17	9.5	300	34.9	85	9.9
450	1LA8 453-2AE□□	21.5	15	178	31.3	83	14.6
450	1LA8 455-2AE□□	20.5	14	190	30.2	90	14.3
450	1LA8 457-2AE□□	19	13	200	28.2	95	13.4
Self-ventilated motors for mains-fed operation cast-iron series 1LA8 – 4-pole, 1500 rpm at 50 Hz							
315	1LA8 315-4AB□□	22	13	590	36.9	350	21.9
315	1LA8 317-4AB□□	19	11	730	32.3	425	18.8
355	1LA8 353-4AB□□	20	11	1000	45.7	270	12.4
355	1LA8 355-4AB□□	18	10	1020	39.6	280	10.9
355	1LA8 357-4AB□□	19	10.5	1370	41.9	370	11.3
400	1LA8 403-4AB□□	20.5	11.5	1420	46.2	430	14.0
400	1LA8 405-4AB□□	20	11	1600	44.5	480	13.3
400	1LA8 407-4AB□□	19	10.5	1750	43.6	525	13.1
450	1LA8 453-4CE□□	17.5	10	950	23.7	300	7.5
450	1LA8 455-4AC□□	18.5	10.5	1200	26.8	370	8.3
450	1LA8 457-4AC□□	17	9	1160	22.3	380	7.3

IEC Squirrel-Cage Motors

Non-standard motors frame size 315 and above

Orientation

Technical specifications (continued)

Frame size	Order No.	Locking of brake		Admissible moment of inertia and start-up times when starting the motor			
		cold	warm	1x cold		1x warm	
		Braking time	Braking time	Moment of inertia	Start-up time	Moment of inertia	Start-up time
FS		t_{Br} s	t_{Br} s	J_{adm} kgm ²	t_{st} s	J_{adm} kgm ²	t_{st} s
Self-ventilated motors for mains-fed operation cast-iron series 1LA8 – 6-pole, 1000 rpm at 50 Hz							
315	1LA8 315-6ABQQ	33	18	1900	57.4	830	25.1
315	1LA8 317-6ABQQ	31	15.5	2300	55.6	1000	24.2
355	1LA8 355-6ABQQ	40	22	2950	62.2	1350	28.5
355	1LA8 357-6ABQQ	40	22	3950	62.5	1800	28.5
400	1LA8 403-6ABQQ	34	18.4	3450	51.1	850	12.6
400	1LA8 405-6ABQQ	32	17.5	3500	43.3	900	11.1
400	1LA8 407-6ABQQ	24	12	2200	25.6	740	8.6
450	1LA8 453-6ABQQ	16	7	1400	15.5	560	6.2
450	1LA8 455-6ABQQ	19	8.5	1700	18.1	670	7.1
450	1LA8 457-6ABQQ	16	7	1800	15.9	720	6.4
Self-ventilated motors for mains-fed operation cast-iron series 1LA8 – 8-pole, 750 rpm at 50 Hz							
315	1LA8 315-8ABQQ	40	22	4800	109.5	1950	44.5
315	1LA8 317-8ABQQ	42	23	6800	125.9	2500	46.3
355	1LA8 355-8ABQQ	41	22.5	6200	89.6	3100	44.8
355	1LA8 357-8ABQQ	40	22	7600	88.7	3800	44.3
400	1LA8 403-8ABQQ	55	30	9700	107.5	4400	48.8
400	1LA8 405-8ABQQ	54	29.5	11000	102.9	5400	50.5
400	1LA8 407-8ABQQ	52	28.5	11200	95.4	5400	46.0
450	1LA8 453-8ABQQ	44	25	9800	78.8	2900	23.3
450	1LA8 455-8ABQQ	42	23	10500	71.4	3000	20.4
450	1LA8 457-8ABQQ	44	25	12400	78.1	3700	23.3

IEC Squirrel-Cage Motors

Non-standard motors frame size 315 and above

Orientation

Selection and ordering data

Preliminary selection of the motor according to motor type/series, speed or number of poles, frame size, rated output, rated torque, rated speed and rated current

Self-ventilated motors for mains-fed operation (IP55 degree of protection)

Speed	Frame size	Rated output	Rated speed	Rated torque	Rated current at 400 V	Detailed selection and ordering data Page
rpm		kW	rpm	Nm	A	
Cast-iron series 1LA8						
3000, 2-pole	315 ... 450	250 ... 1000	2979 ... 2986	801 ... 3200	415 ... 1020	3/14 ... 3/15
1500, 4-pole	315 ... 450	250 ... 1000	1488 ... 1492	1600 ... 6400	430 ... 1060	3/14 ... 3/15
1000, 6-pole	315 ... 450	200 ... 800	988 ... 993	1930 ... 7690	345 ... 1100	3/16 ... 3/17
750, 8-pole	315 ... 450	160 ... 630	739 ... 744	2070 ... 8090	295 ... 1160	3/16 ... 3/17

Self-ventilated motors for converter-fed operation (IP55 degree of protection)

Speed	Frame size	Rated output	Rated speed	Rated torque	Rated current at 400 V	Detailed selection and ordering data Page
rpm		kW	rpm	Nm	A	
Cast-iron series 1LA8 with standard insulation ≤500 V						
3000, 2-pole	315 ... 450	250 ... 1000	2979 ... 2986	801 ... 3200	415 ... 1020	3/18 ... 3/19
1500, 4-pole	315 ... 450	250 ... 1000	1488 ... 1492	1600 ... 6400	430 ... 1060	3/18 ... 3/19
1000, 6-pole	315 ... 450	200 ... 800	988 ... 993	1930 ... 7690	345 ... 1100	3/20 ... 3/21
750, 8-pole	315 ... 450	160 ... 630	739 ... 744	2070 ... 8090	295 ... 1160	3/20 ... 3/21

Speed	Frame size	Rated output	Rated speed	Rated torque	Rated current at 690 V	Detailed selection and ordering data Page
rpm		kW	rpm	Nm	A	
Cast-iron series 1LA8 with special insulation >500 to 690 V						
3000, 2-pole	315 ... 450	240 ... 970	2978 ... 2987	770 ... 3101	730 ... 900	3/22 ... 3/23
1500, 4-pole	315 ... 450	235 ... 980	1485 ... 1492	1511 ... 6273	235 ... 950	3/22 ... 3/23
1000, 6-pole	315 ... 450	190 ... 780	990 ... 993	1833 ... 7502	196 ... 790	3/24 ... 3/25
750, 8-pole	315 ... 450	145 ... 600	740 ... 745	1871 ... 7691	162 ... 660	3/24 ... 3/25

Forced-air cooled motors with mounted separately driven fan for converter-fed operation (IP55 degree of protection)

Speed	Frame size	Rated output	Rated speed	Rated torque	Rated current at 400 V	Detailed selection and ordering data Page
rpm		kW	rpm	Nm	A	
Cast-iron series 1PQ8 with standard insulation ≤500 V						
3000, 2-pole	315 ... 450	250 ... 1000	2979 ... 2986	801 ... 3200	415 ... 1020	3/26 ... 3/27
1500, 4-pole	315 ... 450	250 ... 1000	1488 ... 1492	1600 ... 6400	430 ... 1060	3/26 ... 3/27
1000, 6-pole	315 ... 450	200 ... 800	988 ... 993	1930 ... 7690	345 ... 1100	3/28 ... 3/29
750, 8-pole	315 ... 450	160 ... 630	739 ... 744	2070 ... 8090	295 ... 1160	3/28 ... 3/29

Speed	Frame size	Rated output	Rated speed	Rated torque	Rated current at 690 V	Detailed selection and ordering data Page
rpm		kW	rpm	Nm	A	
Cast-iron series 1PQ8 with special insulation >500 to 690 V						
3000, 2-pole	315 ... 450	240 ... 970	2978 ... 2987	770 ... 3101	730 ... 900	3/30 ... 3/31
1500, 4-pole	315 ... 450	235 ... 980	1485 ... 1492	1511 ... 6273	235 ... 950	3/30 ... 3/31
1000, 6-pole	315 ... 450	190 ... 780	990 ... 993	1833 ... 7502	196 ... 790	3/32 ... 3/33
750, 8-pole	315 ... 450	145 ... 600	740 ... 745	1871 ... 7691	162 ... 660	3/32 ... 3/33

IEC Squirrel-Cage Motors

Non-standard motors frame size 315 and above

Orientation

Selection and ordering data (continued)

Self-ventilated motors with through-ventilation for mains-fed operation (IP23 degree of protection)

Speed	Frame size	Rated output	Rated speed	Rated torque	Rated current at 400 V	Detailed selection and ordering data Page
rpm		kW	rpm	Nm	A	
Cast-iron series 1LL8						
3000, 2-pole	315 ... 450	315 ... 1250	2974 ... 2986	1010 ... 4000	510 ... 1300	3/34 ... 3/35
1500, 4-pole	315 ... 450	315 ... 1250	1483 ... 1490	2030 ... 8010	540 ... 1360	3/34 ... 3/35
1000, 6-pole	315 ... 450	250 ... 1000	988 ... 993	2420 ... 9620	430 ... 1380	3/36 ... 3/37
750, 8-pole	315 ... 450	200 ... 800	738 ... 743	2590 ... 10300	370 ... 1440	3/36 ... 3/37

Self-ventilated motors with through-ventilation for converter-fed operation (IP23 degree of protection)

Speed	Frame size	Rated output	Rated speed	Rated torque	Rated current at 400 V	Detailed selection and ordering data Page
rpm		kW	rpm	Nm	A	
Cast-iron series 1LL8 with standard insulation ≤500 V						
3000, 2-pole	315 ... 450	315 ... 1250	2974 ... 2986	1010 ... 4000	510 ... 1300	3/38 ... 3/39
1500, 4-pole	315 ... 450	315 ... 1250	1483 ... 1490	2030 ... 8010	540 ... 1360	3/38 ... 3/39
1000, 6-pole	315 ... 450	250 ... 1000	988 ... 993	2420 ... 9620	430 ... 1380	3/40 ... 3/41
750, 8-pole	315 ... 450	200 ... 800	738 ... 743	2590 ... 10300	370 ... 1440	3/40 ... 3/41

Speed	Frame size	Rated output	Rated speed	Rated torque	Rated current at 690 V	Detailed selection and ordering data Page
rpm		kW	rpm	Nm	A	
Cast-iron series 1LL8 with special insulation >500 to 690 V						
3000, 2-pole	315 ... 450	300 ... 1210	2977 ... 2988	962 ... 3871	290 ... 800	3/42 ... 3/43
1500, 4-pole	315 ... 450	295 ... 1225	1485 ... 1493	1897 ... 7846	300 ... 880	3/42 ... 3/43
1000, 6-pole	315 ... 450	235 ... 975	990 ... 994	2267 ... 9377	240 ... 850	3/44 ... 3/45
750, 8-pole	315 ... 450	180 ... 760	738 ... 742	2329 ... 9782	198 ... 800	3/44 ... 3/45

IEC Squirrel-Cage Motors

Non-standard motors frame size 315 and above

Orientation

More information

Standardline

4-pole 1LA8 motors are available with a reduced range of options up to an output of 500 kW in the *Standardline*.

The benefit to the customer:

- Much shorter delivery time
- Products in the *Standardline* can be configured with a variety of options so as to ensure a high degree of flexibility.

Application:

Standardline low-voltage motors are optimised for applications in pump, fan and compressor drives.

For the low-voltage motors, this is particularly true for complete, coordinated drive systems comprising the motor and a SINAMICS G150 frequency converter.

Standardline motors can be ordered with the order code **B20**.

Scope of the *Standardline*:

- 4-pole version
- Power range 250 to 500 kW
- Types 1LA8 315, 1LA8 317, 1LA8 353, 1LA8 355 and 1LA8 357
- Type of construction code **0** (IM B3)
- For mains-fed operation: Voltage code **6** (400 V Δ /690 VY) or **5** (500 V Δ)
- For converter-fed operation: Voltage code **4** (400 V Δ), **8** (400 V Δ /690 VY) or **5** (500 V Δ)
- Can be ordered for converter-fed operation, but not in the 690 V version
- Possible order codes: **A23, A61, A72, G50, H70, H73, K09, K10, K45, K46, K57, K83, K84, K85, L00, L97, M58** (only frame size 315), **M88** and **Y53**

For more information, see Catalog D 86.1 *Standardline*.

For more information, please contact your local Siemens contact – see “Siemens contacts worldwide” in the Appendix.

IEC Squirrel-Cage Motors

Non-standard motors frame size 315 and above

Self-ventilated motors for mains-fed operation
Cast-iron series 1LA8

Selection and ordering data

Rated output at		Frame size	Operating values at rated output							Order No.	Price	Weight of IM B3 type of construction, approx.
50 Hz	60 Hz		Rated speed at 50 Hz	Rated torque at 50 Hz	Efficiency at 50 Hz 4/4-load	Efficiency at 50 Hz 3/4-load	Power factor at 50 Hz 4/4-load	Rated current at 50 Hz 400 V	Rated current at 50 Hz 690 V			
P_{rated} kW	P_{rated} kW	FS	n_{rated} rpm	T_{rated} Nm	η_{rated} %	η_{rated} %	$\cos\phi_{\text{rated}}$	I_{rated} A	I_{rated} A	For Order No. supplements for voltage and type of construction, see table below	m kg	
2-pole, 3000 rpm at 50 Hz, 3600 rpm at 60 Hz, temperature class 155 (F), used acc. to temperature class 130 (B), IP55 degree of protection												
250	280	315	2979	801	96.2	96.2	0.90	415	240	1LA8 315-2AC□□	1300	
315	353	315	2979	1010	96.5	96.5	0.91	520	300	1LA8 317-2AC□□	1500	
355	398	355	2980	1140	96.5	96.5	0.90	590	340	1LA8 353-2AC□□	1900	
400	448	355	2980	1280	96.7	96.7	0.91	660	380	1LA8 355-2AC□□	2000	
500	560	355	2982	1600	97.1	97.1	0.91	820	475	1LA8 357-2AC□□	2200	
560	616	400	2985	1790	97.1	97.1	0.91	910	530	1LA8 403-2AC□□	2800	
630	693	400	2985	2020	97.1	97.1	0.91	1020	600	1LA8 405-2AC□□	3000	
710	781	400	2985	2270	97.3	97.3	0.91	–	670 ¹⁾	1LA8 407-2AC□□	3200	
800	–	450	2986	2560	97.2	97.2	0.91	–	760	1LA8 453-2AE□□	4000	
900	–	450	2986	2880	97.3	97.3	0.92	–	840	1LA8 455-2AE□□	4200	
1000	–	450	2986	3200	97.4	97.4	0.93	–	920	1LA8 457-2AE□□	4400	
4-pole, 1500 rpm at 50 Hz, 1800 rpm at 60 Hz, temperature class 155 (F), used acc. to temperature class 130 (B), IP55 degree of protection												
250	288	315	1488	1600	96.0	96.0	0.87	430	250 ²⁾	1LA8 315-4AB□□	1300	
315	362	315	1488	2020	96.2	96.2	0.87	540	315 ²⁾	1LA8 317-4AB□□	1500	
355	408	355	1488	2280	96.3	96.3	0.87	610	355 ²⁾	1LA8 353-4AB□□	1900	
400	460	355	1488	2570	96.4	96.4	0.87	690	400 ²⁾	1LA8 355-4AB□□	2000	
500	575	355	1488	3210	96.7	96.7	0.88	850	490 ²⁾	1LA8 357-4AB□□	2200	
560	644	400	1492	3580	96.7	96.7	0.88	950	550	1LA8 403-4AB□□	2800	
630	725	400	1492	4030	96.9	96.9	0.88	1060	620	1LA8 405-4AB□□	3000	
710	817	400	1492	4540	97.0	97.0	0.89	–	690 ¹⁾	1LA8 407-4AB□□	3200	
800	920	450	1492	5120	97.0	97.0	0.88	–	780 ¹⁾	1LA8 453-4AC□□	4000	
900	1040	450	1492	5760	97.1	97.1	0.88	–	880	1LA8 455-4AC□□	4200	
1000	1150	450	1492	6400	97.1	97.1	0.89	–	970	1LA8 457-4AC□□	4400	

Up to frame size 355, a service factor of 1.1 is stamped, above this 1.05.

Order No. supplements

Motor type	Penultimate position: Voltage code				Final position: Type of construction code			
	400 VΔ/690 VY	500 VΔ	690 VΔ	60 Hz 460 VΔ (for rated output at 60 Hz, see above)	Without flange IM B3	With flange IM V1 without protective cover ³⁾	IM V1 with protective cover ⁴⁾	IM B35
	6	5	0	9 L2F	0	8	4	6
1LA8 315-... □□ to 1LA8 405-... □□	□	○	– ⁵⁾	○	□	✓ ⁶⁾	✓ ⁶⁾	✓
1LA8 407-... □□ to 1LA8 457-... □□	–	○	□	O. R.	□	✓ ⁶⁾	✓ ⁶⁾	✓ ⁷⁾

- Standard version
- Without additional charge
- ✓ With additional charge
- O. R. Possible on request
- Not possible

Order other voltages with voltage code **9** in the penultimate position and the corresponding order code (see “Special versions” in the “Selection and ordering data” under “Voltages”).

Voltages or frequencies that are not covered by the predefined options can be ordered with order code **L1Y**. In this case, the output, voltage and frequency must be specified.

¹⁾ Can also be supplied for 400 VΔ 50 Hz with voltage code “9” and order code **L1Y** (specify output, voltage and frequency).

²⁾ **Standardline** for 1LA8 motors is a standardized range in specific versions which can be ordered with the order code **B20**. The delivery time is 4 weeks. Scope of the **Standardline**: 4-pole, types **1LA8 315**, **1LA8 317**, **1LA8 353**, **1LA8 355**, type of construction code **0** (IM B3), voltage code **6** (400 VΔ/690 VY) or **5** (500 VΔ); can be ordered for converter-fed operation, but not in 690 V version; possible order codes: **A23**, **A61**, **A72**, **G50**, **H70**, **H73**, **K09**, **K10**, **K45**, **K46**, **K57**, **K83**, **K84**, **K85**, **L00**, **L97**, **M58** (for frame size 315 only), **M88**, **Y53**.

³⁾ For explosion-proof motors, the type of construction IM V1 without protective cover is not possible.

⁴⁾ The “Second shaft extension” option, order code **K16** is not possible.

⁵⁾ As special version with voltage code “9” and order code **L1Y** (specify output, voltage and frequency).

⁶⁾ For 2-pole motors 60 Hz version, not possible for 1LA8 353 to 1LA8 457.

⁷⁾ For 2-pole motors 60 Hz version, not possible for 1LA8 453 to 1LA8 457.

IEC Squirrel-Cage Motors

Non-standard motors frame size 315 and above

Self-ventilated motors for mains-fed operation
Cast-iron series 1LA8

Selection and ordering data (continued)

Order No.	Locked-rotor torque	Locked-rotor current	Breakdown torque	Torque class	Moment of inertia	Noise at rated output		Mech. limit speed ¹⁾	Parallel feeders required		
	At 50 Hz and for direct online starting as multiple of rated torque					Measuring surface sound pressure level at 50 Hz	Sound power level at 50 Hz		400 V	500 V	690 V
	T_{LR}/T_{rated}	I_{LR}/I_{rated}	T_B/T_{rated}	CL	J kgm ²	L_{pFA} dB(A)	L_{WA} dB(A)	$n_{max.}$ rpm			
2-pole, 3000 rpm at 50 Hz, 3600 rpm at 60 Hz, temperature class 155 (F), used acc. to temperature class 130 (B), IP55 degree of protection											
1LA8 315-2AC□□	1.8	7.0	2.8	10	2.7	82 (75) ²⁾	97 (90) ²⁾	3600			Yes
1LA8 317-2AC□□	1.8	7.0	2.8	10	3.3	82 (75) ²⁾	97 (90) ²⁾	3600			Yes
1LA8 353-2AC□□	1.7	6.5	2.5	10	4.8	77 ³⁾	92 ³⁾	3600/3100 ⁴⁾	Yes	Yes	
1LA8 355-2AC□□	1.7	6.5	2.5	10	5.3	77 ³⁾	92 ³⁾	3600/3100 ⁴⁾	Yes	Yes	
1LA8 357-2AC□□	1.8	6.5	2.6	10	6.4	77 ³⁾	92 ³⁾	3600/3100 ⁴⁾	Yes		
1LA8 403-2AC□□	1.6	7.0	2.8	10	8.6	79 ³⁾	94 ³⁾	3600/3100 ⁴⁾	Yes		
1LA8 405-2AC□□	1.6	7.0	2.8	10	9.6	79 ³⁾	94 ³⁾	3600/3100 ⁴⁾	Yes	Yes	
1LA8 407-2AC□□	1.7	7.0	2.8	10	11	79 ³⁾	94 ³⁾	3600/3100 ⁴⁾		Yes	
1LA8 453-2AE□□	0.9	7.0	3.0	5	19	81 ³⁾	96 ³⁾	3000		Yes	
1LA8 455-2AE□□	0.9	7.0	2.8	5	21	81 ³⁾	96 ³⁾	3000		Yes	Yes
1LA8 457-2AE□□	0.9	7.0	2.7	5	23	81 ³⁾	96 ³⁾	3000		Yes	Yes
4-pole, 1500 rpm at 50 Hz, 1800 rpm at 60 Hz, temperature class 155 (F), used acc. to temperature class 130 (B), IP55 degree of protection											
1LA8 315-4AB□□	1.9	6.5	2.8	13	3.6	73	87	3000 (2650)		Yes	
1LA8 317-4AB□□	2.0	6.8	2.8	13	4.4	73	87	3000 (2650)		Yes	
1LA8 353-4AB□□	2.1	6.5	2.6	13	6.1	75	90	2500 (2350)	Yes	Yes	
1LA8 355-4AB□□	2.1	6.5	2.6	13	6.8	75	90	2500 (2350)	Yes	Yes	
1LA8 357-4AB□□	2.1	6.5	2.4	13	8.5	75	90	2500 (2350)	Yes		
1LA8 403-4AB□□	1.9	6.5	2.7	13	13	78	93	2200 (2100)/2100 ⁴⁾	Yes		
1LA8 405-4AB□□	1.9	6.8	2.7	13	14	78	93	2200 (2100)/2100 ⁴⁾	Yes	Yes	
1LA8 407-4AB□□	1.9	6.8	2.7	13	16	78	93	2200 (2100)/2100 ⁴⁾		Yes	
1LA8 453-4AC□□	1.6	7.0	2.6	10	23	81	96	2100 (1900)/1800 ⁴⁾		Yes	
1LA8 455-4AC□□	1.6	7.0	2.6	10	26	81	96	2100 (1900)/1800 ⁴⁾	Yes	Yes	
1LA8 457-4AC□□	1.7	7.0	2.6	10	28	81	96	2100 (1900)/1800 ⁴⁾	Yes	Yes	

Values in brackets apply to the use of motors in hazardous areas.

¹⁾ Limit speeds for reinforced bearings (order code **K20**) for 4-pole motors on request.
²⁾ Low-noise version, 2-pole, in brackets. To reduce noise, 2-pole motors can be equipped with an axial fan that is only suitable for one direction of rotation. Clockwise rotation order code **K37**, counter-clockwise rotation **K38**.

³⁾ In the standard version, the motors already have an axial fan for clockwise rotation. Order code **K37** is not necessary. For counter-clockwise rotation, order code **K38** is necessary.

⁴⁾ For vertical type of construction IM V1.

IEC Squirrel-Cage Motors

Non-standard motors frame size 315 and above

Self-ventilated motors for mains-fed operation
Cast-iron series 1LA8

Selection and ordering data (continued)

Rated output at		Frame size	Operating values at rated output						Power factor at 50 Hz 4/4-load	Rated current at 50 Hz 400 V	Rated current at 50 Hz 690 V	Order No. For Order No. supplements for voltage and type of construction, see table below	Price	Weight of IM B3 type of construction, approx. m kg
50 Hz	60 Hz		Rated speed at 50 Hz	Rated torque at 50 Hz	Efficiency at 50 Hz 4/4-load	Efficiency at 50 Hz 3/4-load	Efficiency at 50 Hz 4/4-load							
P_{rated} kW	P_{rated} kW	FS	n_{rated} rpm	T_{rated} Nm	η_{rated} %	η_{rated} %	$\cos\phi_{\text{rated}}$	I_{rated} A	I_{rated} A					
6-pole, 1000 rpm at 50 Hz, 1200 rpm at 60 Hz, temperature class 155 (F), used acc. to temperature class 130 (B), IP55 degree of protection														
200	230	315	988	1930	95.7	95.8	0.86	345	200		1LA8 315-6AB□□		1300	
250	288	315	988	2410	95.9	96.0	0.86	430	250		1LA8 317-6AB□□		1500	
315	362	355	993	3040	96.2	96.2	0.86	540	315		1LA8 355-6AB□□		2000	
400	460	355	993	3850	96.5	96.5	0.86	690	400		1LA8 357-6AB□□		2200	
450	518	400	991	4330	96.5	96.5	0.86	780	455		1LA8 403-6AB□□		2800	
500	575	400	991	4810	96.5	96.5	0.86	860	500		1LA8 405-6AB□□		3000	
560	644	400	991	5390	96.7	96.7	0.86	960	560		1LA8 407-6AB□□		3200	
630	725	450	993	6060	96.8	96.8	0.86	1100	630		1LA8 453-6AB□□		4000	
710	817	450	993	6830	96.8	96.8	0.86	–	710 ¹⁾		1LA8 455-6AB□□		4200	
800	920	450	993	7690	97.0	97.1	0.86	–	790		1LA8 457-6AB□□		4500	
8-pole, 750 rpm at 50 Hz, 900 rpm at 60 Hz, temperature class 155 (F), used acc. to temperature class 130 (B), IP55 degree of protection														
160	184	315	739	2070	94.9	94.9	0.82	295	172		1LA8 315-8AB□□		1300	
200	230	315	739	2580	95.2	95.2	0.82	370	215		1LA8 317-8AB□□		1500	
250	288	355	741	3220	95.7	95.7	0.82	460	265		1LA8 355-8AB□□		2000	
315	362	355	741	4060	96.0	96.0	0.82	580	335		1LA8 357-8AB□□		2200	
355	408	400	742	4570	96.1	96.1	0.82	650	375		1LA8 403-8AB□□		2800	
400	460	400	742	5150	96.2	96.2	0.82	730	425		1LA8 405-8AB□□		3000	
450	518	400	742	5790	96.3	96.3	0.82	820	475		1LA8 407-8AB□□		3200	
500	575	450	744	6420	96.4	96.4	0.81	920	540		1LA8 453-8AB□□		4000	
560	644	450	744	7190	96.5	96.5	0.81	1040	600		1LA8 455-8AB□□		4200	
630	725	450	744	8090	96.6	96.6	0.81	1160	670		1LA8 457-8AB□□		4500	

Up to frame size 355, a service factor of 1.1 is stamped, above this 1.05.

Order No. supplements

Motor type	Penultimate position: Voltage code				Final position: Type of construction code			
	400 VΔ/690 VY	500 VΔ	690 VΔ	60 Hz 460 VΔ (for rated output at 60 Hz, see above)	Without flange IM B3	With flange IM V1 without protective cover ²⁾	IM V1 with protective cover ³⁾	IM B35
	6	5	0	9 L2F	0	8	4	6
6-pole								
1LA8 315-...□□ to 1LA8 453-...□□	□	○	– ⁴⁾	○	□	✓	✓	✓
1LA8 455-...□□ to 1LA8 457-...□□	–	○	□	O. R.	□	✓	✓	✓
8-pole								
1LA8 315-...□□ to 1LA8 457-...□□	□	○	– ⁴⁾	○	□	✓	✓	✓

- Standard version
- Without additional charge
- ✓ With additional charge
- O. R. Possible on request
- Not possible

Order other voltages with voltage code **9** in the penultimate position and the corresponding order code (see "Special versions" in the "Selection and ordering data" under "Voltages").

Voltages or frequencies that are not covered by the predefined options can be ordered with order code **L1Y**. In this case, the output, voltage and frequency must be specified.

¹⁾ Can also be supplied for 400 VΔ 50 Hz with voltage code "9" and order code **L1Y** (specify output, voltage and frequency).
²⁾ For explosion-proof motors, the type of construction IM V1 without protective cover is not possible.

³⁾ The "Second shaft extension" option, order code **K16** is not possible.
⁴⁾ As special version with voltage code "9" and order code **L1Y** (specify output, voltage and frequency).

IEC Squirrel-Cage Motors

Non-standard motors frame size 315 and above

Self-ventilated motors for mains-fed operation
Cast-iron series 1LA8

Selection and ordering data (continued)

Order No.	Locked-rotor torque	Locked-rotor current	Breakdown torque	Torque class	Moment of inertia	Noise at rated output		Mech. limit speed ¹⁾	Parallel feeders required		
	At 50 Hz and for direct online starting as multiple of rated torque					Measuring surface sound pressure level at 50 Hz	Sound power level at 50 Hz		400 V	500 V	690 V
	T_{LR}/T_{rated}	I_{LR}/I_{rated}	T_B/T_{rated}	CL	J kgm ²	L_{pFA} dB(A)	L_{WA} dB(A)	n_{max} rpm			
6-pole, 1000 rpm at 50 Hz, 1200 rpm at 60 Hz, temperature class 155 (F), used acc. to temperature class 130 (B), IP55 degree of protection											
1LA8 315-6AB□□	2.0	6.3	2.5	13	6.0	68	82	2950 (2350)			
1LA8 317-6AB□□	2.0	6.3	2.5	13	7.3	68	82	2950 (2350)	Yes		
1LA8 355-6AB□□	2.2	6.5	2.8	13	13	71	86	2500 (2100)	Yes		
1LA8 357-6AB□□	2.2	6.5	2.8	13	16	71	86	2500 (2100)	Yes	Yes	Yes
1LA8 403-6AB□□	2.2	6.5	2.8	13	21	73	88	2200 (1900)/2100 ²⁾			
1LA8 405-6AB□□	2.3	6.5	2.8	13	24	73	88	2200 (1900)/2100 ²⁾	Yes		
1LA8 407-6AB□□	2.3	6.5	2.8	13	27	73	88	2200 (1900)/2100 ²⁾	Yes		
1LA8 453-6AB□□	2.0	6.5	2.6	13	35	75	90	2100 (1700)/1800 ²⁾	Yes	Yes	
1LA8 455-6AB□□	2.0	6.5	2.5	13	39	75	90	2100 (1700)/1800 ²⁾	Yes	Yes	
1LA8 457-6AB□□	2.0	6.5	2.5	13	44	75	90	2100 (1700)/1800 ²⁾	Yes	Yes	
8-pole, 750 rpm at 50 Hz, 900 rpm at 60 Hz, temperature class 155 (F), used acc. to temperature class 130 (B), IP55 degree of protection											
1LA8 315-8AB□□	2.1	6.0	2.3	13	6.0	65	79	2950 (2350)			
1LA8 317-8AB□□	2.1	6.0	2.3	13	7.3	65	79	2950 (2350)			
1LA8 355-8AB□□	2.1	6.1	2.4	13	13	67	82	2500 (2100)			
1LA8 357-8AB□□	2.1	6.1	2.4	13	16	67	82	2500 (2100)	Yes		
1LA8 403-8AB□□	2.0	6.5	2.6	13	21	69	84	2200 (1900)/2100 ²⁾			
1LA8 405-8AB□□	2.1	6.5	2.6	13	24	69	84	2200 (1900)/2100 ²⁾			
1LA8 407-8AB□□	2.1	6.5	2.6	13	27	69	84	2200 (1900)/2100 ²⁾	Yes		
1LA8 453-8AB□□	2.0	6.6	2.4	13	35	71	86	2100 (1700)/1800 ²⁾	Yes		
1LA8 455-8AB□□	2.0	6.6	2.4	13	39	71	86	2100 (1700)/1800 ²⁾	Yes	Yes	
1LA8 457-8AB□□	2.0	6.6	2.4	13	44	71	86	2100 (1700)/1800 ²⁾	Yes	Yes	

Values in brackets apply to the use of motors in hazardous areas.

¹⁾ Limit speeds for reinforced bearings (order code **K20**) for 6- and 8-pole motors on request.

²⁾ For vertical type of construction IM V1.

IEC Squirrel-Cage Motors

Non-standard motors frame size 315 and above

Self-ventilated motors for converter-fed operation
Cast-iron series 1LA8

Selection and ordering data

Rated output at		Frame size	Operating values at rated output and sinusoidal supply							Order No.	Price	Weight of IM B3 type of construction approx.
50 Hz	60 Hz		Rated speed at 50 Hz	Rated torque at 50 Hz	Efficiency at 50 Hz 4/4-load	Efficiency at 50 Hz 3/4-load	Power factor at 50 Hz 4/4-load	Rated current at 50 Hz 400 V	Rated current at 50 Hz 690 V			
P_{rated} kW	P_{rated} kW	FS	n_{rated} rpm	T_{rated} Nm	η_{rated} %	η_{rated} %	$\cos\phi_{\text{rated}}$	I_{rated} A	I_{rated} A		m kg	
2-pole, 3000 rpm at 50 Hz, 3600 rpm at 60 Hz, temperature class 155 (F), used acc. to temperature class 155 (F), IP55 degree of protection, specially for operation on SINAMICS or SIMOVERT MASTERDRIVES with standard insulation for voltages ≤500 V												
250	280	315	2979	801	96.2	96.2	0.90	415	240	1LA8 315-2PC□□	1300	
315	353	315	2979	1010	96.5	96.5	0.91	520	300	1LA8 317-2PC□□	1500	
355	398	355	2980	1140	96.5	96.5	0.90	590	340	1LA8 353-2PC□□	1900	
400	448	355	2980	1280	96.7	96.7	0.91	660	380	1LA8 355-2PC□□	2000	
500	560	355	2982	1600	97.1	97.1	0.91	820	475	1LA8 357-2PC□□	2200	
560	616	400	2985	1790	97.1	97.1	0.91	910	530	1LA8 403-2PC□□	2800	
630	693	400	2985	2020	97.1	97.1	0.91	1020	600	1LA8 405-2PC□□	3000	
710	781	400	2985	2270	97.3	97.3	0.91	–	670 ¹⁾	1LA8 407-2PC□□	3200	
800	–	450	2986	2560	97.2	97.2	0.91	–	760	1LA8 453-2PE□□	4000	
900	–	450	2986	2880	97.3	97.3	0.92	–	840	1LA8 455-2PE□□	4200	
1000	–	450	2986	3200	97.4	97.4	0.93	–	920	1LA8 457-2PE□□	4400	
4-pole, 1500 rpm at 50 Hz, 1800 rpm at 60 Hz, temperature class 155 (F), used acc. to temperature class 155 (F), IP55 degree of protection, specially for operation on SINAMICS or SIMOVERT MASTERDRIVES with standard insulation for voltages ≤500 V												
250	288	315	1488	1600	96.0	96.0	0.87	430	250 ²⁾	1LA8 315-4PB□□	1300	
315	362	315	1488	2020	96.2	96.2	0.87	540	315 ²⁾	1LA8 317-4PB□□	1500	
355	408	355	1488	2280	96.3	96.3	0.87	610	355 ²⁾	1LA8 353-4PB□□	1900	
400	460	355	1488	2570	96.4	96.4	0.87	690	400 ²⁾	1LA8 355-4PB□□	2000	
500	575	355	1488	3210	96.7	96.7	0.88	850	490 ²⁾	1LA8 357-4PB□□	2200	
560	644	400	1492	3580	96.7	96.7	0.88	950	550	1LA8 403-4PB□□	2800	
630	725	400	1492	4030	96.9	96.9	0.88	1060	620	1LA8 405-4PB□□	3000	
710	817	400	1492	4540	97.0	97.0	0.89	–	690 ¹⁾	1LA8 407-4PB□□	3200	
800	920	450	1492	5120	97.0	97.0	0.88	–	780 ¹⁾	1LA8 453-4PC□□	4000	
900	1040	450	1492	5760	97.1	97.1	0.88	–	880	1LA8 455-4PC□□	4200	
1000	1150	450	1492	6400	97.1	97.1	0.89	–	970	1LA8 457-4PC□□	4400	

Order No. supplements

Motor type	Penultimate position: Voltage code				Final position: Type of construction code			
	400 VΔ	400 VΔ/690 VY ³⁾	500 VΔ	690 VΔ ³⁾	Without flange IM B3	With flange IM V1 without protective cover ⁴⁾	IM V1 with protective cover ⁵⁾	IM B35
	4	8	5	7	0	8	4	6
1LA8 315-... □□ to 1LA8 405-... □□	○	□	○	–	□	✓ ⁶⁾	✓ ⁶⁾	✓
1LA8 407-... □□ to 1LA8 457-... □□	–	–	○	□	□	✓ ⁶⁾	✓ ⁶⁾	✓ ⁷⁾

- Standard version
- Without additional charge
- ✓ With additional charge
- Not possible

Order other voltages with voltage code **9** in the penultimate position and the corresponding order code (see "Special versions" in the "Selection and ordering data" under "Voltages").

Voltages or frequencies that are not covered by the predefined options can be ordered with order code **L1Y**. In this case, the output, voltage and frequency must be specified.

¹⁾ Can also be supplied for 400 VΔ 50 Hz with voltage code **9** and order code **L1Y** (specify output, voltage and frequency).
²⁾ **Standardline** for 1LA8 motors is a standardized range in specific versions which can be ordered with the order code **B20**. The delivery time is 4 weeks. Scope of the **Standardline**: 4-pole, types **1LA8 315**, **1LA8 317**, **1LA8 353**, **1LA8 355**, type of construction code **0** (IM B3), voltage code **4** (400 VΔ), **8** (400 VΔ/690 VY) or **5** (500 VΔ); can be ordered for converter-fed operation, but not in 690 V version. Possible order codes: **A23**, **A61**, **A72**, **G50**, **H70**, **H73**, **K09**, **K10**, **K45**, **K46**, **K57**, **K83**, **K84**, **K85**, **L00**, **L97**, **M58** (for frame size 315 only), **M88**, **Y53**.

³⁾ Motors with standard insulation can only be operated with converter circuit (du/dt or sinusoidal filter).
⁴⁾ For explosion-proof motors, the type of construction IM V1 without protective cover is not possible.
⁵⁾ The "Second shaft extension" option, order code **K16** is not possible.
⁶⁾ In 2-pole motors 60 Hz version, not possible for 1LA8 353 to 1LA8 457.
⁷⁾ In 2-pole motors 60 Hz version, not possible for 1LA8 453 to 1LA8 457.

IEC Squirrel-Cage Motors

Non-standard motors frame size 315 and above

Self-ventilated motors for converter-fed operation
Cast-iron series 1LA8

Selection and ordering data (continued)

Order No.	At 50 Hz as multiple of rated torque	Torque class	Moment of inertia	Noise		Mech. limit speed ¹⁾		Parallel feeders required		
				Measuring surface sound pressure level at 50 Hz For rated output and sinusoidal supply, 50 Hz, tolerance +3 dB(A)	Sound power level at 50 Hz	n_{\max} rpm	f_{\max} Hz	400 V	500 V	690 V
	T_B/T_{rated}	CL	J kgm ²	L_{pFA} dB(A)	L_{WA} dB(A)					
2-pole, 3000 rpm at 50 Hz, 3600 rpm at 60 Hz, temperature class 155 (F), used acc. to temperature class 155 (F), IP55 degree of protection, specially for operation on SINAMICS or SIMOVERT MASTERDRIVES with standard insulation for voltages ≤500 V										
1LA8 315-2PC□□	2.8	10	2.7	82 (75) ²⁾	97 (90) ²⁾	3600	60		Yes	
1LA8 317-2PC□□	2.8	10	3.3	82 (75) ²⁾	97 (90) ²⁾	3600	60		Yes	
1LA8 353-2PC□□	2.5	10	4.8	77 ³⁾	92 ³⁾	3600/3100 ⁴⁾	60/52 ⁴⁾	Yes	Yes	
1LA8 355-2PC□□	2.5	10	5.3	77 ³⁾	92 ³⁾	3600/3100 ⁴⁾	60/52 ⁴⁾	Yes	Yes	
1LA8 357-2PC□□	2.6	10	6.4	77 ³⁾	92 ³⁾	3600/3100 ⁴⁾	60/52 ⁴⁾	Yes		
1LA8 403-2PC□□	2.8	10	8.6	79 ³⁾	94 ³⁾	3600/3100 ⁴⁾	60/52 ⁴⁾	Yes		
1LA8 405-2PC□□	2.8	10	9.6	79 ³⁾	94 ³⁾	3600/3100 ⁴⁾	60/52 ⁴⁾	Yes	Yes	
1LA8 407-2PC□□	2.8	10	11	79 ³⁾	94 ³⁾	3600/3100 ⁴⁾	60/52 ⁴⁾	Yes		
1LA8 453-2PE□□	3.0	5	19	81 ³⁾	96 ³⁾	3000	50		Yes	
1LA8 455-2PE□□	2.8	5	21	81 ³⁾	96 ³⁾	3000	50		Yes	Yes
1LA8 457-2PE□□	2.7	5	23	81 ³⁾	96 ³⁾	3000	50		Yes	Yes
4-pole, 1500 rpm at 50 Hz, 1800 rpm at 60 Hz, temperature class 155 (F), used acc. to temperature class 155 (F), IP55 degree of protection, specially for operation on SINAMICS or SIMOVERT MASTERDRIVES with standard insulation for voltages ≤500 V										
1LA8 315-4PB□□	2.8	13	3.6	73	87	3000 (2650)	100 (88)		Yes	
1LA8 317-4PB□□	2.8	13	4.4	73	87	3000 (2650)	100 (88)		Yes	
1LA8 353-4PB□□	2.6	13	6.1	75	90	2500 (2350)	83 (78)	Yes	Yes	
1LA8 355-4PB□□	2.6	13	6.8	75	90	2500 (2350)	83 (78)	Yes	Yes	
1LA8 357-4PB□□	2.4	13	8.5	75	90	2500 (2350)	83 (78)	Yes		
1LA8 403-4PB□□	2.7	13	13	78	93	2200 (2100)/2100 ⁴⁾	73 (70)/70 ⁴⁾	Yes		
1LA8 405-4PB□□	2.7	13	14	78	93	2200 (2100)/2100 ⁴⁾	73 (70)/70 ⁴⁾	Yes	Yes	
1LA8 407-4PB□□	2.7	13	16	78	93	2200 (2100)/2100 ⁴⁾	73 (70)/70 ⁴⁾	Yes		
1LA8 453-4PC□□	2.6	10	23	81	96	2100 (1900)/1800 ⁴⁾	70 (63)/60 ⁴⁾	Yes		
1LA8 455-4PC□□	2.6	10	26	81	96	2100 (1900)/1800 ⁴⁾	70 (63)/60 ⁴⁾	Yes	Yes	
1LA8 457-4PC□□	2.6	10	28	81	96	2100 (1900)/1800 ⁴⁾	70 (63)/60 ⁴⁾	Yes	Yes	

Values in brackets apply to the use of motors in hazardous areas.

¹⁾ Limit speeds for reinforced bearings (order code **K20**) for 4-pole motors on request.

²⁾ Low-noise version, 2-pole, in brackets. To reduce noise, 2-pole motors can be equipped with an axial fan that is only suitable for one direction of rotation. Clockwise rotation order code **K37**, counter-clockwise rotation **K38**.

³⁾ In the standard version, the motors already have an axial fan for clockwise rotation. Order code **K37** is not necessary. For counter-clockwise rotation, order code **K38** is necessary.

⁴⁾ For vertical type of construction IM V1.

IEC Squirrel-Cage Motors

Non-standard motors frame size 315 and above

Self-ventilated motors for converter-fed operation
Cast-iron series 1LA8

Selection and ordering data (continued)

Rated output at		Frame size	Operating values at rated output and sinusoidal supply							Order No.	Price	Weight of IM B3 type of construction approx.
50 Hz	60 Hz		Rated speed at 50 Hz	Rated torque at 50 Hz	Efficiency at 50 Hz 4/4-load	Efficiency at 50 Hz 3/4-load	Power factor at 50 Hz 4/4-load	Rated current at 50 Hz 400 V	Rated current at 50 Hz 690 V			
P_{rated} kW	P_{rated} kW	FS	n_{rated} rpm	T_{rated} Nm	η_{rated} %	η_{rated} %	$\cos\phi_{\text{rated}}$	I_{rated} A	I_{rated} A	For Order No. supplements for voltage and type of construction, see table below	m kg	
6-pole, 1000 rpm at 50 Hz, 1200 rpm at 60 Hz, temperature class 155 (F), used acc. to temperature class 155 (F), IP55 degree of protection, specially for operation on SINAMICS or SIMOVERT MASTERDRIVES with standard insulation for voltages ≤500 V												
200	230	315	988	1930	95.7	95.8	0.86	345	200	1LA8 315-6PBQQ	1300	
250	288	315	988	2410	95.9	96.0	0.86	430	250	1LA8 317-6PBQQ	1500	
315	362	355	993	3040	96.2	96.2	0.86	540	315	1LA8 355-6PBQQ	2000	
400	460	355	993	3850	96.5	96.5	0.86	690	400	1LA8 357-6PBQQ	2200	
450	518	400	991	4330	96.5	96.5	0.86	780	455	1LA8 403-6PBQQ	2800	
500	575	400	991	4810	96.5	96.5	0.86	860	500	1LA8 405-6PBQQ	3000	
560	644	400	991	5390	96.7	96.7	0.86	960	560	1LA8 407-6PBQQ	3200	
630	725	450	993	6060	96.8	96.8	0.86	1100	630	1LA8 453-6PBQQ	4000	
710	817	450	993	6830	96.8	96.8	0.86	–	710 ¹⁾	1LA8 455-6PBQQ	4200	
800	920	450	993	7690	97.0	97.1	0.86	–	790 ¹⁾	1LA8 457-6PBQQ	4500	
8-pole, 750 rpm at 50 Hz, 900 rpm at 60 Hz, temperature class 155 (F), used acc. to temperature class 155 (F), IP55 degree of protection, specially for operation on SINAMICS or SIMOVERT MASTERDRIVES with standard insulation for voltages ≤500 V												
160	184	315	739	2070	94.9	94.9	0.82	295	172	1LA8 315-8PBQQ	1300	
200	230	315	739	2580	95.2	95.2	0.82	370	215	1LA8 317-8PBQQ	1500	
250	288	355	741	3220	95.7	95.7	0.82	460	265	1LA8 355-8PBQQ	2000	
315	362	355	741	4060	96.0	96.0	0.82	580	335	1LA8 357-8PBQQ	2200	
355	408	400	742	4570	96.1	96.1	0.82	650	375	1LA8 403-8PBQQ	2800	
400	460	400	742	5150	96.2	96.2	0.82	730	425	1LA8 405-8PBQQ	3000	
450	518	400	742	5790	96.3	96.3	0.82	820	475	1LA8 407-8PBQQ	3200	
500	575	450	744	6420	96.4	96.4	0.81	920	540	1LA8 453-8PBQQ	4000	
560	644	450	744	7190	96.5	96.5	0.81	1040	600	1LA8 455-8PBQQ	4200	
630	725	450	744	8090	96.6	96.6	0.81	1160	670	1LA8 457-8PBQQ	4500	

Order No. supplements

Motor type	Penultimate position: Voltage code				Final position: Type of construction code			
	400 VA	400 VA/690 VY ²⁾	500 VA	690 VA ²⁾	Without flange IM B3	With flange IM V1 without protective cover ³⁾	IM V1 with protective cover ⁴⁾	IM B35
	4	8	5	7	0	8	4	6
6-pole								
1LA8 315-... QQ to 1LA8 453-... QQ	○	□	○	–	□	✓	✓	✓
1LA8 455-... QQ to 1LA8 457-... QQ	–	–	○	□	□	✓	✓	✓
8-pole								
1LA8 315-... QQ to 1LA8 457-... QQ	○	□	○	– ⁵⁾	□	✓	✓	✓

- Standard version
- Without additional charge
- ✓ With additional charge
- Not possible

Order other voltages with voltage code **9** in the penultimate position and the corresponding order code (see "Special versions" in the "Selection and ordering data" under "Voltages").

Voltages or frequencies that are not covered by the predefined options can be ordered with order code **L1Y**. In this case, the output, voltage and frequency must be specified.

¹⁾ Can also be supplied for 400 VA 50 Hz with voltage code **9** and order code **L1Y** (specify output, voltage and frequency).
²⁾ Motors with standard insulation can only be operated with converter circuit (du/dt or sinusoidal filter).

³⁾ For explosion-proof motors, the type of construction IM V1 without protective cover is not possible.
⁴⁾ The "Second shaft extension" option, order code **K16** is not possible.
⁵⁾ As special version with voltage code **9** and order code **L1Y** (specify output, voltage and frequency).

IEC Squirrel-Cage Motors

Non-standard motors frame size 315 and above

Self-ventilated motors for converter-fed operation
Cast-iron series 1LA8

Selection and ordering data (continued)

Order No.	At 50 Hz as multiple of rated torque	Torque class	Moment of inertia	Noise		Mech. limit speed ¹⁾		Parallel feeders required		
				Measuring surface sound pressure level at 50 Hz For rated output and sinusoidal supply, 50 Hz, tolerance +3 dB(A)	Sound power level at 50 Hz	n_{\max} rpm	f_{\max} Hz	400 V	500 V	690 V
	T_B/T_{rated}	CL	J kgm ²	L_{pFA} dB(A)	L_{WA} dB(A)					
6-pole, 1000 rpm at 50 Hz, 1200 rpm at 60 Hz, temperature class 155 (F), used acc. to temperature class 155 (F), IP55 degree of protection, specially for operation on SINAMICS or SIMOVERT MASTERDRIVES with standard insulation for voltages ≤500 V										
1LA8 315-6PB□□	2.5	13	6.0	68	82	2950 (2350)	147 (117)			
1LA8 317-6PB□□	2.5	13	7.3	68	82	2950 (2350)	147 (117)	Yes		
1LA8 355-6PB□□	2.8	13	13	71	86	2500 (2100)	125 (105)	Yes		
1LA8 357-6PB□□	2.8	13	16	71	86	2500 (2100)	125 (105)	Yes	Yes	
1LA8 403-6PB□□	2.8	13	21	73	88	2200 (1900)/2100 ²⁾	110 (95)/105 ²⁾			
1LA8 405-6PB□□	2.8	13	24	73	88	2200 (1900)/2100 ²⁾	110 (95)/105 ²⁾	Yes		
1LA8 407-6PB□□	2.8	13	27	73	88	2200 (1900)/2100 ²⁾	110 (95)/105 ²⁾	Yes		
1LA8 453-6PB□□	2.6	13	35	75	90	2100 (1700)/1800 ²⁾	105 (85)/90 ²⁾	Yes	Yes	
1LA8 455-6PB□□	2.5	13	39	75	90	2100 (1700)/1800 ²⁾	105 (85)/90 ²⁾		Yes	
1LA8 457-6PB□□	2.5	13	44	75	90	2100 (1700)/1800 ²⁾	105 (85)/90 ²⁾		Yes	
8-pole, 750 rpm at 50 Hz, 900 rpm at 60 Hz, temperature class 155 (F), used acc. to temperature class 155 (F), IP55 degree of protection, specially for operation on SINAMICS or SIMOVERT MASTERDRIVES with standard insulation for voltages ≤500 V										
1LA8 315-8PB□□	2.3	13	6.0	65	79	2950 (2350)	196 (156)			
1LA8 317-8PB□□	2.3	13	7.3	65	79	2950 (2350)	196 (156)			
1LA8 355-8PB□□	2.4	13	13	67	82	2500 (2100)	166 (140)			
1LA8 357-8PB□□	2.4	13	16	67	82	2500 (2100)	166 (140)	Yes		
1LA8 403-8PB□□	2.6	13	21	69	84	2200 (1900)/2100 ²⁾	146 (126)/140 ²⁾			
1LA8 405-8PB□□	2.6	13	24	69	84	2200 (1900)/2100 ²⁾	146 (126)/140 ²⁾			
1LA8 407-8PB□□	2.6	13	27	69	84	2200 (1900)/2100 ²⁾	146 (126)/140 ²⁾	Yes		
1LA8 453-8PB□□	2.4	13	35	71	86	2100 (1700)/1800 ²⁾	140 (113)/120 ²⁾	Yes		
1LA8 455-8PB□□	2.4	13	39	71	86	2100 (1700)/1800 ²⁾	140 (113)/120 ²⁾	Yes	Yes	
1LA8 457-8PB□□	2.4	13	44	71	86	2100 (1700)/1800 ²⁾	140 (113)/120 ²⁾	Yes	Yes	

Values in brackets apply to the use of motors in hazardous areas.

¹⁾ Limit speeds for reinforced bearings (order code **K20**) for 6- and 8-pole motors on request.

²⁾ For vertical type of construction IM V1.

IEC Squirrel-Cage Motors

Non-standard motors frame size 315 and above

Self-ventilated motors for converter-fed operation Cast-iron series 1LA8

Selection and ordering data (continued)

Rated output at		Frame size	Operating values at rated output and sinusoidal supply						Order No.	Price	Weight of IM B3 type of construction approx.
50 Hz	60 Hz		Rated speed at 50 Hz	Rated torque at 50 Hz	Efficiency at 50 Hz 4/4-load	Efficiency at 50 Hz 3/4-load	Power factor at 50 Hz 4/4-load	Rated current at 50 Hz 690 V			
P_{rated} kW	P_{rated} kW	FS	n_{rated} rpm	T_{rated} Nm	η_{rated} %	η_{rated} %	$\cos\phi_{\text{rated}}$	I_{rated} A		m kg	
2-pole, 3000 rpm at 50 Hz, 3600 rpm at 60 Hz, temperature class 155 (F), used acc. to temperature class 155 (F), IP55 degree of protection, specially for operation on SINAMICS or SIMOVERT MASTERDRIVES with special insulation for voltages >500 to 690 V											
240	270	315	2978	770	96.0	96.0	0.90	230	1LA8 315-2PM8□	1300	
300	335	315	2978	962	96.4	96.4	0.91	285	1LA8 317-2PM8□	1500	
345	385	355	2981	1105	96.4	96.4	0.90	335	1LA8 353-2PM8□	1900	
390	435	355	2981	1249	96.6	96.6	0.91	370	1LA8 355-2PM8□	2000	
485	545	355	2982	1553	97.0	97.0	0.91	460	1LA8 357-2PM8□	2200	
545	600	400	2986	1743	97.1	97.1	0.91	520	1LA8 403-2PM7□	2800	
610	670	400	2986	1951	97.1	97.1	0.91	580	1LA8 405-2PM7□	3000	
680	750	400	2986	2175	97.2	97.2	0.92	640	1LA8 407-2PM7□	3200	
775	-	450	2987	2478	97.2	97.2	0.92	730	1LA8 453-2PM7□	4000	
875	-	450	2987	2798	97.3	97.3	0.92	820	1LA8 455-2PM7□	4200	
970	-	450	2987	3101	97.4	97.4	0.93	900	1LA8 457-2PM7□	4400	
4-pole, 1500 rpm at 50 Hz, 1800 rpm at 60 Hz, temperature class 155 (F), used acc. to temperature class 155 (F), IP55 degree of protection, specially for operation on SINAMICS or SIMOVERT MASTERDRIVES with special insulation for voltages >500 to 690 V											
235	270	315	1485	1511	95.8	95.8	0.87	235	1LA8 315-4PM8□	1300	
290	335	315	1485	1865	95.9	95.9	0.87	285	1LA8 317-4PM8□	1500	
340	390	355	1488	2182	96.0	96.0	0.87	340	1LA8 353-4PM8□	1900	
385	445	355	1488	2471	96.2	96.2	0.87	385	1LA8 355-4PM8□	2000	
480	550	355	1488	3081	96.4	96.4	0.87	480	1LA8 357-4PM8□	2200	
545	625	400	1491	3491	96.5	96.5	0.88	540	1LA8 403-4PM8□	2800	
615	710	400	1491	3939	96.7	96.7	0.88	600	1LA8 405-4PM8□	3000	
690	795	400	1491	4420	96.9	96.9	0.89	670	1LA8 407-4PM7□	3200	
785	905	450	1492	5025	96.8	96.8	0.88	770	1LA8 453-4PM7□	4000	
880	1010	450	1492	5633	97.0	97.0	0.87	870	1LA8 455-4PM7□	4200	
980	1125	450	1492	6273	97.1	97.1	0.89	950	1LA8 457-4PM7□	4400	

Order No. supplements

Motor type	Final position: Type of construction code			
	Without flange IM B3	With flange IM V1 without protective cover	IM V1 with protective cover	IM B35
1LA8 315-... □□ to 1LA8 457-... □□	0	8	4	6
	□	✓	✓	✓

- Standard version
- ✓ With additional charge

The voltage code is already in the Order No. as the penultimate position.

Assignment:

7 = 690 VΔ

8 = 400 VΔ/690 VY

Order other voltages with voltage code **9** in the penultimate position and the corresponding order code (see "Special versions" in the "Selection and ordering data" under "Voltages").

Voltages or frequencies that are not covered by the predefined options can be ordered with order code **L1Y**. In this case, the output, voltage and frequency must be specified.

IEC Squirrel-Cage Motors

Non-standard motors frame size 315 and above

Self-ventilated motors for converter-fed operation
Cast-iron series 1LA8

Selection and ordering data (continued)

Order No.	Breakdown torque at 50 Hz as multiple of rated torque	Torque class	Moment of inertia	Noise		Mech. limit speed ¹⁾		Parallel feeders required		
	T_B/T_{rated}	CL	J kgm ²	Measuring surface sound pressure level at 50 Hz For rated output and sinusoidal supply, 50 Hz, tolerance +3 dB(A) L_{pFA} dB(A)	Sound power level at 50 Hz L_{WA} dB(A)	n_{max} rpm	f_{max} Hz	400 V	500 V	690 V
2-pole, 3000 rpm at 50 Hz, 3600 rpm at 60 Hz, temperature class 155 (F), used acc. to temperature class 155 (F), IP55 degree of protection, specially for operation on SINAMICS or SIMOVERT MASTERDRIVES with special insulation for voltages >500 to 690 V										
1LA8 315-2PM8□	3.0	10	2.7	82 (75) ²⁾	97 (90) ²⁾	3600	60	Yes		
1LA8 317-2PM8□	3.0	10	3.3	82 (75) ²⁾	97 (90) ²⁾	3600	60	Yes		
1LA8 353-2PM8□	2.6	10	4.8	77 ³⁾	92 ³⁾	3600/3100 ⁴⁾	60/52 ⁴⁾	Yes	Yes	
1LA8 355-2PM8□	2.6	10	5.3	77 ³⁾	92 ³⁾	3600/3100 ⁴⁾	60/52 ⁴⁾	Yes	Yes	
1LA8 357-2PM8□	2.6	10	6.4	77 ³⁾	92 ³⁾	3600/3100 ⁴⁾	60/52 ⁴⁾	Yes		
1LA8 403-2PM7□	3.0	10	8.6	79 ³⁾	94 ³⁾	3600/3100 ⁴⁾	60/52 ⁴⁾	Yes		
1LA8 405-2PM7□	3.1	10	9.6	79 ³⁾	94 ³⁾	3600/3100 ⁴⁾	60/52 ⁴⁾	Yes	Yes	
1LA8 407-2PM7□	3.0	10	11	79 ³⁾	94 ³⁾	3600/3100 ⁴⁾	60/52 ⁴⁾	Yes		
1LA8 453-2PM7□	2.8	5	19	81 ³⁾	96 ³⁾	3000	50	Yes		
1LA8 455-2PM7□	2.8	5	21	81 ³⁾	96 ³⁾	3000	50	Yes	Yes	
1LA8 457-2PM7□	2.8	5	23	81 ³⁾	96 ³⁾	3000	50	Yes	Yes	
4-pole, 1500 rpm at 50 Hz, 1800 rpm at 60 Hz, temperature class 155 (F), used acc. to temperature class 155 (F), IP55 degree of protection, specially for operation on SINAMICS or SIMOVERT MASTERDRIVES with special insulation for voltages >500 to 690 V										
1LA8 315-4PM8□	2.8	13	3.6	73	87	3000 (2650)	100 (88)	Yes		
1LA8 317-4PM8□	2.8	13	4.4	73	87	3000 (2650)	100 (88)	Yes		
1LA8 353-4PM8□	2.6	13	6.1	75	90	2500 (2350)	83 (78)	Yes	Yes	
1LA8 355-4PM8□	2.6	13	6.8	75	90	2500 (2350)	83 (78)	Yes	Yes	
1LA8 357-4PM8□	2.5	13	8.5	75	90	2500 (2350)	83 (78)	Yes		
1LA8 403-4PM8□	2.6	13	13	78	93	2200 (2100)/2100 ⁴⁾	73 (70)/70 ⁴⁾	Yes		
1LA8 405-4PM8□	2.7	13	14	78	93	2200 (2100)/2100 ⁴⁾	73 (70)/70 ⁴⁾	Yes	Yes	
1LA8 407-4PM7□	2.6	13	16	78	93	2200 (2100)/2100 ⁴⁾	73 (70)/70 ⁴⁾	Yes		
1LA8 453-4PM7□	2.5	10	23	81	96	2100 (1900)/1800 ⁴⁾	70 (63)/60 ⁴⁾	Yes		
1LA8 455-4PM7□	2.6	10	26	81	96	2100 (1900)/1800 ⁴⁾	70 (63)/60 ⁴⁾	Yes	Yes	
1LA8 457-4PM7□	2.6	10	28	81	96	2100 (1900)/1800 ⁴⁾	70 (63)/60 ⁴⁾	Yes	Yes	

Values in brackets apply to the use of motors in hazardous areas.

¹⁾ Limit speeds for reinforced bearings (order code **K20**) for 4-pole motors on request.

²⁾ Low-noise version, 2-pole, in brackets. To reduce noise, 2-pole motors can be equipped with an axial fan that is only suitable for one direction of rotation. Clockwise rotation order code **K37**, counter-clockwise rotation **K38**.

³⁾ In the standard version, the motors already have an axial fan for clockwise rotation. Order code **K37** is not necessary. For counter-clockwise rotation, order code **K38** is necessary.

⁴⁾ For vertical type of construction IM V1.

IEC Squirrel-Cage Motors

Non-standard motors frame size 315 and above

Self-ventilated motors for converter-fed operation
Cast-iron series 1LA8

Selection and ordering data (continued)

Rated output at		Frame size	Operating values at rated output and sinusoidal supply						Order No.	Price	Weight of IM B3 type of construction approx.
50 Hz	60 Hz		Rated speed at 50 Hz	Rated torque at 50 Hz	Efficiency at 50 Hz 4/4-load	Efficiency at 50 Hz 3/4-load	Power factor at 50 Hz 4/4-load	Rated current at 50 Hz 690 V			
P_{rated} kW	P_{rated} kW	FS	n_{rated} rpm	T_{rated} Nm	η_{rated} %	η_{rated} %	$\cos\varphi_{\text{rated}}$	I_{rated} A		m kg	
6-pole, 1000 rpm at 50 Hz, 1200 rpm at 60 Hz, temperature class 155 (F), used acc. to temperature class 155 (F), IP55 degree of protection, specially for operation on SINAMICS or SIMOVERT MASTERDRIVES with special insulation for voltages >500 to 690 V											
190	220	315	990	1833	95.5	95.6	0.85	196	1LA8 315-6PM8□	1300	
235	270	315	990	2267	95.7	95.8	0.86	240	1LA8 317-6PM8□	1500	
300	345	355	992	2888	96.2	96.2	0.86	305	1LA8 355-6PM8□	2000	
380	435	355	992	3658	96.4	96.4	0.86	385	1LA8 357-6PM8□	2200	
435	500	400	993	4184	96.4	96.4	0.85	445	1LA8 403-6PM8□	2800	
485	560	400	993	4664	96.5	96.5	0.86	490	1LA8 405-6PM8□	3000	
545	625	400	993	5241	96.6	96.6	0.86	550	1LA8 407-6PM8□	3200	
615	705	450	993	5915	96.8	96.8	0.84	630	1LA8 453-6PM8□	4000	
690	795	450	993	6636	96.8	96.8	0.85	700	1LA8 455-6PM7□	4200	
780	895	450	993	7502	96.9	97.0	0.85	790	1LA8 457-6PM7□	4500	
8-pole, 750 rpm at 50 Hz, 900 rpm at 60 Hz, temperature class 155 (F), used acc. to temperature class 155 (F), IP55 degree of protection, specially for operation on SINAMICS or SIMOVERT MASTERDRIVES with special insulation for voltages >500 to 690 V											
145	165	315	740	1871	94.6	94.6	0.79	162	1LA8 315-8PM8□	1300	
180	205	315	740	2323	94.9	94.9	0.80	198	1LA8 317-8PM8□	1500	
230	265	355	743	2956	95.5	95.5	0.80	250	1LA8 355-8PM8□	2000	
290	335	355	743	3727	95.7	95.7	0.81	315	1LA8 357-8PM8□	2200	
335	385	400	743	4306	96.0	96.0	0.80	365	1LA8 403-8PM8□	2800	
375	430	400	743	4820	96.1	96.1	0.80	410	1LA8 405-8PM8□	3000	
425	490	400	743	5463	96.2	96.2	0.79	470	1LA8 407-8PM8□	3200	
485	560	450	745	6217	96.5	96.5	0.78	540	1LA8 453-8PM8□	4000	
545	625	450	745	6986	96.6	96.6	0.78	610	1LA8 455-8PM8□	4200	
600	690	450	745	7691	96.7	96.7	0.79	660	1LA8 457-8PM8□	4500	

Order No. supplements

Motor type	Final position: Type of construction code			
	Without flange		With flange	
	IM B3	IM V1 without protective cover	IM V1 with protective cover	IM B35
	0	8	4	6
1LA8 315-... □□ to 1LA8 457-... □□	□	✓	✓	✓

- Standard version
- ✓ With additional charge

The voltage code is already in the Order No. as the penultimate position.

Assignment:

7 = 690 VΔ

8 = 400 VΔ/690 VY

Order other voltages with voltage code **9** in the penultimate position and the corresponding order code (see "Special versions" in the "Selection and ordering data" under "Voltages").

Voltages or frequencies that are not covered by the predefined options can be ordered with order code **L1Y**. In this case, the output, voltage and frequency must be specified.

IEC Squirrel-Cage Motors

Non-standard motors frame size 315 and above

Self-ventilated motors for converter-fed operation
Cast-iron series 1LA8

Selection and ordering data (continued)

Order No.	Breakdown torque at 50 Hz as multiple of rated torque T_B/T_{rated}	Torque class CL	Moment of inertia J kgm ²	Noise		Mech. limit speed ¹⁾		Parallel feeders required		
				Measuring surface sound pressure level at 50 Hz For rated output and sinusoidal supply, 50 Hz, tolerance +3 dB(A) L_{pFA} dB(A)	Sound power level at 50 Hz L_{WA} dB(A)	$n_{max.}$ rpm	$f_{max.}$ Hz	400 V	500 V	690 V
6-pole, 1000 rpm at 50 Hz, 1200 rpm at 60 Hz, temperature class 155 (F), used acc. to temperature class 155 (F), IP55 degree of protection, specially for operation on SINAMICS or SIMOVERT MASTERDRIVES with special insulation for voltages >500 to 690 V										
1LA8 315-6PM8□	2.7	13	6.0	68	82	2950 (2350)	147 (117)			
1LA8 317-6PM8□	2.7	13	7.3	68	82	2950 (2350)	147 (117)	Yes		
1LA8 355-6PM8□	2.8	13	13	71	86	2500 (2100)	125 (105)	Yes		
1LA8 357-6PM8□	2.9	13	16	71	86	2500 (2100)	125 (105)	Yes	Yes	
1LA8 403-6PM8□	2.8	13	21	73	88	2200 (1900)/2100 ²⁾	110 (95)/105 ²⁾			
1LA8 405-6PM8□	2.8	13	24	73	88	2200 (1900)/2100 ²⁾	110 (95)/105 ²⁾	Yes		
1LA8 407-6PM8□	2.7	13	27	73	88	2200 (1900)/2100 ²⁾	110 (95)/105 ²⁾	Yes		
1LA8 453-6PM8□	2.7	13	35	75	90	2100 (1700)/1800 ²⁾	105 (85)/90 ²⁾	Yes	Yes	
1LA8 455-6PM7□	2.5	13	39	75	90	2100 (1700)/1800 ²⁾	105 (85)/90 ²⁾		Yes	
1LA8 457-6PM7□	2.6	13	44	75	90	2100 (1700)/1800 ²⁾	105 (85)/90 ²⁾		Yes	
8-pole, 750 rpm at 50 Hz, 900 rpm at 60 Hz, temperature class 155 (F), used acc. to temperature class 155 (F), IP55 degree of protection, specially for operation on SINAMICS or SIMOVERT MASTERDRIVES with special insulation for voltages >500 to 690 V										
1LA8 315-8PM8□	2.5	13	6.0	65	79	2950 (2350)	196 (156)			
1LA8 317-8PM8□	2.5	13	7.3	65	79	2950 (2350)	196 (156)			
1LA8 355-8PM8□	2.4	13	13	67	82	2500 (2100)	166 (140)			
1LA8 357-8PM8□	2.4	13	16	67	82	2500 (2100)	166 (140)	Yes		
1LA8 403-8PM8□	2.6	13	21	69	84	2200 (1900)/2100 ²⁾	146 (126)/140 ²⁾			
1LA8 405-8PM8□	2.7	13	24	69	84	2200 (1900)/2100 ²⁾	146 (126)/140 ²⁾			
1LA8 407-8PM8□	2.7	13	27	69	84	2200 (1900)/2100 ²⁾	146 (126)/140 ²⁾	Yes		
1LA8 453-8PM8□	2.5	13	35	71	86	2100 (1700)/1800 ²⁾	140 (113)/120 ²⁾	Yes		
1LA8 455-8PM8□	2.5	13	39	71	86	2100 (1700)/1800 ²⁾	140 (113)/120 ²⁾	Yes	Yes	
1LA8 457-8PM8□	2.5	13	44	71	86	2100 (1700)/1800 ²⁾	140 (113)/120 ²⁾	Yes	Yes	

Values in brackets apply to the use of motors in hazardous areas.

¹⁾ Limit speeds for reinforced bearings (order code **K20**) for 6- and 8-pole motors on request.

²⁾ For vertical type of construction IM V1.

IEC Squirrel-Cage Motors

Non-standard motors frame size 315 and above

Forced-air cooled motors with separately driven fan for converter-fed operation – Cast-iron series 1PQ8

Selection and ordering data

Rated output at		Frame size	Operating values at rated output and sinusoidal supply							Order No.	Price	Weight of IM B3 type of construction approx.
50 Hz	60 Hz		Rated speed at 50 Hz	Rated torque at 50 Hz	Efficiency at 50 Hz 4/4-load	Efficiency at 50 Hz 3/4-load	Power factor at 50 Hz 4/4-load	Rated current at 50 Hz 400 V	Rated current at 50 Hz 690 V			
P_{rated} kW	P_{rated} kW	FS	n_{rated} rpm	T_{rated} Nm	η_{rated} %	η_{rated} %	$\cos \varphi_{rated}$	I_{rated} A	I_{rated} A		m kg	
2-pole, 3000 rpm at 50 Hz, 3600 rpm at 60 Hz, temperature class 155 (F), used acc. to temperature class 155 (F), IP55 degree of protection, specially for operation on SINAMICS or SIMOVERT MASTERDRIVES with standard insulation for voltages ≤500 V												
250	280	315	2979	801	96.2	96.2	0.90	415	240	1PQ8 315-2PC□□	1400	
315	353	315	2979	1010	96.5	96.5	0.91	520	300	1PQ8 317-2PC□□	1600	
355	398	355	2980	1140	96.5	96.5	0.90	590	340	1PQ8 353-2PC□□	2000	
400	448	355	2980	1280	96.7	96.7	0.91	660	380	1PQ8 355-2PC□□	2100	
500	560	355	2982	1600	97.1	97.1	0.91	820	475	1PQ8 357-2PC□□	2300	
560	616	400	2985	1790	97.1	97.1	0.91	910	530	1PQ8 403-2PC□□	2900	
630	693	400	2985	2020	97.1	97.1	0.91	1020	600	1PQ8 405-2PC□□	3100	
710	781	400	2985	2270	97.3	97.3	0.91	–	670 ¹⁾	1PQ8 407-2PC□□	3300	
800	–	450	2986	2560	97.2	97.2	0.91	–	760	1PQ8 453-2PE□□	4100	
900	–	450	2986	2880	97.3	97.3	0.92	–	840	1PQ8 455-2PE□□	4300	
1000	–	450	2986	3200	97.4	97.4	0.93	–	920	1PQ8 457-2PE□□	4500	
4-pole, 1500 rpm at 50 Hz, 1800 rpm at 60 Hz, temperature class 155 (F), used acc. to temperature class 155 (F), IP55 degree of protection, specially for operation on SINAMICS or SIMOVERT MASTERDRIVES with standard insulation for voltages ≤500 V												
250	288	315	1488	1600	96.0	96.0	0.87	430	250	1PQ8 315-4PB□□	1400	
315	362	315	1488	2020	96.2	96.2	0.87	540	315	1PQ8 317-4PB□□	1600	
355	408	355	1488	2280	96.3	96.3	0.87	610	355	1PQ8 353-4PB□□	2000	
400	460	355	1488	2570	96.4	96.4	0.87	690	400	1PQ8 355-4PB□□	2100	
500	575	355	1488	3210	96.7	96.7	0.88	850	490	1PQ8 357-4PB□□	2300	
560	644	400	1492	3580	96.7	96.7	0.88	950	550	1PQ8 403-4PB□□	2900	
630	725	400	1492	4030	96.9	96.9	0.88	1060	620	1PQ8 405-4PB□□	3100	
710	817	400	1492	4540	97.0	97.0	0.89	–	690 ¹⁾	1PQ8 407-4PB□□	3300	
800	920	450	1492	5120	97.0	97.0	0.88	–	780 ¹⁾	1PQ8 453-4PC□□	4100	
900	1040	450	1492	5760	97.1	97.1	0.88	–	880	1PQ8 455-4PC□□	4300	
1000	1150	450	1492	6400	97.1	97.1	0.89	–	970	1PQ8 457-4PC□□	4500	

Order No. supplements

Motor type	Penultimate position: Voltage code				Final position: Type of construction code			
	400 VΔ	400 VΔ/690 VY ²⁾	500 VΔ	690 VΔ ²⁾	Without flange IM B3	With flange IM V1 without protective cover ³⁾	IM V1 with protective cover ⁴⁾	IM B35
	4	8	5	7	0	8	4	6
1PQ8 315-...□□ to 1PQ8 405-...□□	○	□	○	–	□	✓	✓	✓
1PQ8 407-...□□ to 1PQ8 457-...□□	–	–	○	□	□	✓	✓	✓

- Standard version
- Without additional charge
- ✓ With additional charge
- Not possible

Order other voltages with voltage code **9** in the penultimate position and the corresponding order code (see "Special versions" in the "Selection and ordering data" under "Voltages").

Voltages or frequencies that are not covered by the predefined options can be ordered with order code **L1Y**. In this case, the output, voltage and frequency must be specified.

¹⁾ Can also be supplied for 400 VΔ 50 Hz with voltage code "9" and order code **L1Y** (specify output, voltage and frequency).
²⁾ Motors with standard insulation can only be operated with converter circuit (du/dt or sinusoidal filter).

³⁾ For explosion-proof motors, the type of construction IM V1 without protective cover is not possible.
⁴⁾ The "Second shaft extension" option, order code **K16** is not possible.

IEC Squirrel-Cage Motors

Non-standard motors frame size 315 and above

Forced-air cooled motors with separately driven fan
for converter-fed operation – Cast-iron series 1PQ8

Selection and ordering data (continued)

Order No.	Breakdown torque at 50 Hz as multiple of rated torque	Torque class	Moment of inertia	Technical data of the separately driven fan				Measuring surface sound pressure level at 50 Hz	Sound power level at 50 Hz	Mech. limit speed ¹⁾	Parallel feeders required			
				Power consumption with	Rated current at	50 Hz	60 Hz				400 V	460 V	50 Hz	60 Hz
	T_B/T_{rated}	CL	J kgm ²	P kW	P kW	I A	I A	$L_{p(A)}$ dB(A)	L_{WA} dB(A)	$n_{max.}$ rpm	$f_{max.}$ Hz			
2-pole, 3000 rpm at 50 Hz, 3600 rpm at 60 Hz, temperature class 155 (F), used acc. to temperature class 155 (F), IP55 degree of protection, specially for operation on SINAMICS or SIMOVERT MASTERDRIVES with standard insulation for voltages ≤500 V														
1PQ8 315-2PC□□	2.8	10	2.7	0.75	1.23	3.4	3.3	79	94	3600	60		Yes	
1PQ8 317-2PC□□	2.8	10	3.3	0.75	1.23	3.4	3.3	79	94	3600	60		Yes	
1PQ8 353-2PC□□	2.5	10	4.8	1.3	2.2	6.4	6.2	81	96	3600/3100 ²⁾	60/52 ²⁾	Yes	Yes	
1PQ8 355-2PC□□	2.5	10	5.3	1.3	2.2	6.4	6.2	81	96	3600/3100 ²⁾	60/52 ²⁾	Yes	Yes	
1PQ8 357-2PC□□	2.6	10	6.4	1.3	2.2	6.4	6.2	81	96	3600/3100 ²⁾	60/52 ²⁾	Yes		
1PQ8 403-2PC□□	2.8	10	8.6	1.6	2.8	6.4	6.2	83	98	3600/3100 ²⁾	60/52 ²⁾	Yes		
1PQ8 405-2PC□□	2.8	10	9.6	1.6	2.8	6.4	6.2	83	98	3600/3100 ²⁾	60/52 ²⁾	Yes	Yes	
1PQ8 407-2PC□□	2.8	10	11	1.6	2.8	6.4	6.2	83	98	3600/3100 ²⁾	60/52 ²⁾		Yes	
1PQ8 453-2PE□□	3.0	5	19	3.0	4.2	8.2	7.7	86	101	3000	50		Yes	
1PQ8 455-2PE□□	2.8	5	21	3.0	4.2	8.2	7.7	86	101	3000	50		Yes	Yes
1PQ8 457-2PE□□	2.7	5	23	3.0	4.2	8.2	7.7	86	101	3000	50		Yes	Yes
4-pole, 1500 rpm at 50 Hz, 1800 rpm at 60 Hz, temperature class 155 (F), used acc. to temperature class 155 (F), IP55 degree of protection, specially for operation on SINAMICS or SIMOVERT MASTERDRIVES with standard insulation for voltages ≤500 V														
1PQ8 315-4PB□□	2.8	13	3.6	0.75	1.23	3.4	3.3	79	93	3000 (2650)	100 (88)	Yes		
1PQ8 317-4PB□□	2.8	13	4.4	0.75	1.23	3.4	3.3	79	93	3000 (2650)	100 (88)	Yes		
1PQ8 353-4PB□□	2.6	13	6.1	1.3	2.2	6.4	6.2	81	96	2500 (2350)	83 (78)	Yes	Yes	
1PQ8 355-4PB□□	2.6	13	6.8	1.3	2.2	6.4	6.2	81	96	2500 (2350)	83 (78)	Yes	Yes	
1PQ8 357-4PB□□	2.4	13	8.5	1.3	2.2	6.4	6.2	81	96	2500 (2350)	83 (78)	Yes		
1PQ8 403-4PB□□	2.7	13	13	1.6	2.8	6.4	6.2	83	98	2200 (2100)/2100 ²⁾	73 (70)/70 ²⁾	Yes		
1PQ8 405-4PB□□	2.7	13	14	1.6	2.8	6.4	6.2	83	98	2200 (2100)/2100 ²⁾	73 (70)/70 ²⁾	Yes	Yes	
1PQ8 407-4PB□□	2.7	13	16	1.6	2.8	6.4	6.2	83	98	2200 (2100)/2100 ²⁾	73 (70)/70 ²⁾	Yes		
1PQ8 453-4PC□□	2.6	10	23	3.0	4.2	8.2	7.7	86	101	2100 (1900)/1800 ²⁾	70 (63)/60 ²⁾	Yes		
1PQ8 455-4PC□□	2.6	10	26	3.0	4.2	8.2	7.7	86	101	2100 (1900)/1800 ²⁾	70 (63)/60 ²⁾	Yes	Yes	
1PQ8 457-4PC□□	2.6	10	28	3.0	4.2	8.2	7.7	86	101	2100 (1900)/1800 ²⁾	70 (63)/60 ²⁾	Yes	Yes	

Values in brackets apply to the use of motors in hazardous areas.

¹⁾ Limit speeds for reinforced bearings (order code **K20**) for 4-pole motors on request.

²⁾ For vertical type of construction IM V1.

IEC Squirrel-Cage Motors

Non-standard motors frame size 315 and above

Forced-air cooled motors with separately driven fan for converter-fed operation – Cast-iron series 1PQ8

Selection and ordering data (continued)

Rated output at		Frame size	Operating values at rated output and sinusoidal supply							Order No.	Price	Weight of IM B3 type of construction approx.
50 Hz	60 Hz		Rated speed at 50 Hz	Rated torque at 50 Hz	Efficiency at 50 Hz 4/4-load	Efficiency at 50 Hz 3/4-load	Power factor at 50 Hz 4/4-load	Rated current at 50 Hz 400 V	Rated current at 50 Hz 690 V			
P_{rated} kW	P_{rated} kW	FS	n_{rated} rpm	T_{rated} Nm	η_{rated} %	η_{rated} %	$\cos \varphi_{rated}$	I_{rated} A	I_{rated} A		m kg	
6-pole, 1000 rpm at 50 Hz, 1200 rpm at 60 Hz, temperature class 155 (F), used acc. to temperature class 155 (F), IP55 degree of protection, specially for operation on SINAMICS or SIMOVERT MASTERDRIVES with standard insulation for voltages ≤500 V												
200	230	315	988	1930	95.7	95.8	0.86	345	200	1PQ8 315-6PB□□	1400	
250	288	315	988	2410	95.9	96.0	0.86	430	250	1PQ8 317-6PB□□	1600	
315	362	355	993	3040	96.2	96.2	0.86	540	315	1PQ8 355-6PB□□	2100	
400	460	355	993	3850	96.5	96.5	0.86	690	400	1PQ8 357-6PB□□	2300	
450	518	400	991	4330	96.5	96.5	0.86	780	455	1PQ8 403-6PB□□	2900	
500	575	400	991	4810	96.5	96.5	0.86	860	500	1PQ8 405-6PB□□	3100	
560	644	400	991	5390	96.7	96.7	0.86	960	460	1PQ8 407-6PB□□	3300	
630	725	450	993	6060	96.8	96.8	0.86	1100	630	1PQ8 453-6PB□□	4100	
710	817	450	993	6830	96.8	96.8	0.86	–	710 ¹⁾	1PQ8 455-6PB□□	4300	
800	920	450	993	7690	97.0	97.1	0.86	–	790 ¹⁾	1PQ8 457-6PB□□	4600	
8-pole, 750 rpm at 50 Hz, 900 rpm at 60 Hz, temperature class 155 (F), used acc. to temperature class 155 (F), IP55 degree of protection, specially for operation on SINAMICS or SIMOVERT MASTERDRIVES with standard insulation for voltages ≤500 V												
160	184	315	739	2070	94.9	94.9	0.82	295	172	1PQ8 315-8PB□□	1400	
200	230	315	739	2580	95.2	95.2	0.82	370	215	1PQ8 317-8PB□□	1600	
250	288	355	741	3220	95.7	95.7	0.82	460	265	1PQ8 355-8PB□□	2100	
315	362	355	741	4060	96.0	96.0	0.82	580	335	1PQ8 357-8PB□□	2300	
355	408	400	742	4570	96.1	96.1	0.82	650	375	1PQ8 403-8PB□□	2900	
400	460	400	742	5150	96.2	96.2	0.82	730	425	1PQ8 405-8PB□□	3100	
450	518	400	742	5790	96.3	96.3	0.82	820	475	1PQ8 407-8PB□□	3300	
500	575	450	744	6420	96.4	96.4	0.81	920	540	1PQ8 453-8PB□□	4100	
560	644	450	744	7190	96.5	96.5	0.81	1040	600	1PQ8 455-8PB□□	4300	
630	725	450	744	8090	96.6	96.6	0.81	1160	670	1PQ8 457-8PB□□	4600	

Order No. supplements

Motor type	Penultimate position: Voltage code				Final position: Type of construction code			
	400 VΔ	400 VΔ/690 VY ²⁾	500 VΔ	690 VΔ ²⁾	Without flange IM B3	With flange IM V1 without protective cover ³⁾	IM V1 with protective cover ⁴⁾	IM B35
	4	8	5	7	0	8	4	6
6-pole								
1PQ8 315-... □□ to 1PQ8 453-... □□	○	□	○	–	□	✓	✓	✓
1PQ8 455-... □□ to 1PQ8 457-... □□	–	–	○	□	□	✓	✓	✓
8-pole								
1PQ8 315-... □□ to 1PQ8 457-... □□	○	□	○	– ⁵⁾	□	✓	✓	✓

- Standard version
- Without additional charge
- ✓ With additional charge
- Not possible

Order other voltages with voltage code **9** in the penultimate position and the corresponding order code (see "Special versions" in the "Selection and ordering data" under "Voltages").

Voltages or frequencies that are not covered by the predefined options can be ordered with order code **L1Y**. In this case, the output, voltage and frequency must be specified.

- 1) Can also be supplied for 400 VΔ 50 Hz with voltage code **9** and order code **L1Y** (specify output, voltage and frequency).
- 2) Motors with standard insulation can only be operated with converter circuit (du/dt or sinusoidal filter).
- 3) For explosion-proof motors, the type of construction IM V1 without protective cover is not possible.

- 4) The "Second shaft extension" option, order code **K16** is not possible.
- 5) As special version with voltage code **9** and order code **L1Y** (specify output, voltage and frequency).

IEC Squirrel-Cage Motors

Non-standard motors frame size 315 and above

Forced-air cooled motors with separately driven fan
for converter-fed operation – Cast-iron series 1PQ8

Selection and ordering data (continued)

Order No.	Breakdown torque at 50 Hz as multiple of rated torque	Torque class	Moment of inertia	Technical data of the separately driven fan				Measuring surface sound pressure level at 50 Hz	Sound power level at 50 Hz	Mech. limit speed ¹⁾	Parallel feeders required			
				Power consumption with		Rated current at					For rated output, 50 Hz, tolerance +3 dB(A)	400 V 500 V 690 V	400 V	500 V
T_B/T_{rated}	CL	J kgm ²	P kW	P kW	I A	I A	L_{pA} dB(A)	L_{WA} dB(A)	$n_{max.}$ rpm	$f_{max.}$ Hz				
6-pole, 1000 rpm at 50 Hz, 1200 rpm at 60 Hz, temperature class 155 (F), used acc. to temperature class 155 (F), IP55 degree of protection, specially for operation on SINAMICS or SIMOVERT MASTERDRIVES with standard insulation for voltages ≤500 V														
1PQ8 315-6PB□□	2.5	13	6.0	0.75	1.23	3.4	3.3	80	94	2950 (2350)	147 (117)			
1PQ8 317-6PB□□	2.5	13	7.3	0.75	1.23	3.4	3.3	80	94	2950 (2350)	147 (117)	Yes		
1PQ8 355-6PB□□	2.8	13	13	1.3	2.2	6.4	6.2	82	97	2500 (2100)	125 (105)	Yes		
1PQ8 357-6PB□□	2.8	13	16	1.3	2.2	6.4	6.2	82	97	2500 (2100)	125 (105)	Yes	Yes	
1PQ8 403-6PB□□	2.8	13	21	1.3	2.2	6.4	6.2	84	99	2200 (1900)/2100 ²⁾	110 (95)/105 ²⁾			
1PQ8 405-6PB□□	2.8	13	24	1.6	2.8	6.4	6.2	84	99	2200 (1900)/2100 ²⁾	110 (95)/105 ²⁾	Yes		
1PQ8 407-6PB□□	2.8	13	27	1.6	2.8	6.4	6.2	84	99	2200 (1900)/2100 ²⁾	110 (95)/105 ²⁾	Yes		
1PQ8 453-6PB□□	2.6	13	35	3.0	4.2	8.2	7.7	87	102	2100 (1700)/1800 ²⁾	105 (85)/90 ²⁾	Yes	Yes	
1PQ8 455-6PB□□	2.5	13	39	3.0	4.2	8.2	7.7	87	102	2100 (1700)/1800 ²⁾	105 (85)/90 ²⁾		Yes	
1PQ8 457-6PB□□	2.5	13	44	3.0	4.2	8.2	7.7	87	102	2100 (1700)/1800 ²⁾	105 (85)/90 ²⁾		Yes	
8-pole, 750 rpm at 50 Hz, 900 rpm at 60 Hz, temperature class 155 (F), used acc. to temperature class 155 (F), IP55 degree of protection, specially for operation on SINAMICS or SIMOVERT MASTERDRIVES with standard insulation for voltages ≤500 V														
1PQ8 315-8PB□□	2.3	13	6.0	0.75	1.23	3.4	3.3	79	93	2950 (2350)	196 (156)			
1PQ8 317-8PB□□	2.3	13	7.3	0.75	1.23	3.4	3.3	79	93	2950 (2350)	196 (156)			
1PQ8 355-8PB□□	2.4	13	13	1.3	2.2	6.4	6.2	81	96	2500 (2100)	166 (140)			
1PQ8 357-8PB□□	2.4	13	16	1.3	2.2	6.4	6.2	81	96	2500 (2100)	166 (140)	Yes		
1PQ8 403-8PB□□	2.6	13	21	1.3	2.2	6.4	6.2	83	98	2200 (1900)/2100 ²⁾	146 (126)/140 ²⁾			
1PQ8 405-8PB□□	2.6	13	24	1.6	2.8	6.4	6.2	83	98	2200 (1900)/2100 ²⁾	146 (126)/140 ²⁾			
1PQ8 407-8PB□□	2.6	13	27	1.6	2.8	6.4	6.2	83	98	2200 (1900)/2100 ²⁾	146 (126)/140 ²⁾	Yes		
1PQ8 453-8PB□□	2.4	13	35	3.0	4.2	8.2	7.7	86	101	2100 (1700)/1800 ²⁾	140 (113)/120 ²⁾	Yes		
1PQ8 455-8PB□□	2.4	13	39	3.0	4.2	8.2	7.7	86	101	2100 (1700)/1800 ²⁾	141 (113)/120 ²⁾	Yes	Yes	
1PQ8 457-8PB□□	2.4	13	44	3.0	4.2	8.2	7.7	86	101	2100 (1700)/1800 ²⁾	142 (113)/120 ²⁾	Yes	Yes	

Values in brackets apply to the use of motors in hazardous areas.

¹⁾ Limit speeds for reinforced bearings (order code **K20**) for 6- and 8-pole motors on request.

²⁾ For vertical type of construction IM V1.

IEC Squirrel-Cage Motors

Non-standard motors frame size 315 and above

Forced-air cooled motors with separately driven fan for converter-fed operation – Cast-iron series 1PQ8

Selection and ordering data (continued)

Rated output at		Frame size	Operating values at rated output and sinusoidal supply						Order No.	Price	Weight of IM B3 type of construction approx.
50 Hz	60 Hz		Rated speed at 50 Hz	Rated torque at 50 Hz	Efficiency at 50 Hz 4/4-load	Efficiency at 50 Hz 3/4-load	Power factor at 50 Hz 4/4-load	Rated current at 50 Hz 690 V			
P_{rated} kW	P_{rated} kW	FS	n_{rated} rpm	T_{rated} Nm	η_{rated} %	η_{rated} %	$\cos\phi_{rated}$	I_{rated} A		m kg	
2-pole, 3000 rpm at 50 Hz, 3600 rpm at 60 Hz, temperature class 155 (F), used acc. to temperature class 155 (F), IP55 degree of protection, specially for operation on SINAMICS or SIMOVERT MASTERDRIVES with special insulation for voltages >500 to 690 V											
240	270	315	2978	770	96.0	96.0	0.90	230	1PQ8 315-2PM8□	1400	
300	335	315	2978	962	96.4	96.4	0.91	285	1PQ8 317-2PM8□	1600	
345	385	355	2981	1105	96.4	96.4	0.90	335	1PQ8 353-2PM8□	2000	
390	435	355	2981	1249	96.6	96.6	0.91	370	1PQ8 355-2PM8□	2100	
485	545	355	2982	1553	97.0	97.0	0.91	460	1PQ8 357-2PM8□	2300	
545	600	400	2986	1743	97.1	97.1	0.91	520	1PQ8 403-2PM7□	2900	
610	670	400	2986	1951	97.1	97.1	0.91	580	1PQ8 405-2PM7□	3100	
680	750	400	2986	2175	97.2	97.2	0.92	640	1PQ8 407-2PM7□	3300	
775	-	450	2987	2478	97.2	97.2	0.92	730	1PQ8 453-2PM7□	4100	
875	-	450	2987	2798	97.3	97.3	0.92	820	1PQ8 455-2PM7□	4300	
970	-	450	2987	3101	97.4	97.4	0.93	900	1PQ8 457-2PM7□	4500	
4-pole, 1500 rpm at 50 Hz, 1800 rpm at 60 Hz, temperature class 155 (F), used acc. to temperature class 155 (F), IP55 degree of protection, specially for operation on SINAMICS or SIMOVERT MASTERDRIVES with special insulation for voltages >500 to 690 V											
235	270	315	1485	1511	95.8	95.8	0.87	235	1PQ8 315-4PM8□	1400	
290	335	315	1485	1865	95.9	95.9	0.87	285	1PQ8 317-4PM8□	1600	
340	390	355	1488	2182	96.0	96.0	0.87	340	1PQ8 353-4PM8□	2000	
385	445	355	1488	2471	96.2	96.2	0.87	385	1PQ8 355-4PM8□	2100	
480	550	355	1488	3081	96.4	96.4	0.87	480	1PQ8 357-4PM8□	2300	
545	625	400	1491	3491	96.5	96.5	0.88	540	1PQ8 403-4PM8□	2900	
615	710	400	1491	3939	96.7	96.7	0.88	600	1PQ8 405-4PM8□	3100	
690	795	400	1491	4420	96.9	96.9	0.89	670	1PQ8 407-4PM7□	3300	
785	905	450	1492	5025	96.8	96.8	0.88	770	1PQ8 453-4PM7□	4100	
880	1010	450	1492	5633	97.0	97.0	0.87	870	1PQ8 455-4PM7□	4300	
980	1125	450	1492	6273	97.1	97.1	0.89	950	1PQ8 457-4PM7□	4500	

Order No. supplements

Motor type	Final position: Type of construction code			
	Without flange IM B3	With flange		
		IM V1 without protective cover	IM V1 with protective cover	IM B35
	0	8	4	6
1PQ8 315- . . . □□ to 1PQ8 457- . . . □□	□	✓	✓	✓

- Standard version
- ✓ With additional charge

The voltage code is already in the Order No. as the penultimate position.

Assignment:

7 = 690 VΔ

8 = 400 VΔ/690 VY

Order other voltages with voltage code **9** in the penultimate position and the corresponding order code (see "Special versions" in the "Selection and ordering data" under "Voltages").

Voltages or frequencies that are not covered by the predefined options can be ordered with order code **L1Y**. In this case, the output, voltage and frequency must be specified.

IEC Squirrel-Cage Motors

Non-standard motors frame size 315 and above

Forced-air cooled motors with separately driven fan
for converter-fed operation – Cast-iron series 1PQ8

Selection and ordering data (continued)

Order No.	Breakdown torque at 50 Hz as multiple of rated torque	Torque class	Moment of inertia	Technical data of the separately driven fan				Measuring surface sound pressure level at 50 Hz	Sound power level at 50 Hz	Mech. limit speed ¹⁾	Parallel feeders required			
				Power consumption with	Rated current at	50 Hz	60 Hz						400 V	460 V
	T_B/T_{rated}	CL	J kgm ²	P kW	P kW	I A	I A	$L_{p(A)}$ dB(A)	L_{WA} dB(A)	$n_{max.}$ rpm	$f_{max.}$ Hz	400 V	500 V	690 V
2-pole, 3000 rpm at 50 Hz, 3600 rpm at 60 Hz, temperature class 155 (F), used acc. to temperature class 155 (F), IP55 degree of protection, specially for operation on SINAMICS or SIMOVERT MASTERDRIVES with special insulation for voltages >500 to 690 V														
1PQ8 315-2PM8□	3.0	10	2.7	0.75	1.23	3.4	3.3	79	94	3600	60	Yes	Yes	
1PQ8 317-2PM8□	3.0	10	3.3	0.75	1.23	3.4	3.3	79		3600	60	Yes	Yes	
1PQ8 353-2PM8□	2.6	10	4.8	1.3	2.2	6.4	6.2	81	96	3600/3100 ²⁾	60/52 ²⁾	Yes	Yes	
1PQ8 355-2PM8□	2.6	10	5.3	1.3	2.2	6.4	6.2	81		3600/3100 ²⁾	60/52 ²⁾	Yes	Yes	
1PQ8 357-2PM8□	2.6	10	6.4	1.3	2.2	6.4	6.2	81		3600/3100 ²⁾	60/52 ²⁾	Yes		
1PQ8 403-2PM7□	3.0	10	8.6	1.6	2.8	6.4	6.2	83	98	3600/3100 ²⁾	60/52 ²⁾	Yes		
1PQ8 405-2PM7□	3.1	10	9.6	1.6	2.8	6.4	6.2	83		3600/3100 ²⁾	60/52 ²⁾	Yes	Yes	
1PQ8 407-2PM7□	3.0	10	11	1.6	2.8	6.4	6.2	83		3600/3100 ²⁾	60/52 ²⁾	Yes		
1PQ8 453-2PM7□	2.8	5	19	3.0	4.2	8.2	7.7	86	101	3000	50	Yes		
1PQ8 455-2PM7□	2.8	5	21	3.0	4.2	8.2	7.7	86		3000	50	Yes	Yes	
1PQ8 457-2PM7□	2.8	5	23	3.0	4.2	8.2	7.7	86		3000	50	Yes	Yes	
4-pole, 1500 rpm at 50 Hz, 1800 rpm at 60 Hz, temperature class 155 (F), used acc. to temperature class 155 (F), IP55 degree of protection, specially for operation on SINAMICS or SIMOVERT MASTERDRIVES with special insulation for voltages >500 to 690 V														
1PQ8 315-4PM8□	2.8	13	3.6	0.75	1.23	3.4	3.3	79	93	3000 (2650)	100 (88)	Yes		
1PQ8 317-4PM8□	2.8	13	4.4	0.75	1.23	3.4	3.3	79		3000 (2650)	100 (88)	Yes		
1PQ8 353-4PM8□	2.6	13	6.1	1.3	2.2	6.4	6.2	81	96	2500 (2350)	83 (78)	Yes	Yes	
1PQ8 355-4PM8□	2.6	13	6.8	1.3	2.2	6.4	6.2	81		2500 (2350)	83 (78)	Yes	Yes	
1PQ8 357-4PM8□	2.5	13	8.5	1.3	2.2	6.4	6.2	81		2500 (2350)	83 (78)	Yes		
1PQ8 403-4PM8□	2.6	13	13	1.6	2.8	6.4	6.2	83	98	2200 (2100)/2100 ²⁾	73 (70)/70 ²⁾	Yes		
1PQ8 405-4PM8□	2.7	13	14	1.6	2.8	6.4	6.2	83		2200 (2100)/2100 ²⁾	73 (70)/70 ²⁾	Yes	Yes	
1PQ8 407-4PM7□	2.6	13	16	1.6	2.8	6.4	6.2	83		2200 (2100)/2100 ²⁾	73 (70)/70 ²⁾	Yes		
1PQ8 453-4PM7□	2.5	10	23	3.0	4.2	8.2	7.7	86	101	2100 (1900)/1800 ²⁾	70 (61)/60 ²⁾	Yes		
1PQ8 455-4PM7□	2.6	10	26	3.0	4.2	8.2	7.7	86		2100 (1900)/1800 ²⁾	70 (61)/60 ²⁾	Yes	Yes	
1PQ8 457-4PM7□	2.6	10	28	3.0	4.2	8.2	7.7	86		2100 (1900)/1800 ²⁾	70 (61)/60 ²⁾	Yes	Yes	

Values in brackets apply to the use of motors in hazardous areas.

¹⁾ Limit speeds for reinforced bearings (order code **K20**) for 4-pole motors on request.

²⁾ For vertical type of construction IM V1.

IEC Squirrel-Cage Motors

Non-standard motors frame size 315 and above

Forced-air cooled motors with separately driven fan
for converter-fed operation – Cast-iron series 1PQ8

Selection and ordering data (continued)

Rated output at		Frame size	Operating values at rated output and sinusoidal supply						Order No.	Price	Weight of IM B3 type of construction approx.
50 Hz	60 Hz		Rated speed at 50 Hz	Rated torque at 50 Hz	Efficiency at 50 Hz 4/4-load	Efficiency at 50 Hz 3/4-load	Power factor at 50 Hz 4/4-load	Rated current at 50 Hz 690 V			
P_{rated} kW	P_{rated} kW	FS	n_{rated} rpm	T_{rated} Nm	η_{rated} %	η_{rated} %	$\cos\phi_{rated}$	I_{rated} A		m kg	
6-pole, 1000 rpm at 50 Hz, 1200 rpm at 60 Hz, temperature class 155 (F), used acc. to temperature class 155 (F), IP55 degree of protection, specially for operation on SINAMICS or SIMOVERT MASTERDRIVES with special insulation for voltages >500 to 690 V											
190	220	315	990	1833	95.5	95.6	0.85	196	1PQ8 315-6PM8□	1400	
235	270	315	990	2267	95.7	95.8	0.86	240	1PQ8 317-6PM8□	1600	
300	345	355	992	2888	96.2	96.2	0.86	305	1PQ8 355-6PM8□	2100	
380	435	355	992	3658	96.4	96.4	0.86	385	1PQ8 357-6PM8□	2300	
435	500	400	993	4184	96.4	96.4	0.85	445	1PQ8 403-6PM8□	2900	
485	560	400	993	4664	96.5	96.5	0.86	490	1PQ8 405-6PM8□	3100	
545	625	400	993	5241	96.6	96.6	0.86	550	1PQ8 407-6PM8□	3300	
615	705	450	993	5915	96.8	96.8	0.84	630	1PQ8 453-6PM8□	4100	
690	795	450	993	6636	96.8	96.8	0.85	700	1PQ8 455-6PM7□	4300	
780	895	450	993	7502	96.9	97.0	0.85	790	1PQ8 457-6PM7□	4600	
8-pole, 750 rpm at 50 Hz, 900 rpm at 60 Hz, temperature class 155 (F), used acc. to temperature class 155 (F), IP55 degree of protection, specially for operation on SINAMICS or SIMOVERT MASTERDRIVES with special insulation for voltages >500 to 690 V											
145	165	315	740	1871	94.6	94.6	0.79	162	1PQ8 315-8PM8□	1400	
180	205	315	740	2323	94.9	94.9	0.80	198	1PQ8 317-8PM8□	1600	
230	265	355	743	2956	95.5	95.5	0.80	250	1PQ8 355-8PM8□	2100	
290	335	355	743	3727	95.7	95.7	0.81	315	1PQ8 357-8PM8□	2300	
335	385	400	743	4306	96.0	96.0	0.80	365	1PQ8 403-8PM8□	2900	
375	430	400	743	4820	96.1	96.1	0.80	410	1PQ8 405-8PM8□	3100	
425	490	400	743	5463	96.2	96.2	0.79	470	1PQ8 407-8PM8□	3300	
485	560	450	745	6217	96.5	96.5	0.78	540	1PQ8 453-8PM8□	4100	
545	625	450	745	6986	96.6	96.6	0.78	610	1PQ8 455-8PM8□	4300	
600	690	450	745	7691	96.7	96.7	0.79	660	1PQ8 457-8PM8□	4600	

Order No. supplements

Motor type	Final position: Type of construction code			
	Without flange	With flange		
	IM B3	IM V1 without protective cover	IM V1 with protective cover	IM B35
	0	8	4	6
1PQ8 315-... □□ to 1PQ8 457-... □□	□	✓	✓	✓

- Standard version
- ✓ With additional charge

The voltage code is already in the Order No. as the penultimate position.

Assignment:

7 = 690 VΔ

8 = 400 VΔ/690 VY

Order other voltages with voltage code **9** in the penultimate position and the corresponding order code (see "Special versions" in the "Selection and ordering data" under "Voltages").

Voltages or frequencies that are not covered by the predefined options can be ordered with order code **L1Y**. In this case, the output, voltage and frequency must be specified.

IEC Squirrel-Cage Motors

Non-standard motors frame size 315 and above

Forced-air cooled motors with separately driven fan
for converter-fed operation – Cast-iron series 1PQ8

Selection and ordering data (continued)

Order No.	Breakdown torque at 50 Hz as multiple of rated torque	Torque class	Moment of inertia	Technical data of the separately driven fan				Measuring surface sound pressure level at 50 Hz	Sound power level at 50 Hz	Mech. limit speed ¹⁾			Parallel feeders required	
				Power consumption with	Rated current at		For rated output, 50 Hz, tolerance +3 dB(A)			400 V 50 Hz	460 V 60 Hz	690 V		
	T_B/T_{rated}	CL	J kgm ²	P kW	P kW	I A	I A	L_{pfA} dB(A)	L_{WA} dB(A)	$n_{max.}$ rpm	$f_{max.}$ Hz	400 V	500 V	690 V
6-pole, 1000 rpm at 50 Hz, 1200 rpm at 60 Hz, temperature class 155 (F), used acc. to temperature class 155 (F), IP55 degree of protection, specially for operation on SINAMICS or SIMOVERT MASTERDRIVES with special insulation for voltages >500 to 690 V														
1PQ8 315-6PM8□	2.7	13	6	0.75	1.23	3.4	3.3	80	94	2950 (2350)	147 (117)			
1PQ8 317-6PM8□	2.7	13	7.3	0.75	1.23	3.4	3.3	80	94	2950 (2350)	147 (117)	Yes		
1PQ8 355-6PM8□	2.8	13	13	1.3	2.2	6.4	6.2	82	97	2500 (2100)	125 (105)	Yes		
1PQ8 357-6PM8□	2.9	13	16	1.3	2.2	6.4	6.2	82	97	2500 (2100)	125 (105)	Yes	Yes	
1PQ8 403-6PM8□	2.8	13	21	1.3	2.2	6.4	6.2	84	99	2200 (1900)/2100 ²⁾	110 (95)/105 ²⁾			
1PQ8 405-6PM8□	2.8	13	24	1.6	2.8	6.4	6.2	84	99	2200 (1900)/2100 ²⁾	110 (95)/105 ²⁾	Yes		
1PQ8 407-6PM8□	2.7	13	27	1.6	2.8	6.4	6.2	84	99	2200 (1900)/2100 ²⁾	110 (95)/105 ²⁾	Yes		
1PQ8 453-6PM8□	2.7	13	35	1.6	2.8	6.4	6.2	87	102	2100 (1700)/1800 ²⁾	105 (85)/90 ²⁾	Yes	Yes	
1PQ8 455-6PM7□	2.5	13	39	3	4.2	8.2	7.7	87	102	2100 (1700)/1800 ²⁾	105 (85)/90 ²⁾			Yes
1PQ8 457-6PM7□	2.6	13	44	3	4.2	8.2	7.7	87	102	2100 (1700)/1800 ²⁾	105 (85)/90 ²⁾			Yes
8-pole, 750 rpm at 50 Hz, 900 rpm at 60 Hz, temperature class 155 (F), used acc. to temperature class 155 (F), IP55 degree of protection, specially for operation on SINAMICS or SIMOVERT MASTERDRIVES with special insulation for voltages >500 to 690 V														
1PQ8 315-8PM8□	2.5	13	6	0.75	1.23	3.4	3.3	79	93	2950 (2350)	196 (156)			
1PQ8 317-8PM8□	2.5	13	7.3	0.75	1.23	3.4	3.3	79	93	2950 (2350)	196 (156)			
1PQ8 355-8PM8□	2.4	13	13	1.3	2.2	6.4	6.2	81	96	2500 (2100)	166 (140)			
1PQ8 357-8PM8□	2.4	13	16	1.3	2.2	6.4	6.2	81	96	2500 (2100)	166 (140)			Yes
1PQ8 403-8PM8□	2.6	13	21	1.3	2.2	6.4	6.2	83	98	2200 (1900)/2100 ²⁾	146 (126)/140 ²⁾			
1PQ8 405-8PM8□	2.7	13	24	1.6	2.8	6.4	6.2	83	98	2200 (1900)/2100 ²⁾	146 (126)/140 ²⁾			
1PQ8 407-8PM8□	2.7	13	27	1.6	2.8	6.4	6.2	83	98	2200 (1900)/2100 ²⁾	146 (126)/140 ²⁾	Yes		
1PQ8 453-8PM8□	2.5	13	35	1.6	2.8	6.4	6.2	86	101	2100 (1700)/1800 ²⁾	140 (113)/120 ²⁾	Yes		
1PQ8 455-8PM8□	2.5	13	39	3	4.2	8.2	7.7	86	101	2100 (1700)/1800 ²⁾	140 (113)/120 ²⁾	Yes	Yes	
1PQ8 457-8PM8□	2.5	13	44	3	4.2	8.2	7.7	86	101	2100 (1700)/1800 ²⁾	140 (113)/120 ²⁾	Yes	Yes	

Values in brackets apply to the use of motors in hazardous areas.

¹⁾ Limit speeds for reinforced bearings (order code **K20**) for 6- and 8-pole motors on request.

²⁾ For vertical type of construction IM V1.

IEC Squirrel-Cage Motors

Non-standard motors frame size 315 and above

Self-ventilated motors with through ventilation
for mains-fed operation – Cast-iron series 1LL8

Selection and ordering data

Rated output at		Frame size	Operating values at rated output						Order No.	Price	Weight of IM B3 type of construction approx.
50 Hz	60 Hz		Rated speed at 50 Hz	Rated torque at 50 Hz	Efficiency at 50 Hz 4/4-load	Power factor at 50 Hz 4/4-load	Rated current at 50 Hz 400 V	Rated current at 50 Hz 690 V			
P_{rated} kW	P_{rated} kW	FS	n_{rated} rpm	T_{rated} Nm	η_{rated} %	$\cos\phi_{rated}$	I_{rated} A	I_{rated} A		m kg	
2-pole, 3000 rpm at 50 Hz, 3600 rpm at 60 Hz, temperature class 155 (F), used acc. to temperature class 130 (B), IP23 degree of protection											
315	345	315	2974	1010	96.1	0.92	510	300	1LL8 315-2AC□□	1300	
400	440	315	2974	1280	96.4	0.92	650	375	1LL8 317-2AC□□	1500	
450	–	355	2978	1440	96.4	0.91	740	430	1LL8 353-2AD□□	1900	
500	–	355	2979	1600	96.6	0.92	810	470	1LL8 355-2AD□□	2000	
630	–	355	2980	2020	96.9	0.93	1000	580	1LL8 357-2AD□□	2200	
710	–	400	2984	2270	97.0	0.91	1160	670	1LL8 403-2AD□□	2800	
800	–	400	2984	2560	97.1	0.92	1300	750	1LL8 405-2AD□□	3000	
900	–	400	2985	2880	97.3	0.92	–	840	1LL8 407-2AD□□	3200	
1000	–	450	2987	3200	97.3	0.93	–	920	1LL8 453-2AE□□	4000	
1120	–	450	2986	3580	97.3	0.94	–	1020	1LL8 455-2AE□□	4200	
1250	–	450	2986	4000	97.4	0.94	–	1140	1LL8 457-2AE□□	4400	
4-pole, 1500 rpm at 50 Hz, 1800 rpm at 60 Hz, temperature class 155 (F), used acc. to temperature class 130 (B), IP23 degree of protection											
315	360	315	1483	2030	96.0	0.87	540	315	1LL8 315-4AC□□	1300	
400	460	315	1484	2570	96.2	0.88	680	395	1LL8 317-4AC□□	1500	
450	515	355	1487	2890	96.5	0.87	770	450	1LL8 353-4AC□□	1900	
500	575	355	1487	3210	96.6	0.88	850	490	1LL8 355-4AC□□	2000	
630	725	355	1488	4040	96.9	0.88	1060	620	1LL8 357-4AC□□	2200	
710	815	400	1489	4550	96.9	0.88	1200	700	1LL8 403-4AC□□	2800	
800	920	400	1490	5130	97.0	0.88	–	780	1LL8 405-4AC□□	3000	
900	1035	400	1491	5760	97.2	0.87	–	890	1LL8 407-4AC□□	3200	
1000	1150	450	1492	6400	97.2	0.86	–	1000	1LL8 453-4AD□□	4000	
1120	1280	450	1491	7170	97.2	0.89	–	1080	1LL8 455-4AD□□	4200	
1250	1430	450	1490	8010	97.2	0.89	–	1200	1LL8 457-4AD□□	4400	

A service factor (SF) of 1.05 is stamped onto all 1LL8 motors for mains-fed operation.

Order No. supplements

Motor type	Penultimate position: Voltage code				Final position: Type of construction code			
	400 VΔ/690 VY	500 VΔ	690 VΔ	60 Hz 460 VΔ (see "Introduction" for outputs at 60 Hz)	Without flange IM B3	With flange		IM B35
					IM V1 without protective cover	IM V1 with protective cover ¹⁾		
	6	5	0	9 L2F	0	8	4	6
1LL8 315-...□□ to 1LL8 317-...□□	□	○	– ²⁾	○	□	✓	✓	✓
1LL8 353-...□□ to 1LL8 405-...□□	□	○	– ²⁾	○	□ ³⁾	✓ ³⁾	✓ ³⁾	✓ ³⁾
1LL8 407-...□□ to 1LL8 457-...□□	–	○	□	O. R.	□ ³⁾	✓ ³⁾	✓ ³⁾	✓ ³⁾

- Standard version
- Without additional charge
- ✓ With additional charge
- O. R. Possible on request
- Not possible

Order other voltages with voltage code **9** in the penultimate position and the corresponding order code (see "Special versions" in the "Selection and ordering data" under "Voltages").

Voltages or frequencies that are not covered by the predefined options can be ordered with order code **L1Y**. In this case, the output, voltage and frequency must be specified.

- 1) The "Second shaft extension" option, order code **K16** is not possible.
- 2) As special version with voltage code **9** and order code **L1Y** (specify output, voltage and frequency).
- 3) Not possible for 2-pole motors in 60 Hz version.

IEC Squirrel-Cage Motors

Non-standard motors frame size 315 and above

Self-ventilated motors with through ventilation
for mains-fed operation – Cast-iron series 1LL8

Selection and ordering data (continued)

Order No.	Locked-rotor torque	Locked-rotor current	Break-down torque	Torque class	Moment of inertia	Noise at rated output		Mech. limit speed	Parallel feeders required		
	At 50 Hz and for direct online starting as multiple of rated torque	At 50 Hz and for direct online starting as multiple of rated current	At 50 Hz and for direct online starting as multiple of rated torque	CL	J kgm ²	Measuring surface sound pressure level at 50 Hz	Sound power level at 50 Hz		η_{\max} rpm	400 V	500 V
	T_{LR}/T_{rated}	I_{LR}/I_{rated}	T_B/T_{rated}			L_{pA} dB(A)	L_{WA} dB(A)				
2-pole, 3000 rpm at 50 Hz, 3600 rpm at 60 Hz, temperature class 155 (F), used acc. to temperature class 130 (B), IP23 degree of protection											
1LL8 315-2AC□□	1.6	7.0	2.8	10	2.7	84 ¹⁾	99	3600	Yes		
1LL8 317-2AC□□	1.7	7.0	2.8	10	3.3	84 ¹⁾	99	3600	Yes		
1LL8 353-2AD□□	1.4	7.0	2.6	7	4.8	86 ¹⁾	101	3600/3100 ²⁾	Yes	Yes	
1LL8 355-2AD□□	1.4	7.0	2.6	7	5.3	86 ¹⁾	101	3600/3100 ²⁾	Yes	Yes	
1LL8 357-2AD□□	1.6	7.0	2.6	7	6.4	86 ¹⁾	101	3600/3100 ²⁾	Yes		
1LL8 403-2AD□□	1.4	6.8	2.6	7	8.6	88 ¹⁾	103	3600/3100 ²⁾	Yes		
1LL8 405-2AD□□	1.5	7.0	2.6	7	9.6	88 ¹⁾	103	3600/3100 ²⁾	Yes	Yes	
1LL8 407-2AD□□	1.5	7.0	2.7	7	11	88 ¹⁾	103	3600/3100 ²⁾	Yes		
1LL8 453-2AE□□	0.9	7.0	2.9	5	19	90 ¹⁾	105	3000	Yes		
1LL8 455-2AE□□	0.9	7.0	2.7	5	21	90 ¹⁾	105	3000	Yes	Yes	
1LL8 457-2AE□□	0.9	7.0	2.6	5	23	90 ¹⁾	105	3000	Yes	Yes	
4-pole, 1500 rpm at 50 Hz, 1800 rpm at 60 Hz, temperature class 155 (F), used acc. to temperature class 130 (B), IP23 degree of protection											
1LL8 315-4AC□□	1.6	7.0	2.7	10	3.6	75	90	3000/2600 ²⁾	Yes		
1LL8 317-4AC□□	1.7	7.0	2.7	10	4.4	75	90	3000/2600 ²⁾	Yes		
1LL8 353-4AC□□	1.5	7.0	2.6	10	6.1	77	92	2500/2200 ²⁾	Yes	Yes	
1LL8 355-4AC□□	1.6	7.0	2.6	10	6.8	77	92	2500/2200 ²⁾	Yes	Yes	
1LL8 357-4AC□□	1.6	7.0	2.7	10	8.5	77	92	2500/2200 ²⁾	Yes		
1LL8 403-4AC□□	1.6	7.0	2.4	10	13	81	96	2200/1900 ²⁾	Yes		
1LL8 405-4AC□□	1.7	7.0	2.5	10	14	81	96	2200/1900 ²⁾	Yes	Yes	
1LL8 407-4AC□□	1.7	7.0	2.6	10	16	81	96	2200/1900 ²⁾	Yes		
1LL8 453-4AD□□	1.5	7.0	2.8	7	23	84	99	2100/1800 ²⁾	Yes		
1LL8 455-4AD□□	1.5	7.0	2.6	7	26	84	99	2100/1800 ²⁾	Yes	Yes	
1LL8 457-4AD□□	1.5	7.0	2.5	7	28	84	99	2100/1800 ²⁾	Yes	Yes	

¹⁾ The noise values for **1LL8**, 2-pole are for guidance only.

²⁾ For vertical type of construction IM V1.

IEC Squirrel-Cage Motors

Non-standard motors frame size 315 and above

Self-ventilated motors with through ventilation
for mains-fed operation – Cast-iron series 1LL8

Selection and ordering data (continued)

Rated output at		Frame size	Operating values at rated output						Order No.	Price	Weight of IM B3 type of construction approx.
50 Hz	60 Hz		Rated speed at 50 Hz	Rated torque at 50 Hz	Efficiency at 50 Hz 4/4-load	Power factor at 50 Hz 4/4-load	Rated current at 50 Hz 400 V	Rated current at 50 Hz 690 V			
P_{rated} kW	P_{rated} kW	FS	n_{rated} rpm	T_{rated} Nm	η_{rated} %	$\cos\phi_{rated}$	I_{rated} A	I_{rated} A		m kg	
6-pole, 1000 rpm at 50 Hz, 1200 rpm at 60 Hz, temperature class 155 (F), used acc. to temperature class 130 (B), IP23 degree of protection											
250	285	315	988	2420	95.4	0.88	430	250	1LL8 315-6AC□□	1300	
315	360	315	988	3040	95.7	0.89	530	310	1LL8 317-6AC□□	1500	
400	460	355	991	3850	96.1	0.88	680	395	1LL8 355-6AC□□	2000	
500	575	355	991	4820	96.4	0.88	850	495	1LL8 357-6AC□□	2200	
560	645	400	993	5390	96.6	0.87	960	560	1LL8 403-6AC□□	2800	
630	725	400	993	6060	96.7	0.88	1060	620	1LL8 405-6AC□□	3000	
710	815	400	993	6830	96.7	0.88	1200	700	1LL8 407-6AC□□	3200	
800	920	450	993	7700	96.8	0.87	–	790	1LL8 453-6AD□□	4000	
900	1035	450	992	8660	96.8	0.88	–	880	1LL8 455-6AD□□	4200	
1000	1150	450	993	9620	96.9	0.88	–	980	1LL8 457-6AD□□	4500	
8-pole, 750 rpm at 50 Hz, 900 rpm at 60 Hz, temperature class 155 (F), used acc. to temperature class 130 (B), IP23 degree of protection											
200	230	315	738	2590	94.7	0.82	370	215	1LL8 315-8AC□□	1300	
250	285	315	738	3240	95.0	0.82	465	270	1LL8 317-8AC□□	1500	
315	360	355	740	4070	95.5	0.83	570	335	1LL8 355-8AC□□	2000	
400	460	355	740	5160	95.6	0.84	720	415	1LL8 357-8AC□□	2200	
450	515	400	741	5800	95.9	0.84	810	465	1LL8 403-8AD□□	2800	
500	575	400	741	6440	96.1	0.84	890	520	1LL8 405-8AD□□	3000	
560	645	400	742	7210	96.2	0.83	1020	590	1LL8 407-8AD□□	3200	
630	745	450	743	8100	96.3	0.82	1160	670	1LL8 453-8AD□□	4000	
710	815	450	743	9130	96.4	0.83	1280	740	1LL8 455-8AD□□	4200	
800	920	450	743	10300	96.5	0.83	–	840	1LL8 457-8AD□□	4500	

A service factor (SF) of 1.05 is stamped onto all 1LL8 motors for mains-fed operation.

Order No. supplements

Motor type	Penultimate position: Voltage code				Final position: Type of construction code			
	400 VΔ/690 VY	500 VΔ	690 VΔ	60 Hz 460 VΔ (see "Introduction" for outputs at 60 Hz)	Without flange IM B3	With flange IM V1 without protective cover	IM V1 with protective cover ¹⁾	IM B35
	6	5	0	9 L2F	0	8	4	6
6-pole								
1LL8 315-...□□ to 1LL8 407-...□□	□	○	– ²⁾	○	□	✓	✓	✓
1LL8 453-...□□ to 1LL8 457-...□□	–	○	□	O. R.	□	✓	✓	✓
8-pole								
1LL8 315-...□□ to 1LL8 455-...□□	□	○	– ²⁾	○	□	✓	✓	✓
1LL8 457-...□□	–	○	□	O. R.	□	✓	✓	✓

- Standard version
- Without additional charge
- ✓ With additional charge
- O. R. Possible on request
- Not possible

Order other voltages with voltage code **9** in the penultimate position and the corresponding order code (see "Special versions" in the "Selection and ordering data" under "Voltages").

Voltages or frequencies that are not covered by the predefined options can be ordered with order code **L1Y**. In this case, the output, voltage and frequency must be specified.

¹⁾ The "Second shaft extension" option, order code **K16** is not possible.

²⁾ As special version with voltage code **9** and order code **L1Y** (specify output, voltage and frequency).

IEC Squirrel-Cage Motors

Non-standard motors frame size 315 and above

Self-ventilated motors with through ventilation
for mains-fed operation – Cast-iron series 1LL8

Selection and ordering data (continued)

Order No.	Locked-rotor torque	Locked-rotor current	Break-down torque	Torque class	Moment of inertia	Noise at rated output		Mech. limit speed	Parallel feeders required		
	At 50 Hz and for direct online starting as multiple of rated torque			CL	J kgm ²	Measuring surface sound pressure level at 50 Hz	Sound power level at 50 Hz	n_{max} rpm	400 V	500 V	690 V
	T_{LR}/T_{rated}	I_{LR}/I_{rated}	T_B/T_{rated}			L_{pA} dB(A)	L_{WA} dB(A)				
6-pole, 1000 rpm at 50 Hz, 1200 rpm at 60 Hz, temperature class 155 (F), used acc. to temperature class 130 (B), IP23 degree of protection											
1LL8 315-6AC□□	1.6	7	2.6	10	6	70	84	2950/2600 ¹⁾			
1LL8 317-6AC□□	1.7	7	2.6	10	7.3	70	84	2950/2600 ¹⁾	Yes		
1LL8 355-6AC□□	1.7	7	2.5	10	13	73	88	2500/2200 ¹⁾	Yes		
1LL8 357-6AC□□	1.8	7	2.6	10	16	73	88	2500/2200 ¹⁾	Yes	Yes	
1LL8 403-6AC□□	1.8	7	2.6	10	21	76	91	2200/1900 ¹⁾			
1LL8 405-6AC□□	1.8	7	2.6	10	24	76	91	2200/1900 ¹⁾	Yes		
1LL8 407-6AC□□	1.8	7	2.5	10	27	76	91	2200/1900 ¹⁾	Yes		
1LL8 453-6AD□□	1.5	7	2.5	7	35	78	93	2100/1800 ¹⁾	Yes	Yes	
1LL8 455-6AD□□	1.5	7	2.4	7	39	78	93	2100/1800 ¹⁾		Yes	
1LL8 457-6AD□□	1.5	7	2.5	7	44	78	93	2100/1800 ¹⁾		Yes	
8-pole, 750 rpm at 50 Hz, 900 rpm at 60 Hz, temperature class 155 (F), used acc. to temperature class 130 (B), IP23 degree of protection											
1LL8 315-8AC□□	1.6	5.8	2.4	10	6	67	81	2950/2600 ¹⁾			
1LL8 317-8AC□□	1.6	5.8	2.4	10	7.3	67	81	2950/2600 ¹⁾			
1LL8 355-8AC□□	1.6	6	2.4	10	13	69	84	2500/2200 ¹⁾			
1LL8 357-8AC□□	1.6	6	2.3	10	16	69	84	2500/2200 ¹⁾	Yes		
1LL8 403-8AD□□	1.3	5.8	2.3	7	21	72	87	2200/1900 ¹⁾			
1LL8 405-8AD□□	1.4	5.8	2.4	7	24	72	87	2200/1900 ¹⁾			
1LL8 407-8AD□□	1.4	6	2.4	7	27	72	87	2200/1900 ¹⁾	Yes		
1LL8 453-8AD□□	1.3	5.8	2.3	7	35	74	89	2100/1800 ¹⁾	Yes		
1LL8 455-8AD□□	1.3	5.8	2.3	7	39	74	89	2100/1800 ¹⁾	Yes	Yes	
1LL8 457-8AD□□	1.3	5.8	2.3	7	44	74	89	2100/1800 ¹⁾	Yes	Yes	

¹⁾ For vertical type of construction IM V1.

IEC Squirrel-Cage Motors

Non-standard motors frame size 315 and above

Self-ventilated motors with through-ventilation
for converter-fed operation – Cast-iron series 1LL8

Selection and ordering data

Rated output at		Frame size	Operating values at rated output and sinusoidal supply						Order No.	Price	Weight of IM B3 type of construction approx.
50 Hz	60 Hz		Rated speed at 50 Hz	Rated torque at 50 Hz	Efficiency at 50 Hz 4/4-load	Power factor at 50 Hz 4/4-load	Rated current at 50 Hz 400 V	Rated current at 50 Hz 690 V			
P_{rated} kW	P_{rated} kW	FS	n_{rated} rpm	T_{rated} Nm	η_{rated} %	$\cos\phi_{rated}$	I_{rated} A	I_{rated} A		kg	
2-pole, 3000 rpm at 50 Hz, 3600 rpm at 60 Hz, temperature class 155 (F), used acc. to temperature class 155 (F), IP23 degree of protection, specially for operation on SINAMICS or SIMOVERT MASTERDRIVES with standard insulation for voltages ≤500 V											
315	345	315	2974	1010	96.1	0.92	510	300	1LL8 315-2PCQQ	1300	
400	440	315	2974	1280	96.4	0.92	650	375	1LL8 317-2PCQQ	1500	
450	–	355	2978	1440	96.4	0.91	740	430	1LL8 353-2PDQQ	1900	
500	–	355	2979	1600	96.6	0.92	810	470	1LL8 355-2PDQQ	2000	
630	–	355	2980	2020	96.9	0.93	1000	580	1LL8 357-2PDQQ	2200	
710	–	400	2984	2270	97.0	0.91	1160	670	1LL8 403-2PDQQ	2800	
800	–	400	2984	2560	97.1	0.92	1300	750	1LL8 405-2PDQQ	3000	
900	–	400	2985	2880	97.3	0.92	–	840	1LL8 407-2PDQQ	3200	
1000	–	450	2987	3200	97.3	0.93	–	920	1LL8 453-2PEQQ	4000	
1120	–	450	2986	3580	97.3	0.94	–	1020	1LL8 455-2PEQQ	4200	
1250	–	450	2986	4000	97.4	0.94	–	1140	1LL8 457-2PEQQ	4400	
4-pole, 1500 rpm at 50 Hz, 1800 rpm at 60 Hz, temperature class 155 (F), used acc. to temperature class 155 (F), IP23 degree of protection, specially for operation on SINAMICS or SIMOVERT MASTERDRIVES with standard insulation for voltages ≤500 V											
315	360	315	1483	2030	96.0	0.87	540	315	1LL8 315-4PCQQ	1300	
400	460	315	1484	2570	96.2	0.88	680	395	1LL8 317-4PCQQ	1500	
450	515	355	1487	2890	96.5	0.87	770	450	1LL8 353-4PCQQ	1900	
500	575	355	1487	3210	96.6	0.88	850	490	1LL8 355-4PCQQ	2000	
630	725	355	1488	4040	96.9	0.88	1060	620	1LL8 357-4PCQQ	2200	
710	815	400	1489	4550	96.9	0.88	1200	700	1LL8 403-4PCQQ	2800	
800	920	400	1490	5130	97.0	0.88	1360	780	1LL8 405-4PCQQ	3000	
900	1035	400	1491	5760	97.2	0.87	–	890	1LL8 407-4PCQQ	3200	
1000	1150	450	1492	6400	97.2	0.86	–	1000	1LL8 453-4PDQQ	4000	
1120	1280	450	1491	7170	97.2	0.89	–	1080	1LL8 455-4PDQQ	4200	
1250	1430	450	1490	8010	97.2	0.89	–	1200	1LL8 457-4PDQQ	4400	

Order No. supplements

Motor type	Penultimate position: Voltage code				Final position: Type of construction code			
	400 VΔ	400 VΔ/690 VY ¹⁾	500 VΔ	690 VΔ ¹⁾	Without flange IM B3	With flange		
						IM V1 without protective cover	IM V1 with protective cover	IM B35
	4	8	5	7	0	8	4	6
1LL8 315-... QQ to 1LL8 405-... QQ	○	□	○	–	□	✓	✓	✓
1LL8 407-... QQ to 1LL8 457-... QQ	–	–	○	□	□	✓	✓	✓

- Standard version
- Without additional charge
- ✓ With additional charge
- Not possible

Order other voltages with voltage code **9** in the penultimate position and the corresponding order code (see “Special versions” in the “Selection and ordering data” under “Voltages”).

Voltages or frequencies that are not covered by the predefined options can be ordered with order code **L1Y**. In this case, the output, voltage and frequency must be specified.

¹⁾ Motors with standard insulation can only be operated with converter circuit (du/dt or sinusoidal filter).

IEC Squirrel-Cage Motors

Non-standard motors frame size 315 and above

Self-ventilated motors with through-ventilation
for converter-fed operation – Cast-iron series 1LL8

Selection and ordering data (continued)

Order No.	Breakdown torque at 50 Hz as multiple of rated torque	Torque class	Moment of inertia	Measuring surface sound pressure level at 50 Hz	Sound power level at 50 Hz	Mech. limit speed		Parallel feeders required		
						T_B/T_{rated}	CL	J kgm ²	L_{pA} dB(A)	L_{WA} dB(A)
2-pole, 3000 rpm at 50 Hz, 3600 rpm at 60 Hz, temperature class 155 (F), used acc. to temperature class 155 (F), IP23 degree of protection, specially for operation on SINAMICS or SIMOVERT MASTERDRIVES with standard insulation for voltages ≤500 V										
1LL8 315-2PC□□	2.8	10	2.7	84 ¹⁾	99	3600	60			Yes
1LL8 317-2PC□□	2.8	10	3.3	84 ¹⁾	99	3600	60			Yes
1LL8 353-2PD□□	2.6	7	4.8	86 ¹⁾	101	3600/3100 ²⁾	60/52 ²⁾		Yes	Yes
1LL8 355-2PD□□	2.6	7	5.3	86 ¹⁾	101	3600/3100 ²⁾	60/52 ²⁾		Yes	Yes
1LL8 357-2PD□□	2.6	7	6.4	86 ¹⁾	101	3600/3100 ²⁾	60/52 ²⁾		Yes	
1LL8 403-2PD□□	2.6	7	8.6	88 ¹⁾	103	3600/3100 ²⁾	60/52 ²⁾		Yes	
1LL8 405-2PD□□	2.6	7	9.6	88 ¹⁾	103	3600/3100 ²⁾	60/52 ²⁾		Yes	Yes
1LL8 407-2PD□□	2.7	7	11	88 ¹⁾	103	3600/3100 ²⁾	60/52 ²⁾			Yes
1LL8 453-2PE□□	2.9	5	19	90 ¹⁾	105	3000	50			Yes
1LL8 455-2PE□□	2.7	5	21	90 ¹⁾	105	3000	50		Yes	Yes
1LL8 457-2PE□□	2.6	5	23	90 ¹⁾	105	3000	50		Yes	Yes
4-pole, 1500 rpm at 50 Hz, 1800 rpm at 60 Hz, temperature class 155 (F), used acc. to temperature class 155 (F), IP23 degree of protection, specially for operation on SINAMICS or SIMOVERT MASTERDRIVES with standard insulation for voltages ≤500 V										
1LL8 315-4PC□□	2.7	10	3.6	75	90	3000/2600 ²⁾	100/87 ²⁾			Yes
1LL8 317-4PC□□	2.7	10	4.4	75	90	3000/2600 ²⁾	100/87 ²⁾			Yes
1LL8 353-4PC□□	2.6	10	6.1	77	92	2500/2200 ²⁾	83/73 ²⁾		Yes	Yes
1LL8 355-4PC□□	2.6	10	6.8	77	92	2500/2200 ²⁾	83/73 ²⁾		Yes	Yes
1LL8 357-4PC□□	2.7	10	8.5	77	92	2500/2200 ²⁾	83/73 ²⁾		Yes	
1LL8 403-4PC□□	2.4	10	13	81	96	2200/1900 ²⁾	73/63 ²⁾		Yes	
1LL8 405-4PC□□	2.5	10	14	81	96	2200/1900 ²⁾	73/63 ²⁾		Yes	Yes
1LL8 407-4PC□□	2.6	10	16	81	96	2200/1900 ²⁾	73/63 ²⁾			Yes
1LL8 453-4PD□□	2.8	7	23	84	99	2100/1800 ²⁾	70/60 ²⁾			Yes
1LL8 455-4PD□□	2.6	7	26	84	99	2100/1800 ²⁾	70/60 ²⁾		Yes	Yes
1LL8 457-4PD□□	2.5	7	28	84	99	2100/1800 ²⁾	70/60 ²⁾		Yes	Yes

¹⁾ The noise values for 1LL8, 2-pole are for guidance only.

²⁾ For vertical type of construction IM V1.

IEC Squirrel-Cage Motors

Non-standard motors frame size 315 and above

Self-ventilated motors with through-ventilation
for converter-fed operation – Cast-iron series 1LL8

Selection and ordering data (continued)

Rated output at		Frame size	Operating values at rated output and sinusoidal supply						Order No.	Price	Weight of IM B3 type of construction approx.
50 Hz	60 Hz		Rated speed at 50 Hz	Rated torque at 50 Hz	Efficiency at 50 Hz 4/4-load	Power factor at 50 Hz 4/4-load	Rated current at 50 Hz 400 V	Rated current at 50 Hz 690 V			
P_{rated} kW	P_{rated} kW	FS	n_{rated} rpm	T_{rated} Nm	η_{rated} %	$\cos\phi_{rated}$	I_{rated} A	I_{rated} A	For Order No. supplements for voltage and type of construction, see table below	kg	
6-pole, 1000 rpm at 50 Hz, 1200 rpm at 60 Hz, temperature class 155 (F), used acc. to temperature class 155 (F), IP23 degree of protection, specially for operation on SINAMICS or SIMOVERT MASTERDRIVES with standard insulation for voltages ≤500 V											
250	285	315	988	2420	95.4	0.88	430	250	1LL8 315-6PC□□	1300	
315	360	315	988	3040	95.7	0.89	530	310	1LL8 317-6PC□□	1500	
400	460	355	991	3850	96.1	0.88	680	395	1LL8 355-6PC□□	2000	
500	575	355	991	4820	96.4	0.88	850	495	1LL8 357-6PC□□	2200	
560	645	400	993	5390	96.6	0.87	960	560	1LL8 403-6PC□□	2800	
630	725	400	993	6060	96.7	0.88	1060	620	1LL8 405-6PC□□	3000	
710	815	400	993	6830	96.7	0.88	1200	700	1LL8 407-6PC□□	3200	
800	920	450	993	7700	96.8	0.87	1380	790	1LL8 453-6PD□□	4000	
900	1035	450	992	8660	96.8	0.88	–	880	1LL8 455-6PD□□	4200	
1000	1150	450	993	9620	96.9	0.88	–	980	1LL8 457-6PD□□	4500	
8-pole, 750 rpm at 50 Hz, 900 rpm at 60 Hz, temperature class 155 (F), used acc. to temperature class 155 (F), IP23 degree of protection, specially for operation on SINAMICS or SIMOVERT MASTERDRIVES with standard insulation for voltages ≤500 V											
200	230	315	738	2590	94.7	0.82	370	215	1LL8 315-8PC□□	1300	
250	285	315	738	3240	95.0	0.82	465	270	1LL8 317-8PC□□	1500	
315	360	355	740	4070	95.5	0.83	570	335	1LL8 355-8PC□□	2000	
400	460	355	740	5160	95.6	0.84	720	415	1LL8 357-8PC□□	2200	
450	515	400	741	5800	95.9	0.84	810	465	1LL8 403-8PD□□	2800	
500	575	400	741	6440	96.1	0.84	890	520	1LL8 405-8PD□□	3000	
560	645	400	742	7210	96.2	0.83	1020	590	1LL8 407-8PD□□	3200	
630	745	450	743	8100	96.3	0.82	1160	670	1LL8 453-8PD□□	4000	
710	815	450	743	9130	96.4	0.83	1280	740	1LL8 455-8PD□□	4200	
800	920	450	743	10300	96.5	0.83	–	840	1LL8 457-8PD□□	4500	

Order No. supplements

Motor type	Penultimate position: Voltage code				Final position: Type of construction code			
	400 VΔ	400 VΔ/690 VY ¹⁾	500 VΔ	690 VΔ ¹⁾	Without flange IM B3	With flange		IM B35
	4	8	5	7	0	IM V1 without protective cover	IM V1 with protective cover ²⁾	6
6-pole								
1LL8 315-...□□ to 1LL8 453-...□□	○	□	○	–	□	✓	✓	✓
1LL8 455-...□□ to 1LL8 457-...□□	–	–	○	□	□	✓	✓	✓
8-pole								
1LL8 315-...□□ to 1LL8 455-...□□	○	□	○	– ³⁾	□	✓	✓	✓
1LL8 457-...□□	–	–	○	□	□	✓	✓	✓

- Standard version
- Without additional charge
- ✓ With additional charge
- Not possible

Order other voltages with voltage code **9** in the penultimate position and the corresponding order code (see "Special versions" in the "Selection and ordering data" under "Voltages").

Voltages or frequencies that are not covered by the predefined options can be ordered with order code **L1Y**. In this case, the output, voltage and frequency must be specified.

¹⁾ Motors with standard insulation can only be operated with converter circuit (du/dt or sinusoidal filter).

²⁾ The "Second shaft extension" option, order code **K16** is not possible.

³⁾ As special version with voltage code **"9"** and order code **L1Y** (specify output, voltage and frequency).

IEC Squirrel-Cage Motors

Non-standard motors frame size 315 and above

Self-ventilated motors with through-ventilation
for converter-fed operation – Cast-iron series 1LL8

Selection and ordering data (continued)

Order No.	Breakdown torque at 50 Hz as multiple of rated torque	Torque class	Moment of inertia	Measuring surface sound pressure level at 50 Hz	Sound power level at 50 Hz	Mech. limit speed		Parallel feeders required		
						T_B/T_{rated}	CL	J kgm ²	L_{pA} dB(A)	L_{WA} dB(A)
6-pole, 1000 rpm at 50 Hz, 1200 rpm at 60 Hz, temperature class 155 (F), used acc. to temperature class 155 (F), IP23 degree of protection, specially for operation on SINAMICS or SIMOVERT MASTERDRIVES with standard insulation for voltages ≤500 V										
1LL8 315-6PC□□	2.6	10	6.0	70	84	2950/2600 ¹⁾	147/130 ¹⁾			
1LL8 317-6PC□□	2.6	10	7.3	70	84	2950/2600 ¹⁾	147/130 ¹⁾	Yes		
1LL8 355-6PC□□	2.5	10	13	73	88	2500/2200 ¹⁾	125/110 ¹⁾	Yes		
1LL8 357-6PC□□	2.6	10	16	73	88	2500/2200 ¹⁾	125/110 ¹⁾	Yes	Yes	
1LL8 403-6PC□□	2.6	10	21	76	91	2200/1900 ¹⁾	110/95 ¹⁾			
1LL8 405-6PC□□	2.6	10	24	76	91	2200/1900 ¹⁾	110/95 ¹⁾	Yes		
1LL8 407-6PC□□	2.5	10	27	76	91	2200/1900 ¹⁾	110/95 ¹⁾	Yes		
1LL8 453-6PD□□	2.5	7	35	78	93	2100/1800 ¹⁾	105/90 ¹⁾	Yes	Yes	
1LL8 455-6PD□□	2.4	7	39	78	93	2100/1800 ¹⁾	105/90 ¹⁾	Yes		
1LL8 457-6PD□□	2.5	7	44	78	93	2100/1800 ¹⁾	105/90 ¹⁾	Yes		
8-pole, 750 rpm at 50 Hz, 900 rpm at 60 Hz, temperature class 155 (F), used acc. to temperature class 155 (F), IP23 degree of protection, specially for operation on SINAMICS or SIMOVERT MASTERDRIVES with standard insulation for voltages ≤500 V										
1LL8 315-8PC□□	2.4	10	6.0	67	81	2950/2600 ¹⁾	196/173 ¹⁾			
1LL8 317-8PC□□	2.4	10	7.3	67	81	2950/2600 ¹⁾	196/173 ¹⁾			
1LL8 355-8PC□□	2.4	10	13	69	84	2500/2200 ¹⁾	166/146 ¹⁾			
1LL8 357-8PC□□	2.3	10	16	69	84	2500/2200 ¹⁾	166/146 ¹⁾	Yes		
1LL8 403-8PD□□	2.3	7	21	72	87	2200/1900 ¹⁾	146/126 ¹⁾			
1LL8 405-8PD□□	2.4	7	24	72	87	2200/1900 ¹⁾	146/126 ¹⁾			
1LL8 407-8PD□□	2.4	7	27	72	87	2200/1900 ¹⁾	146/126 ¹⁾	Yes		
1LL8 453-8PD□□	2.3	7	35	74	89	2100/1800 ¹⁾	140/120 ¹⁾	Yes		
1LL8 455-8PD□□	2.3	7	39	74	89	2100/1800 ¹⁾	140/120 ¹⁾	Yes	Yes	
1LL8 457-8PD□□	2.3	7	44	74	89	2100/1800 ¹⁾	140/120 ¹⁾	Yes	Yes	

¹⁾ For vertical type of construction IM V1.

IEC Squirrel-Cage Motors

Non-standard motors frame size 315 and above

Self-ventilated motors with through-ventilation
for converter-fed operation – Cast-iron series 1LL8

Selection and ordering data (continued)

Rated output at		Frame size	Operating values at rated output and sinusoidal supply						Order No.	Price	Weight of IM B3 type of construction approx.
50 Hz	60 Hz		Rated speed at 50 Hz	Rated torque at 50 Hz	Efficiency at 50 Hz 4/4-load	Efficiency at 50 Hz 3/4-load	Power factor at 50 Hz 4/4-load	Rated current at 50 Hz 690 V			
P_{rated} kW	P_{rated} kW	FS	n_{rated} rpm	T_{rated} Nm	η_{rated} %	η_{rated} %	$\cos\phi_{\text{rated}}$	I_{rated} A		m kg	
2-pole, 3000 rpm at 50 Hz, 3600 rpm at 60 Hz, temperature class 155 (F), used acc. to temperature class 155 (F), IP23 degree of protection, specially for operation on SINAMICS or SIMOVERT MASTERDRIVES with special insulation for voltages >500 V to 690 V											
300	330	315	2977	962	95.9		0.91	290	1LL8315-2PM8□	1300	
380	415	315	2977	1219	96.3		0.91	365	1LL8317-2PM8□	1500	
435	475	355	2982	1393	96.2		0.90	420	1LL8353-2PM8□	1900	
485	530	355	2982	1553	96.5		0.90	465	1LL8355-2PM8□	2000	
610	670	355	2983	1953	96.8		0.91	580	1LL8357-2PM8□	2200	
690	755	400	2986	2207	96.9		0.91	650	1LL8403-2PM8□	2800	
770	845	400	2986	2463	96.9		0.91	730	1LL8405-2PM8□	3000	
860	945	400	2988	2749	97.2		0.92	800	1LL8407-2PM7□	3200	
965	1060	450	2988	3084	97.2		0.92	2x450	1LL8453-2PM7□	4000	
1085	1190	450	2987	3469	97.2		0.93	2x500	1LL8455-2PM7□	4200	
1210	1330	450	2985	3871	97.3		0.93	2x560	1LL8457-2PM7□	4400	
4-pole, 1500 rpm at 50 Hz, 1800 rpm at 60 Hz, temperature class 155 (F), used acc. to temperature class 155 (F), IP23 degree of protection, specially for operation on SINAMICS or SIMOVERT MASTERDRIVES with special insulation for voltages >500 V to 690 V											
295	340	315	1485	1897	95.7		0.86	300	1LL8315-4PM8□	1300	
365	420	315	1487	2344	96.1		0.87	365	1LL8317-4PM8□	1500	
430	495	355	1489	2758	96.3		0.86	435	1LL8353-4PM8□	1900	
480	550	355	1489	3079	96.5		0.87	480	1LL8355-4PM8□	2000	
600	690	355	1490	3846	96.8		0.86	600	1LL8357-4PM8□	2200	
690	790	400	1491	4420	96.7		0.87	690	1LL8403-4PM8□	2800	
780	895	400	1491	4996	96.9		0.88	770	1LL8405-4PM8□	3000	
870	1000	400	1493	5565	97.1		0.85	880	1LL8407-4PM7□	3200	
980	1125	450	1493	6269	97.1		0.85	2x495	1LL8453-4PM7□	4000	
1095	1255	450	1492	7009	97.1		0.88	2x530	1LL8455-4PM7□	4200	
1225	1405	450	1491	7846	97.1		0.88	2x600	1LL8457-4PM7□	4400	

Order No. supplements

Motor type	Final position: Type of construction code			
	Without flange		With flange	
	IM B3	IM V1 without protective cover	IM V1 with protective cover	IM B35
	0	8	4	6
1LL8 315-... □□ to 1LL8 457-... □□	□	✓	✓	✓

- Standard version
- ✓ With additional charge

The voltage code is already in the Order No. as the penultimate position.

Assignment:

7 = 690 VΔ

8 = 400 VΔ/690 VY

Order other voltages with voltage code **9** in the penultimate position and the corresponding order code (see "Special versions" in the "Selection and ordering data" under "Voltages").

Voltages or frequencies that are not covered by the predefined options can be ordered with order code **L1Y**. In this case, the output, voltage and frequency must be specified.

IEC Squirrel-Cage Motors

Non-standard motors frame size 315 and above

Self-ventilated motors with through-ventilation
for converter-fed operation – Cast-iron series 1LL8

Selection and ordering data (continued)

Order No.	Breakdown torque at 50 Hz as multiple of rated torque	Parallel feeders required
	T_B/T_{rated}	690 V
2-pole, 3000 rpm at 50 Hz, 3600 rpm at 60 Hz, temperature class 155 (F), used acc. to temperature class 155 (F), IP23 degree of protection, specially for operation on SINAMICS or SIMOVERT MASTERDRIVES with special insulation for voltages >500 V to 690 V		
1LL8315-2PM8□	2.9	
1LL8317-2PM8□	2.9	
1LL8353-2PM8□	2.7	
1LL8355-2PM8□	2.7	
1LL8357-2PM8□	2.7	
1LL8403-2PM8□	2.7	
1LL8405-2PM8□	2.7	
1LL8407-2PM7□	2.8	
1LL8453-2PM7□	3.0	Yes
1LL8455-2PM7□	2.8	Yes
1LL8457-2PM7□	2.7	Yes
4-pole, 1500 rpm at 50 Hz, 1800 rpm at 60 Hz, temperature class 155 (F), used acc. to temperature class 155 (F), IP23 degree of protection, specially for operation on SINAMICS or SIMOVERT MASTERDRIVES with special insulation for voltages >500 V to 690 V		
1LL8315-4PM8□	2.9	
1LL8317-4PM8□	3.0	
1LL8353-4PM8□	2.7	
1LL8355-4PM8□	2.7	
1LL8357-4PM8□	2.8	
1LL8403-4PM8□	2.5	
1LL8405-4PM8□	2.6	
1LL8407-4PM7□	2.7	
1LL8453-4PM7□	2.9	Yes
1LL8455-4PM7□	2.7	Yes
1LL8457-4PM7□	2.6	Yes

IEC Squirrel-Cage Motors

Non-standard motors frame size 315 and above

Self-ventilated motors with through-ventilation
for converter-fed operation – Cast-iron series 1LL8

Selection and ordering data (continued)

Rated output at		Frame size	Operating values at rated output and sinusoidal supply						Order No. For Order No. supplements for voltage and type of construction, see table below	Price	Weight of IM B3 type of construction approx. m kg
50 Hz	60 Hz		Rated speed at 50 Hz	Rated torque at 50 Hz	Efficiency at 50 Hz 4/4-load	Efficiency at 50 Hz 3/4-load	Power factor at 50 Hz 4/4-load	Rated current at 50 Hz 690 V			
P_{rated} kW	P_{rated} kW	FS	n_{rated} rpm	T_{rated} Nm	η_{rated} %	η_{rated} %	$\cos\phi_{\text{rated}}$	I_{rated} A			
6-pole, 1000 rpm at 50 Hz, 1200 rpm at 60 Hz, temperature class 155 (F), used acc. to temperature class 155 (F), IP23 degree of protection, specially for operation on SINAMICS or SIMOVERT MASTERDRIVES with special insulation for voltages >500 V to 690 V											
235	270	315	990	2267	95.0		0.87	240	1LL8315-6PM8□	1300	
295	335	315	990	2846	95.3		0.87	295	1LL8317-6PM8□	1500	
380	435	355	992	3658	95.6		0.87	380	1LL8355-6PM8□	2000	
475	545	355	993	4568	96.3		0.87	475	1LL8357-6PM8□	2200	
540	620	400	993	5193	96.4		0.86	550	1LL8403-6PM8□	2800	
610	700	400	994	5861	96.5		0.87	610	1LL8405-6PM8□	3000	
690	790	400	993	6636	96.6		0.87	690	1LL8407-6PM8□	3200	
780	895	450	993	7502	96.7		0.87	780	1LL8453-6PM8□	4000	
870	1000	450	993	8367	96.8		0.88	850	1LL8455-6PM7□	4200	
975	1120	450	993	9377	96.8		0.88	2x480	1LL8457-6PM7□	4500	
8-pole, 750 rpm at 50 Hz, 900 rpm at 60 Hz, temperature class 155 (F), used acc. to temperature class 155 (F), IP23 degree of protection, specially for operation on SINAMICS or SIMOVERT MASTERDRIVES with special insulation for voltages >500 V to 690 V											
180	205	315	738	2329	94.1		0.81	198	1LL8315-8PM8□	1300	
225	255	315	740	2904	94.8		0.80	250	1LL8317-8PM8□	1500	
285	325	355	741	3673	95.1		0.81	310	1LL8355-8PM8□	2000	
365	415	355	741	4704	95.4		0.83	385	1LL8357-8PM8□	2200	
420	480	400	741	5413	95.5		0.83	445	1LL8403-8PM8□	2800	
465	530	400	742	5985	96.0		0.83	490	1LL8405-8PM8□	3000	
525	600	400	742	6757	96.0		0.82	560	1LL8407-8PM8□	3200	
610	700	450	742	7851	95.9		0.82	650	1LL8453-8PM8□	4000	
690	790	450	742	8881	96.0		0.82	730	1LL8455-8PM8□	4200	
760	870	450	742	9782	96.0		0.83	800	1LL8457-8PM8□	4500	

Order No. supplements

Motor type	Final position: Type of construction code			
	Without flange IM B3	With flange IM V1 without protective cover	IM V1 with protective cover	IM B35
1LL8 315-... □□ to 1LL8 457-... □□	0 □	8 ✓	4 ✓	6 ✓

- Standard version
- ✓ With additional charge

The voltage code is already in the Order No. as the penultimate position.

Assignment:

7 = 690 VΔ

8 = 400 VΔ/690 VY

Order other voltages with voltage code **9** in the penultimate position and the corresponding order code (see "Special versions" in the "Selection and ordering data" under "Voltages").

Voltages or frequencies that are not covered by the predefined options can be ordered with order code **L1Y**. In this case, the output, voltage and frequency must be specified.

IEC Squirrel-Cage Motors

Non-standard motors frame size 315 and above

Self-ventilated motors with through-ventilation
for converter-fed operation – Cast-iron series 1LL8

Selection and ordering data (continued)

Order No.	Breakdown torque at 50 Hz as multiple of rated torque	Parallel feeders required
	T_B/T_{rated}	690 V
6-pole, 1000 rpm at 50 Hz, 1200 rpm at 60 Hz, temperature class 155 (F), used acc. to temperature class 155 (F), IP23 degree of protection, specially for operation on SINAMICS or SIMOVERT MASTERDRIVES with special insulation for voltages >500 V to 690 V		
1LL8315-6PM8□	2.8	
1LL8317-6PM8□	2.8	
1LL8355-6PM8□	2.6	
1LL8357-6PM8□	2.7	
1LL8403-6PM8□	2.7	
1LL8405-6PM8□	2.7	
1LL8407-6PM8□	2.6	
1LL8453-6PM8□	2.6	
1LL8455-6PM7□	2.5	
1LL8457-6PM7□	2.6	Yes
8-pole, 750 rpm at 50 Hz, 900 rpm at 60 Hz, temperature class 155 (F), used acc. to temperature class 155 (F), IP23 degree of protection, specially for operation on SINAMICS or SIMOVERT MASTERDRIVES with special insulation for voltages >500 V to 690 V		
1LL8315-8PM8□	2.7	
1LL8317-8PM8□	2.7	
1LL8355-8PM8□	2.7	
1LL8357-8PM8□	2.5	
1LL8403-8PM8□	2.5	
1LL8405-8PM8□	2.6	
1LL8407-8PM8□	2.6	
1LL8453-8PM8□	2.4	
1LL8455-8PM8□	2.4	
1LL8457-8PM8□	2.4	

IEC Squirrel-Cage Motors

Non-standard motors frame size 315 and above

Special versions

Overview

Motor protection

KTY 84 temperature sensor:

Order code **A23**:

1 x KTY 84-130 (+ 1 x KTY 84-130 as spare)

The sensor is a semi-conductor sensor that changes its resistance depending on temperature in accordance with a defined, approximately linear characteristic. The temperature sensor is embedded in the winding head of the motor in the same manner as a PTC thermistor.

PT100 resistance thermometers

Order code **A61**: 6 PT100 resistance thermometers

The thermometer changes its resistance depending on the temperature in accordance with a defined, almost linear characteristic. The temperature sensor is embedded in the winding head of the motor in the same manner as a PTC thermistor.

Evaluation of the KTY or PT100 sensor is performed, for example, in the converter.

For motors for mains-fed operation, the 3RS10 temperature monitoring device that forms part of the protective equipment must be ordered separately, for further details, see Catalog LV 1.

For all non-standard motors of series 1LA8, 1PQ8 and 1LL8, if order code **A23** or **A61** is used, the standard PTC thermistors will be omitted. A combination of **A12** and **A61** or **A12** and **A23** is possible on request for an additional charge.

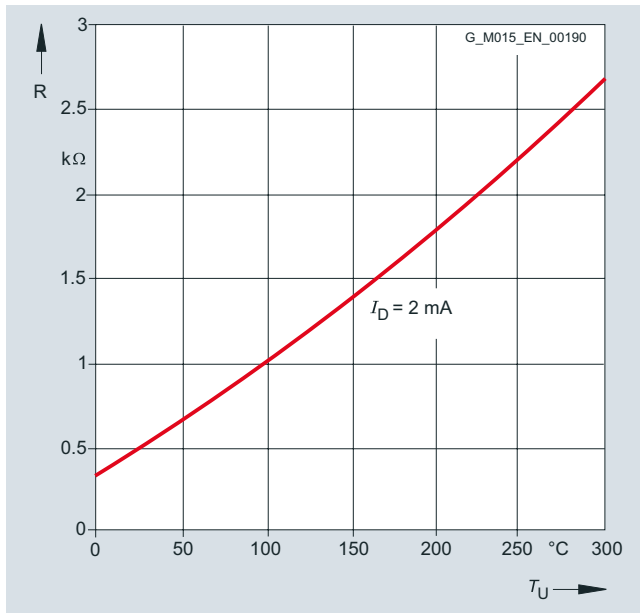

IEC Squirrel-Cage Motors

Non-standard motors frame size 315 and above

Special versions

Selection and ordering data

Voltages

Additional order codes for other voltages or voltage codes
(without **-Z** supplement)

For some non-standard voltages at 50 or 60 Hz, order codes are specified. They are ordered by specifying the code digit **9** for voltage in the 11th position of the Order No. and the appropriate order code.

Special versions	Voltage code 11th position of Order No.	Additional identification code with order code and plain text if required	Motor type frame size			
			315	355	400	450
Self-ventilated motors for mains-fed operation – Cast-iron series 1LA8						
Self-ventilated motors for converter-fed operation – Cast-iron series 1LA8						
			1LA8			
Voltage at 60 Hz						
380 VΔ/660 VY; 50 Hz output ¹⁾	9	L2C	✓	✓	✓	✓
380 VΔ/660 VY; 60 Hz output ¹⁾	9	L2D	✓	✓	✓	✓
440 VΔ; 50 Hz output ¹⁾	9	L2R	✓	✓	✓	✓
440 VΔ; 60 Hz output ¹⁾	9	L2X	✓	✓	✓	✓
460 VΔ; 50 Hz output ¹⁾	9	L2T	✓	✓	✓	✓
460 VΔ; 60 Hz output ¹⁾	9	L2F	✓	✓	✓	✓
575 VΔ; 50 Hz output	9	L2V	✓	✓	✓	✓
575 VΔ; 60 Hz output	9	L2M	✓	✓	✓	✓
Non-standard voltage and/or frequencies						
Standard winding (winding according to voltage code 0, 4, 5, 6, 7 or 8; rating plate will be stamped in accordance with order) ²⁾	9	L8Y •	✓	✓	✓	✓
Non-standard winding for voltages between 380 and 690 V (voltages outside this range are available on request) ²⁾	9	L1Y •	✓	✓	✓	✓

- ✓ With additional charge
- This order code only determines the price of the version – Additional plain text is required.

¹⁾ Only possible with rated outputs of up to 630 kW.

²⁾ Plain text must be specified in the order: Voltage, frequency, circuit, required rated output in kW.

IEC Squirrel-Cage Motors

Non-standard motors frame size 315 and above

Special versions

Special versions	Voltage code 11th position of Order No.	Additional identification code with order code and plain text if required	Motor type frame size			
			315	355	400	450
Forced-air cooled motors with mounted separately driven fan for converter-fed operation – Cast-iron series 1PQ8						
1PQ8						
Voltage at 60 Hz						
380 VΔ/660 VY; 50 Hz output ¹⁾	9	L2C	✓	✓	✓	✓
380 VΔ/660 VY; 60 Hz output ¹⁾	9	L2D	✓	✓	✓	✓
440 VΔ; 50 Hz output ¹⁾	9	L2R	✓	✓	✓	✓
440 VΔ; 60 Hz output ¹⁾	9	L2X	✓	✓	✓	✓
460 VΔ; 50 Hz output ¹⁾	9	L2T	✓	✓	✓	✓
460 VΔ; 60 Hz output ¹⁾	9	L2F	✓	✓	✓	✓
575 VΔ; 50 Hz output	9	L2V	✓	✓	✓	✓
575 VΔ; 60 Hz output	9	L2M	✓	✓	✓	✓
Non-standard voltage and/or frequencies						
Standard winding (winding according to voltage code 4, 5, 7 or 8; rating plate will be stamped in accordance with order) ²⁾	9	L8Y •	✓	✓	✓	✓
Non-standard winding for voltages between 380 and 690 V (voltages outside this range are available on request) ²⁾	9	L1Y •	✓	✓	✓	✓

- ✓ With additional charge
- This order code only determines the price of the version – Additional plain text is required.

Note:

The order codes listed above are only valid for motor series 1PQ8 with forced-air cooled motor.

The required voltage/frequency according to order code Y81 „Separately driven fan with non-standard voltage/frequency“ must be ordered in plain text with indication of the voltage, frequency and circuit.

¹⁾ Only possible with rated outputs of up to 630 kW.

²⁾ Plain text must be specified in the order: Voltage, frequency, circuit, required rated output in kW.

IEC Squirrel-Cage Motors

Non-standard motors frame size 315 and above

Special versions

Special versions	Voltage code 11th position of Order No.	Additional identification code with order code and plain text if required	Motor type frame size			
			315	355	400	450
Self-ventilated motors with through ventilation for mains-fed and converter-fed operation – Cast-iron series 1LL8						
1LL8						
Voltage at 60 Hz						
380 VΔ/660 VY; 50 Hz output ¹⁾	9	L2C	✓	✓ ³⁾	✓ ³⁾	✓ ³⁾
380 VΔ/660 VY; 60 Hz output ¹⁾	9	L2D	✓	✓	✓	✓
440 VΔ; 50 Hz output ¹⁾	9	L2R	✓	✓	✓	✓
440 VΔ; 60 Hz output ¹⁾	9	L2X	✓	✓	✓	✓
460 VΔ; 50 Hz output ¹⁾	9	L2T	✓	✓	✓	✓
460 VΔ; 60 Hz output ¹⁾	9	L2F	✓	✓	✓	✓
575 VΔ; 50 Hz output	9	L2V	✓	✓	✓	✓
575 VΔ; 60 Hz output	9	L2M	✓	✓	✓	✓
Non-standard voltage and/or frequencies						
Standard winding (winding according to voltage code 0, 5 or 6; rating plate will be stamped in accordance with order) ²⁾	9	L8Y •	✓	✓	✓	✓
Non-standard winding for voltages between 380 and 690 V (voltages outside this range are available on request) ²⁾	9	L1Y •	✓	✓	✓	✓

- ✓ With additional charge
- This order code only determines the price of the version – Additional plain text is required.

¹⁾ Only possible with rated outputs of up to 630 kW.

²⁾ Plain text must be specified in the order: Voltage, frequency, circuit, required rated output in kW.

³⁾ Not possible for 2-pole motors in 60 Hz version of frame size 355 and above.

IEC Squirrel-Cage Motors

Non-standard motors frame size 315 and above

Special versions

Options

Options or order codes (supplement **-Z** is required)

Special versions	Additional identification code -Z with order code and plain text if required	Motor type frame size							
		315	355	400	450	315	355	400	450
Self-ventilated motors for mains-fed and converter-fed operation 1LA8									
		1LA8 Mains-fed operation				1LA8 Converter-fed operation			
Standardline									
Standardline version ¹⁾	B20	○	○	–	–	○	○	–	–
Motor protection									
Motor protection with PTC thermistors with 6 embedded temperature sensors for alarm and tripping ²⁾	A12	□	□	□	□	□	□	□	□
Motor temperature detection with embedded temperature sensor KTY 84-130 ³⁾	A23	○	○	○	○	○	○	○	○
Installation of 6 PT 100 resistance thermometers in stator winding ⁵⁾	A61	✓	✓	✓	✓	✓	✓	✓	✓
Installation of 2 PT 100 screw-in resistance thermometers (basic circuit) for rolling-contact bearings	A72	✓	✓	✓	✓	✓	✓	✓	✓
Motor connection and connection box									
Two-part plate on connection box	K06	✓ ⁴⁾	✓	✓	✓	O. R.	O. R.	O. R.	O. R.
Undrilled entry plate	L01	○ ⁴⁾	○	○	○	○ ⁴⁾	○	○	○
Connection box on RHS	K09	□	□	□	□	□	□	□	□
Connection box on LHS	K10	○	○	○	○	○	○	○	○
Connection box above (1XB1 634 connection box) ⁵⁾	K11	✓	✓	✓	✓	✓	✓	✓	✓
Cable gland DIN 89280, maximum configuration	K57	✓	✓	✓	✓	✓	✓	✓	✓
Rotation of the connection box through 90°, entry from DE	K83	○	○	○	○	○	○	○	○
Rotation of the connection box through 90°, entry from NDE	K84	○	○	○	○	○	○	○	○
Rotation of connection box through 180°	K85	○	○	○	○	○	○	○	○
Larger connection box (1XB1 621 connection box)	M58	✓	□ ⁶⁾	–	–	✓	□ ⁶⁾	–	–
Larger connection box (1XB1 631 connection box)	L00	✓	✓ ⁶⁾	□	□	✓	✓ ⁶⁾	□	□
6 cables protruding, 1.5 m long	L48	O. R.	O. R.	O. R.	O. R.	O. R.	O. R.	O. R.	O. R.
6 cables protruding, 3 m long	L49	O. R.	O. R.	O. R.	O. R.	O. R.	O. R.	O. R.	O. R.
Auxiliary connection box 1XB9 016 (cast-iron)	M50	✓	✓	✓	✓	✓	✓	✓	✓
Auxiliary connection box 1XB3 020 ⁷⁾	L97	✓	✓	✓	✓	✓	✓	✓	✓
Auxiliary connection box 1XB9 014 (aluminum)	M88	✓	✓	✓	✓	✓	✓	✓	✓
Connection box on NDE	M64	✓	✓	✓	✓	✓	✓	✓	✓
Windings and insulation									
Temperature class 155 (F), used acc. to 155 (F), with service factor (SF 1.1, SF 1.05 from frame size 400) ⁸⁾	C11	✓	✓	✓	✓	–	–	–	–
Temperature class 155 (F), used acc. to 155 (F), with increased output (10 %, 5 % from frame size 400) ⁸⁾	C12	✓	✓	✓	✓	–	–	–	–
Temperature class 155 (F), used acc. to 155 (F), with increased coolant temperature (55 °C, 50 °C from frame size 400) ⁸⁾	C13	✓	✓	✓	✓	–	–	–	–
Temperature class 180 (H), used acc. to 155 (F), with service factor (SF 1.1) ⁸⁾	C14	✓	✓	✓	✓	✓	✓	✓	✓

For legend and footnotes, see Page 3/53.

IEC Squirrel-Cage Motors

Non-standard motors frame size 315 and above

Special versions

Special versions	Additional identification code -Z with order code and plain text if required	Motor type frame size							
		315	355	400	450	315	355	400	450
Self-ventilated motors for mains-fed and converter-fed operation 1LA8									
		1LA8 Mains-fed operation				1LA8 Converter-fed operation			
Colors and paint finish									
Standard finish in RAL 7030 stone gray		☐	☐	☐	☐	☐	☐	☐	☐
Standard paint finish in other colors	Y53 • and standard finish RAL	✓	✓	✓	✓	✓	✓	✓	✓
Special finish in RAL 7030 stone gray	K26	✓	✓	✓	✓	✓	✓	✓	✓
Special finish in other colors	Y54 • and special finish RAL	✓	✓	✓	✓	✓	✓	✓	✓
Unpainted (only cast iron parts primed)	K23	○	○	○	○	○	○	○	○
Special technology									
Mounting of brake (incl. brake of Stromag)	H47	O. R.	O. R.	O. R.	O. R.	O. R.	O. R.	O. R.	O. R.
Mounting of LL 861 900 220 rotary pulse encoder	H70	–	–	–	–	✓	✓	✓	✓
Mounting of HOG 10 D 1024 I rotary pulse encoder	H73	–	–	–	–	✓	✓	✓	✓
Prepared for mounting LL 861 900 220	H78	–	–	–	–	✓	✓	✓	✓
Prepared for mounting HOG 10 D 1024 I	H80	–	–	–	–	✓	✓	✓	✓
Mounting a special type of rotary pulse encoder	Y70 • and encoder designation	–	–	–	–	O. R.	O. R.	O. R.	O. R.
Mechanical design and degrees of protection									
Low-noise version for 2-pole motors with clockwise direction of rotation	K37	✓	☐	☐	☐	✓	☐	☐	☐
Low-noise version for 2-pole motors with counter-clockwise direction of rotation	K38	✓	○	○	○	✓	○	○	○
IP56 degree of protection (non-heavy-sea)	K52	✓	✓	✓	✓	✓	✓	✓	✓
Non-rusting screws (externally)	M27	✓	✓	✓	✓	✓	✓	✓	✓
Coolant temperature and site altitude									
Coolant temperature –40 to +40 °C	D03	✓	✓	✓	✓	✓	✓	✓	✓
Coolant temperature –30 to +40 °C	D04	✓	✓	✓	✓	✓	✓	✓	✓
Coolant temperature 45 °C, derating 4 % ⁹⁾	D11	○	○	○	○	○	○	○	○
Coolant temperature 50 °C, derating 8 % ⁹⁾	D12	○	○	○	○	○	○	○	○
Coolant temperature 55 °C, derating 13 % ⁹⁾	D13	○	○	○	○	○	○	○	○
Coolant temperature 60 °C, derating 18 % ⁹⁾	D14	○	○	○	○	○	○	○	○
Designs in accordance with standards and specifications									
Electrical according to NEMA MG1-12	D30	✓	✓	✓	✓	✓	✓	✓	✓
Design according to UL with "Recognition Mark"	D31	✓	✓	✓	✓	✓	✓	✓	✓
Canadian regulations (CSA)	D40	✓	✓	✓	✓	✓	✓	✓	✓

IEC Squirrel-Cage Motors

Non-standard motors frame size 315 and above

Special versions

Special versions	Additional identification code -Z with order code and plain text if required	Motor type frame size								
		315	355	400	450	315	355	400	450	
Self-ventilated motors for mains-fed and converter-fed operation 1LA8										
			1LA8 Mains-fed operation				1LA8 Converter-fed operation			
Design for Zones 1, 2 and 22 according to ATEX ¹⁰⁾										
Design for Zone 2 for mains-fed operation Ex nA II T3 to IEC/EN 60079-15 ^{11) 12) 13)}	M72		✓	✓	✓	✓	–	–	–	–
Design for Zone 2 for converter-fed operation, reduced output Ex nA II T3 to IEC/EN 60079-15 ^{11) 12) 13) 14)}	M73		–	–	–	–	O. R.	O. R.	O. R.	O. R.
Design for Zone 22 for non-conducting dust (IP55) for mains-fed operation ¹³⁾	M35		✓	✓	✓	✓	–	–	–	–
Design for Zone 22 for non-conducting dust (IP55) for converter-fed operation ^{12) 13)}	M39		–	–	–	–	✓	✓	✓	✓
VIK version ^{13) 15)}	K30		✓	✓	–	–	O. R.	O. R.	–	–
Stamping of Ex nA II on VIK rating plate	C27		✓	✓	–	–	O. R.	O. R.	–	–
Bearings and lubrication										
Measuring nipple for SPM shock pulse measurement for bearing inspection	G50		✓	✓	✓	✓	✓	✓	✓	✓
Bearing design for increased cantilever forces ¹⁶⁾	K20		✓	✓	–	–	✓	✓	–	–
Balance and vibration quantity										
Vibration quantity level B	K02		✓	✓	✓	✓	✓	✓	✓	✓
Full key balancing	L68		✓	✓	✓	✓	✓	✓	✓	✓
Shaft and rotor										
Second standard shaft extension ¹⁷⁾	K16		✓	✓	✓	✓	✓	✓	✓	✓
Shaft extension with standard dimensions, without featherkey way	K42		✓	✓	✓	✓	✓	✓	✓	✓
Non-standard cylindrical shaft extension	Y55 • and identification code		✓	✓	✓	✓	✓	✓	✓	✓
Heating and ventilation										
Metal external fan	K35		✓	✓	✓	✓	✓	✓	✓	✓
Anti-condensation heaters for 230 V	K45		✓	✓	✓	✓	✓	✓	✓	✓
Anti-condensation heaters for 115 V	K46		✓	✓	✓	✓	✓	✓	✓	✓
Rating plate and extra rating plates										
Second rating plate, loose	K31		✓	✓	✓	✓	✓	✓	✓	✓
Extra rating plate or rating plate with deviating rating plate data	Y80 • and identification code		✓	✓	✓	✓	✓	✓	✓	✓
Extra rating plate with identification code	Y82 • and identification code		✓	✓	✓	✓	✓	✓	✓	✓
Packaging, safety notes, documentation and test certificates¹⁸⁾										
Document – Electrical data sheet	B31		✓	✓	✓	✓	✓	✓	✓	✓
Document – Order dimension drawing	B32		✓	✓	✓	✓	✓	✓	✓	✓
Document – Load characteristics	B37		O. R.	O. R.	O. R.	O. R.	O. R.	O. R.	O. R.	O. R.
Standard test (routine test) with acceptance	F01		✓	✓	✓	✓	✓	✓	✓	✓
Visual acceptance and report handover with acceptance	F03		✓	✓	✓	✓	✓	✓	✓	✓

For legend and footnotes, see Page 3/53.

IEC Squirrel-Cage Motors

Non-standard motors frame size 315 and above

Special versions

Special versions	Additional identification code -Z with order code and plain text if required	Motor type frame size							
		315	355	400	450	315	355	400	450
Self-ventilated motors for mains-fed and converter-fed operation 1LA8									
		1LA8 Mains-fed operation				1LA8 Converter-fed operation			
Packaging, safety notes, documentation and test certificates ¹⁸⁾ (continued)									
Temperature-rise test, without acceptance	F04	✓	✓	✓	✓	✓	✓	✓	✓
Temperature-rise test, with acceptance	F05	✓	✓	✓	✓	✓	✓	✓	✓
Noise measurement in no-load operation, no noise analysis, no acceptance	F28	✓	✓	✓	✓	✓	✓	✓	✓
Noise measurement in no-load operation, no noise analysis, with acceptance	F29	✓	✓	✓	✓	✓	✓	✓	✓
Noise measurement in no-load operation, with noise analysis, without acceptance	F62	✓	✓	✓	✓	✓	✓	✓	✓
Noise measurement in no-load operation, with noise analysis, with acceptance	F63	✓	✓	✓	✓	✓	✓	✓	✓
Recording of current and torque curves with torque metering shaft during starting, without acceptance	F34	✓	✓	✓	✓	–	–	–	–
Recording of current and torque curves with torque metering shaft during starting, with acceptance	F35	✓	✓	✓	✓	–	–	–	–
Measurement of locked-rotor torque and current, without acceptance	F52	✓	✓	✓	✓	–	–	–	–
Measurement of locked-rotor torque and current, with acceptance	F53	✓	✓	✓	✓	–	–	–	–
Type test with heat run for horizontal motors, without acceptance	F82	✓	✓	✓	✓	✓	✓	✓	✓
Type test with heat run for horizontal motors, with acceptance	F83	✓	✓	✓	✓	✓	✓	✓	✓
Type test with heat run for vertical motors, without acceptance	F92	✓	✓	✓	✓	✓	✓	✓	✓
Type test with heat run for vertical motors, with acceptance	F93	✓	✓	✓	✓	✓	✓	✓	✓

- Standard version
- Without additional charge
- This order code only determines the price of the version – Additional plain text is required.
- R. Possible on request
- ✓ With additional charge
- Not possible

¹⁾ For 4-pole version only, type of construction IM B3, 400 V Δ /690 VY or 500 VA voltage (no special insulation). Only the following short codes can be ordered in combination with the *Standardline*: **A23, A61, A72, G50, H70, H73, K09, K10, K45, K46, K83, K84, K85, L00, L97, M58** (only frame size 315), **M88, Y53**.

²⁾ Evaluation with appropriate tripping unit (see Catalog LV 1) is recommended.

³⁾ The standard thermistors are omitted. If PTC thermistors are required as well as KTYs or PT100s, this must be specified in the order in plain text. A combination of **A12** and **A61** or **A12** and **A23** is possible on request for an additional charge.

⁴⁾ Only possible in combination with the larger connection boxes 1XB1 621 or 1XB1 631 (order codes **M58** or **L00**).

⁵⁾ A combination with the order codes **M88** and **M50** is not possible. Connection box 1XP1 634 can be rotated through 4 x 90°. Cable entry is from NDE or the delivery position. Dimension drawings available on request.

⁶⁾ With 1LA8 357-2 and 1LA8 357-4, connection box 1XB1 631 is supplied in the standard version.

⁷⁾ VIK version is not possible.

⁸⁾ Use according to temperature class 180 (H) is not possible. All 400 V version are available on request. Due to the rated current, a larger connection box of type 1XB9 600, which is part of order code **C14**, is generally provided for frame sizes 400 (2- and 4-pole) and 450 (all no. of poles).

⁹⁾ Site altitude up to 1000 m above sea level.

¹⁰⁾ Explosion-protected encoders are available on request.

¹¹⁾ Only admissible for use in accordance with temperature class 130 (B). PTC thermistors for temperature class 130 (B) are included. For compliance with temperature class 130 (B), derating is necessary in the case of converter-fed operation in Zones 2 and 22. Derating data are available on request.

¹²⁾ These motors do not have a rated voltage range stamped on the rating plate.

¹³⁾ For options **K30, M35, M39, M72, M73** an additional metal external fan order code **K35** must be ordered.

¹⁴⁾ In the order, the "Speed range and torque characteristic" must be specified in plain text. A system test is necessary for $M = \text{constant}$.

¹⁵⁾ The VIK version comprises Zone 2 for mains-fed operation – without Ex nA II marking on rating plate. For 2-pole motors of frame size 315, the low-noise version is also required. Order code **K37** or **K38** and additionally the metal external fan order code **K35**. Note the specified output and dimensions. For 1LA8 353 to 1LA8 357 motors, the connection box cannot be rotated by 4 x 90°.

¹⁶⁾ Not possible for 2-pole motors and motors of vertical type of construction.

¹⁷⁾ Please inquire in the case of 2-pole motors and motors in vertical type of construction.

¹⁸⁾ Type testing is also performed for converter-fed operation.

IEC Squirrel-Cage Motors

Non-standard motors frame size 315 and above

Special versions

Options or order codes (supplement **-Z** is required)

Special versions	Additional identification code -Z with order code and plain text if required	Motor type frame size			
		315	355	400	450
Forced-air cooled motors with mounted separately driven fan for converter-fed operation 1PQ8					
1PQ8					
Converter-fed operation					
Standardline					
Standardline version	B20	–	–	–	–
Motor protection					
Motor protection with PTC thermistors with 6 embedded temperature sensors for alarm and tripping ¹⁾	A12	☐	☐	☐	☐
Motor temperature detection with embedded temperature sensor KTY 84-130 ²⁾	A23	○	○	○	○
Installation of 6 PT 100 resistance thermometers in stator winding ²⁾	A61	✓	✓	✓	✓
Installation of 2 PT 100 screw-in resistance thermometers (basic circuit) for rolling-contact bearings	A72	✓	✓	✓	✓
Motor connection and connection box					
Two-part plate on connection box	K06	O. R.	O. R.	O. R.	O. R.
Undrilled entry plate	L01	○ ³⁾	○	○	○
Connection box on RHS	K09	☐	☐	☐	☐
Connection box on LHS	K10	○	○	○	○
Connection box above (1XB1 634 connection box) ⁴⁾	K11	✓	✓	✓	✓
Cable gland, maximum configuration	K57	✓	✓	✓	✓
Rotation of the connection box through 90°, entry from DE	K83	○	○	○	○
Rotation of the connection box through 90°, entry from NDE	K84	○	○	○	○
Rotation of connection box through 180°	K85	○	○	○	○
Larger connection box (1XB1 621 connection box)	M58	✓	☐ ⁵⁾	–	–
Larger connection box (1XB1 631 connection box)	L00	✓	✓ ⁵⁾	☐	☐
6 cables protruding, 1.5 m long	L48	O. R.	O. R.	O. R.	O. R.
6 cables protruding, 3 m long	L49	O. R.	O. R.	O. R.	O. R.
Auxiliary connection box 1XB9 016 (cast-iron)	M50	✓	✓	✓	✓
Auxiliary connection box 1XB3 020	L97	✓	✓	✓	✓
Auxiliary connection box 1XB9 014 (aluminum)	M88	✓	✓	✓	✓
Connection box on NDE	M64	✓	✓	✓	✓

For legend and footnotes, see Page 3/57.

IEC Squirrel-Cage Motors

Non-standard motors frame size 315 and above

Special versions

Special versions	Additional identification code -Z with order code and plain text if required	Motor type frame size			
		315	355	400	450
Forced-air cooled motors with mounted separately driven fan for converter-fed operation 1PQ8					
1PQ8 Converter-fed operation					
Windings and insulation					
Temperature class 180 (H), used acc. to 155 (F), with service factor (SF 1.1) ⁶⁾	C14	✓	✓	✓	✓
Colors and paint finish					
Standard finish in RAL 7030 stone gray		□	□	□	□
Standard paint finish in other colors	Y53 • and standard finish RAL	✓	✓	✓	✓
Special finish in RAL 7030 stone gray	K26	✓	✓	✓	✓
Special finish in other colors	Y54 • and special finish RAL	✓	✓	✓	✓
Unpainted (only cast-iron parts primed)	K23	○	○	○	○
Special technology					
Mounting of brake (incl. brake of Stromag)	H47	O. R.	O. R.	O. R.	O. R.
Mounting of LL 861 900 220 rotary pulse encoder	H70	✓	✓	✓	✓
Mounting of HOG 10 D 1024 I rotary pulse encoder	H73	✓	✓	✓	✓
Prepared for mounting LL 861 900 220	H78	✓	✓	✓	✓
Prepared for mounting HOG 10 D 1024 I	H80	✓	✓	✓	✓
Mounting a special type of rotary pulse encoder	Y70 • and encoder designation	O. R.	O. R.	O. R.	O. R.
Mechanical design and degrees of protection					
Low-noise version for 2-pole motors with clockwise direction of rotation	K37	–	–	–	–
Low-noise version for 2-pole motors with counter-clockwise direction of rotation	K38	–	–	–	–
IP56 degree of protection (non-heavy-sea)	K52	O. R.	O. R.	O. R.	O. R.
Non-rusting screws (externally) ⁷⁾	M27	✓	✓	✓	✓
Coolant temperature and site altitude					
Coolant temperature –40 to +40 °C	D03	O. R.	O. R.	O. R.	O. R.
Coolant temperature –30 to +40 °C	D04	O. R.	O. R.	O. R.	O. R.
Coolant temperature 45 °C, derating 4 % ⁸⁾	D11	○	○	○	○
Coolant temperature 50 °C, derating 8 % ⁸⁾	D12	○	○	○	○
Coolant temperature 55 °C, derating 13 % ⁸⁾	D13	○	○	○	○
Coolant temperature 60 °C, derating 18 % ⁸⁾	D14	○	○	○	○

IEC Squirrel-Cage Motors

Non-standard motors frame size 315 and above

Special versions

Special versions	Additional identification code -Z with order code and plain text if required	Motor type frame size			
		315	355	400	450
Forced-air cooled motors with mounted separately driven fan for converter-fed operation 1PQ8					
1PQ8					
Converter-fed operation					
Designs in accordance with standards and specifications					
Electrical according to NEMA MG1-12 ⁹⁾	D30	✓	✓	✓	✓
Design according to UL with "Recognition Mark"	D31	✓	✓	✓	✓
Canadian regulations (CSA)	D40	✓	✓	✓	✓
Design for Zones 2 and 22 according to ATEX¹⁰⁾					
Design for Zone 2 for mains-fed operation Ex nA II T3 to IEC/EN 60079-15	M72	–	–	–	–
Design for Zone 2 for converter-fed operation, reduced output Ex nA II T3 to IEC/EN 60079-15 ^{11) 12) 13)}	M73	O. R.	O. R.	O. R.	O. R.
Design for Zone 22 for non-conducting dust (IP55) for mains-fed operation	M35	–	–	–	–
Design for Zone 22 for non-conducting dust (IP55) for converter-fed operation	M39	–	–	–	–
VIK version	K30	–	–	–	–
Stamping of Ex nA II on VIK rating plate	C27	–	–	–	–
Bearings and lubrication					
Measuring nipple for SPM shock pulse measurement for bearing inspection	G50	✓	✓	✓	✓
Bearing design for increased cantilever forces ¹⁴⁾	K20	✓	✓	–	–
Balance and vibration quantity					
Vibration quantity level B	K02	✓	✓	✓	✓
Full key balancing	L68	✓	✓	✓	✓
Shaft and rotor					
Second standard shaft extension	K16	–	–	–	–
Shaft extension with standard dimensions, without featherkey way	K42	✓	✓	✓	✓
Non-standard cylindrical shaft extension	Y55 • and identification code	✓	✓	✓	✓
Heating and ventilation					
Anti-condensation heaters for 230 V	K45	✓	✓	✓	✓
Anti-condensation heaters for 115 V	K46	✓	✓	✓	✓
Separately driven fan with non-standard voltage and/or frequency ¹⁵⁾	Y81 • and identification code	✓	✓	✓	✓
Rating plate and extra rating plates					
Second rating plate, loose	K31	✓	✓	✓	✓
Extra rating plate or rating plate with deviating rating plate data	Y80 • and identification code	✓	✓	✓	✓
Extra rating plate with identification code	Y82 • and identification code	✓	✓	✓	✓
Packaging, safety notes, documentation and test certificates¹⁶⁾					
Document – Electrical data sheet	B31	✓	✓	✓	✓
Document – Order dimension drawing	B32	✓	✓	✓	✓

For legend and footnotes, see Page 3/57.

IEC Squirrel-Cage Motors

Non-standard motors frame size 315 and above

Special versions

Special versions	Additional identification code -Z with order code and plain text if required	Motor type frame size			
		315	355	400	450
Forced-air cooled motors with mounted separately driven fan for converter-fed operation 1PQ8					
1PQ8 Converter-fed operation					
Packaging, safety notes, documentation and test certificates ¹⁶⁾ (continued)					
Document – Load characteristics	B37	O. R.	O. R.	O. R.	O. R.
Normal inspection (routine inspection) with acceptance	F01	✓	✓	✓	✓
Visual acceptance and report handover with acceptance	F03	✓	✓	✓	✓
Temperature-rise test, without acceptance	F04	✓	✓	✓	✓
Temperature-rise test, with acceptance	F05	✓	✓	✓	✓
Noise measurement in no-load operation, no noise analysis, no acceptance	F28	✓	✓	✓	✓
Noise measurement in no-load operation, no noise analysis, with acceptance	F29	✓	✓	✓	✓
Noise measurement in no-load operation, with noise analysis, without acceptance	F62	✓	✓	✓	✓
Noise measurement in no-load operation, with noise analysis, with acceptance	F63	✓	✓	✓	✓
Recording of current and torque curves with torque metering shaft during starting, without acceptance	F34	–	–	–	–
Recording of current and torque curves with torque metering shaft during starting, with acceptance	F35	–	–	–	–
Measurement of locked-rotor torque and current, without acceptance	F52	–	–	–	–
Measurement of locked-rotor torque and current, with acceptance	F53	–	–	–	–
Type test with heat run for horizontal motors, without acceptance	F82	✓	✓	✓	✓
Type test with heat run for horizontal motors, with acceptance	F83	✓	✓	✓	✓
Type test with heat run for vertical motors, without acceptance	F92	✓	✓	✓	✓
Type test with heat run for vertical motors, with acceptance	F93	✓	✓	✓	✓

- Standard version
- Without additional charge
- This order code only determines the price of the version – Additional plain text is required.
- O. R. Possible on request
- ✓ With additional charge
- Not possible

¹⁾ Evaluation with appropriate tripping unit (see Catalog LV 1) is recommended.

²⁾ The standard thermistors are omitted. If PTC thermistors are required as well as KTYs or PT100s, this must be specified in the order in plain text. A combination of **A12** and **A61** or **A12** and **A23** is possible on request for an additional charge.

³⁾ Only possible in combination with the larger connection boxes 1XB1 621 or 1XB1 631 (order codes **M58** or **L00**).

⁴⁾ A combination with the order codes **M88** and **M50** is not possible. Connection box 1XP1 634 can be rotated through 4 x 90°. Cable entry is from NDE or the delivery position. Dimension drawings available on request.

⁵⁾ With 1PQ8 357-2 and 1PQ8 357-4, connection box 1XB1 631 is supplied in the standard version.

⁶⁾ Use according to temperature class 180 (H) is not possible. All 400 V version are available on request. Due to the rated current, a larger connection box of type 1XB9 600, which is part of order code **C14**, is generally provided for frame sizes 400 (2- and 4-pole) and 450 (all no. of poles).

⁷⁾ Only possible for main motor – Not possible for separately driven fan.

⁸⁾ Site altitude up to 1000 m above sea level.

⁹⁾ Only possible for main motor – Not possible for separately driven fan motor.

¹⁰⁾ Explosion-protected encoders are available on request.

¹¹⁾ Only admissible for use in accordance with temperature class 130 (B). PTC thermistors for temperature class 130 (B) are included. For compliance with temperature class 130 (B), derating is necessary in the case of converter-fed operation in Zones 2 and 22. Derating data are available on request.

¹²⁾ These motors do not have a rated voltage range stamped on the rating plate.

¹³⁾ In the order, the "Speed range and torque characteristic" must be specified in plain text. A system test is necessary for $M = \text{constant}$.

¹⁴⁾ Not possible for 2-pole motors and motors of vertical type of construction.

¹⁵⁾ When ordering, specify in plain text: Voltage, frequency and circuit.

¹⁶⁾ Type testing is also performed for converter-fed operation.

IEC Squirrel-Cage Motors

Non-standard motors frame size 315 and above

Special versions

Options or order codes (supplement **-Z** is required)

Special versions	Additional identification code -Z with order code and plain text if required	Motor type frame size							
		315	355	400	450	315	355	400	450
Self-ventilated motors with through ventilation for mains-fed and converter-fed operation									
		1LL8 Mains-fed operation				1LL8 Converter-fed operation			
Standardline									
Standardline version	B20	–	–	–	–	–	–	–	–
Motor protection									
Motor protection with PTC thermistors with 6 embedded temperature sensors for alarm and tripping ¹⁾	A12	☐	☐	☐	☐	☐	☐	☐	☐
Motor temperature detection with embedded temperature sensor KTY 84-130 ²⁾	A23	○	○	○	○	○	○	○	○
Installation of 6 PT 100 resistance thermometers in stator winding ²⁾	A61	✓	✓	✓	✓	✓	✓	✓	✓
Installation of 2 PT 100 screw-in resistance thermometers (basic circuit) for rolling-contact bearings	A72	✓	✓	✓	✓	✓	✓	✓	✓
Motor connection and connection box									
Two-part plate on connection box	K06	✓	✓	✓	✓	O. R.	O. R.	O. R.	O. R.
Undrilled entry plate	L01	○	○	○	○	○	○	○	○
Connection box on RHS	K09	☐	☐	☐	☐	☐	☐	☐	☐
Connection box on LHS	K10	○	○	○	○	○	○	○	○
Connection box above (1XB1 634 connection box) ³⁾	K11	✓	✓	✓	✓	✓	✓	✓	✓
Cable gland, maximum configuration	K57	✓	✓	✓	✓	✓	✓	✓	✓
Rotation of the connection box through 90°, entry from DE	K83	○	○	○	○	○	○	○	○
Rotation of the connection box through 90°, entry from NDE	K84	○	○	○	○	○	○	○	○
Rotation of connection box through 180°	K85	○	○	○	○	○	○	○	○
Larger connection box (1XB1 621 connection box)	M58	✓	–	–	–	☐	–	–	–
Larger connection box (1XB1 631 connection box)	L00	✓	☐	☐	☐	✓	☐	☐	☐
6 cables protruding, 1.5 m long	L48	O. R.	O. R.	O. R.	O. R.	O. R.	O. R.	O. R.	O. R.
6 cables protruding, 3 m long	L49	O. R.	O. R.	O. R.	O. R.	O. R.	O. R.	O. R.	O. R.
Auxiliary connection box 1XB9 016 (cast-iron)	M50	✓	✓	✓	✓	✓	✓	✓	✓
Auxiliary connection box 1XB3 020	L97	✓	✓	✓	✓	✓	✓	✓	✓
Auxiliary connection box 1XB9 014 (aluminum)	M88	✓	✓	✓	✓	✓	✓	✓	✓
Connection box on NDE	M64	✓	✓	✓	✓	✓	✓	✓	✓

For legend and footnotes, see Page 3/61.

IEC Squirrel-Cage Motors

Non-standard motors frame size 315 and above

Special versions

Special versions	Additional identification code -Z with order code and plain text if required	Motor type frame size								
		315	355	400	450	315	355	400	450	
Self-ventilated motors with through ventilation for mains-fed and converter-fed operation										
			1LL8 Mains-fed operation				1LL8 Converter-fed operation			
Windings and insulation										
Temperature class 155 (F), used acc. to 155 (F), with service factor (SF 1.1, SF 1.05 from frame size 400) ⁴⁾	C11	✓	✓	✓	✓	–	–	–	–	
Temperature class 155 (F), used acc. to 155 (F), with increased output (10 %, 5 % from frame size 400) ⁴⁾	C12	✓	✓	✓	✓	–	–	–	–	
Temperature class 155 (F), used acc. to 155 (F), with increased coolant temperature (55 °C, 50 °C from frame size 400) ⁴⁾	C13	✓	✓	✓	✓	–	–	–	–	
Temperature class 180 (H), used acc. to 155 (F), with service factor (SF 1.1)	C14	O. R.	O. R.	O. R.	O. R.	O. R.	O. R.	O. R.	O. R.	
Colors and paint finish										
Standard finish in RAL 7030 stone gray		□	□	□	□	□	□	□	□	
Standard paint finish in other colors	Y53 • and standard finish RAL	✓	✓	✓	✓	✓	✓	✓	✓	
Special finish in RAL 7030 stone gray	K26	✓	✓	✓	✓	✓	✓	✓	✓	
Special finish in other colors	Y54 • and special finish RAL	✓	✓	✓	✓	✓	✓	✓	✓	
Unpainted (only cast iron parts primed)	K23	○	○	○	○	○	○	○	○	
Special technology										
Mounting of brake (incl. brake of Stromag)	H47	–	–	–	–	–	–	–	–	
Mounting of LL 861 900 220 rotary pulse encoder	H70	–	–	–	–	✓	✓	✓	✓	
Mounting of HOG 10 D 1024 I rotary pulse encoder	H73	–	–	–	–	✓	✓	✓	✓	
Prepared for mounting LL 861 900 220	H78	–	–	–	–	✓	✓	✓	✓	
Prepared for mounting HOG 10 D 1024 I	H80	–	–	–	–	✓	✓	✓	✓	
Mounting a special type of rotary pulse encoder	Y70 • and encoder designation	–	–	–	–	O. R.	O. R.	O. R.	O. R.	
Mechanical design and degrees of protection										
Low-noise version for 2-pole motors with clockwise direction of rotation	K37	✓	○	○	○	✓	○	○	○	
Low-noise version for 2-pole motors with counter-clockwise direction of rotation	K38	✓	○	○	○	✓	○	○	○	
IP56 degree of protection (non-heavy-sea)	K52	–	–	–	–	–	–	–	–	
Non-rusting screws (externally)	M27	✓	✓	✓	✓	✓	✓	✓	✓	
Coolant temperature and site altitude										
Coolant temperature –40 to +40 °C	D03	–	–	–	–	–	–	–	–	
Coolant temperature –30 to +40 °C	D04	–	–	–	–	–	–	–	–	
Coolant temperature 45 °C, derating 4 % ⁵⁾	D11	○	○	○	○	○	○	○	○	
Coolant temperature 50 °C, derating 8 % ⁵⁾	D12	○	○	○	○	○	○	○	○	
Coolant temperature 55 °C, derating 13 % ⁵⁾	D13	○	○	○	○	○	○	○	○	
Coolant temperature 60 °C, derating 18 % ⁵⁾	D14	○	○	○	○	○	○	○	○	

For legend and footnotes, see Page 3/61.

IEC Squirrel-Cage Motors

Non-standard motors frame size 315 and above

Special versions

Special versions	Additional identification code -Z with order code and plain text if required	Motor type frame size							
		315	355	400	450	315	355	400	450
Self-ventilated motors with through ventilation for mains-fed and converter-fed operation									
		1LL8 Mains-fed operation				1LL8 Converter-fed operation			
Design in accordance with standards and specifications									
Electrical according to NEMA MG1-12	D30	✓	✓	✓	✓	✓	✓	✓	✓
Design according to UL with "Recognition Mark"	D31	✓	✓	✓	✓	✓	✓	✓	✓
VIK version	K30	–	–	–	–	–	–	–	–
Canadian regulations (CSA)	D40	✓	✓	✓	✓	✓	✓	✓	✓
Designs for Zones 2 and 22 according to ATEX									
Design for Zone 2 for mains-fed operation Ex nA II T3 to IEC/EN 60079-15	M72	–	–	–	–	–	–	–	–
Design for Zone 2 for converter-fed operation, derating Ex nA II T3 to IEC/EN 60079-15	M73	–	–	–	–	–	–	–	–
Design for Zone 22 for non-conducting dust (IP55) for mains-fed operation	M35	–	–	–	–	–	–	–	–
Design for Zone 22 for non-conducting dust (IP55) for converter-fed operation	M39	–	–	–	–	–	–	–	–
Stamping of Ex nA II on VIK rating plate	C27	–	–	–	–	–	–	–	–
Bearings and lubrication									
Measuring nipple for SPM shock pulse measurement for bearing inspection	G50	✓	✓	✓	✓	✓	✓	✓	✓
Bearing design for increased cantilever forces	K20	–	–	–	–	–	–	–	–
Balance and vibration quantity									
Vibration quantity level B	K02	✓	✓	✓	✓	✓	✓	✓	✓
Full key balancing	L68	✓	✓	✓	✓	✓	✓	✓	✓
Shaft and rotor									
Second standard shaft extension ^{b)}	K16	✓	✓	✓	✓	✓	✓	✓	✓
Shaft extension with standard dimensions, without featherkey way	K42	✓	✓	✓	✓	✓	✓	✓	✓
Non-standard cylindrical shaft extension	Y55 • and identification code	✓	✓	✓	✓	✓	✓	✓	✓
Heating and ventilation									
Metal external fan	K35	✓	✓	✓	✓	✓	✓	✓	✓
Anti-condensation heaters for 230 V	K45	✓	✓	✓	✓	✓	✓	✓	✓
Anti-condensation heaters for 115 V	K46	✓	✓	✓	✓	✓	✓	✓	✓
Sheet metal fan cover	L36	□	□	□	□	□	□	□	□
Rating plate and extra rating plates									
Second rating plate, loose	K31	✓	✓	✓	✓	✓	✓	✓	✓
Extra rating plate or rating plate with deviating rating plate data	Y80 • and identification code	✓	✓	✓	✓	✓	✓	✓	✓
Extra rating plate with identification code	Y82 • and identification code	✓	✓	✓	✓	✓	✓	✓	✓
Packaging, safety notes, documentation and test certificates ⁷⁾									
Document – Electrical data sheet	B31	✓	✓	✓	✓	✓	✓	✓	✓
Document – Order dimension drawing	B32	✓	✓	✓	✓	✓	✓	✓	✓
Document – Load characteristics	B37	O. R.	O. R.	O. R.	O. R.	O. R.	O. R.	O. R.	O. R.

For legend and footnotes, see Page 3/61.

IEC Squirrel-Cage Motors

Non-standard motors frame size 315 and above

Special versions

Special versions	Additional identification code -Z with order code and plain text if required	Motor type frame size							
		315	355	400	450	315	355	400	450
Self-ventilated motors with through ventilation for mains-fed and converter-fed operation									
		1LL8 Mains-fed operation				1LL8 Converter-fed operation			
Packaging, safety notes, documentation and test certificates ⁷⁾ (continued)									
Standard test (routine test) with acceptance	F01	✓	✓	✓	✓	✓	✓	✓	✓
Visual acceptance and report handover with acceptance	F03	✓	✓	✓	✓	✓	✓	✓	✓
Temperature-rise test, without acceptance	F04	✓	✓	✓	✓	✓	✓	✓	✓
Temperature-rise test, with acceptance	F05	✓	✓	✓	✓	✓	✓	✓	✓
Noise measurement in no-load operation, no noise analysis, no acceptance	F28	✓	✓	✓	✓	✓	✓	✓	✓
Noise measurement in no-load operation, no noise analysis, with acceptance	F29	✓	✓	✓	✓	✓	✓	✓	✓
Noise measurement in no-load operation, with noise analysis, without acceptance	F62	✓	✓	✓	✓	✓	✓	✓	✓
Noise measurement in no-load operation, with noise analysis, with acceptance	F63	✓	✓	✓	✓	✓	✓	✓	✓
Recording of current and torque curves with torque metering shaft during starting, without acceptance	F34	✓	✓	✓	✓	–	–	–	–
Recording of current and torque curves with torque metering shaft during starting, with acceptance	F35	✓	✓	✓	✓	–	–	–	–
Measurement of locked-rotor torque and current, without acceptance	F52	✓	✓	✓	✓	–	–	–	–
Measurement of locked-rotor torque and current, with acceptance	F53	✓	✓	✓	✓	–	–	–	–
Type test with heat run for horizontal motors, without acceptance	F82	✓	✓	✓	✓	✓	✓	✓	✓
Type test with heat run for horizontal motors, with acceptance	F83	✓	✓	✓	✓	✓	✓	✓	✓
Type test with heat run for vertical motors, without acceptance	F92	✓	✓	✓	✓	✓	✓	✓	✓
Type test with heat run for vertical motors, with acceptance	F93	✓	✓	✓	✓	✓	✓	✓	✓

- Standard version
- Without additional charge
- This order code only determines the price of the version – Additional plain text is required.
- R. Possible on request
- ✓ With additional charge
- Not possible

1) Evaluation with appropriate tripping unit (see Catalog LV 1) is recommended.

2) The standard thermistors are omitted. If PTC thermistors are required as well as KTYs or PT100s, this must be specified in the order in plain text. A combination of **A12** and **A61** or **A12** and **A23** is possible on request for an additional charge.

3) A combination with the order codes **M88** and **M50** is not possible. Connection box 1XP1 634 can be rotated through 4 x 90°. Cable entry is from NDE or the delivery position. Dimension drawings available on request.

4) Use according to temperature class 180 (H) is not possible. All 400 V version are available on request. Due to the rated current, a larger connection box of type 1XB9 600, which is part of order code **C14**, is generally provided for frame sizes 400 (2- and 4-pole) and 450 (all no. of poles).

5) Site altitude 1000 m above sea level

6) Please inquire in the case of 2-pole motors and motors in vertical type of construction.

7) Type testing is also performed for converter-fed operation.

IEC Squirrel-Cage Motors

Non-standard motors frame size 315 and above

Accessories

Overview

Slide rails with fixing bolts and tensioning screws to DIN 42923

Slide rails are used to tension the belt of a machine easily and conveniently when a belt tightener is not available. They are fixed to the base using stone bolts or foundation blocks.

The assignment of slide rails to motor size can be found in DIN 42923. For motors of frame sizes 335 to 450, there are no standardized slide rails (please inquire).

Available from:

Lütgert & Co. GmbH
Postfach 42 51
33276 Gütersloh, Germany
Tel. +49 (0)5241-7407-0
Fax +49 (0)5241-7407-90

<http://www.luetgert-antriebe.de>
e-mail: info@luetgert-antriebe.de

Foundation block acc. to DIN 799

The foundation blocks are inserted into the stone foundation and embedded in concrete. They are used for fixing machines of medium size, slide rails, pedestal bearings, baseframes, etc. After the fixing bolts have been unscrewed, the machine can be dragged without it having to be lifted.

When the machine is initially installed, the foundation block that is bolted to the machine (without washers) and fitted with tapered pins is not embedded with concrete until the machine has been fully aligned. In this case, the machine is positioned 2 to 3 mm lower. The difference in shaft height is compensated by inserting shims on final installation. The tapered pins safeguard the exact position of the machine when it is repeatedly removed and replaced without the need for realignment.

Available from:

Lütgert & Co. GmbH
Postfach 42 51
33276 Gütersloh, Germany
Tel. +49 (0)5241-7407-0
Fax +49 (0)5241-7407-90

<http://www.luetgert-antriebe.de>
e-mail: info@luetgert-antriebe.de

Taper pins to DIN 258 with threaded ends and constant taper lengths

Taper pins are used for components that are repeatedly removed. The drilled hole is ground conical using a conical reamer until the pin can be pushed in by hand until the cone shoulder lies 3 to 4 mm above the rim of the hole.

It can then be driven in using a hammer until it is correctly seated. The pin is removed from the drilled hole by screwing on the nut and tightening it.

Standardized taper pins are available from general engineering suppliers.

Available from:

Otto Roth GmbH & Co. KG
Rutesheimer Straße 22
70499 Stuttgart, Germany
Tel. +49 (0)711-13 88-0
Fax +49 (0)711-13 88-233

<http://www.ottoroth.de>
e-mail: info@ottoroth.de

Couplings

The motor from Siemens is connected to the machine or gear unit through a coupling. Flender is an important coupling manufacturer with a wide range of products. For standard applications, Siemens recommends that elastic couplings of Flender types N-Eupex and Rupex or torsionally rigid couplings of types Arpex and Zapex are used. For special applications, Fludex and Elpex-S couplings are recommended. These coupling types are suitable for use in areas subject to explosion hazards and are offered with declaration of conformity and type test certificate according to directive 94/9/EU.

Source of supply:

Siemens contact partner – ordering from Catalog
Siemens MD 10.1 „FLENDER Standard Couplings“

or

A. Friedr. Flender AG
Kupplungswerk Mussum
Industriepark Bocholt
Schlavenhorst 100
46395 Bocholt, Germany
Tel. +49 (0)2871-92 2185
Fax +49 (0)2871-92 2579

<http://www.flender.com>
e-mail: couplings@flender.com

More information

Spare motors and repair parts

- Supply commitment for spare motors and repair parts following delivery of the motor
 - For up to 5 years, in the event of total motor failure, Siemens will supply a comparable motor with regard to the mounting dimensions and functions (the type series may vary).
 - Repair parts will be supplied for up to 5 years.
 - For up to 10 years, Siemens will provide information and will, if necessary, supply documentation for repair parts.
- When repair parts are ordered, the following details must be provided:
 - Designation and part number
 - Order No. and factory number of the motor

Example for an order for a fan cowl 1LA8, frame size 315, 4-pole:

**Fan cowl No. 12.01,
1LA8 315-4AB60, factory No. J1172515010001**

- For bearing types, see the “Introduction”.
- For standard components, a supply commitment does not apply.
- Support – Hotline
In Germany
Tel.: 01 80/5 05 04 48

You will find telephone numbers for other countries on our Internet site:

<http://www.siemens.com/automation/service&support>

IEC Squirrel-Cage Motors

Non-standard motors frame size 315 and above

Dimensions

Overview

Overall dimensions

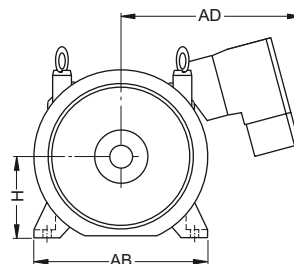
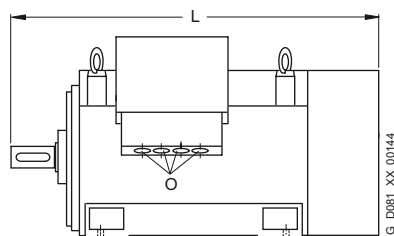

Frame size	Type	Number of poles	Dimensions			
			L	AD	H	AB
315	1LA8	2	1380	570	315	680
	1LA8	4, 6, 8	1410	570	315	680
	1LA8	4, 6, 8 ¹⁾	1430	570	315	680
	1PQ8	2	1742	570	315	680
	1PQ8	4, 6, 8	1772	570	315	680
	1PQ8	4 ¹⁾	1792	570	315	680
	1LL8	2	1380	662	315	680
	1LL8	4, 6, 8	1410	662	315	680
355	1LA8	2	1605	710	355	780
	1LA8	4, 6, 8	1635	710	355	780
	1LA8	4, 6, 8 ¹⁾	1699	710	355	780
	1PQ8	2	1971	690	355	780
	1PQ8	4, 6, 8	2001	690	355	780
	1PQ8	4, 6, 8 ¹⁾	2065	690	355	780
	1LL8	2	1635	840	355	780
	1LL8	4, 6, 8	1675	840	355	780

Frame size	Type	Number of poles	Dimensions			
			L	AD	H	AB
400	1LA8	2	1793	865	400	860
	1LA8	4, 6, 8	1833	865	400	860
	1PQ8	2	2148	865	400	860
	1PQ8	4, 6, 8	2188	865	400	860
	1LL8	2	1793	865	400	860
	1LL8	4, 6, 8	1833	865	400	860
450	1LA8	2	1953	900	450	980
	1LA8	4, 6, 8	1993	900	450	980
	1PQ8	2	2308	900	450	980
	1PQ8	4, 6, 8	2348	900	450	980
	1LL8	2	1953	900	450	980
	1LL8	4, 6, 8	2033	900	450	980

For dimension "O", see "Introduction" under "Connection boxes".

Notes on the dimensions

■ Dimension drawings according to DIN EN 50347 and IEC 60072.

■ Fits

The shaft extensions specified in the dimension tables (DIN 748) and centering spigot diameters (DIN EN 50347) are machined with the following fits:

Dimension designation	ISO fit	DIN ISO 286-2
D, DA	over 50	m6
N	over 250	h6
F, FA		h9
K		H17
S	Flange (FF)	H17

The drilled holes of couplings and belt pulleys should have an ISO fit of at least H7.

■ Dimension tolerances

For the following dimensions, the permissible deviations are given below:

Dimension designation	Dimension	Permitted deviation
H	over 250	- 1.0
E, EA		- 0.5

Keyways and feather keyways (dimensions GA, GC, F and FA) are made in compliance with DIN 6885 Part 1.

■ All dimensions are specified in mm.

¹⁾ With bearings for increased cantilever forces: Dimensions available on request.

IEC Squirrel-Cage Motors

Non-standard motors frame size 315 and above

Dimensions

Dimensional drawings

Cast-iron series 1LA8, frame sizes 315 to 450

Type of construction IM B3

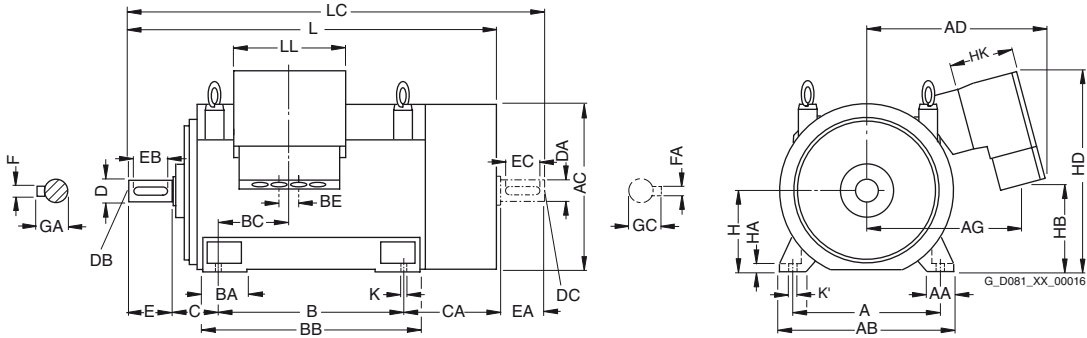

Type of construction IM V1

For flange dimensions, see Page 3/70 (Z = the number of retaining holes)

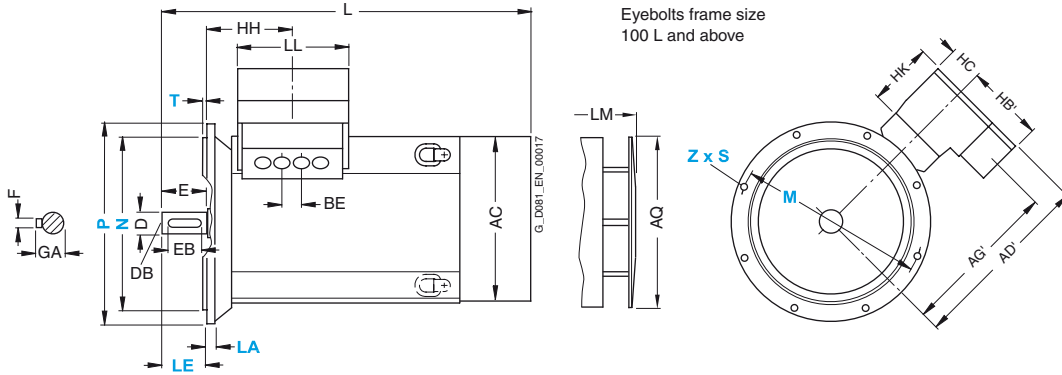

Connection box position

Version	Cable entry	Console	Order code
Basic version	bottom	0 degrees	-
Special versions	top	180 degrees	K85
	top	0 degrees	plain text

With cable entry from above, protection against rain and other adverse weather conditions must be provided.

For motor			Dimension designation acc. to IEC																				
Frame size	Type	Number of poles	A	AA	AB	AC ¹⁾	AD	AD'	AG	AG'	AQ	B	BA	BB	BC	BE	C	CA	H	HA	HB	HB'	HC
315	1LA8 31	2 4, 6, 8 4, 6, 8 ²⁾	560	120	680	710	570	582	474	481	670	630	180	780	195	140	180 180 200	435	315	28	404	217	162
355	1LA8 35	2 4, 6, 8	630	150	780	790	690	697	597	593	750	800	220	980	185	135	200 200	470	355	35	431	290	165
	1LA8 357	2, 4					829	875	739	745						100	200				359	395	175
	1LA8 35	4, 6, 8 ²⁾					690	697	597	593						135	224				431	290	165
400	1LA8 40	2 4, 6, 8	710	150	860	880	865	925	775	795	850	900	220	1080	186	100	224	506	400	35	439	395	175
450	1LA8 45	2 ³⁾ 4, 6, 8	800	180	980	970	900	975	810	845	950	1000	260	1220	170	100	250	540	450	42	525	395	175

¹⁾ Measured across the bolt heads (not in the flattened area of the fan cowl).
²⁾ With bearings for increased cantilever forces. – No second shaft extension possible.
³⁾ Only at 50 Hz.

IEC Squirrel-Cage Motors

Non-standard motors frame size 315 and above

Dimensions
Dimensional drawings
Cast-iron series 1LA8, frame sizes 315 to 450
Type of construction IM B35

For flange dimensions, see Page 3/70 (Z = the number of retaining holes)

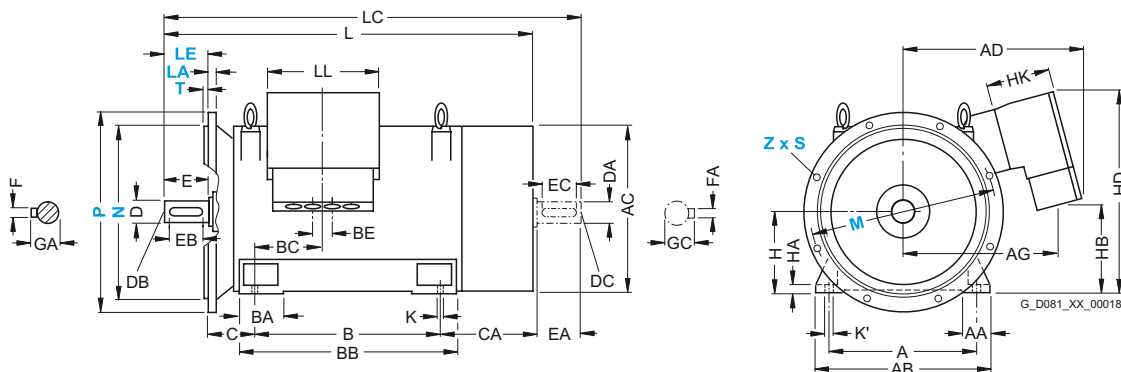
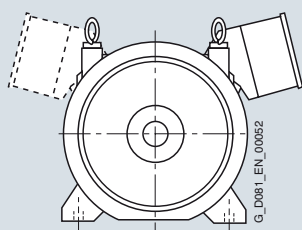
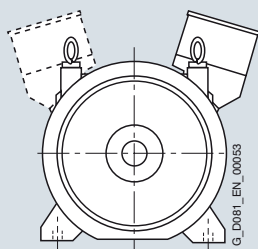
Connection box position
Special versions

 Cable entry: DE / NDE
 Console: 0 degrees
 Order code: K83/K84

 Cable entry: DE / NDE
 Console: 180 degrees
 Order code: plain text

For motor Frame size	Type	Number of poles	Dimension designation acc. to IEC								DE shaft extension					NDE shaft extension						
			HD	HK	K	K'	L	LC	LL	LM	D	DB	E	EB	F	GA	DA	DC	EA	EC	FA	GC
315	1LA8 31 .	2	783	170	26	33	1380	1495	308	1510	65	M20	140	125	18	69	50	M16	110	100	14	53.5
		4, 6, 8					1410	1555		1540	85	M20	170	140	22	90	70	M20	140	125	20	74.5
		4, 6, 8 ¹⁾					1430	1575		95	M24	170	140	25	100	-	-	-	-	-	-	-
355	1LA8 35 .	2	896	229	33	40	1605	1750	330	1745	75	M20	140	125	20	79.5	60	M20	140	125	18	64
		4, 6, 8					1635	1810		1775	95	M24	170	140	25	100	80		170	140	22	85
		2, 4					945	320				554										
	1LA8 357	2, 4	945	320					554													
	1LA8 35 .	4, 6, 8 ¹⁾					1699	-			100	M24	210	180	28	106	-	-	-	-	-	-
400	1LA8 40 .	2	1025	320	33	40	1793	1940	554	1943	80	M20	170	140	22	85	70	M20	140	125	20	74.5
		4, 6, 8					1833	2010		1983	110	M24	210	180	28	116	90	M24	170	140	25	95
450	1LA8 45 .	2 ²⁾	1111	320	39	47	1953	2100	554	2103	90	M24	170	140	25	95	75	M20	140	125	20	79.5
		4, 6, 8					1993	2210		2143	120		210	180	32	127	100	M24	210	180	28	106

¹⁾ With bearings for increased cantilever forces. – No second shaft extension possible.

²⁾ Only at 50 Hz.

IEC Squirrel-Cage Motors

Non-standard motors frame size 315 and above

Dimensions

Dimensional drawings

Cast-iron series 1PQ8, frame sizes 315 to 450

Type of construction IM B3

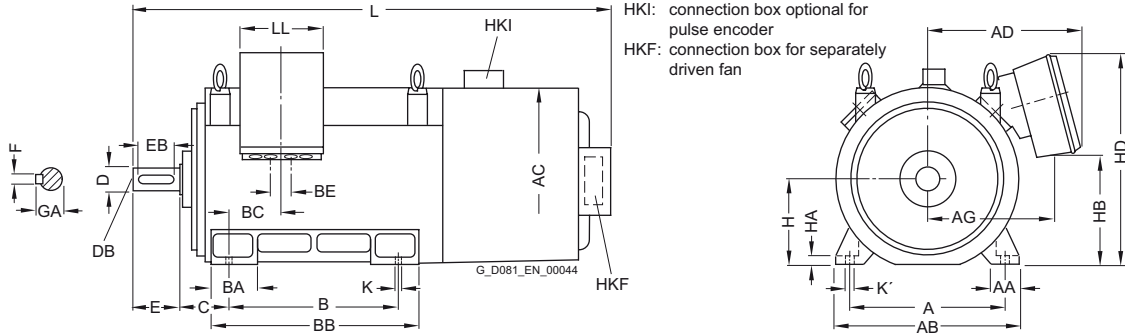

Type of construction IM V1

For flange dimensions, see Page 3/70 (Z = the number of retaining holes)

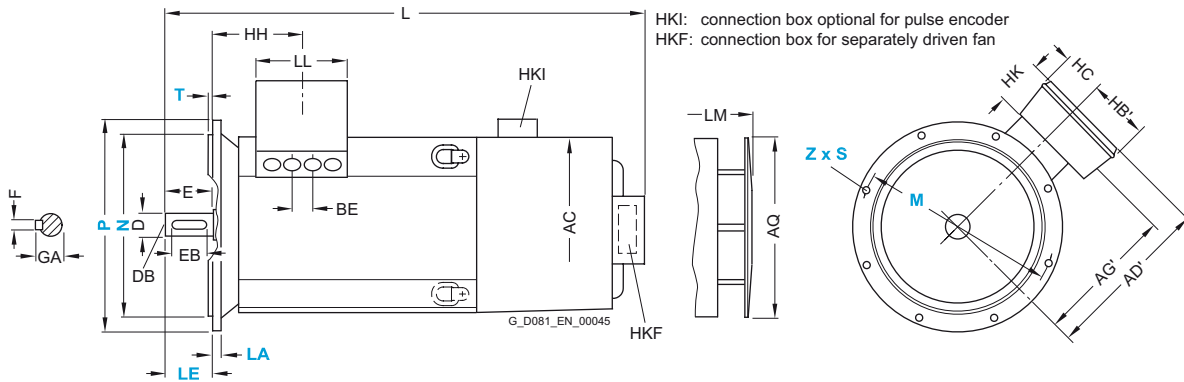

Connection box position

Basic version	Special versions	
Cable entry: bottom Console: 0 degrees Order code: -	Cable entry: top Console: 180 degrees Order code: K85	Cable entry: top Console: 0 degrees Order code: plain text

With cable entry from above, protection against rain and other adverse weather conditions must be provided.

For motor	Dimension designation acc. to IEC																	
Frame size	Type	Number of poles	A	AA	AB	AC ¹⁾	AD	AD'	AG	AG'	AQ	B	BA	BB	BC	BE	C	
315	1PQ8 31.	2	560	120	680	710	570	582	474	481	750	630	180	780	195	140	180	
		4, 6, 8															180	
		4, 6, 8 ²⁾															200	
355	1PQ835. 35.	2	630	150	780	790	690	697	597	593	850	800	220	980	185	135	200	
		4, 6, 8															200	
		2, 4															100	
	1PQ8357	2, 4					829	875	739	745						100	200	
	1PQ835	4, 6, 8 ²⁾					670	697	597	593							135	224
400	1PQ8 40.	2	710	150	860	880	865	925	775	795	950	900	220	1080	186	100	224	
450	1PQ8 45.	2 ³⁾	800	180	980	970	900	980	810	845	950	1000	260	1220	170	100	250	
		4, 6, 8																

¹⁾ Measured across the bolt heads (not in the flattened area of the fan cowl).

²⁾ With bearings for increased cantilever forces.

³⁾ Only at 50 Hz.

3

IEC Squirrel-Cage Motors

Non-standard motors frame size 315 and above

Dimensions

Dimensional drawings

Cast-iron series 1PQ8, frame sizes 315 to 450

Type of construction IM B35

For flange dimensions, see Page 3/70 (Z = the number of retaining holes)

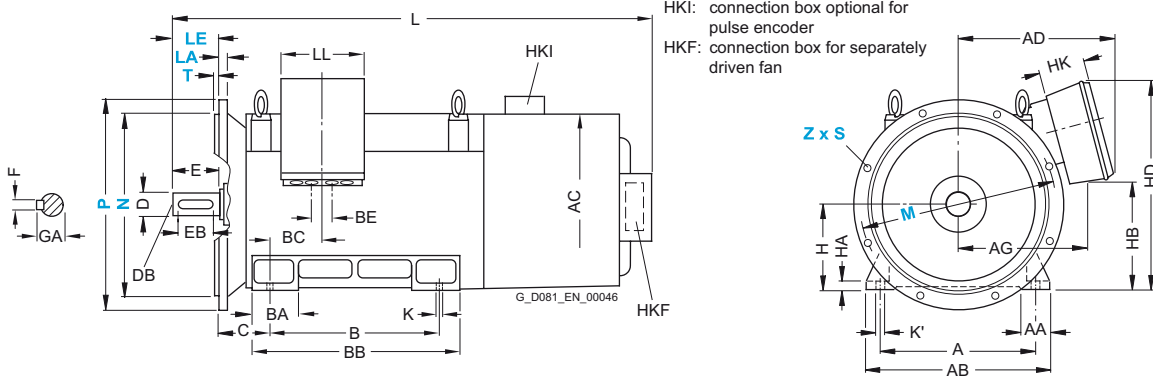

3

Connection box position

Special versions

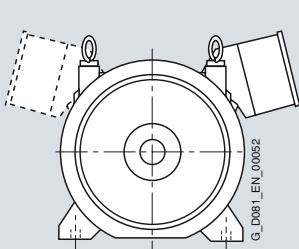

Cable entry: DE / NDE
Console: 0 degrees
Order code: K83/K84

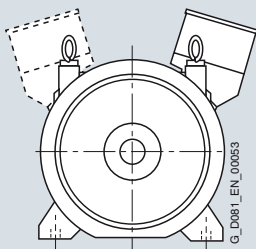

Cable entry: DE / NDE
Console: 180 degrees
Order code: plain text

For motor		Dimension designation acc. to IEC													DE shaft extension					
Frame size	Type	Number of poles	H	HA	HB	HB'	HC	HD	HK	K	K'	L	LL	LM	D	DB	E	EB	F	GA
315	1PQ8 31.	2	315	28	404	217	162	783	170	26	33	1742	308	1765	65	M20	140	125	18	69
		4, 6, 8													85	M20	170	140	22	90
		4, 6, 8 ¹⁾													95	M24	170	140	25	100
355	1PQ8 35.	2	355	35	431	290	165	896	229	33	40	1971	330	2005	75	M20	140	125	20	79.5
		4, 6, 8													95	M24	170	140	25	100
		2, 4													554					
	1PQ8 357	2, 4			359	395	175	945	320											
	1PQ8 35.	4, 6, 8 ¹⁾										2065	2099	100	M24	210	180	28	106	
400	1PQ8 40.	2	400	35	440	400	175	1025	320	33	40	2148	554	2182	80	M20	170	140	22	85
		4, 6, 8													110	M24	210	180	28	116
450	1PQ8 45.	2 ²⁾	450	42	525	400	175	1111	320	39	47	2308	554	2340	90	M24	170	140	25	95
		4, 6, 8													120		210	180	32	127

1) With bearings for increased cantilever forces.
2) Only at 50 Hz.

IEC Squirrel-Cage Motors

Non-standard motors frame size 315 and above

Dimensions

Dimensional drawings

Cast-iron series 1LL8, frame sizes 315 to 450

Type of construction IM B3

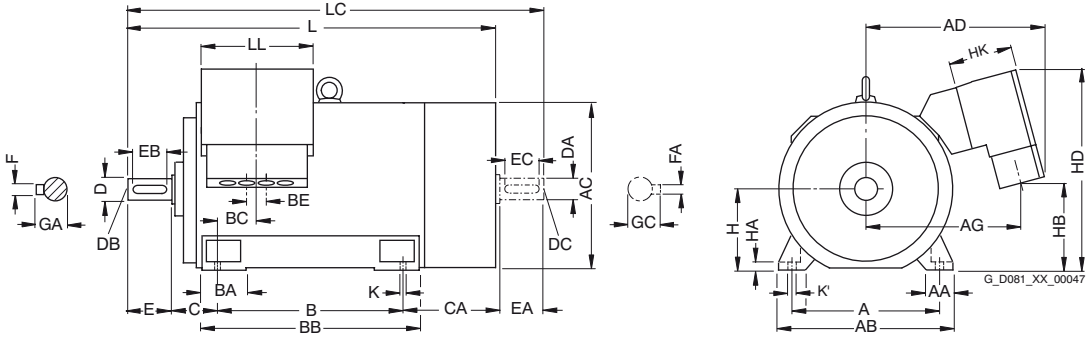

3

Connection box position

Basic version

Cable entry: bottom
Console: 0 degrees
Order code: -

Special versions

Cable entry: top
Console: 180 degrees
Order code: K85

Cable entry: top
Console: 0 degrees
Order code: plain text

For motor		Dimension designation acc. to IEC																	
Frame size	Type	Number of poles	A	AA	AB	AC ¹⁾	AD	AD'	AG	AG'	AQ	B	BA	BB	BC	BE	C	CA	
315	1LL8 31.	2 4, 6, 8	560	120	680	710	662	- 660	569	- 560	670	630	180	780	195	110	180	435	
355	1LL8 35.	2 4, 6, 8	630	150	780	790	829	- 880	739	- 745	750	800	220	980	185	135	200	470	
400	1LL8 40.	2 4, 6, 8	710	150	860	880	865	- 930	775	- 795	850	900	220	1080	186	100	224	506	
450	1LL8 45.	2 ²⁾ 4, 6, 8	800	180	980	970	900	- 980	810	- 845	950	1000	260	1220	170	100	250	540	

1) Measured across the bolt heads.

2) Only at 50 Hz.

IEC Squirrel-Cage Motors

Non-standard motors frame size 315 and above

Dimensions

Dimensional drawings

Cast-iron series 1LL8, frame sizes 315 to 450

Type of construction IM V1

For flange dimensions, see Page 3/70 (Z = the number of retaining holes)

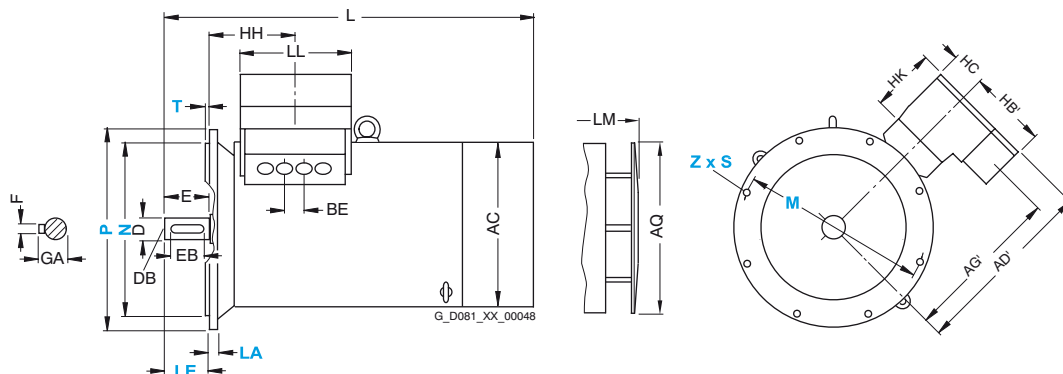

3

Connection box position

Special versions

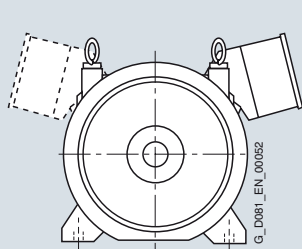

Cable entry: DE / NDE
Console: 0 degrees
Order code: K83/K84

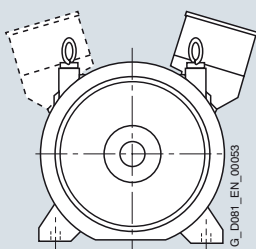

Cable entry: DE / NDE
Console: 180 degrees
Order code: plain text

For motor		Dimension designation acc. to IEC														DE shaft extension				
Frame size	Type	Number of poles	H	HA	HB	HB'	HD	HK	K	K'	L	LC	LL	LM	D	DB	E	EB	F	GA
315	1LL8 31.	2	315	28	363	–	828	229	26	33	1380	1495	330	1510	70	M20	140	125	20	74.5
		4, 6, 8				290									90	M24	170	140	25	95
355	1LL8 35.	2	355	35	359	–	945	320	33	40	1605	1750	554	1775	80	M20	170	140	22	85
		4, 6, 8				400									110	M24	210	180	28	116
400	1LL8 40.	2	400	35	439	–	1025	320	33	40	1793	1940	554	1943	85	M20	170	140	22	90
		4, 6, 8				400									120	M24	210	180	32	127
450	1LL8 45.	2 ¹⁾	450	42	525	–	1111	320	39	47	1953	2100	554	2143	90	M24	170	140	25	95
		4, 6, 8				400									130	M24	250	220	32	137

¹⁾ Only at 50 Hz.

IEC Squirrel-Cage Motors

Non-standard motors frame size 315 and above

Dimensions

Dimensional drawings

Flange dimensions

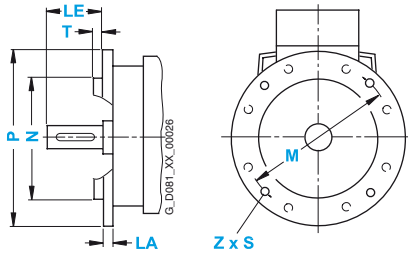

Frame size	Type of construction	Flange type	Flange with through holes (FF/A)		Dimension designation acc. to IEC							
			According to DIN EN 50347	Acc. to DIN 42948	LA	LE	M	N	P	S	T	Z
315 2-pole 4-pole to 8-pole	IM B35, IM V1	Flange	–	–	25	140 170	740	680	800	22	6	8
355 2-pole 4-pole to 8-pole	IM B35, IM V1	Flange	–	–	25	140 170	840	780	900	22	6	8
400 2-pole 4-pole to 8-pole	IM B35, IM V1	Flange	–	–	28	170 210	940	880	1000	22	6	8
450 2-pole 4-pole to 8-pole	IM B35, IM V1	Flange	–	–	30	170 210	1080	1000	1150	26	6	8