

 **SAFETY PRECAUTIONS**

1. This catalog is intended for use in selecting required servo systems. Before actually using these products, carefully read their instruction manuals and understand their correct usage.
2. Products described in this catalog are neither designed nor manufactured for combined use with a system or equipment that will affect human lives.  
If you are considering using these products for special purposes, such as atomic energy control, aerospace, medical application, or traffic control, please consult our sales office.
3. If you use our product with equipment that is expected to cause serious injury or damage to your property in case of failure, be sure to take appropriate safety measures for the equipment.

**FUJI SERVO SYSTEM**  
**ALPHA5 Smart**

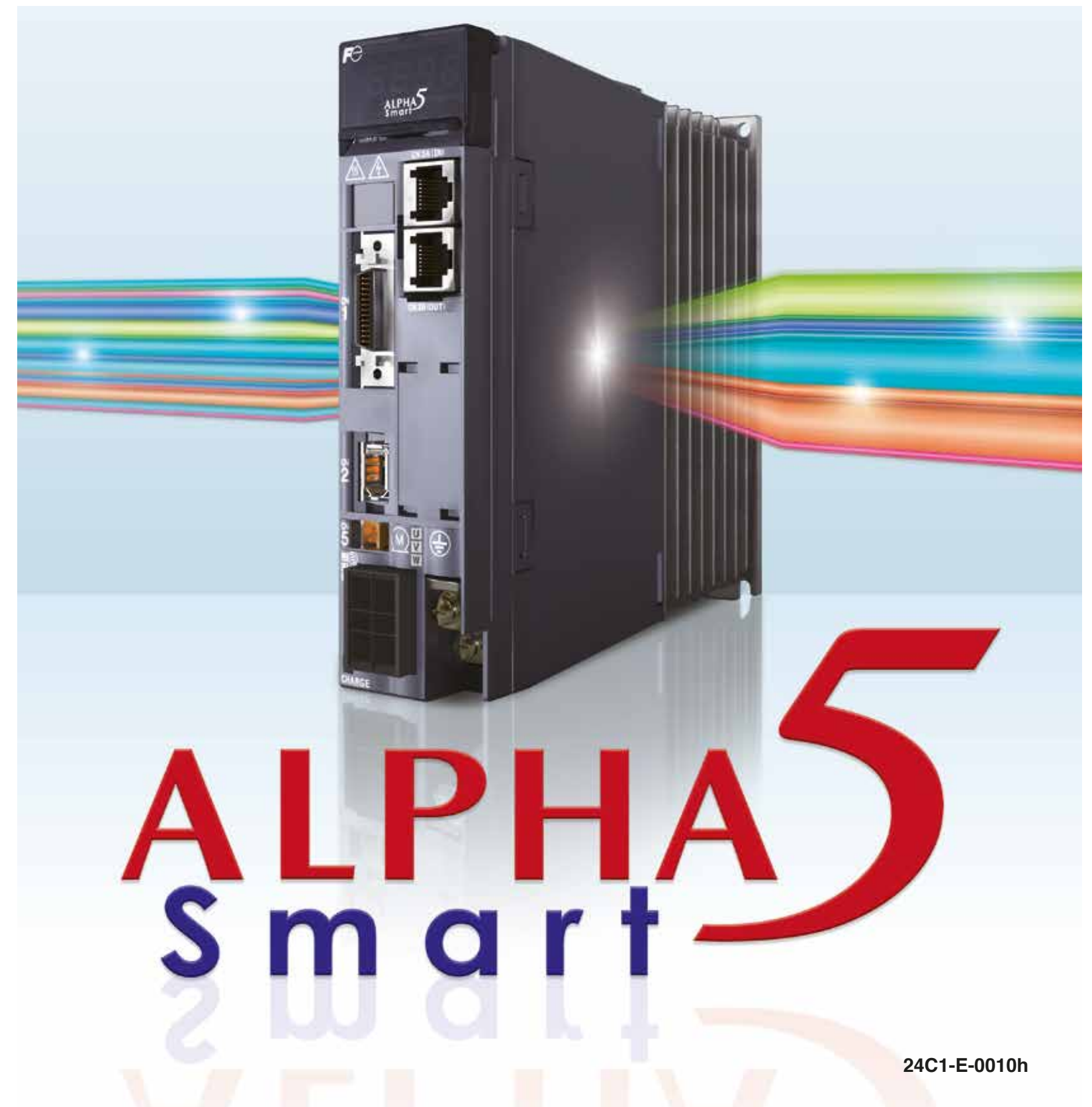

**Fuji Electric Co., Ltd.**

Gate City Ohsaki, East Tower, 11-2,  
Osaki 1-chome, Shinagawa-ku,  
Tokyo 141-0032, Japan  
Phone: +81-3-5435-7057 Fax: +81-3-5435-7420  
URL: <http://www.fujielectric.com/>

**Middle Inertia Type GYB Series Servo Motor (Rated speed 3000r/min)**

Voltage	Rated output	Motor Type (Standard)	Amplifier Type
Single or 3-phase 200V	0.2kW	GYB201D5-□□2 (-B)	RYH201F5-VV2
	0.4kW	GYB401D5-□□2 (-B)	RYH401F5-VV2
	0.75kW	GYB751D5-□□2 (-B)	RYH751F5-VV2



**NEW Middle Inertia Type GYH Series Servo Motor (Rated speed 2000r/min)**

Voltage	Rated output	Motor Type (Standard)	Amplifier Type
3-phase 200V	1.0kW	GYH102C6-TC2 (-B)	RYH751F5-VV2
	1.5kW	GYH152C6-TC2 (-B)	RYH152F5-VV2
	2.0kW	GYH202C6-TC2 (-B)	RYH152F5-VV2
	3.0kW	GYH302C6-TC2 (-B)	RYH202F5-VV2
	4.0kW	GYH402C6-TC2 (-B)	RYH302F5-VV2
	5.5kW	GYH552C6-TC2 (-B)	RYH402F5-VV2
	7.0kW	GYH702C6-TC2 (-B)	RYH502F5-VV2



Feature 1 | Wide Range of Applications

**With the new auto-tuning function, optimal tuning can be realized even for low-rigidity devices!!**



Easy adjustment even for long belt mechanisms, gears with considerable backlash, and rack and pinion mechanisms.

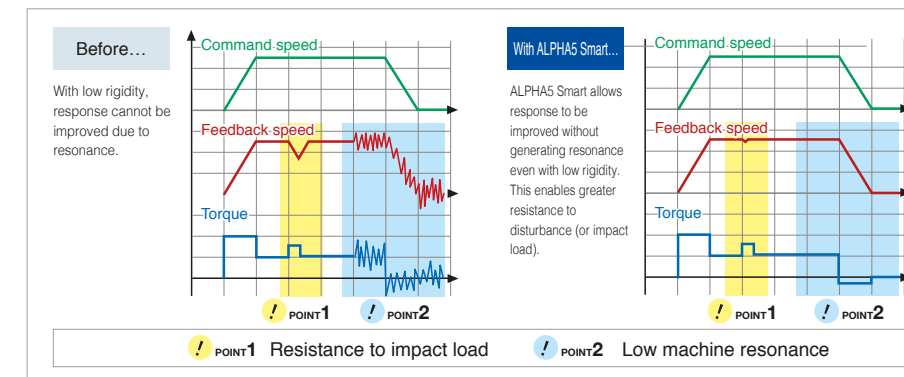

Feature 2 | Super Stability

**Smooth, stable operation even with changes due to wear or variation\* among devices.**

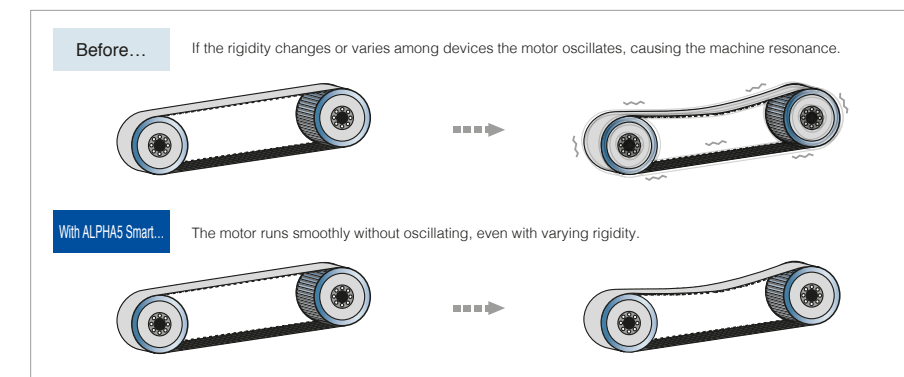

\* Variations in device rigidity such as belt tension or parts.

Other Features

**Smart Operation**

New handy-sized portable servo operator makes the operation much smarter



**Long-life design**

Electrolytic capacitor 10years

Cooling fan 10years

\* Operating conditions  
 - Ambient temperature: Average 30°C/year  
 - Load factor: Within 80%  
 - Operation rate: Within 20 hours/day

**Easy ABS battery replacement**

ABS backup battery can be mounted on front face of servo amplifier for easy replacement

**Regulatory compliance**

Global Compatibility. The standard model complies with CE marking, UL/cUL and TÜV.



**RoHS Directive**

Compliant with the European Restriction of Hazardous Substances (ROHS) Directive. The use of six hazardous substances has been reduced for a more environmentally-friendly servo system.  
 <Six hazardous materials>  
 Lead, mercury, cadmium, hexavalent chromium, polybrominated biphenyl (PBB), polybrominated diphenylether (PBDE)

Contents	
Main Products/Combination table	2
Features	3
Application Example	5
Product Family	6
Model Codes	7
Servo Amplifier Specification	8
Connection Diagram	9
Servo Motor Specifications	10
Servo amplifier External Dimensions	14
Servo Motor External Dimensions	15
Optional shaft extension specifications [with key, tapped]	19
Configuration Diagram/Peripheral Equipment	20
Options	21
Model List	23
Service Network	25
Product Warranty	26

Feature 3 | Smart Design

PTP positioning

Positioning function built in as standard

No external units or special equipment required for positioning

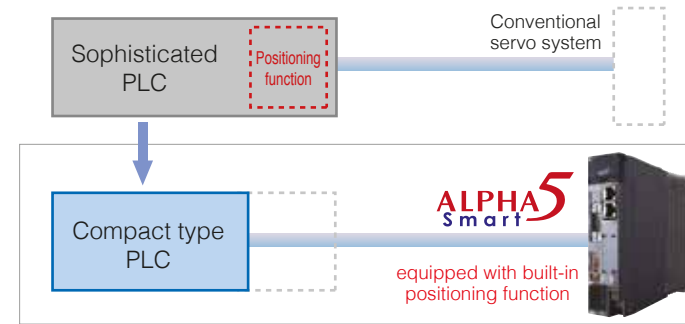

3-in-1 functionality

Three operations via one unit:

- Positioning via Modbus-RTU communications (immediate value data)
- Positioning via Di/Do signal (positioning data 15 points\*)
- Position, speed, and torque control via pulse/analog input

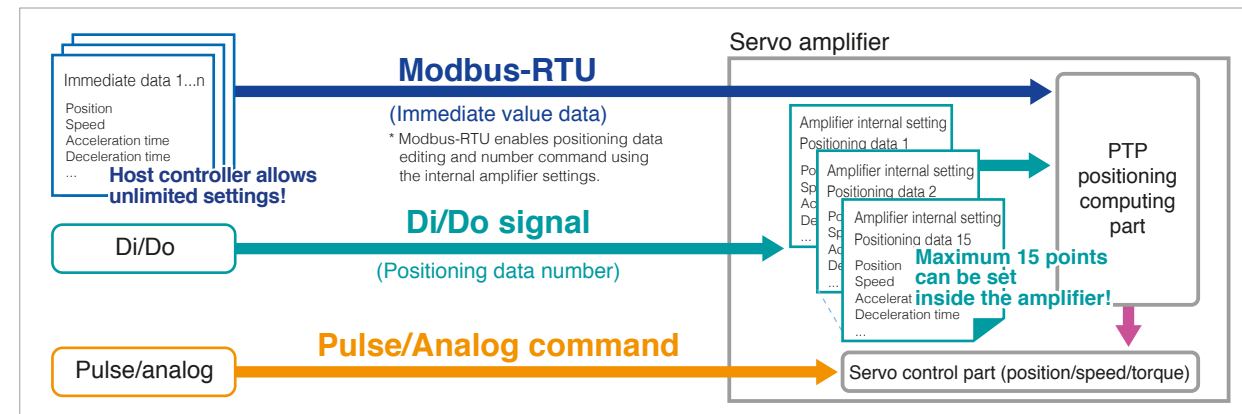

Simple operation via Modbus-RTU communications

Modbus-RTU communications enables PTP positioning, parameter editing, and the use of various monitors. Just connect an HMI, general-purpose PLC, or PC controller directly to the servo amplifier.

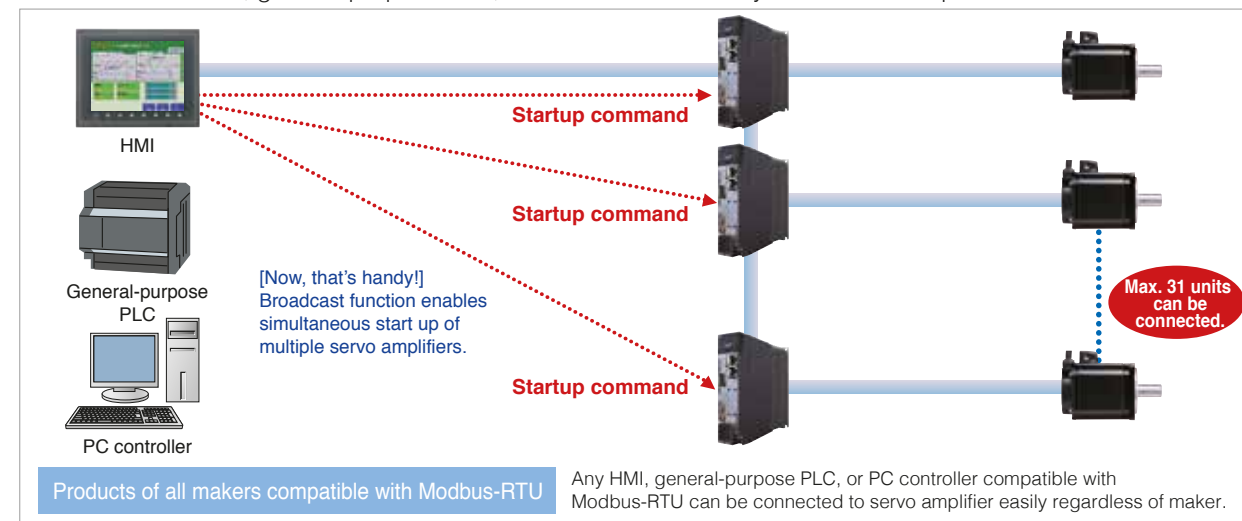

Products of all makers compatible with Modbus-RTU Any HMI, general-purpose PLC, or PC controller compatible with Modbus-RTU can be connected to servo amplifier easily regardless of maker.

Packaging Machine

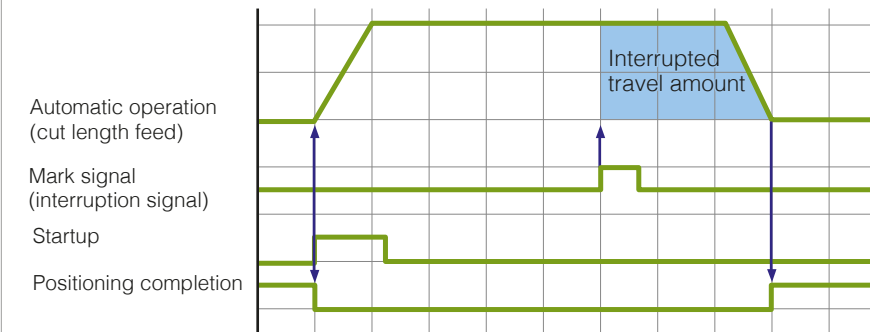
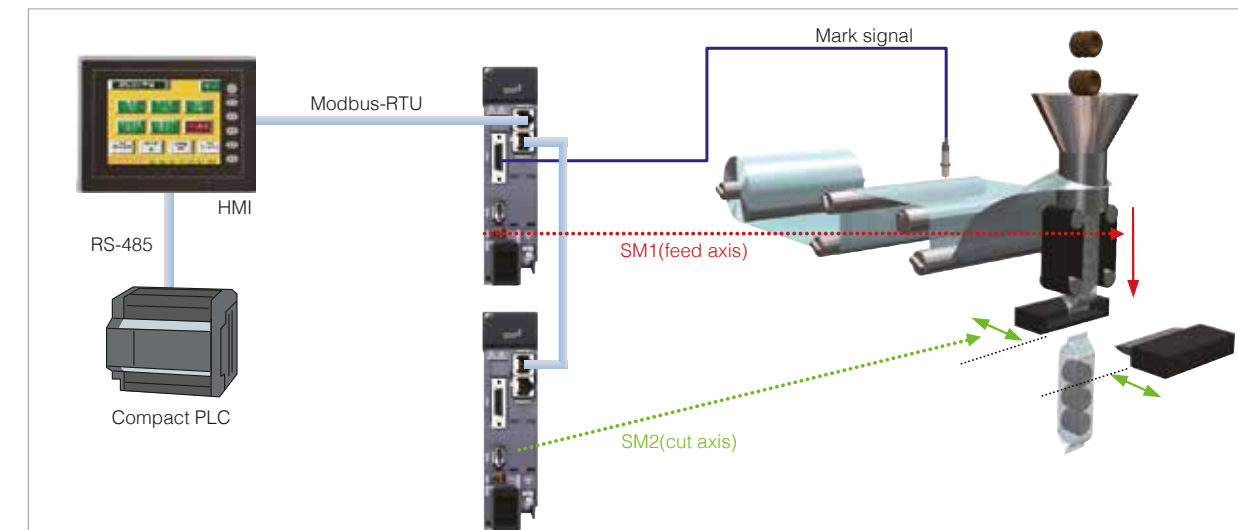

- Features**
- 1. Servo amplifier features a built-in positioning function**  
The servo amplifier's positioning data enables film feeding without the positioning controller.
  - 2. Less wiring required**  
Wiring requires fewer man-hours as basic positioning is carried out via Modbus-RTU communications.
  - 3. Interrupted positioning**  
The interrupted positioning function allows a specified amount of travel after the mark is detected for more precise mark operation.

Conveyor

Workpiece feeder, carrier, etc.

<Key Points>

- The positioning data enables positioning without a PLC.
- Enables simultaneous operation.
- Enables rapid acceleration/deceleration and high-speed operation.
- Enables high-accuracy positioning.
- High-tact operation mode allows high-frequency operation.

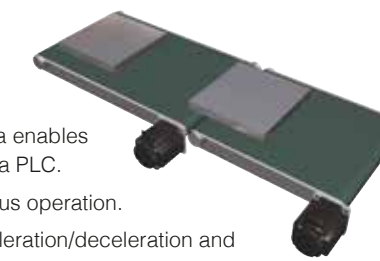

XY Table

Engraving machine, 2D positioning unit, etc.

<Key Points>

- The positioning data enables positioning without a PLC.
- Enables rapid acceleration/deceleration and high-speed operation.
- Enables high-accuracy positioning.
- Trace operation mode allows optimal operation.



### Servo Amplifier / Motor

Servo Amplifier	Applicable Motor	Middle					Ultra-low
		GYB Motor	GYH Motor	GYG Motor	GYG Motor	GYS Motor	
	Applicable motor output	3000 [r/m] Brake: without (with)	2000 [r/min] Brake: without (with)	2000 [r/min] Brake: without (with)	1500 [r/min] Brake: without (with)	3000 [r/min] Brake: without (with)	
RYH201F5-VV2	0.05kW					GYS500D5-□□2 (-B)	
	0.1kW					GYS101D5-□□2 (-B)	
RYH401F5-VV2	0.2kW	GYB201D5-□□2 (-B)				GYS201D5-□□2 (-B)	
	0.4kW	GYB401D5-□□2 (-B)				GYS401D5-□□2 (-B)	
RYH751F5-VV2	0.5kW			GYG501C5-□□2 (-B)	GYG501B5-□□2 (-B)		
	0.75kW	GYB751D5-□□2 (-B)		GYG751C5-□□2 (-B)		GYS751D5-□□2 (-B)	
	1.0kW		GYH102C6-TC2 (-B)				
RYH152F5-VV2	0.85kW				GYG851B5-□□2 (-B)		
	1.0kW			GYG102C5-□□2 (-B)		GYS102D5-□□2 (-B)	
	1.5kW		GYH152C6-TC2 (-B)	GYG152C5-□□2 (-B)		GYS152D5-□□2 (-B)	
RYH202F5-VV2	2.0kW		GYH202C6-TC2 (-B)				
	3.0kW		GYH302C6-TC2 (-B)				
RYH302F5-VV2	1.3kW				GYG132B5-□□2 (-B)		
	2.0kW			GYG202C5-□□2 (-B)		GYS202D5-□□2 (-B)	
RYH402F5-VV2	3.0kW					GYS302D5-□□2 (-B)	
	4.0kW		GYH402C6-TC2 (-B)				
RYH502F5-VV2	4.0kW					GYS402D5-□□2 (-B)	
	5.5kW		GYH552C6-TC2 (-B)				
RYH502F5-VV2	5.0kW					GYS502D5-□□2 (-B)	
	7.0kW		GYH702C6-TC2 (-B)				

### Servo Amplifier

**RYH 201 F 5 - V V 2**

Code	[Basic Type]	Code	[Input voltage]
RYH	ALPHA5 Smart series	2	3-phase 200V
Code	[Applicable Motor Output]	Code	[Upper interface]
201	20×10 <sup>1</sup> = 200W, 100W, 50W	V	General-purpose interface (pulse, analog voltage)
401	40×10 <sup>1</sup> = 400W		
751	75×10 <sup>1</sup> = 750W, 500W	Code	[Major functions]
152	15×10 <sup>2</sup> = 1.5kW, 1.0kW, 850W	V	Position, speed and torque control
202	20×10 <sup>2</sup> = 2.0kW	Code	[Development Order]
302	30×10 <sup>2</sup> = 3.0kW, 4.0kW	5	5
402	40×10 <sup>2</sup> = 4.0kW, 5.5kW		
502	50×10 <sup>2</sup> = 5.0kW, 7.0kW		
Code	[Series]		
F	1500 to 3000r/min series		

### Servo Motor

**GYB 201 D 5 - R C 2 - B**

Code	[Basic Type]	Code	[Brake]
GYB	Middle Inertia Type	Blank	Without
GYH	Middle Inertia Type	B	With
GYG	Middle Inertia Type	Code	[Input voltage]
GYS	Ultra-low Inertia Type	2	3-phase 200V
Code	[Rated Output]	Code	[Oil seal/shaft]
500	50×10 <sup>0</sup> = 50W	A	Without oil seal, straight shaft, with key
101	10×10 <sup>1</sup> = 100W	B	Without oil seal, straight shaft, without key
201	20×10 <sup>1</sup> = 200W	C	Without oil seal, straight shaft, with key, tapped
401	40×10 <sup>1</sup> = 400W	E	With oil seal, straight shaft, with key
751	75×10 <sup>1</sup> = 750W	F	With oil seal, straight shaft, without key
851	85×10 <sup>1</sup> = 850W	G	With oil seal, straight shaft, with key, tapped
102	10×10 <sup>2</sup> = 1.0kW	Code	[Encoder]
132	13×10 <sup>2</sup> = 1.3kW	H	ABS/INC(18bit)*
152	15×10 <sup>2</sup> = 1.5kW	R	INC(20bit)
202	20×10 <sup>2</sup> = 2.0kW	T	INC(17bit)
302	30×10 <sup>2</sup> = 3.0kW		
402	40×10 <sup>2</sup> = 4.0kW		
502	50×10 <sup>2</sup> = 5.0kW		
552	55×10 <sup>2</sup> = 5.5kW		
702	70×10 <sup>2</sup> = 7.0kW		
Code	[Rated Speed]		
D	3000r/min series		
C	2000r/min series		
B	1500r/min series		
Code	[Development Order]		
5	5		
6	6		

\* Battery is necessary for ABS type.  
Note: Please see the model list on page 16, 17 for the combination detail.

Common specifications

Applicable motor rated speed	3000r/min										2000r/min										1500r/min					
	0.05	0.1	0.2	0.4	0.75	1.0	1.5	2.0	3.0	4.0	5.0	0.5	0.75	1.0	1.5	2.0	3.0	4.0	5.5	7.0	0.5	0.85	1.3			
Applicable motor output [kW]	201	401	751	152	202	302	402	502	751	152	202	302	402	502	751	152	202	302	402	751	152	202				
Amplifier type	RYH000FS-VV2																									
Outer frame number	1a	1b	2a	2b	3a	3b	4a	4b	2a	2b	3a	3b	4a	4b	2a	2b	3a	3b	4a	4b	2a	2b	3a			
Mass [kg]	0.8	1.2	1.3	2.2	2.2	3.6	1.2	1.3	2.2	3.6	1.2	1.3	2.2	3.6	1.2	1.3	2.2	3.6	1.2	1.3	2.2	3.6				
Protective construction / cooling	Open / natural cooling										Open / mechanical cooling										High-phase 3-phase	3-phase				
Power supply	Phase		Single-phase, 3-phase										3-phase										Single-phase, 3-phase			3-phase
	Voltage / frequency		200 to 240VAC 50/60Hz																							
	Allowable voltage fluctuation		3-phase : 170 to 264 VAC, Single-phase : 180 to 264 VAC																							
Control system	Fully-digital sinusoidal PWM drive																									
Max voltage for regenerative resistance [V]	Built-in resistor		-										20										30			
	External resistor		17										50										260			
Feedback	INC 20bit/rev, ABS/INC 18bit/rev																									
Overload capability	300% / 3 sec.																									
Speed fluctuation ratio*	Within ± 0.01% (load fluctuation 0 to 100% at rated operation speed)																									
	Power supply fluctuation 0% (power supply fluctuation -10 to +10% at rated operation speed)																									
	Temperature fluctuation Within ± 0.2% (25 ± 10°C at rated operation speed)																									
Capability and function	Speed control Closed loop control with speed adjuster, acceleration/deceleration time setting, manual feed rate/max. rotation speed, speed command zero clamp, etc.																									
	Number of position data sets 15-point (position, speed, acceleration/deceleration time setting, timer, M code and various statuses)																									
VV type	Position control Closed loop control with position adjuster, electronic gear, output pulse setting, feed forward, homing, interrupt positioning, auto startup, etc.																									
	Torque control Closed loop control with current adjuster (proportional open loop control of current and torque), torque limit, speed limit at torque control, etc.																									
	Accessory functions Easy tuning, profile operation, sequence test mode, auto tuning, auto notch filter, vibration suppressing online learning, etc.																									
Protective function (Alarm display)	Over Current (oc1, oc2), Over Speed (oS), High Voltage (Hu), Encoder Trouble (Et1, Et2), Circuit Trouble (ct), Data Error (dE), Combination Error (cE), Resistor Tr Heat (rH), Encoder Communication Error (Ec), Cont (CONTRol signal) Error (ctE), Over Load (oL1, oL2), Power Low Voltage (LuP), Resistor Heat (rH1, rH2, rH3), Over Flow (oF), Amp Heat (AH), Encoder Heat (EH), Absolute Data Lost (dL1, dL2, dL3), Absolute Data Over Flow (AF), Initial Error (iE)																									
Operation and display section of main body (keypad)	4-digit alphanumeric display with 7-segment LED 4 operation switches (MODE, SET, UP and DOWN)																									
Working conditions	Installation place Indoors at altitude ≤ 1000m, free from dust, corrosive gases and direct sunlight																									
	Temperature / humidity In case of compliance with CE marking: pollution degree 2, over voltage category III																									
	Vibration / shock resistance Vibration resistance: 3mm: 2 to 9Hz or less, 9.8m/s²: 9 to 20Hz or less, 2m/s²: 20 to 55Hz or less, 1m/s²: 55 to 200Hz or less																									
	Shock resistance: 19.6m/s² (2G)																									
Standards	UL/cUL (UL508c), CE marking (low voltage directive EN61800-5-1), RoHS directive (Some of the models are in the process to be certified.)																									

\*This value represents the average value of the speed fluctuation that is generated from load fluctuation, power supply fluctuation, and temperature fluctuation as the percentage to the rated rotation speed.

Interface Specifications

Terminal name	Symbol	Specifications	Item	Specifications
Pulse input	CA, *CA	Differential input: max. input frequency ≤ 1.0MHz	Command interface	Positioning function
	CB, *CB	Open collector input: max. input frequency ≤ 200kHz (in case of signals at 90-degree phase difference, the above relationship is true for the four-fold frequency.)		RS-485 (Modbus-RTU), Di/Do
Pulse output	PP1	Pull-up power input at open collector input (24VDC ± 5%)	Position control	Pulse input
	FFA, *FFA	Differential output: max. output frequency ≤ 1MHz	Speed control	Analog voltage input
	FFB, *FFB	Two signals at 90-degree phase difference	Torque control	Analog voltage input
	FFZ, *FFZ	Differential output: 1 pulse/rev	Communication interface	Two RS-485 ports (for parameter editing and monitor), Fuji's original protocol Modbus-RTU
Analog monitor voltage output	FZ	Open collector output: 1 pulse/rev		9600/19200/38400/115200 bps, connection of max. 31 units
	M5	Reference potential (0V)		
Common for sequence I/O	MON1	0V to ± 10VDC		
	MON2	Resolution: 14bits / ± full scale		
Sequence input signal	M5	The output data depends on internal parameter.		
	COMIN	Reference potential (0V)		
Sequence output signal	COMOUT	Common for sequence input signal		
	CONT1 to CONT5	Common for sequence output signal		
Analog voltage input (for speed and torque control)	OUT1 to OUT3	12VDC-10% to 24VDC+10%		
	COMOUT	Current consumption 8mA (per contact; used at circuit voltage of 12 to 24VDC)		
	OUT1 to OUT3	Function of each signal depends on parameter setting		
	COMOUT	Compatible with both sink and source input methods		
	OUT1 to OUT3	30VDC / 50mA (max.)		
	COMOUT	Function of each signal depends on parameter setting		
	OUT1 to OUT3	Compatible with both sink and source output methods		
	COMOUT	Reference potential		
	VREF	Speed command voltage input		
	TREF	Input range: from -10 to +10V, input impedance 20kΩ. Resolution: 15 bits / ± full scale		
	M5	Torque command voltage input		
	M5	Input range: from -10 to +10V, input impedance 20kΩ. Resolution: 14 bits / ± full scale		

VV Connection Diagram

Sample: frame 1

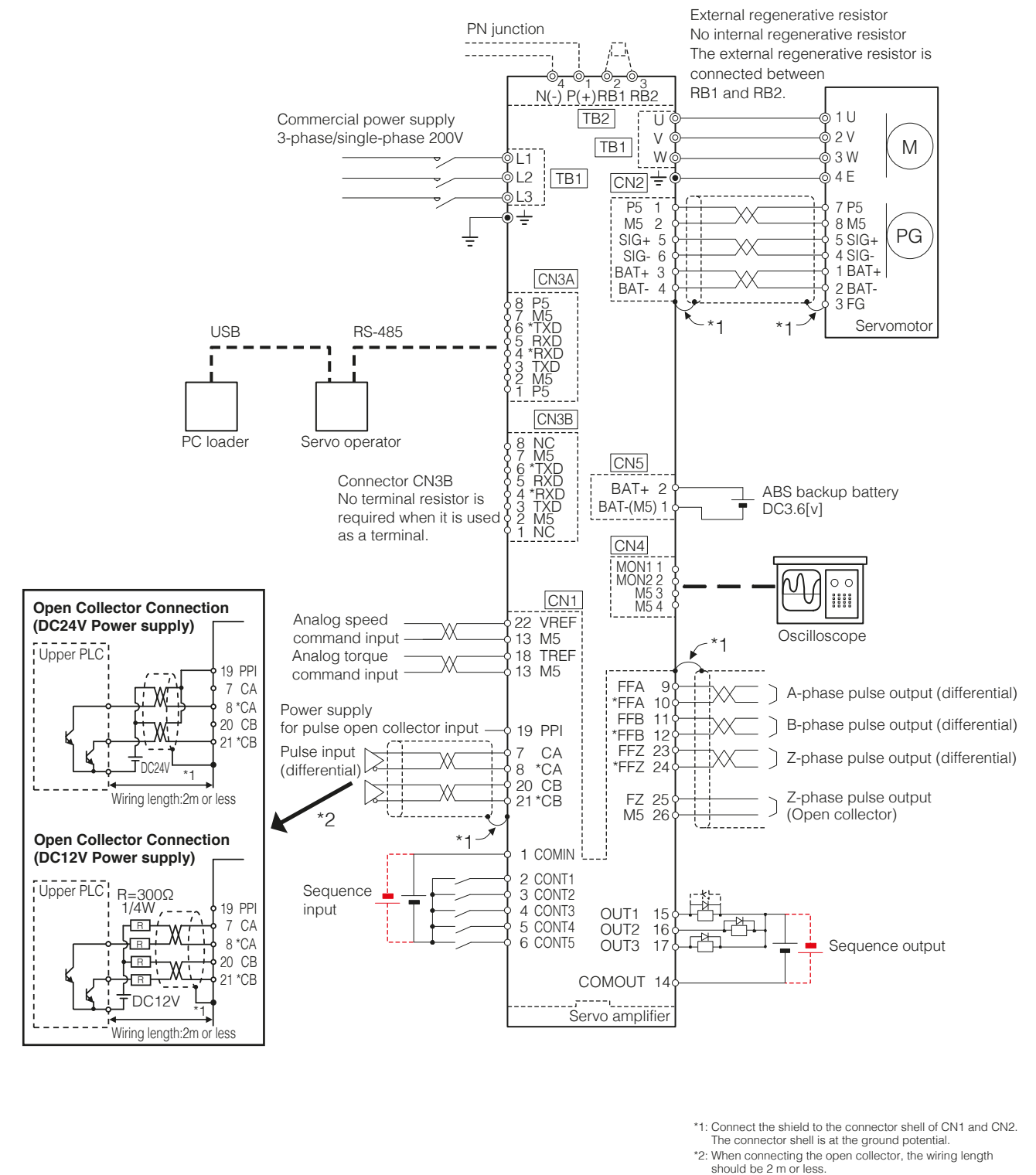

The diagram shown above is given as a reference for model selection. When actually using the selected servo system, make wiring connections according to the connection diagram and instructions described in the user's manual.

■ Middle Inertia GYB Motor [3000r/min]

■ Standard specifications

Motor type (-B) indicates the brake-incorporated type.	GYB201 D5-□□2 (-B)	GYB401 D5-□□2 (-B)	GYB751 D5-□□2 (-B)
Rated output [kW]	0.2	0.4	0.75
Rated torque [N · m]	0.637	1.27	2.39
Rated speed [r/min]	3000		
Max. speed [r/min]	6000 <sup>*1</sup>		
Max. torque [N · m]	1.91	3.82	7.17
Inertia [kg · m <sup>2</sup> ] ( ) indicates brake-incorporated type.	0.24 × 10 <sup>-4</sup> (0.29 × 10 <sup>-4</sup> )	0.42 × 10 <sup>-4</sup> (0.46 × 10 <sup>-4</sup> )	1.43 × 10 <sup>-4</sup> (1.61 × 10 <sup>-4</sup> )
Rated current [A]	1.5	2.7	5.2
Max. current [A]	4.5	8.1	15.6
Winding insulation class	Class B		
Degree of enclosure protection	Totally enclosed, self-cooled (IP 67, excluding the shaft-through) <sup>*2</sup>		
Terminals (motor)	0.3m cable		
Terminals (encoder)	0.3m cable		
Overheat protection	Not provided (The servo amplifier detects temperature.)		
Mounting method	By securing motor flange IMB5 (L51), IMV1 (L52), IMV3 (L53)		
Encoder	18-bit serial encoder (absolute/incremental), 20-bit serial encoder (incremental)		
Vibration level	V5 or below		
Installation place, altitude and environment	For indoor use (free from direct sunlight), 1000m or below, locations without corrosive and flammable gases, oil mist and dust		
Ambient temperature, humidity	-10 to +40°C, within 90% RH (without condensation)		
Vibration resistance [m/s <sup>2</sup> ]	49		
Mass [kg] ( ) indicates brake-incorporated type.	1.0 (1.5)	1.5 (2.1)	3.0 (3.9)
Compliance with standards	UL/cUL (UL508c) (Some models are in the process to be certified), CE marking (low power directive EN61800-5-1), RoHS directive.		

\*1: The max. speed of 5000r/min can be reached by using it with Fuji's gear head  
\*2: Protection degree IP67 is initial value

■ Brake specifications (motor equipped with a brake)

Motor type	GYB201 D5-□□2-B	GYB401 D5-□□2-B	GYB751 D5-□□2-B
Static friction torque [N · m]	1.27		2.45
Rated DC voltage [V]	DC24±10%		
Attraction time [ms]	40		60
Release time [ms]	20		25
Power consumption [W]	7.2 (at 20 °C)		8.5 (at 20 °C)

■ Torque characteristics diagrams (at 3-phase 200 [V] or single-phase 230 [V] source voltage)

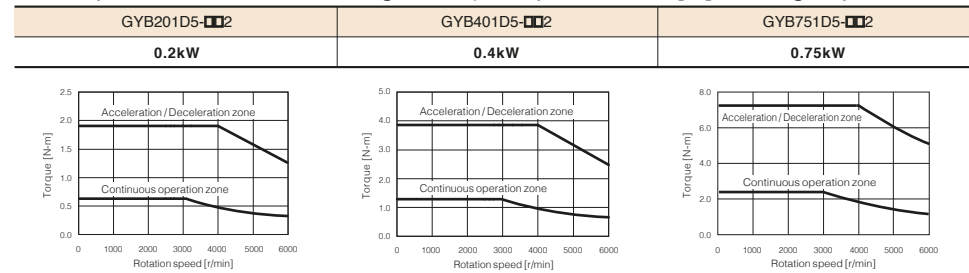

These characteristics indicate typical values of each servomotor combined with the corresponding servo amplifier RYH series.  
The rated torque indicates the value obtained when the servo amplifier is installed to the following aluminum heat sink.  
· Model GYB201, 401 : 250 × 250 × 6 [mm]  
· Model GYB751 : 300 × 300 × 6 [mm]

■ Middle Inertia GYH Motor [2000r/min]

■ Standard specifications

Motor type (-B) indicates the brake-incorporated type.	GYH102 C6-T□2 (-B)	GYH152 C6-T□2 (-B)	GYH202 C6-T□2 (-B)	GYH302 C6-T□2 (-B)	GYH402 C6-T□2 (-B)	GYH552 C6-T□2 (-B)	GYH702 C6-T□2 (-B)
Rated output [kW]	1.0	1.5	2.0	3.0	4.0	5.5	7.0
Rated torque [N · m]	4.77	7.16	9.55	14.32	19.10	26.26	33.42
Rated speed [r/min]	2000						
Max. speed [r/min]	2500						
Max. torque [N · m]	14.3	21.4	28.6	42.9	47.7	65.6	83.5
Inertia [kg · m <sup>2</sup> ] ( ) indicates brake-incorporated type.	6.26 × 10 <sup>-4</sup> (6.96 × 10 <sup>-4</sup> )	8.88 × 10 <sup>-4</sup> (9.58 × 10 <sup>-4</sup> )	12.14 × 10 <sup>-4</sup> (12.84 × 10 <sup>-4</sup> )	17.92 × 10 <sup>-4</sup> (18.62 × 10 <sup>-4</sup> )	39.99 × 10 <sup>-4</sup> (40.80 × 10 <sup>-4</sup> )	51.44 × 10 <sup>-4</sup> (52.31 × 10 <sup>-4</sup> )	63.52 × 10 <sup>-4</sup> (67.36 × 10 <sup>-4</sup> )
Rated current [A]	5.1	7.3	9	13.7	16	22.5	29
Max. current [A]	15.3	21.9	27	41.1	40.8	57.4	74.0
Winding insulation class	Class F						
Degree of enclosure protection	Totally enclosed, self-cooled (IP 67, excluding the shaft-through) <sup>*2</sup>						
Terminals (motor)	Cannon connector						
Terminals (encoder)	Cannon connector						
Overheat protection	Not provided (The servo amplifier detects temperature.)						
Mounting method	By securing motor flange IMB5 (L51), IMV1 (L52), IMV3 (L53)						
Encoder	17-bit serial encoder (incremental)						
Vibration level	V15 or below						
Installation place, altitude and environment	For indoor use (free from direct sunlight), 1000m or below, locations without corrosive and flammable gases, oil mist and dust						
Ambient temperature, humidity	0 to +40°C (there should be no freezing), within 90% RH (without condensation)						
Vibration resistance [m/s <sup>2</sup> ]	19.6						
Mass [kg] ( ) indicates brake-incorporated type.	6.5 (8.1)	8.1 (9.7)	10.2 (11.8)	13.9 (15.5)	19.5 (23.0)	26.2 (30.0)	30.0 (34.8)

\*1 The load inertia ratio to the inertia of servo motor. If the moment of load inertia ratio value exceeds the list value, please contact us.  
\*2 If the motor is used in the environment rated to IP67 protection degree, use the wiring connector suitable for the protection degree.

■ Brake specifications (motor equipped with a brake)

Motor type	GYH102 C6-T□2 (-B)	GYH152 C6-T□2 (-B)	GYH202 C6-T□2 (-B)	GYH302 C6-T□2 (-B)	GYH402 C6-T□2 (-B)	GYH552 C6-T□2 (-B)	GYH702 C6-T□2 (-B)
Static friction torque [N · m]	20				30		50
Rated DC voltage [V]	DC24±10%				DC24±5%		
Attraction time [ms]	100				110		150
Release time [ms]	27				25		40
Power consumption [W]	19.5 (at 20°C)				23 (at 20°C)		27 (at 20°C)

■ Torque characteristics diagrams (at 3-phase 200 [V] source voltage)

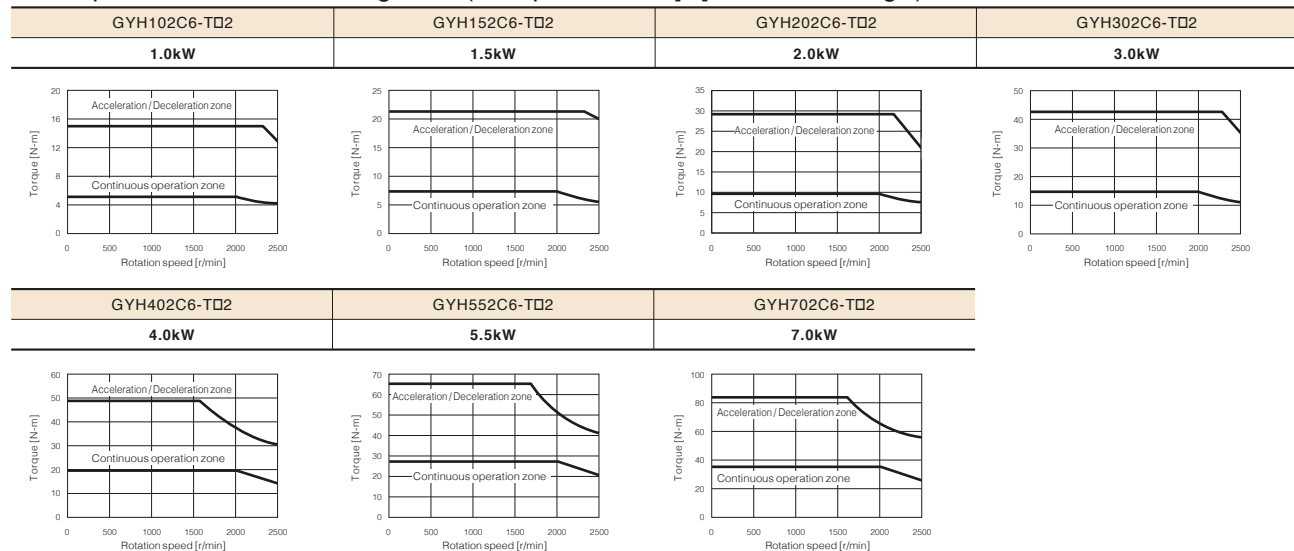

These characteristics indicate typical values of each servomotor combined with the corresponding servo amplifier RYH series.  
The rated torque indicates the value obtained when the servo amplifier is installed to the following aluminum heat sink.  
· Model GYH102,152,302 : 400 × 400 × 12 [mm]  
· Model GYH402,552,702 : 600 × 600 × 25 [mm]

■ Middle Inertia GYG Motor [2000r/min, 1500r/min]

■ Standard specifications

Motor type (-B) indicates the brake-incorporated type.	GYG501C5 -□□2 (-B)	GYG751C5 -□□2 (-B)	GYG102C5 -□□2 (-B)	GYG152C5 -□□2 (-B)	GYG202C5 -□□2 (-B)	GYG501B5 -□□2 (-B)	GYG851B5 -□□2 (-B)	GYG132B5 -□□2 (-B)
Rated output [kW]	0.5	0.75	1.0	1.5	2.0	0.5	0.85	1.3
Rated torque [N · m]	2.39	3.58	4.77	7.16	9.55	3.18	5.41	8.28
Rated speed [r/min]	2000							
Max. speed [r/min]	3000							
Max. torque [N · m]	7.2	10.7	14.3	21.5	28.6	9.5	16.2	24.8
Inertia [kg · m <sup>2</sup> ] ( ) indicates brake-incorporated type.	7.96 × 10 <sup>-4</sup> (10.0 × 10 <sup>-4</sup> )	11.55 × 10 <sup>-4</sup> (13.6 × 10 <sup>-4</sup> )	15.14 × 10 <sup>-4</sup> (17.2 × 10 <sup>-4</sup> )	22.33 × 10 <sup>-4</sup> (24.4 × 10 <sup>-4</sup> )	29.51 × 10 <sup>-4</sup> (31.6 × 10 <sup>-4</sup> )	11.55 × 10 <sup>-4</sup> (13.6 × 10 <sup>-4</sup> )	15.15 × 10 <sup>-4</sup> (17.3 × 10 <sup>-4</sup> )	22.33 × 10 <sup>-4</sup> (24.5 × 10 <sup>-4</sup> )
Rated current [A]	3.5	5.2	6.4	10.0	12.3	4.7	7.3	11.5
Max. current [A]	10.5	15.6	19.2	30.0	36.9	14.1	21.9	34.5
Winding insulation class	Class F							
Degree of enclosure protection	Totally enclosed, self-cooled (IP 67, excluding the shaft-through) <sup>*2</sup>							
Terminals (motor)	Cannon connector							
Terminals (encoder)	Cannon connector							
Overheat protection	Not provided (The servo amplifier detects temperature.)							
Mounting method	By securing motor flange IMB5 (L51), IMV1 (L52), IMV3 (L53)							
Encoder	18-bit serial encoder (absolute/incremental), 20-bit serial encoder (incremental)							
Vibration level	V10 or below							
Installation place, altitude and environment	For indoor use (free from direct sunlight), 1000m or below, locations without corrosive and flammable gases, oil mist and dust							
Ambient temperature, humidity	-10 to +40°C, within 90% RH (without condensation)							
Vibration resistance [m/s <sup>2</sup> ]	24.5							
Mass [kg] ( ) indicates brake-incorporated type.	5.3 (7.5)	6.4 (8.6)	7.5 (9.7)	9.8 (12.0)	12.0 (14.2)	6.4 (8.6)	7.5 (9.7)	9.8 (12.0)
Compliance with standards	UL/cUL (UL1004), CE marking (EN60034-1, EN60034-5), RoHS directive							

\*1 The load inertia ratio to the inertia of servo motor. If the moment of load inertia ratio value exceeds the list value, please contact us.  
\*2 If the motor is used in the environment rated to IP67 protection degree, use the wiring connector suitable for the protection degree.

■ Brake specifications (motor equipped with a brake)

Motor type	GYG501C5 -□□2-B	GYG751C5 -□□2-B	GYG102C5 -□□2-B	GYG152C5 -□□2-B	GYG202C5 -□□2-B	GYG501B5 -□□2-B	GYG851B5 -□□2-B	GYG132B5 -□□2-B
Static friction torque [N · m]	17							
Rated DC voltage [V]	DC24±10%							
Attraction time [ms]	120							
Release time [ms]	30							
Power consumption [W]	12 (at 20 °C)							

■ Torque characteristics diagrams (at 3-phase 200 [V] or single-phase 230 [V] source voltage)

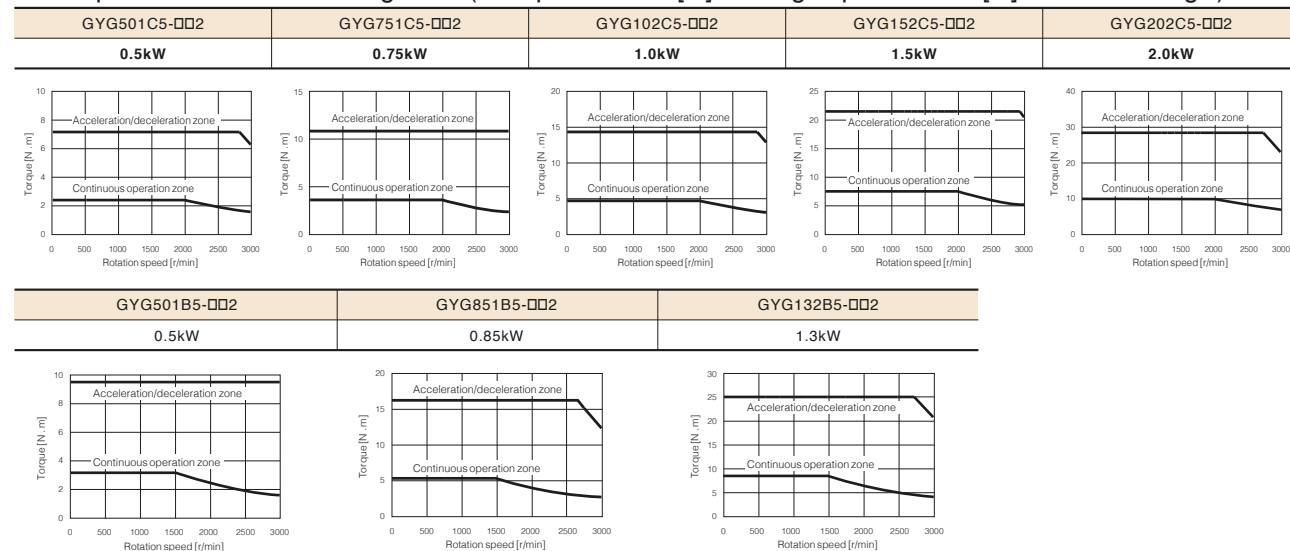

These characteristics indicate typical values of each servomotor combined with the corresponding servo amplifier RYH series.  
The rated torque indicates the value obtained when the servo amplifier is installed to the following aluminum heat sink.

- Model GYG501C, 751C, 102C : 300 × 300 × 12 [mm]
- Model GYG152C, 202C : 400 × 400 × 12 [mm]
- Model GYG501B, 851B : 300 × 300 × 12 [mm]
- Model GYG132B : 400 × 400 × 12 [mm]

■ Ultra-low Inertia GYS Motor [3000r/min]

■ Standard specifications

Motor type (-B) indicates the brake-incorporated type.	GYS500D5 -□□2 (-B)	GYS101D5 -□□2 (-B)	GYS201D5 -□□2 (-B)	GYS401D5 -□□2 (-B)	GYS751D5 -□□2 (-B)	GYS102D5 -□□2 (-B)	GYS152D5 -□□2 (-B)	GYS202D5 -□□2 (-B)	GYS302D5 -□□2 (-B)	GYS402D5 -□□2 (-B)	GYS502D5 -□□2 (-B)
Rated output [kW]	0.05	0.1	0.2	0.4	0.75	1.0	1.5	2.0	3.0	4.0	5.0
Rated torque [N · m]	0.159	0.318	0.637	1.27	2.39	3.18	4.78	6.37	9.55	12.7	15.9
Rated speed [r/min]	3000										
Max. speed [r/min]	6000 <sup>*1</sup>										
Max. torque [N · m]	0.478	0.955	1.91	3.82	7.17	9.55	14.3	19.1	28.7	38.2	47.8
Inertia [kg · m <sup>2</sup> ] ( ) indicates brake-incorporated type.	0.0192×10 <sup>-4</sup> (0.0223×10 <sup>-4</sup> )	0.0371×10 <sup>-4</sup> (0.0402×10 <sup>-4</sup> )	0.0742×10 <sup>-4</sup> (0.0804×10 <sup>-4</sup> )	0.1484×10 <sup>-4</sup> (0.1608×10 <sup>-4</sup> )	0.2968×10 <sup>-4</sup> (0.3216×10 <sup>-4</sup> )	0.478×10 <sup>-4</sup> (0.516×10 <sup>-4</sup> )	0.717×10 <sup>-4</sup> (0.774×10 <sup>-4</sup> )	1.026×10 <sup>-4</sup> (1.104×10 <sup>-4</sup> )	1.539×10 <sup>-4</sup> (1.652×10 <sup>-4</sup> )	2.052×10 <sup>-4</sup> (2.204×10 <sup>-4</sup> )	2.736×10 <sup>-4</sup> (2.94×10 <sup>-4</sup> )
Rated current [A]	0.85	0.85	1.5	2.7	4.8	7.1	9.6	12.6	18.0	24.0	30.0
Max. current [A]	2.55	2.55	4.5	8.1	14.4	21.3	28.8	37.8	54.0	72.0	90.0
Winding insulation class	Class B										
Degree of enclosure protection	Totally enclosed, self-cooled (IP 67, excluding the shaft-through and connectors)										
Terminals (motor)	Cable 0.3m (with connector)										
Terminals (encoder)	Cable 0.3m (with connector)										
Overheat protection	Not provided (The servo amplifier detects temperature.)										
Mounting method	By securing motor flange IMB5 (L51), IMV1 (L52), IMV3 (L53)										
Encoder	18-bit serial encoder (absolute/incremental), 20-bit serial encoder (incremental)										
Vibration level	V5 or below										
Installation place, altitude and environment	For indoor use (free from direct sunlight), 1000m or below, locations without corrosive and flammable gases, oil mist and dust										
Ambient temperature, humidity	-10 to +40°C, within 90% RH (without condensation)										
Vibration resistance [m/s <sup>2</sup> ]	49										
Mass [kg] ( ) indicates brake-incorporated type.	0.45 (0.62)	0.55 (0.72)	1.2 (1.7)	1.8 (2.3)	3.4 (4.2)	4.4 (5.9)	5.2 (6.8)	6.3 (7.9)	11.0 (13.0)	13.5 (15.5)	16.0 (18.0)
Compliance with standards	UL/cUL (UL1004), CE marking (EN60034-1, EN60034-5), RoHS directive										

\*1 The maximum rotation speed is 5000r/min when using the motor in combination with Fuji's gear head.  
\*2 If the motor is used in the environment rated to IP67 protection degree, use the wiring connector suitable for the protection degree.

■ Brake specifications (motor equipped with a brake)

Motor type	GYS500D5 -□□2-B	GYS101D5 -□□2-B	GYS201D5 -□□2-B	GYS401D5 -□□2-B	GYS751D5 -□□2-B	GYS102D5 -□□2-B	GYS152D5 -□□2-B	GYS202D5 -□□2-B	GYS302D5 -□□2-B	GYS402D5 -□□2-B	GYS502D5 -□□2-B
Static friction torque [N · m]	0.34										
Rated DC voltage [V]	DC24±10%										
Attraction time [ms]	35										
Release time [ms]	10										
Power consumption [W]	6.1 (at 20 °C)										

■ Torque characteristics diagrams (at 3-phase 200 [V] or single-phase 230 [V] source voltage)

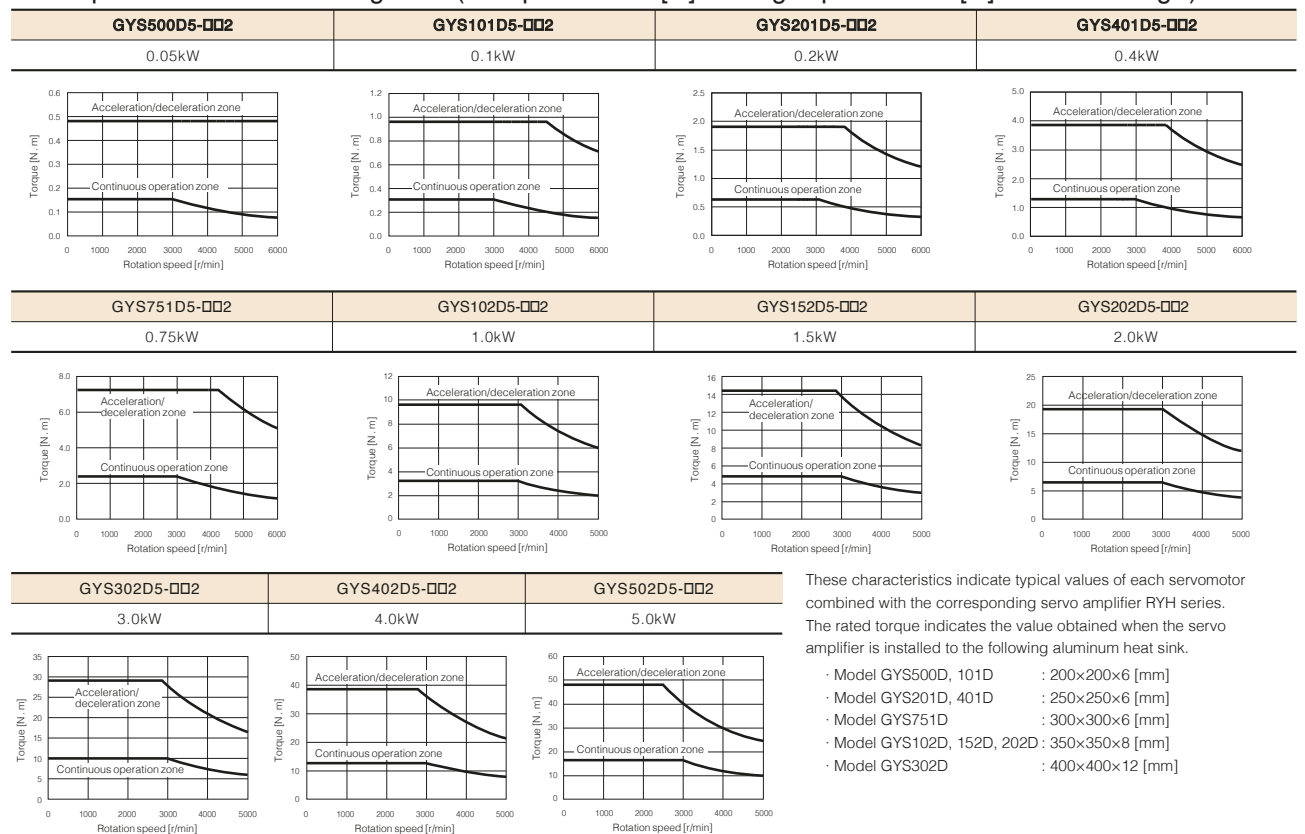

These characteristics indicate typical values of each servomotor combined with the corresponding servo amplifier RYH series.  
The rated torque indicates the value obtained when the servo amplifier is installed to the following aluminum heat sink.

- Model GYS500D, 101D : 200×200×6 [mm]
- Model GYS201D, 401D : 250×250×6 [mm]
- Model GYS751D : 300×300×6 [mm]
- Model GYS102D, 152D, 202D : 350×350×8 [mm]
- Model GYS302D : 400×400×12 [mm]

■ Sarvo amplifier

■ Frame 1

Applicable motor output	Type
200W, 100W, 50W	RYH201F5-VV2
400W	RYH401F5-VV2

(Unit : mm)

[Mass:0.8kg]

■ Frame 2

Applicable motor output	Type
500W, 750W, 1.0kW(GYH)	RYH751F5-VV2
850W, 1.0kW, 1.5kW, 2.0kW(GYH)	RYH152F5-VV2

(Unit : mm)

[Mass:1.3kg]

■ Frame 3

Applicable motor output	Type
1.3kW, 2.0kW, 3.0kW(GYH)	RYH202F5-VV2
3.0kW, 4.0kW(GYH)	RYH302F5-VV2

(Unit : mm)

[Mass:2.2kg]

■ Frame 4

Applicable motor output	Type
4.0kW, 5.5kW(GYH)	RYH402F5-VV2
5.0kW, 7.0kW(GYH)	RYH502F5-VV2

(Unit : mm)

[Mass:3.6kg]

■ Middle Inertia GYB Motor [3000r/min]

(Unit : mm)

Rated speed [r/min]	Rated output [kW]	Model codes (without brake)	L	LL	Flange dimensions							S	Mass [kg]
					LR	LG	LB	LC	LA	LD	LZ		
3000	0.2	GYB201D5-□B2	112	82	30	6	50	60	70	43	5.5	14	1.0
	0.4	GYB401D5-□B2	134	104	30	6	50	60	70	43	5.5	14	1.5
	0.75	GYB751D5-□B2	157	117	40	8	70	80	90	53	7	19	3.0

(Unit : mm)

Rated speed [r/min]	Rated output [kW]	Model codes (with brake)	L	LL	Flange dimensions							S	Mass [kg]
					LR	LG	LB	LC	LA	LD	LZ		
3000	0.2	GYB201D5-□B2-B	148	118	30	6	50	60	70	43	5.5	14	1.5
	0.4	GYB401D5-□B2-B	170	140	30	6	50	60	70	43	5.5	14	2.1
	0.75	GYB751D5-□B2-B	194.5	154.5	40	8	70	80	90	53	7	19	3.9

□ : Encoder type R : INC(20bit), H : ABS(18bit)



■ Middle Inertia GYH Motor [2000r/min]

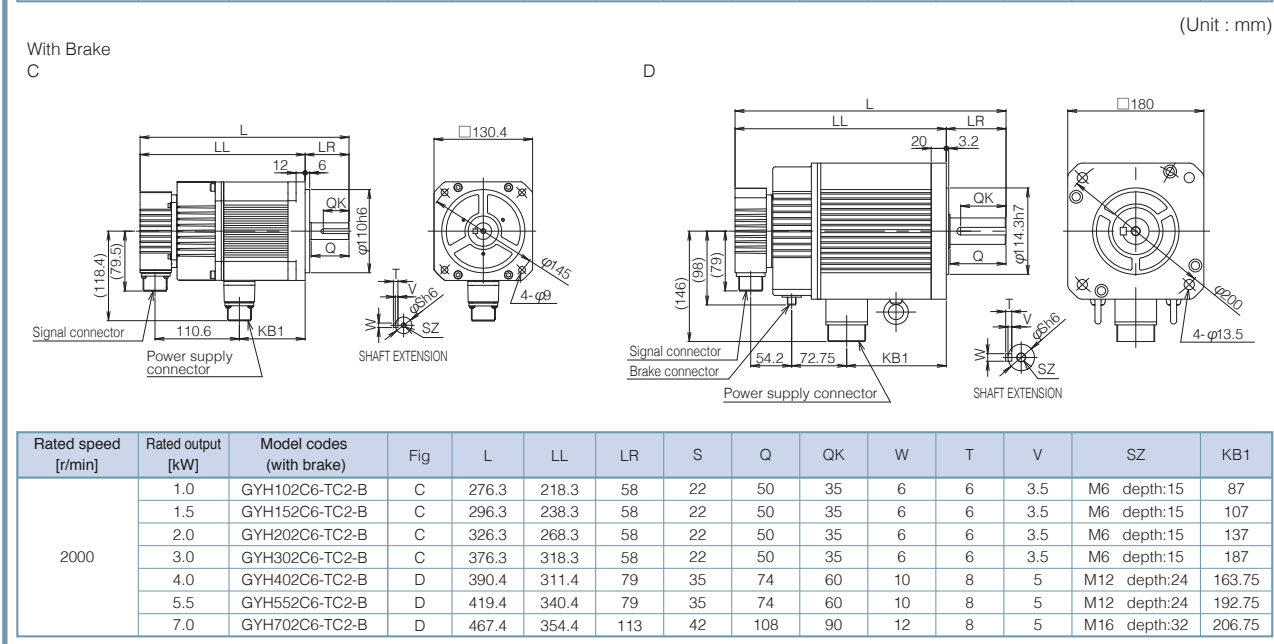
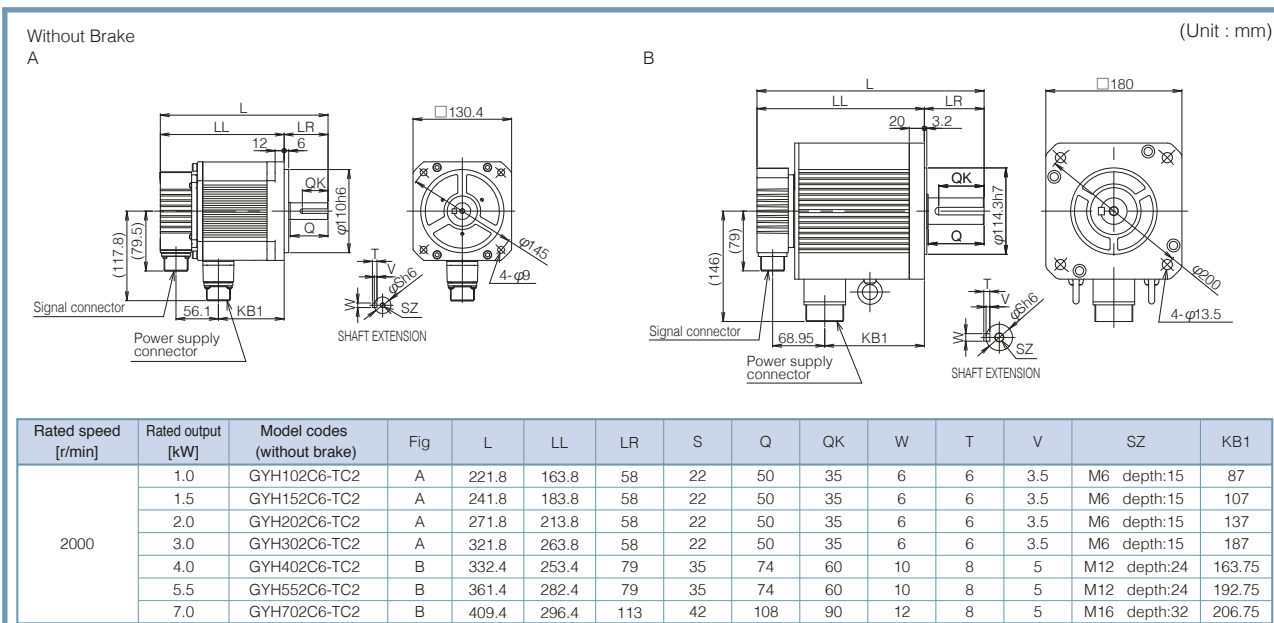

■ Middle Inertia GYG Motor [2000r/min, 1500r/min]

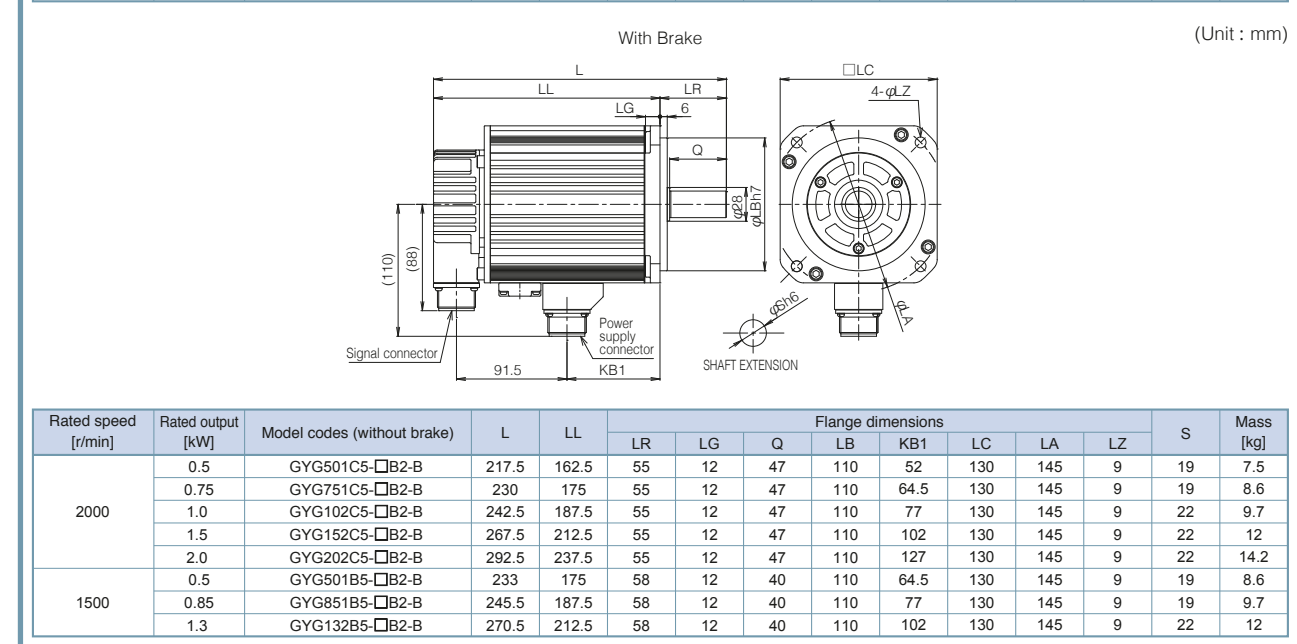
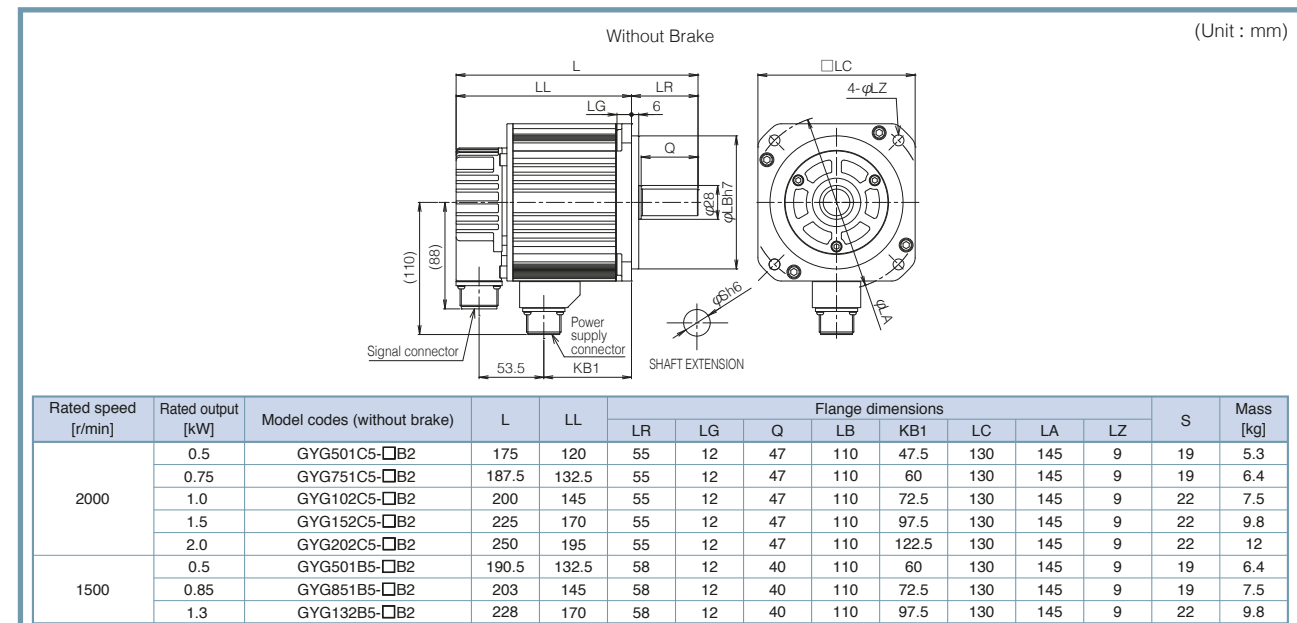

□ : Encoder type R : INC(20bit), H : ABS(18bit)

Ultra-low Inertia GYS Motor [3000r/min]

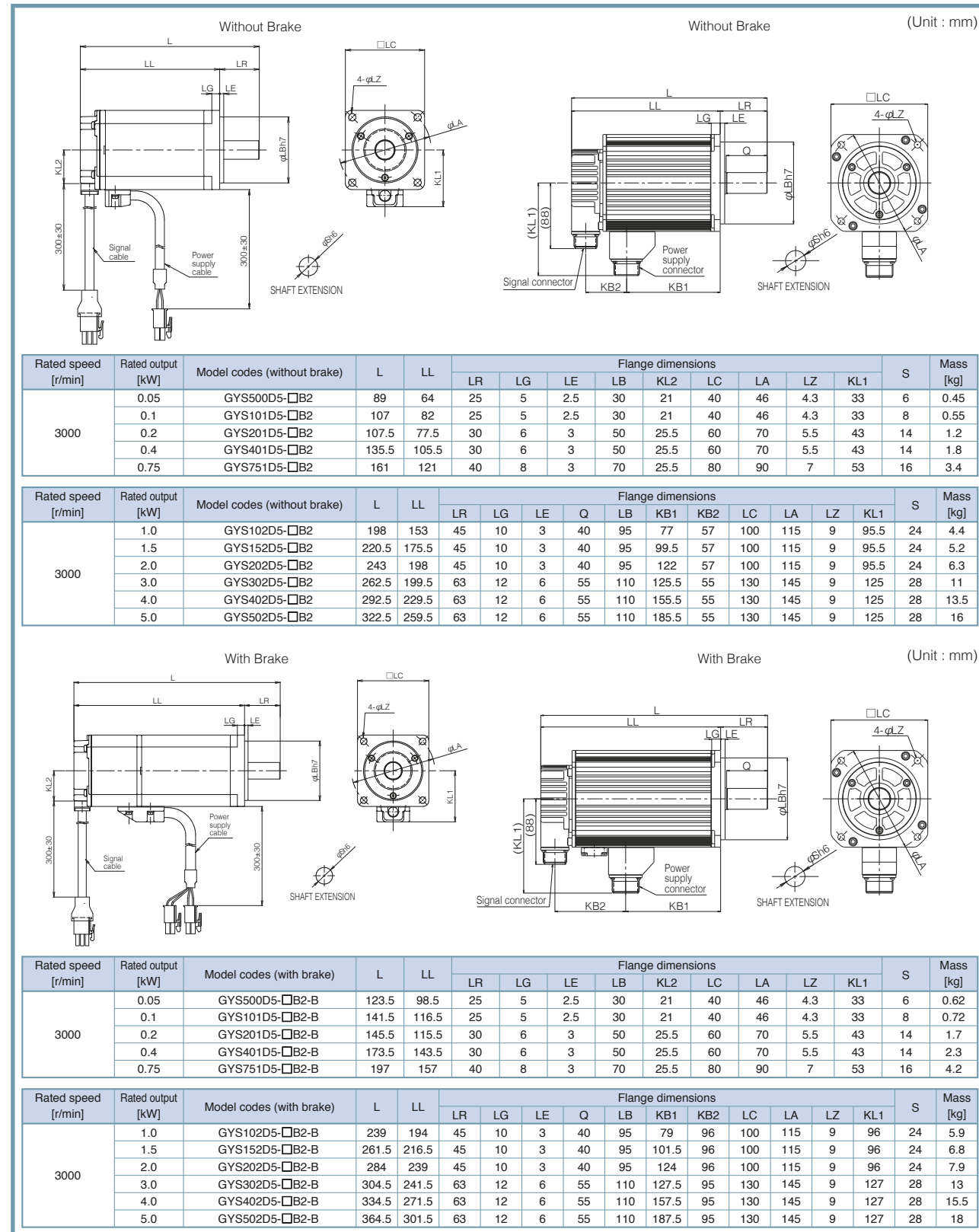

□ : Encoder type R : INC(20bit), H : ABS(18bit)

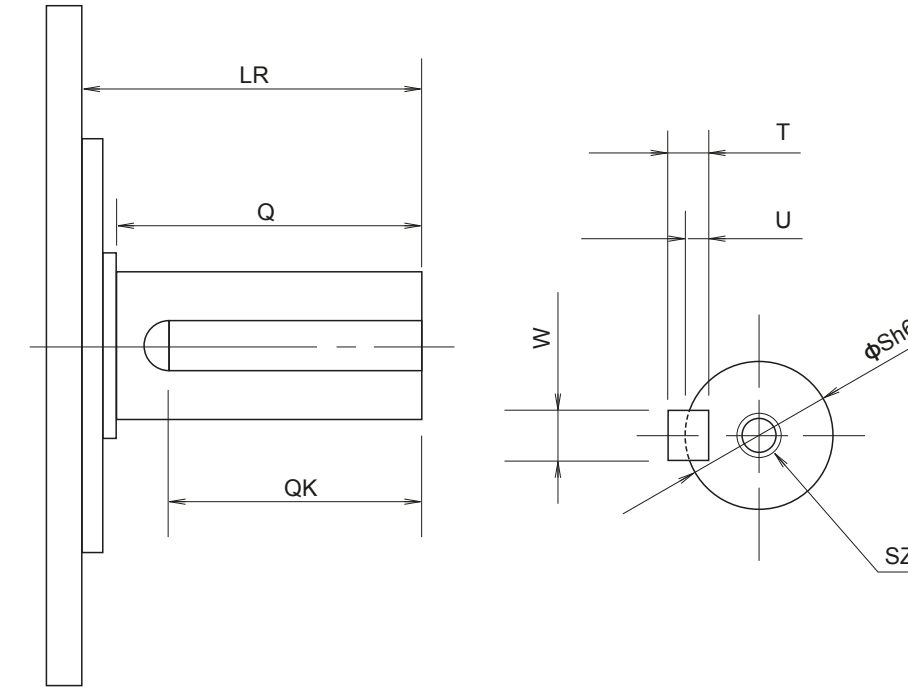

Motor type	LR	Q	QK	S	T	U	W	SZ		
<b>GYB motor</b>										
GYB201D5-□C2-□	30	-	14	14	5	3	5	M5 depth:8		
GYB401D5-□C2-□										
GYB751D5-□C2-□	40	-	22	19	6	3.5	6	M6 depth:10		
<b>GYG motor 2000r/min</b>										
GYG501C5-□C2-□	55	47	35	19	6	3.5	6	M6 depth:12		
GYG751C5-□C2-□				22	7	4	8	M8 depth:16		
GYG102C5-□C2-□										
GYG152C5-□C2-□										
GYG202C5-□C2-□										
<b>GYG motor 1500r/min</b>										
GYG501B5-□C2-□	58	40	30	19	6	3.5	6	M6 depth:12		
GYG851B5-□C2-□				22	7	4	8	M8 depth:16		
GYG132B5-□C2-□										
<b>GYS motor</b>										
GYS500D5-□A-□*1	25	-	14	6	2	1.2	2	-		
GYS101D5-□A-□*1				8	3	1.8	3	-		
GYS201D5-□C□-□	30	-	20	14	5	3	5	M5 depth:8		
GYS401D5-□C□-□										
GYS751D5-□C2-□				30	16					
GYS102D5-□C2-□	45	40	32	24	7	4	8	M8 depth:16		
GYS152D5-□C2-□										
GYS202D5-□C2-□										
GYS302D5-□C2-□				63	55	45	28			
GYS402D5-□C2-□										
GYS502D5-□C2-□										

\*1 The shaft extension of the GYS and GYC motors of 0.1kW or less is not tapped. The GYH type is a standard specification motor equipped with a key.

Configuration diagram

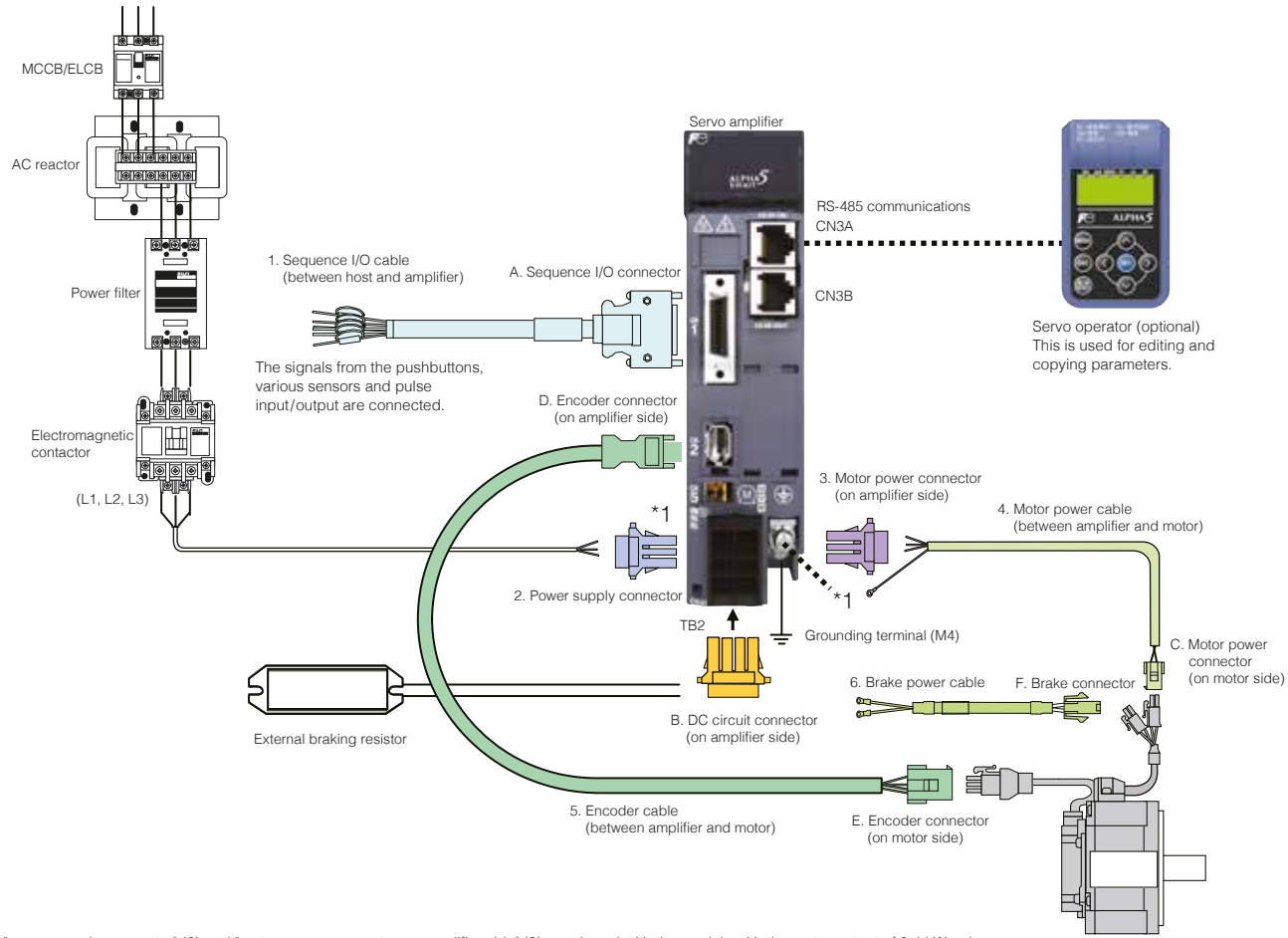

\*1: "power supply connector" (2) and "motor power connector on amplifier side" (3) are shared with the models with the motor output of 0.4 kW or less.

Peripheral equipment

Input power	Rated speed	Motor output [kW]	Applicable servo amplifier type	Power capacity [kVA]	Input current [A]	Power filter	AC reactor	Wiring breaker MCCB	Earth leakage breaker ELCB	Electromagnetic contactor MC			
Single-phase 200V	3000r/min	0.05		0.1	0.7	RNFTC06-20	ACR2-0.4A	BW32AAG-2P003	EW32AAG-2P003	SC-03			
		0.1	RH201F5-VV2	0.2	1.3		ACR2-0.75A	BW32AAG-2P005	EW32AAG-2P005				
		0.2		0.4	2.4								
		0.4	RH401F5-VV2	0.8	4.7		RNFTC10-20	ACR2-1.5A	BW32AAG-2P010		EW32AAG-2P010		
		0.75	RH751F5-VV2	1.5	8.6		RNFTC20-20	ACR2-2.2A	BW32AAG-2P015		EW32AAG-2P015		
		0.75		1.0	5.8								
	2000r/min	0.5	RH751F5-VV2	1.5	8.6	RNFTC20-20	ACR2-1.5A	BW32AAG-2P010	EW32AAG-2P010	SC-03			
		0.75		1.5	8.6					SC-0			
		1500r/min	0.5	RH751F5-VV2	1.0	5.8	RNFTC10-20	ACR2-1.5A	BW32AAG-2P010	EW32AAG-2P010	SC-03		
			3-phase 200V	3000r/min	0.05		0.1	0.4	RNFTC06-20	ACR2-0.4A	BW32AAG-3P003	EW32AAG-3P003	SC-03
					0.1	RH201F5-VV2	0.2	0.7					
					0.2		0.4	1.4					
0.4	RH401F5-VV2				0.8	2.7							
0.75	RH751F5-VV2				1.5	5.0	RNFTC10-20	ACR2-1.5A		BW32AAG-3P010	EW32AAG-3P010		
1.0		2.0			6.6								
2000r/min	0.5	RH751F5-VV2		1.5	8.6	RNFTC20-20	ACR2-2.2A	BW32AAG-3P015	EW32AAG-3P015	SC-4-1			
	0.75			1.5	8.6					SC-0			
	1.0	RH152F5-VV2		2.9	9.8								
	1.5			3.9	13.0	RNFTC20-20	ACR2-3.7A	BW32AAG-3P020	EW32AAG-3P020	SC-4-1			
	2.0	RH202F5-VV2		5.9	19.5	RNFTC30-20	ACR2-5.5A	BW50AAG-3P040	EW50AAG-3P040	SC-N1			
	3.0	RH302F5-VV2		7.8	26.5								
1500r/min	0.5	RH402F5-VV2	9.8	32.5	RNFTC50-20	ACR2-7.5A	BW50AAG-3P050	EW50AAG-3P050	SC-N2				
	0.75		1.0	3.3	RNFTC06-20	ACR2-0.75A							
	1.0	RH751F5-VV2	1.5	5.0									
	1.5		2.0	6.6	RNFTC10-20	ACR2-1.5A	BW32AAG-3P010	EW32AAG-3P010	SC-03				
	2.0	RH152F5-VV2	2.9	9.8									
	2.0	RH202F5-VV2	3.9	13.0	RNFTC20-20	ACR2-2.2A	BW32AAG-3P015	EW32AAG-3P015	SC-4-1				
1500r/min	0.5	RH751F5-VV2	1.0	3.3	RNFTC06-20	ACR2-0.75A							
	0.85		1.7	5.6	RNFTC10-20	ACR2-1.5A	BW32AAG-3P010	BW32AAG-3P010	SC-03				
	1.3	RH202F5-VV2	2.6	8.5	RNFTC20-20	ACR2-2.2A	BW32AAG-3P015	EW32AAG-3P015	SC-0				

Options

Basic option \* Prepare the optional items below when using the ALPHA5 Smart series.

Motor series	Rated speed	Rated output	Brake	1. Sequence I/O cable (between host and amplifier)	2. Power supply connector	B. DC circuit connector (on amplifier side)	3. Motor power connector (on amplifier side)	4. Motor power cable (between amplifier and motor)	5. Encoder cable (between amplifier and motor)	6. Brake power cable
GYB motor	3000r/min	0.2kW, 0.4kW	W/o	WSC-D26P02 *4 WSC-D26P02-F *3 WSC-D26P03	WSK-S06P-F	WSK-R04P-F	*1			
		0.75kW	W/o							
		W/								
		W/	WSK-S03P-G		*2	WSK-M03P-G			WSC-M02P02-E (2m) WSC-M02P05-E (5m) WSC-M02P10-E (10m) WSC-M02P20-E (20m)	
GYH motor	2000r/min	1.0kW to 4.0W	W/o							
		5.5kW to 7.0kW	W/o							
		0.5kW to 2.0W	W/							
GYG motor	2000r/min	0.5kW to 2.0W	W/o					Prepared by customer		
GYG motor	1500r/min	0.5kW to 1.3kW	W/							
GYG motor	3000r/min	0.05kW to 0.4kW	W/o							
		0.75kW	W/o							
		1.0kW to 3.0kW	W/							
		4.0kW to 5.0kW	W/o							
			W/							

\*1: The connector is shared by the motor power (on the amplifier side) and the power supply.  
\*2: The connector is not necessary as it is included in the package of servo amplifier.  
\*3: When connecting the open collector, Please use the sequence input/output cable for open collector (DC24V).  
\*4: When connecting the open collector, Please use the sequence input/output cable for open collector (Outside DC24V).

## Options

## Connector kit options

\* If the cables are fabricated by the customer, please use the connectors below.

Motor series	Rated speed	Rated output	Brake	A. Sequence I/O connector	2. Power supply connector	B. DC circuit connector (on amplifier side)	3. Motor power connector (on amplifier side)	C. Motor power connector (on motor side)	Encoder connector		F. Brake connector	
									D. on amplifier side	E. on motor side		
GYB motor	3000r/min	0.2kW	W/o	WSK-D26P	WSK-S06P-F	WSK-R04P-F	*1	WSK-M04P-E	WSK-P09P-D	WSK-M02P-E	-	
		0.4kW	W/								-	
		0.75kW	W/o								-	
1.0kW	W/	-										
5.5kW	W/o	-										
to 7.0kW	W/	-										
GYH motor	2000r/min	1.0kW	W/o		WSK-S03P-G	*2	WSK-M03P-G	See table below.	See table below.	See table below.	See table below.	-
		to 4.0kW	W/									-
		5.5kW	W/o									-
GYG motor	2000r/min	0.5kW	W/o		WSK-S03P-G	*2	WSK-M03P-G	WSK-M04P-CA	WSK-M06P-CA	WSK-M04P-CA	WSK-M06P-CA	-
		to 2.0kW	W/									-
GYG motor	1500r/min	0.5kW	W/o		WSK-S03P-G	*2	WSK-M03P-G	WSK-M04P-CA	WSK-M06P-CA	WSK-M04P-CA	WSK-M06P-CA	-
		to 1.3kW	W/	-								
GYS motor	3000r/min	0.05kW	W/o	WSK-S06P-F	WSK-R04P-F	*1	WSK-M04P-E	WSK-P09P-D	WSK-M02P-E	WSK-M02P-E	-	
		to 0.4kW	W/								-	
		0.75kW	W/o								-	
		1.0kW	W/o								-	
		to 3.0kW	W/								-	
		4.0kW	W/o								-	
to 5.0kW	W/	-										

\*1: The connector is shared by the motor power (on the amplifier side) and the power supply.

\*2: The connector is not necessary as it is included in the package of servo amplifier.

\*3: When connecting the open collector, Please use the sequence input/output cable for open collector (DC24V).

\*4: When connecting the open collector, Please use the sequence input/output cable for open collector (Outside DC24V).

## Recommended connectors for GYH motor

Motor series	Rated speed	Rated output	Brake	Selectable connector installed on motor (for reference)	Motor power connector		F. Brake connector		Encoder connector (on motor side)	
					Connector	Cable clamp	Connector	Cable clamp	Connector	Cable clamp
GYH motor	2000r/min	1.0kW	W/o	MS3102A20-4P	MS3108B20-4S	MS3057-12A	-	-	MS3108B20-16S	MS3057-12A
		to 3.0kW	W/	MS3102A20-15P	MS3108B20-15S *1	-	-			
		4.0kW	W/o	MS3102A32-17P	MS3108B32-17S	MS3057-20A	-	-		
		to 7.0kW	W/	Power MS3102A32-17P Brake power supply MS3102A10SL-3P	MS3108B10SL-3S	MS3057-4A	-	-		

\*1: The GYH type is a standard specification motor equipped with a key.

## External regenerative resistor options

Amplifier frame	Built-in	External braking resistor type	External braking resistor type
RYH201F5-VV2	-	WSR-401	39 to 180
RYH401F5-VV2	-		39 to 90
RYH751F5-VV2	20W / 40 Ω	WSR-152	13 to 47
RYH152F5-VV2	20W / 15 Ω		8.2 to 27
RYH202F5-VV2	45W / 12 Ω	DB11-2	8.2 to 20
RYH302F5-VV2	45W / 12 Ω		8.2 to 13
RYH402F5-VV2	60W / 16 Ω	DB22-2	300W / 5.8 Ω
RYH502F5-VV3			

## ABS backup battery

Amplifier	Optional battery type	
	W/ battery case	Individual battery
All	WSB-SC	WSB-S

## Other option

Specifications	Type
For PC loader connection RS-232C - RS-485 conversion adaptor Cable	For connection of RS-485 port of VV type servo amplifier *1 2m (connector at both ends)
Servo operator *1	-
	NW0H-CNV
	WSC-PCL
	WSP-51

\*1: Use a commercially-available USB cable (USB-A : USB-B, or USB-A : mini-B) when connecting the servo operator to PC.

Use a commercially-available LAN cable when connecting the servo operation to the servo amplifier.

## Options

## WSZ controller

Product	Type Code	Main Specifications
Basic Main Units (Up to 100kHz)	WSZ-14MAR2-D24	8 points digital input; 6 points relay output; 1 RS232 port; 24VDC power supply
	WSZ-24MAR2-D24	14 points digital input; 10 points relay output; 1 RS232 port; 24VDC power supply
	WSZ-32MAR2-D24	20 points digital input; 12 points relay output; 1 RS232 port; 24VDC power supply
	WSZ-60MAR2-D24	36 points digital input; 24 points relay output; 1 RS232 port; 24VDC power supply
	WSZ-24MAT2-D24	14 points digital input; 10 points transistor output; 1 RS232 port; 24VDC power supply
Advanced Main Units (Up to 200kHz)	WSZ-14MCT2-D24	8 points digital input; 6 points transistor output; 1 RS232 port; 24VDC power supply
	WSZ-24MCT2-D24	14 points digital input; 10 points transistor output; 1 RS232 port; 24VDC power supply
	WSZ-32MCT2-D24	20 points digital input; 12 points transistor output; 1 RS232 port; 24VDC power supply
	WSZ-40MCT2-D24	24 points digital input; 16 points transistor output; 1 RS232 port; 24VDC power supply
	WSZ-60MCT2-D24	36 points digital input; 24 points transistor output; 1 RS232 port; 24VDC power supply
	WSZ-24MCT2-AC	14 points digital input; 10 points transistor output; 1 RS232 port; 100-240VAC power supply
	WSZ-40MCT2-AC	20 points digital input; 12 points transistor output; 1 RS232 port; 100-240VAC power supply
DIO Expansion Unit/Modules	WSZ-60MCT2-AC	24 points digital input; 16 points transistor output; 1 RS232 port; 100-240VAC power supply
	WSZ-24XYT-AC	36 points digital input; 24 points transistor output; 1 RS232 port; 100-240VAC power supply
	WSZ-24XYR-D24	14 points digital input; 10 points relay output; 24VDC power supply
	WSZ-8XYR	4 points digital input; 4 points relay output module
	WSZ-8XYT	4 points digital input; 4 points transistor output module
	WSZ-8YT	8 points transistor output module
	WSZ-8X	8 points 24VDC digital input
	WSZ-16YR	16 points relay output module
	WSZ-16YT	16 points transistor output module
	AIO Modules/Board	WSZ-2DA
WSZ-2TC		2ch. thermocouple temperature input module with 0.1°C resolution
WSZ-4A2D		4ch. analog input + 2ch analog output module
WSZ-6AD		6ch. analog input module
WSZ-6RTD		6ch. RTD temperature input module with 0.1°C resolution
WSZ-B2A1D		2ch. analog input + 1ch. analog output board
WSZ-6TC		6ch. thermocouple temperature input module
Temperature Measurement Modules	WSZ-16TC	16ch. thermocouple temperature input module
	WSZ-2A4TC	2ch. analog input + 4ch. thermocouple module
AI + Temperature Measurement Combo Module	WSZ-2A4TC	2ch. analog input + 4ch. thermocouple module
Load Cell Module	WSZ-1LC	1ch. load cell measurement module
Precision Load CellModule	WSZ-1HLC	1ch. High precision weighing control module with 24-bit resolution
Communication Modules/Boards	WSZ-CM22	2 ports RS232 communication module
	WSZ-CM55E	1 port RS485(Port3) + 1 port RS485(Port4) + Ethernet network interface communication module
	WSZ-CM55	2 ports RS485 communication module
	WSZ-CM25E	1 port RS232 + 1 port RS485 + Ethernet interface communication module
	WSZ-CB25	1 port RS232 + 1 port RS485 communication board
	WSZ-CBE	1 port 10 Base T Ethernet communication board
AIO Boards	WSZ-CBCAN	1 port CANopen communication board
	WSZ-B2DA	2ch. 12-bit analog output board (0 to 10V or 0 to 20mA)
Memory Pack	WSZ-PACK	Program memory pack
Communication Cables	WSZ-U2C-MD-180	Communication converter cable, main unit Port 0 RS232 to USB-A, 180cm
	WSZ-232P0-9F-150	Communication cable, main unit Port 0 RS232 to DB9F, 150cm
	WSZ-232P0-9M-400	Communication cable, main unit Port 0 RS232 to DB9M, 400cm

⋮ Servo Amplifier

Specifications							
Model	Control mode	Command interface	Input voltage	Applicable motor	Applicable motor output	Type	Stock Type
VV type	Position, speed and torque control (With built-in linear positioning function)	General-purpose interface (pulse or analog voltage) (Modbus-RTU)	Single or 3-phase 200 to 240V	GYB, GYH, GYS motor	0.2kW, 0.1kW, 0.05kW	RYPH201F5-VV2	⊙
					0.4kW	RYPH401F5-VV2	⊙
					0.75kW, 0.5kW, 1.0kW(GYH)	RYPH751F5-VV2	⊙
					1.5kW, 1.0kW, 0.85kW, 2.0kW(GYH)	RYPH152F5-VV2	⊙
					2.0kW, 1.3kW, 3.0kW(GYH)	RYPH202D5-VV2	⊙
			3.0kW(GYS), 4.0kW(GYH)		RYPH302F5-VV2	⊙	
			4.0kW(GYS), 5.5kW(GYH)		RYPH402F5-VV2	△	
			5.0kW(GYS), 7.0kW(GYH)		RYPH502F5-VV2	△	
			3-phase 200 to 240V		0.2kW	RYPH201D5-VV2	⊙
					0.4kW	RYPH401D5-VV2	⊙
0.75kW	RYPH751D5-VV2	⊙					
1.5kW	RYPH152D5-VV2	⊙					
2.0kW	RYPH202D5-VV2	⊙					

⋮ Servo Motor

Specifications									
Model	Voltage	Rated speed	Oil seal/shaft	Encoder	Brake	Rated output	Type	Stock Type	
GYB motor (middle inertia)	200V	3000r/min	with oil seal / with key, tapped	20bit INC	W/o	0.2kW	GYB201D5-RG2	⊙	
						0.4kW	GYB401D5-RG2	⊙	
						0.75kW	GYB751D5-RG2	⊙	
						0.2kW	GYB201D5-RG2-B	⊙	
						0.4kW	GYB401D5-RG2-B	⊙	
						0.75kW	GYB751D5-RG2-B	⊙	
				18bit ABS	W/o	0.2kW	GYB201D5-HG2	△	
						0.4kW	GYB401D5-HG2	△	
						0.75kW	GYB751D5-HG2	△	
						0.2kW	GYB201D5-HG2-B	△	
						0.4kW	GYB401D5-HG2-B	△	
						0.75kW	GYB751D5-HG2-B	△	
			without oil seal / with key, tapped	20bit INC	W/o	0.2kW	GYB201D5-RC2	⊙	
						0.4kW	GYB401D5-RC2	⊙	
						0.75kW	GYB751D5-RC2	⊙	
						0.2kW	GYB201D5-RC2-B	⊙	
						0.4kW	GYB401D5-RC2-B	⊙	
						0.75kW	GYB751D5-RC2-B	⊙	
				18bit ABS	W/o	0.2kW	GYB201D5-HC2	△	
						0.4kW	GYB401D5-HC2	△	
						0.75kW	GYB751D5-HC2	△	
						0.2kW	GYB201D5-HC2-B	△	
						0.4kW	GYB401D5-HC2-B	△	
						0.75kW	GYB751D5-HC2-B	△	
GYH motor (middle inertia)	200V	2000r/min	without oil seal / with key, tapped	20bit INC	W/o	1.0kW	GYH102C6-TC2	△	
						1.5kW	GYH152C6-TC2	△	
						2.0kW	GYH202C6-TC2	△	
						3.0kW	GYH302C6-TC2	△	
						4.0kW	GYH402C6-TC2	△	
						5.5kW	GYH552C6-TC2	△	
						7.0kW	GYH702C6-TC2	△	
						W/	1.0kW	GYH102C6-TC2-B	△
							1.5kW	GYH152C6-TC2-B	△
				2.0kW	GYH202C6-TC2-B		△		
				3.0kW	GYH302C6-TC2-B		△		
				4.0kW	GYH402C6-TC2-B		△		
				5.5kW	GYH552C6-TC2-B		△		
				7.0kW	GYH702C6-TC2-B		△		

Note: Please contact our sales, if the models outside the above are needed.

⊙: Standard △: Order-made

⋮ Servo Motor

Specifications													
Model	Voltage	Rated speed	Oil seal/shaft	Encoder	Brake	Rated output	Type	Stock Type					
GYG motor (middle inertia)	200V	2000r/min	with oil seal / with key, tapped	20bit INC	W/o	0.5kW	GYG501C5-RG2	⊙					
						0.75kW	GYG751C5-RG2	⊙					
						1.0kW	GYG102C5-RG2	⊙					
						1.5kW	GYG152C5-RG2	⊙					
						2.0kW	GYG202C5-RG2	⊙					
						0.5kW	GYG501C5-RG2-B	⊙					
						0.75kW	GYG751C5-RG2-B	⊙					
						1.0kW	GYG102C5-RG2-B	⊙					
						1.5kW	GYG152C5-RG2-B	⊙					
						2.0kW	GYG202C5-RG2-B	⊙					
						18bit ABS	W/o	0.5kW	GYG501C5-HG2	△			
								0.75kW	GYG751C5-HG2	△			
			1.0kW	GYG102C5-HG2	△								
			1.5kW	GYG152C5-HG2	△								
			2.0kW	GYG202C5-HG2	△								
			0.5kW	GYG501C5-HG2-B	△								
			0.75kW	GYG751C5-HG2-B	△								
			1.0kW	GYG102C5-HG2-B	△								
			1.5kW	GYG152C5-HG2-B	△								
			2.0kW	GYG202C5-HG2-B	△								
			GYG motor (ultra-low inertia)	200V	3000r/min			without oil seal / with key, tapped (* GYS motor of 0.1kW or less is not tapped.)	20bit INC	W/o	0.05kW	GYS00D5-RA2*	⊙
											0.1kW	GYS101D5-RA2*	⊙
						0.2kW	GYS201D5-RC2				⊙		
						0.4kW	GYS401D5-RC2				⊙		
0.75kW	GYS751D5-RC2	⊙											
1.0kW	GYS102D5-RC2	⊙											
1.5kW	GYS152D5-RC2	⊙											
2.0kW	GYS202D5-RC2	⊙											
3.0kW	GYS302D5-RC2	⊙											
4.0kW	GYS402D5-RC2	⊙											
5.0kW	GYS502D5-RC2	⊙											
W/	0.05kW	GYS00D5-RA2-B*				⊙							
	0.1kW	GYS101D5-RA2-B*				⊙							
	0.2kW	GYS201D5-RC2-B				⊙							
	0.4kW	GYS401D5-RC2-B				⊙							
	0.75kW	GYS751D5-RC2-B				⊙							
	1.0kW	GYS102D5-RC2-B				⊙							
	1.5kW	GYS152D5-RC2-B				⊙							
	2.0kW	GYS202D5-RC2-B	⊙										
	3.0kW	GYS302D5-RC2-B	⊙										
18bit ABS	W/o	0.05kW	GYS00D5-HA2*	△									
		0.1kW	GYS101D5-HA2*	△									
		0.2kW	GYS201D5-HC2	△									
		0.4kW	GYS401D5-HC2	△									
		0.75kW	GYS751D5-HC2	△									
		1.0kW	GYS102D5-HC2	△									
		1.5kW	GYS152D5-HC2	△									
		2.0kW	GYS202D5-HC2	△									
		3.0kW	GYS302D5-HC2	△									
W/	W/o	0.05kW	GYS00D5-HA2-B*	△									
		0.1kW	GYS101D5-HA2-B*	△									
		0.2kW	GYS201D5-HC2-B	△									
		0.4kW	GYS401D5-HC2-B	△									
		0.75kW	GYS751D5-HC2-B	△									
		1.0kW	GYS102D5-HC2-B	△									
		1.5kW	GYS152D5-HC2-B	△									
		2.0kW	GYS202D5-HC2-B	△									
		3.0kW	GYS302D5-HC2-B	△									
	W/	0.05kW	GYS00D5-HA2-B*	△									
		0.1kW	GYS101D5-HA2-B*	△									
		0.2kW	GYS201D5-HC2-B	△									
		0.4kW	GYS401D5-HC2-B	△									
		0.75kW	GYS751D5-HC2-B	△									
		1.0kW	GYS102D5-HC2-B	△									
		1.5kW	GYS152D5-HC2-B	△									
		2.0kW	GYS202D5-HC2-B	△									
		3.0kW	GYS302D5-HC2-B	△									

Note: Please contact our sales, if the models outside the above are needed.

⊙: Standard △: Order-made

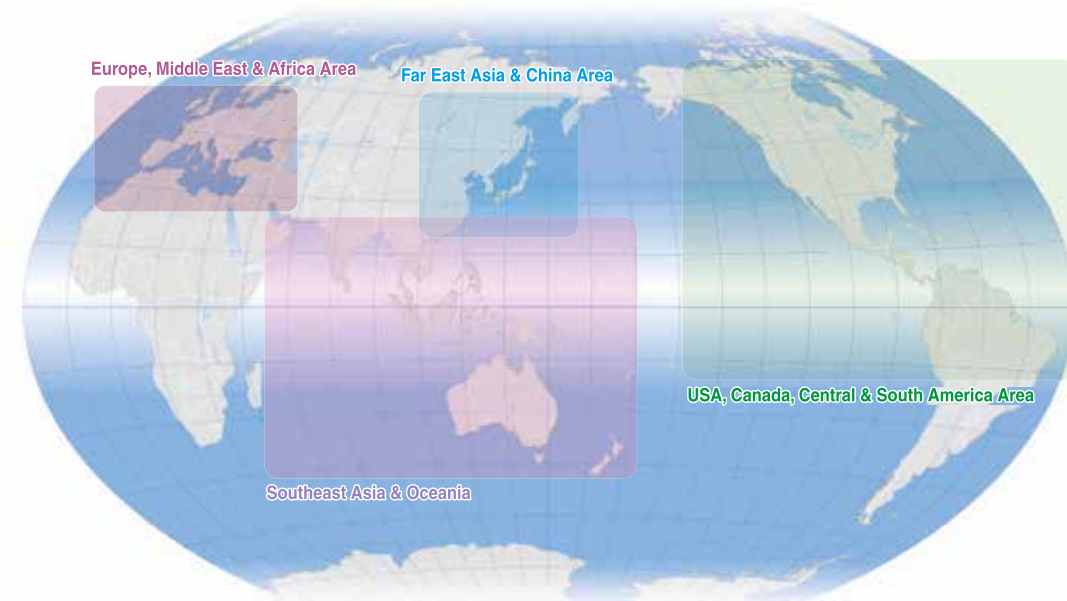

## Fuji FA Service Centers

## ● Far East Asia

Overseas Service Center  
Gate City Ohsaki, East Tower  
11-2,Osaki 1-Chome,Shinagawa-ku  
Tokyo,141-0032,Japan  
Tel: +81-3-5435-7059  
Fax: +81-3-5435-7447

## ■ Korea

• CANA ELECTRIC CO.,LTD.  
501 Ewha Bldg., 8-21, Yangjae-Dong,  
Seocho-Gu, Seoul, 137-887, Korea  
Tel:+82-2-3462-0670  
Fax:+82-2-3462-0678

## ■ Taiwan

• ELTA ELECTRICAL CO.,LTD.  
4F, No.32, Sec.3, Cheng-Teh Road, Taipei, Taiwan  
Tel:+886-2-2597-6458  
Fax:+886-2-2595-4571  
• FULL KEY SYSTEM CO., LTD.  
12F, No.111-8, Hsing-Teh Road, San-Chung City, Taipei, Taiwan  
Tel:+886-2-2995-2008  
Fax:+886-2-2995-2028

## ● Europe,Middle East &amp; Africa Area

EU Service Center  
Goethering 58,63067 Offenbach/Main Germany  
Tel: +49-69-66-90-29-0  
Fax: +49-69-66-90-29-58

## ● China Area

FUJI ELECTRIC (CHINA) CO.,LTD.  
Floor 29, International Corporate City,  
No 3000 North Zhongshan Road  
Shanghai China (P.C.200063)  
Tel: +86-21-5496-1177  
Fax: +86-21-6228-0350

## ● Southeast Asia &amp; Oceania

Southeast Asia & Oceania Service Center  
171 Chin Swee Road, #12-01 San Centre,  
Singapore 169877  
Tel: +65-6533-0014  
Fax: +65-6533-0021

## ● USA,Canada,Cental &amp; South America Area

USA Service Center  
47520 Westinghouse Drive  
Fremont,CA 94539,USA  
Tel: +1-510-440-1060  
Fax: +1-510-440-1063

Please access the URL below for further details:  
[http://www.fujielectric.co.jp/products/provide\\_data/drive/network/world/world-top.html](http://www.fujielectric.co.jp/products/provide_data/drive/network/world/world-top.html)

## Please take the following items into consideration when placing your order.

When requesting an estimate and placing your orders for the products included in these materials, please be aware that any items such as specifications which are not specifically mentioned in the contract, catalog, specifications or other materials will be as mentioned below. In addition, the products included in these materials are limited in the use they are put to and the place where they can be used, etc., and may require periodic inspection. Please confirm these points with your sales representative or directly with this company. Furthermore, regarding purchased products and delivered products, we request that you take adequate consideration of the necessity of rapid receiving inspections and of product management and maintenance even before receiving your products.

## 1. Free of Charge Warranty Period and Warranty Range

## 1-1 Free of charge warranty period

- (1) The product warranty period is "1 year from the date of purchase" or 24 months from the manufacturing date imprinted on the name place, whichever date is earlier.
- (2) However, in cases where the use environment, conditions of use, use frequency and times used, etc., have an effect on product life, this warranty period may not apply.
- (3) Furthermore, the warranty period for parts restored by Fuji Electric's Service Department is "6 months from the date that repairs are completed."

## 1-2 Warranty range

- (1) In the event that breakdown occurs during the product's warranty period which is the responsibility of Fuji Electric, Fuji Electric will replace or repair the part of the product that has broken down free of charge at the place where the product was purchased or where it was delivered. However, if the following cases are applicable, the terms of this warranty may not apply.
  - 1) The breakdown was caused by inappropriate conditions, environment, handling or use methods, etc. which are not specified in the catalog, operation manual, specifications or other relevant documents.
  - 2) The breakdown was caused by the product other than the purchased or delivered Fuji's product.
  - 3) The breakdown was caused by the product other than Fuji's product, such as the customer's equipment or software design, etc.
  - 4) Concerning the Fuji's programmable products, the breakdown was caused by a program other than a program supplied by this company, or the results from using such a program.
  - 5) The breakdown was caused by modifications or repairs affected by a party other than Fuji Electric.
  - 6) The breakdown was caused by improper maintenance or replacement using consumables, etc. specified in the operation manual or catalog, etc.
  - 7) The breakdown was caused by a chemical or technical problem that was not foreseen when making practical application of the product at the time it was purchased or delivered.
  - 8) The product was not used in the manner the product was originally intended to be used.
  - 9) The breakdown was caused by a reason which is not this company's responsibility, such as lightning or other disaster.
- (2) Furthermore, the warranty specified herein shall be limited to the purchased or delivered product alone.
- (3) The upper limit for the warranty range shall be as specified in item (1) above and any damages (damage to or loss of machinery or equipment, or lost profits from the same, etc.) consequent to or resulting from breakdown of the purchased or delivered product shall be excluded from coverage by this warranty.

## 1-3. Trouble diagnosis

As a rule, the customer is requested to carry out a preliminary trouble diagnosis. However, at the customer's request, this company or its service network can perform the trouble diagnosis on a chargeable basis. In this case, the customer is asked to assume the burden for charges levied in accordance with this company's fee schedule.

## 2. Exclusion of Liability for Loss of Opportunity, etc.

Regardless of whether a breakdown occurs during or after the free of charge warranty period, this company shall not be liable for any loss of opportunity, loss of profits, or damages arising from special circumstances, secondary damages, accident compensation to another company, or damages to products other than this company's products, whether foreseen or not by this company, which this company is not be responsible for causing.

## 3. Repair Period after Production Stop, Spare Parts Supply Period (Holding Period)

Concerning models (products) which have gone out of production, this company will perform repairs for a period of 7 years after production stop, counting from the month and year when the production stop occurs. In addition, we will continue to supply the spare parts required for repairs for a period of 7 years, counting from the month and year when the production stop occurs. However, if it is estimated that the life cycle of certain electronic and other parts is short and it will be difficult to procure or produce those parts, there may be cases where it is difficult to provide repairs or supply spare parts even within this 7-year period. For details, please confirm at our company's business office or our service office.

## 4. Transfer Rights

In the case of standard products which do not include settings or adjustments in an application program, the products shall be transported to and transferred to the customer and this company shall not be responsible for local adjustments or trial operation.

## 5. Service Contents

The cost of purchased and delivered products does not include the cost of dispatching engineers or service costs. Depending on the request, these can be discussed separately.

## 6. Applicable Scope of Service

Please inquiry the supplier or Fuji Electric China for details of above.