



Automation for a Changing World

Delta AC Servo Drive & Motor ASDA-A3 Series

Ordering Information

Product Line Up

Servo Motors							Servo Drives		
Motor Series	Phase	Rated Output Power (W)	Model Name	Rated current (Arms)	Max. current (Arms)	Model Name	Continuous Output Current (Arms)	Max. Instantaneous Current (Arms)	
Low Inertia	ECM-A3L 3000 r/min	1-phase / 3-phase	50	ECM-A3L-C ¹ 040F ² S1	0.66	2.82	ASD-A3-0121	0.9	3.54
			100	ECM-A3L-C ¹ 0401 ² S1	0.9	3.88			
			200	ECM-A3L-C ¹ 0602 ² S1	1.45	6.2	ASD-A3-0221	1.55	7.07
			400	ECM-A3L-C ¹ 0604 ² S1	2.65	10.1	ASD-A3-0421	2.6	10.61
			400	ECM-A3L-C ¹ 0804 ² 71	2.6	10.6			
			750	ECM-A3L-C ¹ 0807 ² S1	5.1	20.6	ASD-A3-0721	5.1	21.21
Medium-High Inertia	ECMC-C 3000 r/min	1-phase / 3-phase	1000	ECMC-CW1010 ² S	7.3	21.9	ASD-A3-1021	7.3	24.75
	ECMC-E 2000 r/min		1-phase / 3-phase	1000	ECMC-EW1310 ² S	5.6			
		1500		ECMC-EW1315 ² S	8.3	24.9	ASD-A3-2023	13.4	53.03
		2000		ECMC-EW1320 ² S	11.01	33.0			
		2000		ECMC-EW1820 ² S	11.22	33.7			
	3000	ECMC-EW1830 ² S	16.1	48.3	ASD-A3-3023	19.4	70.71		
ECMC-F 1500 r/min	3-phase	3000	ECMC-FW1830 ² S	19.4				58.2	
High Inertia	ECM-A3H 3000 r/min	1-phase / 3-phase	50	ECM-A3H-C ¹ 040F ² S1	0.64	2.59	ASD-A3-0121	0.9	3.54
			100	ECM-A3H-C ¹ 0401 ² S1	0.9	3.64			
			200	ECM-A3H-C ¹ 0602 ² S1	1.45	5.3	ASD-A3-0221	1.55	7.07
			400	ECM-A3H-C ¹ 0604 ² S1	2.65	9.8	ASD-A3-0421	2.6	10.61
			400	ECM-A3H-C ¹ 0804 ² 71	2.6	9.32			
			750	ECM-A3H-C ¹ 0807 ² S1	4.61	16.53	ASD-A3-0721	5.1	21.21
	ECMC-F 1500 r/min	1-phase / 3-phase	850	ECMC-FW1308 ² S	7.1	19.4	ASD-A3-1021	7.3	24.75
			1300	ECMC-FW1313 ² S	12.6	38.6	ASD-A3-2023	13.4	53.03
			1800	ECMC-FW1318 ² S	13	36	ASD-A3-2023	13.4	53.03

Note: In servo motor model names, ¹ signifies encoder type, ² signifies brake or keyway/oil seal.

Ordering Information

Model Name Explanation

ASDA-A3 Series Servo Drives

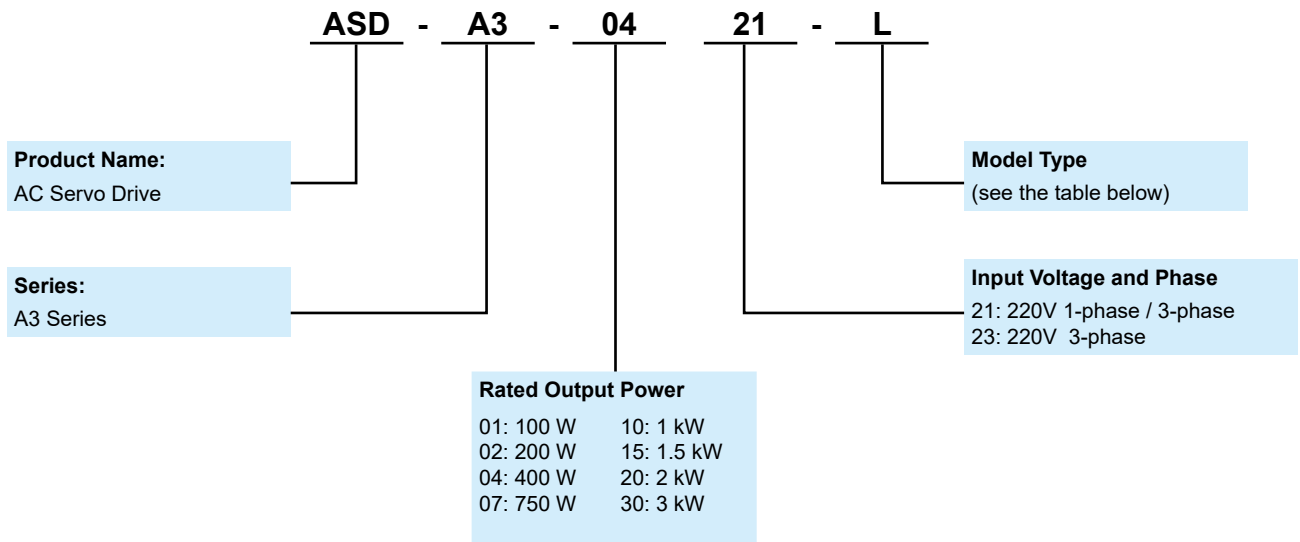



Type	PT Mode Pulse Train	PR Mode	RS-485	CANopen	DMCNET	EtherCAT	Full- closed Loop Control	Analog Voltage Control	E-CAM	STO
L	○	○	○	X	X	X	○	○	X	X
M	○	○	○	○	X	X	○	○	○	○
F	X	○	X	X	○	X	○	X	○	X
E*	X	○	X	X	X	○	○	X	○	○

Note: Models with a * mark are the ones to be launched.



Servo Drive Specifications

ASDA-A3		100 W	200 W	400 W	750 W	1 kW	1.5 kW	2 kW	3 kW	
		01	02	04	07	10	15	20	30	
Power supply	Phase / Voltage	Single-phase / three-phase 220 VAC						Three-phase 220 VAC		
	Permissible Voltage Range	Single-phase / three-phase 200~230 VAC, -15%~10%						Three-phase 200~230 VAC, -15%~10%		
	Input Current(3PH) (Units: Arms)	0.67	1.34	2.67	5.01	6.68	10.02	13.36	20.05	
	Input Current(1PH) (Units: Arms)	1.16	2.31	4.63	8.68	11.57	17.36	-	-	
	Continuous Output Current (Units: Arms)	0.9	1.55	2.65	5.1	7.3	12.6	13.4	19.4	
Instantaneous Maximum Output Current (Units: Arms)		3.54	7.07	10.61	21.21	24.75	35.36	53.03	70.71	
Cooling System		Natural Air Circulation			Fan Cooling					
Drive resolution		24-bit (16777216 p/rev)								
Control of Main Circuit		SVPWM Control								
Tuning Modes		Auto / Manual								
Regenerative Resistor		None			Built-in					
Position Control Mode	Pulse Type (Only for Non-DMCNET mode)		Pulse + Direction, A phase + B + CW pulse							
	Max. Input Pulse Frequency (Only for Non-DMCNET mode)		Pulse + Direction: 4Mpps ; CCW pulse + CW pulse: 4Mpps ; A phase + B phase: Single phase 4Mpps ; Max. 200Kpps (Open collector)p/s							
	Command Source		External pulse train (PT mode) (Only for Non-DMCNET mode) / Internal parameters (PR mode)							
	Smoothing Strategy		Low-pass and P-curve filter							
	Electronic Gear		Electronic gear N/M multiple N: 1~536870911, M: 1~2147483647 (1/4 < N/M < 262144)							
	Torque Limit Operation		Set by parameters							
	Feed Forward Compensation		Set by parameters							
Speed Control Mode	Analog Input Command (Only for Non-DMCNET mode)	Voltage Range	0 ~ ±10 V _{DC}							
		Resolution	15-bit							
	Input Resistance	1MΩ								
		Time Constant	25 μs							
	Speed Control Range ^{*1}		1 : 6000							
	Command Source		External analog signal (Only for Non-DMCNET mode) / Internal parameters							
	Smoothing Strategy		Low-pass and S-curve filter							
Torque Limit Operation		Set by parameters or analog input (Only for Non-DMCNET mode)								
Frequency Response Characteristic		Maximum 3.1kHz								
Speed Accuracy ^{*2}		0.01% or less at 0 to 100% load fluctuation								
		0.01% or less at ±10% power fluctuation								
		0.01% or less at 0°C to 50°C ambient temperature fluctuation								
Torque Control Mode	Analog Input Command (Only for Non-DMCNET mode)	Voltage Range	0 ~ ±10 V _{DC}							
		Input Resistance	1MΩ							
	Time Constant	25 μs								
		Command Source	External analog signal (Only for Non-DMCNET mode) / Internal parameters							
Smoothing Strategy		Low-pass filter								
Speed Limit		Set by parameters or analog input (Only for Non-DMCNET mode)								
Analog Monitor Output		Monitor signal can set by parameters (Output voltage range: ±8V)								
Digital Inputs / Outputs	Inputs	Servo on, Reset, Gain switching, Pulse clear, Zero speed CLAMP, Command input reverse control, Command triggered, Speed / Torque limit enabled, Position command selection, Motor stop, Speed position selection, Position / Speed mode switching, Speed / Torque mode switching, Torque / Position mode switching, PT / PR command switching, Emergency stop, Forward / Reverse inhibit limit, Reference "Home" sensor, Forward / Reverse operation torque limit, Move to "Home", Electronic Cam (E-Cam), Forward / Reverse JOG input, Event trigger PR command, Electronic gear ratio (Numerator) selection and Pulse inhibit input * Please note that the above digital signals and inputs are available only for Non-DMCNET mode. In DMCNET mode, it is recommended to write digital inputs into the servo drives through DMCNET communication, and the digital inputs should be used for Emergency Stop, Forward / Reverse Inhibit limit and Reference "Home" sensor only.								
	Outputs	Encoder signal output (A, B, Z Line Driver and Z Open Collector) Servo ready, Servo on, At Zero speed, At Speed reached, At Positioning completed, At Torques limit, Servo alarm (Servo fault) activated, Electromagnetic brake control, Homing completed, Output overload warning, Servo warning activated, Position command overflow, Forward / Reverse software limit, Internal position command completed, Capture operation completed output., Motion control completed output., Master position of E-Cam (Electronic Cam)								
Protective Functions		Overcurrent, Overvoltage, Undervoltage, Motor overheated, Regeneration error, Overload, Overspeed, Abnormal pulse control command, Excessive deviation, Encoder error, Adjustment error, Emergency stop activated, Reverse/ Forward limit switch error, Position excessive deviation of full-close control loop, Serial communication error, Input power phase loss, Serial communication time out, short circuit protection of U, V, W, and CN1, CN2, CN3 terminals								
Communication Interface		RS-485 / CANopen / USB								
Environment	Installation Site		Indoor environment (free of direct sunlight), no corrosive liquid and gas (free of oil mist, flammable gas, or dust)							
	Altitude		Altitude 2000m or lower above sea level							
	Atmospheric Pressure		86kPa ~ 106kPa							
	Operating Temperature		0°C ~ 55°C (If operating temperature is above 45°C, forced cooling will be required)							
	Storage Temperature		-20 °C ~ 65 °C							
	Humidity		0 ~ 90% RH (non-condensing)							
	Vibration		9.80665 m/s ² (1G) less than 20Hz, 5.88 m/s ² (0.6G) 20 to 50Hz							
	IP Rating		IP20							
Power System		TN System ^{*3,4}								
Approvals		IEC/EN 61800-5-1, UL 61800-5-1,  								

Note: *1. When it is with the rated load, the speed ratio is: the minimum speed (smooth operation) / rated speed.

*2. When the command is the rated speed, the velocity correction ratio is: (free run speed - full load speed) / rated speed

*3. TN system: The neutral point of the power system connects to the ground directly. The exposed metal components connect to the ground via the protective earth conductor.

*4. Use a single-phase three-wire power systems for models of single-phase power

Ordering Information

Servo Drive Dimensions

Frame A

100W / 200W

Weight
0.84 kg

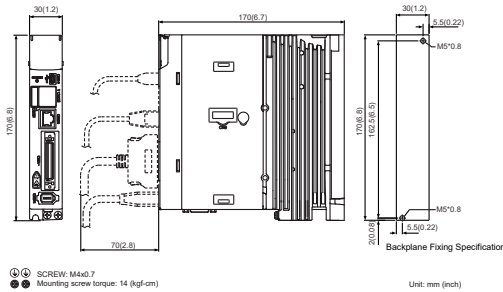

-L

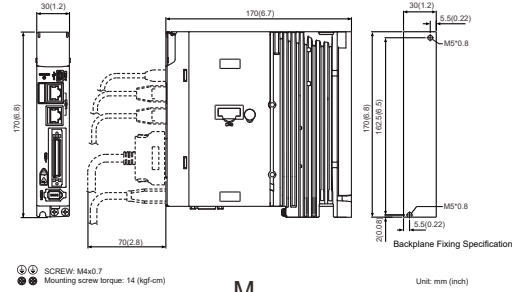

-M

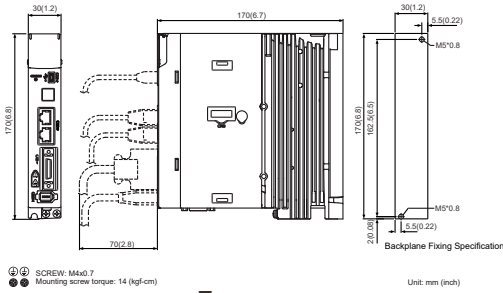

-F

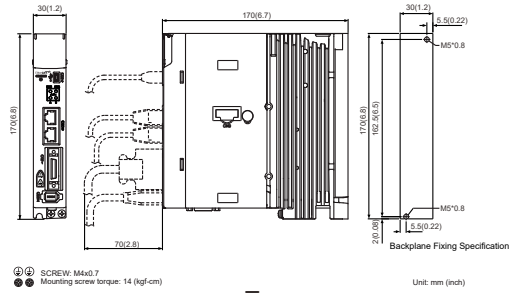

-E

Frame B

400W

Weight
0.92kg

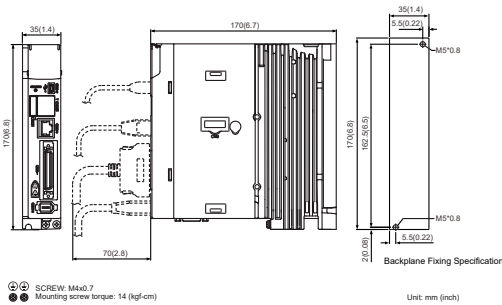

-L

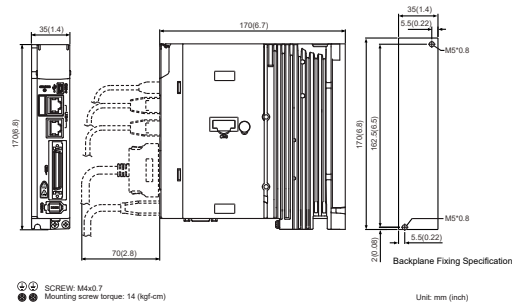

-M

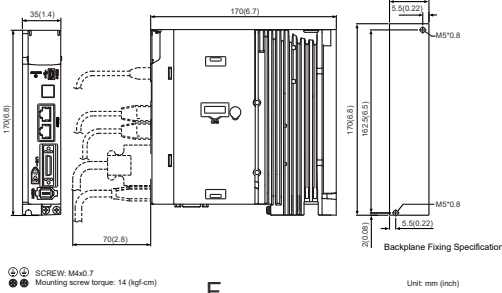

-F

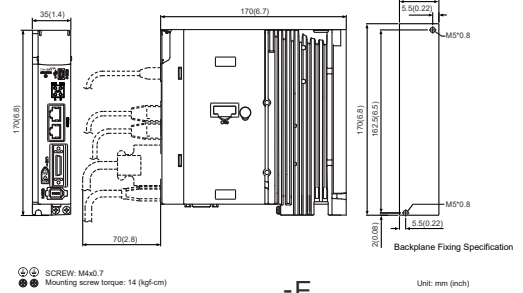

-E

Note:

1. Dimensions are in millimeters (inches); Weights are in kilograms (kg) and pounds (lbs).
2. Dimensions and weights of the servo drive may be revised without prior notice.

Frame C

750 W / 1 kW / 1.5 kW

Weight
1.3kg

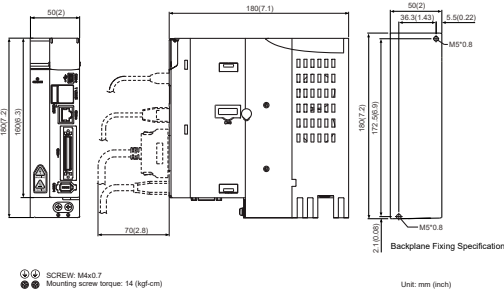

-L

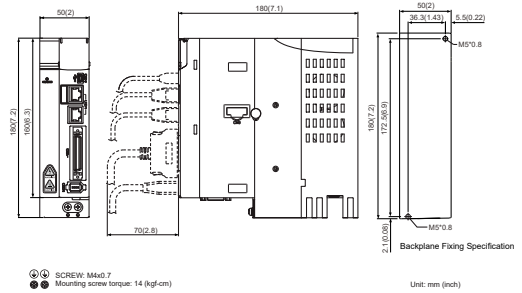

-M

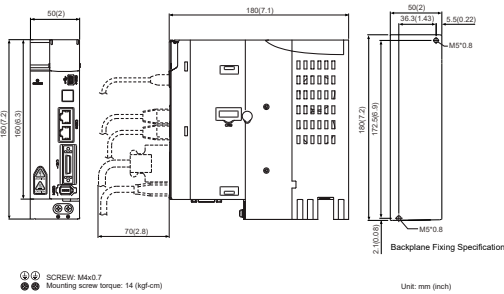

-F

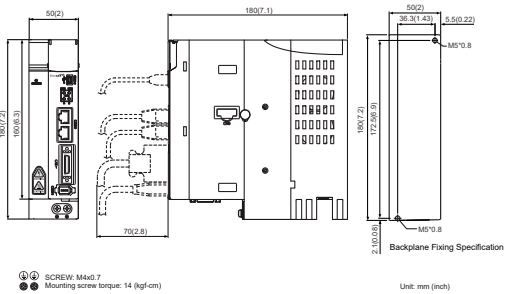

-E

2 kW / 3 kW

Weight
2.7kg

Frame D

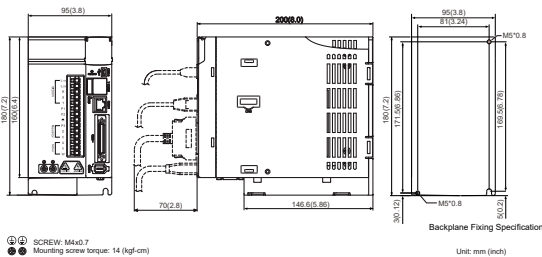

-L

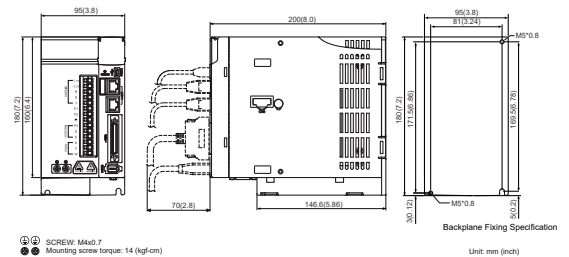

-M

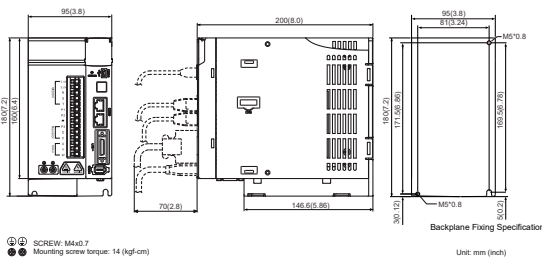

-F

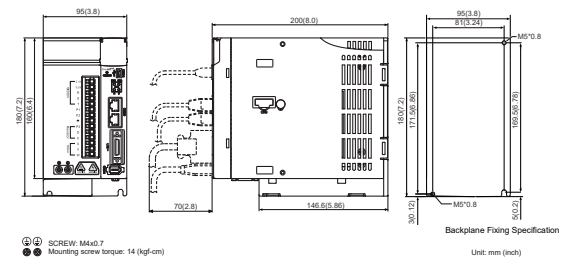

-E

Note:
1. Dimensions are in millimeters (inches); Weights are in kilograms (kg) and pounds (lbs).
2. Dimensions and weights of the servo drive may be revised without prior notice.

Ordering Information

Model Name Explanation

ECM-A3 Series Servo Motors

ECM - A 3 H - C Y 06 04 R S 1

Product Name
ECM: Electrical Commutation Motor

Driving Type
A: A Series

Generation
3: 3rd Generation

Inertia
H: High inertia
L: Low inertia

Series Rated Voltage / Rated Speed
C: Rated Voltage 220 V
Rated Speed 3,000 r/min

Encoder Type
Y: 24-bit Absolute Optical Encoder
Single-turn: 24-bit
Multi-turn: 16-bit
1: 24-bit Single-turn Absolute Optical Encoder
G: 16-bit Single-turn Absolute Magnetic Encoder
2: 24-bit Single-turn Absolute Magnetic Optical Encoder
A: 24-bit Absolute Magnetic Optical Encoder
Single-turn: 24-bit
Multi-turn: 16-bit

Motor Frame Size
04: 40 mm
06: 60 mm
08: 80 mm

Special digit
1: standard product

Shaft size
S: Standard
7: special (14 mm)

Shaft and Oil Seal	W/O Brake W/O Oil Seal	With Brake W/O Oil Seal	W/O Brake With Oil Seal	With Brake With Oil Seal
Round Shaft (with screw hole)	-	-	C	D
Keyway (with screw hole)	P	Q	R	S

Rated Output Power
0F: 50 W
01: 100 W
02: 200 W
04: 400 W
07: 750 W

*To be launched



Servo Motor Specifications

Low Inertia Series- ECM-A3L

ECM-A3L Series	C104		C106		C108	
	0F	01	02	04	04	07
Rated output power (kW)	0.05	0.1	0.2	0.4	0.4	0.75
Rated torque (N-m) ^{*1}	0.159	0.32	0.64	1.27	1.27	2.39
Maximum torque (N-m)	0.557	1.12	2.24	4.45	4.44	8.36
Rated speed (r/min)	3000					
Maximum speed (r/min)	6000					
Rated current (Arms)	0.66	0.9	1.45	2.65	2.6	5.1
Maximum current (Arms)	2.82	3.88	6.2	10.1	10.6	20.6
Power rating (kW/s)	11	25.6	45.5	107.5	45.8	102.2
Rotor moment of inertia (x10 ⁻⁴ kg-m ²)(Without brake)	0.0229	0.04	0.09	0.15	0.352	0.559
Mechanical time constant (ms)	1.28	0.838	0.64	0.41	0.68	0.44
Torque constant (N-m/A)	0.241	0.356	0.441	0.479	0.488	0.469
Voltage constant-KE (mV/(r/min))	9.28	13.3	16.4	18.0	17.9	17
Armature resistance (Ohm)	12.1	9.47	4.9	2.27	1.6	0.6
Armature inductance (mH)	18.6	16.2	18.52	10.27	10.6	4.6
Electrical time constant (ms)	1.54	1.71	3.78	4.52	6.63	7.67
Insulation class	Class A (UL), Class B (CE)					
Insulation resistance	100 MΩ, DC 500V above					
Insulation strength	1.8k Vac, 1 sec					
Weight (kg)(without brake)	0.38	0.5	1.1	1.4	2.05	2.8
Weight (kg)(with brake)	0.68	0.8	1.6	1.9	2.85	3.6
Max. radial shaft load (N)	78	78	245	245	392	392
Max. thrust shaft load (N)	54	54	74	74	147	147
Power rating (kW/s)(with brake)	9.9	24	34.1	89.6	39.5	93
Rotor moment of inertia (x10 ⁻⁴ kg-m ²)(with brake)	0.0255	0.0426	0.12	0.18	0.408	0.614
Mechanical time constant (ms)(with brake)	1.44	0.892	0.85	0.5	0.78	0.48
Brake holding torque [N·m (min)] ^{*2}	0.32	0.32	1.3	1.3	2.5	2.5
Brake power consumption (at 20°C)[W]	6.1	6.1	7.2	7.2	8	8
Brake release time [ms (Max)]	20	20	20	20	20	20
Brake pull-in time [ms (Max)]	35	35	50	50	60	60
Vibration grade (μm)	V15					
Operating temperature (°C)	0°C ~ 40°C					
Storage temperature (°C)	-10°C ~ 80°C					
Operating humidity	20 to 90%RH (non-condensing)					
Storage humidity	20 to 90%RH (non-condensing)					
Vibration capacity	2.5G					
IP Rating	IP65 (when waterproof connectors are used, or when an oil seal is used to be fitted to the rotating shaft)					
Approvals	CE					

Note:

1. The rated torque is the permissible continuous torque at the operation temperature of 0~40°C when the following heat sink is applied:

ECM-A3: _04/06/08 : 250 mm x 250mm x 6mm

Material type: Aluminum- F40, F60, F80

2. The built-in brake of the servo motor is for calmping the shaft. Never use it for decelerating or stopping the motor

Ordering Information

Servo Motor Specifications

High Inertia Series- ECM-A3H

ECM-A3H Series	C104		C106		C108	
	0F	01	02	04	04	07
Rated output power (kW)	0.05	0.1	0.2	0.4	0.4	0.75
Rated torque (N-m) ¹	0.159	0.32	0.64	1.27	1.27	2.39
Maximum torque (N-m)	0.557	1.12	2.24	4.45	4.44	8.36
Rated speed (r/min)	3000					
Maximum speed (r/min)	6000					
Rated current (Arms)	0.64	0.9	1.45	2.65	2.6	4.61
Maximum current (Arms)	2.59	3.64	5.4	9.8	9.32	16.53
Power rating (kW/s)	5.56	13.6	16.4	35.8	17.5	37.8
Rotor moment of inertia (x10 ⁻⁴ kg-m ²)(Without brake)	0.0455	0.0754	0.25	0.45	0.92	1.51
Mechanical time constant (ms)	2.52	1.43	1.38	0.96	1.32	0.93
Torque constant (N-m/A)	0.248	0.356	0.441	0.479	0.49	0.52
Voltage constant-KE (mV/(r/min))	9.54	12.9	16.4	17.2	17.9	18.7
Armature resistance (Ohm)	12.5	8.34	3.8	1.68	1.19	0.57
Armature inductance (mH)	13.34	11	8.15	4.03	4.2	2.2
Electrical time constant (ms)	1.07	1.32	2.14	2.40	3.53	3.86
Insulation class	Class A (UL), Class B (CE)					
Insulation resistance	100 MΩ, DC 500 V above					
Insulation strength	1.8k Vac, 1 sec					
Weight (kg)(without brake)	0.38	0.5	1.1	1.4	2.05	2.8
Weight (kg)(with brake)	0.68	0.8	1.6	1.9	2.85	3.6
Max. radial shaft load (N)	78	78	245	245	392	392
Max. thrust shaft load (N)	54	54	74	74	147	147
Power rating (kW/s)(with brake)	4.89	12.5	14.6	33.6	15.07	34.41
Rotor moment of inertia (x10 ⁻⁴ kg-m ²)(with brake)	0.0517	0.0816	0.28	0.48	1.07	1.66
Mechanical time constant (ms)(with brake)	2.86	1.55	1.54	1.02	1.54	1.02
Brake holding torque [Nt-m (min)] ²	0.32	0.32	1.3	1.3	2.5	2.5
Brake power consumption (at 20°C)[W]	6.1	6.1	7.2	7.2	8	8
Brake release time [ms (Max)]	20	20	20	20	20	20
Brake pull-in time [ms (Max)]	35	35	50	50	60	60
Vibration grade (μm)	V15					
Operating temperature (°C)	0°C ~ 40°C					
Storage temperature (°C)	-10°C ~ 80°C					
Operating humidity	20 to 90%RH (non-condensing)					
Storage humidity	20 to 90%RH (non-condensing)					
Vibration capacity	2.5G					
IP Rating	IP65 (when waterproof connectors are used, or when an oil seal is used to be fitted to the rotating shaft)					
Approvals						

Note:

1. The rated torque is the permissible continuous torque at the operation temperature of 0~40°C when the following heat sink is applied:

ECM-A3: 04/06/ 08 : 250 mm x 250mm x 6mm

Material type: Aluminum- F40, F60, F80

2. The built-in brake of the servo motor is for calmping the shaft. Never use it for decelerating or stopping the motor

Servo Motor Dimensions

ECM-A3 Series

Frame Size 80 mm and Below

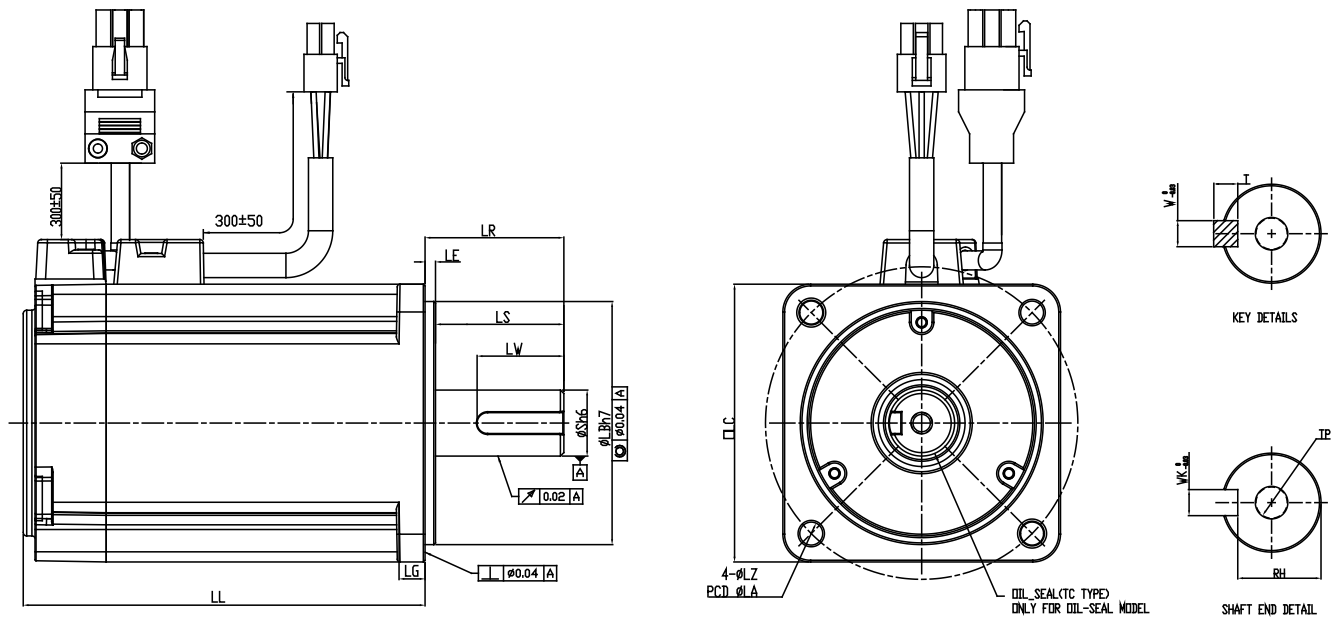

Units: mm

Model	C 1 040F 2 S 3 ^{*1}	C 1 0401 2 S 3	C 1 0602 2 S 3	C 1 0604 2 S 3	C 1 0804 2 7 3	C 1 0807 2 S 3 ^{*2}
LC	40	40	60	60	80	80
LZ	4.5	4.5	5.5	5.5	6.6	6.6
LA	46	46	70	70	90	90
S	8 (⁺⁰ / _{0.009})	8 (⁺⁰ / _{0.009})	14 (⁺⁰ / _{0.011})	14 (⁺⁰ / _{0.011})	14 (⁺⁰ / _{0.011})	19 (⁺⁰ / _{0.013})
LB	30 (⁺⁰ / _{0.021})	30 (⁺⁰ / _{0.021})	50 (⁺⁰ / _{0.025})	50 (⁺⁰ / _{0.025})	70 (⁺⁰ / _{0.03})	70 (⁺⁰ / _{0.03})
LL(without brake)	70.6	85.3	84	106	93.7	115.8
LL(with brake)	105.4	120.1	117.6	139.7	131.2	153.2
LS	21.5	22.5	27	27	27	37
LR	25	25	30	30	30	40
LE	2.5	2.5	3	3	3	3
LG	5	5	7.5	7.5	8	8
LW	16	16	20	20	20	25
RH	6.2	6.2	11	11	11	15.5
WK	3	3	5	5	5	6
W	3	3	5	5	5	6
T	3	3	5	5	5	6
TP	M3 Depth 6	M3 Depth 6	M4 Depth 8	M4 Depth 8	M4 Depth 8	M6 Depth 10

Note:
^{*1}. In servo motor model names, [1] signifies encoder type, [2] signifies shaft diameter and oil seal, and [3] signifies special code
^{*2}. When [3] of Model 807 is Z, LS=32, LR=35

Ordering Information

Speed-Torque Curves (T-N Curves)

ECM-A3 Torque Features

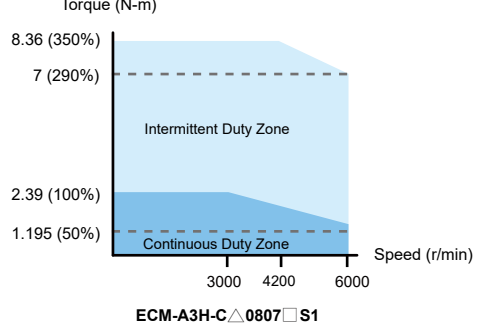
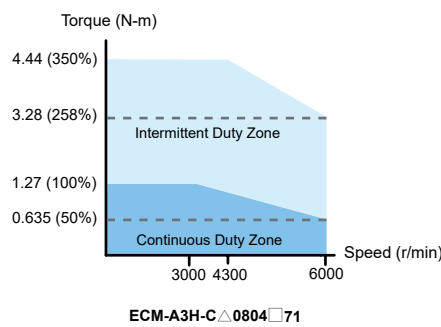
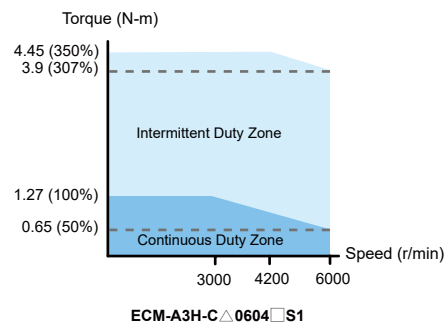
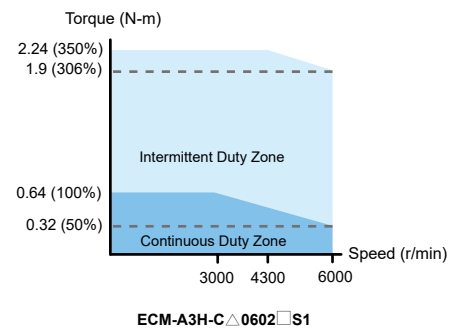
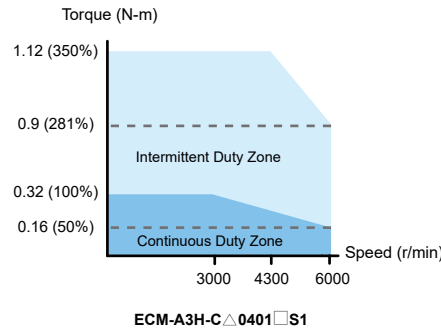
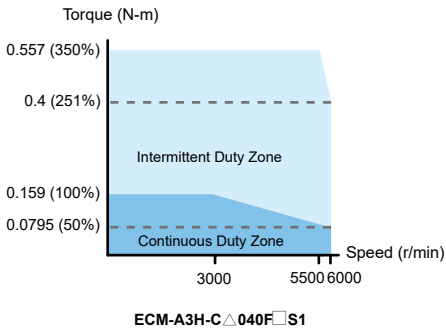
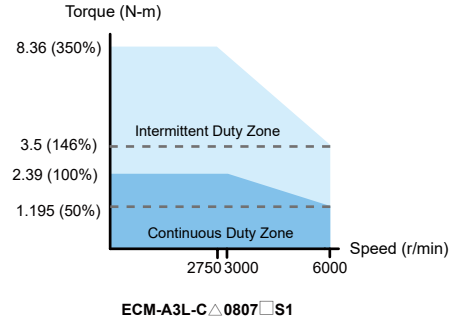
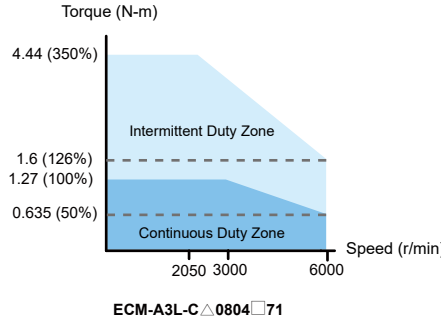
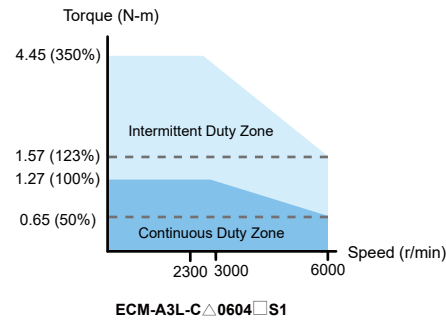
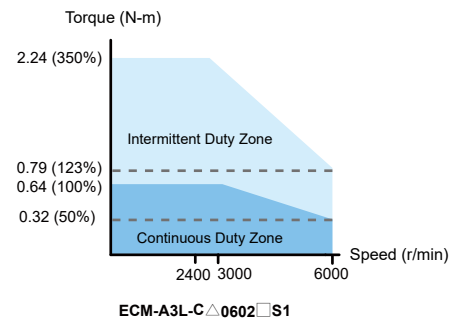
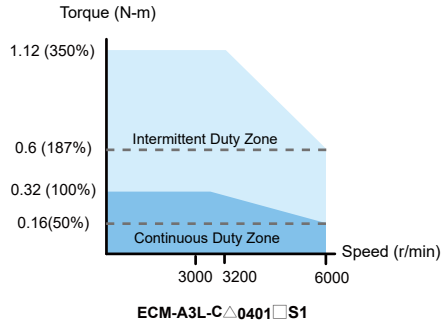
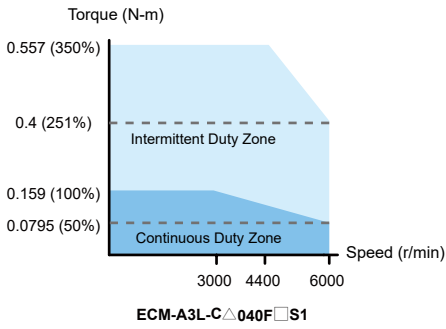

Model Name Explanation

ECMC Series Servo Motors

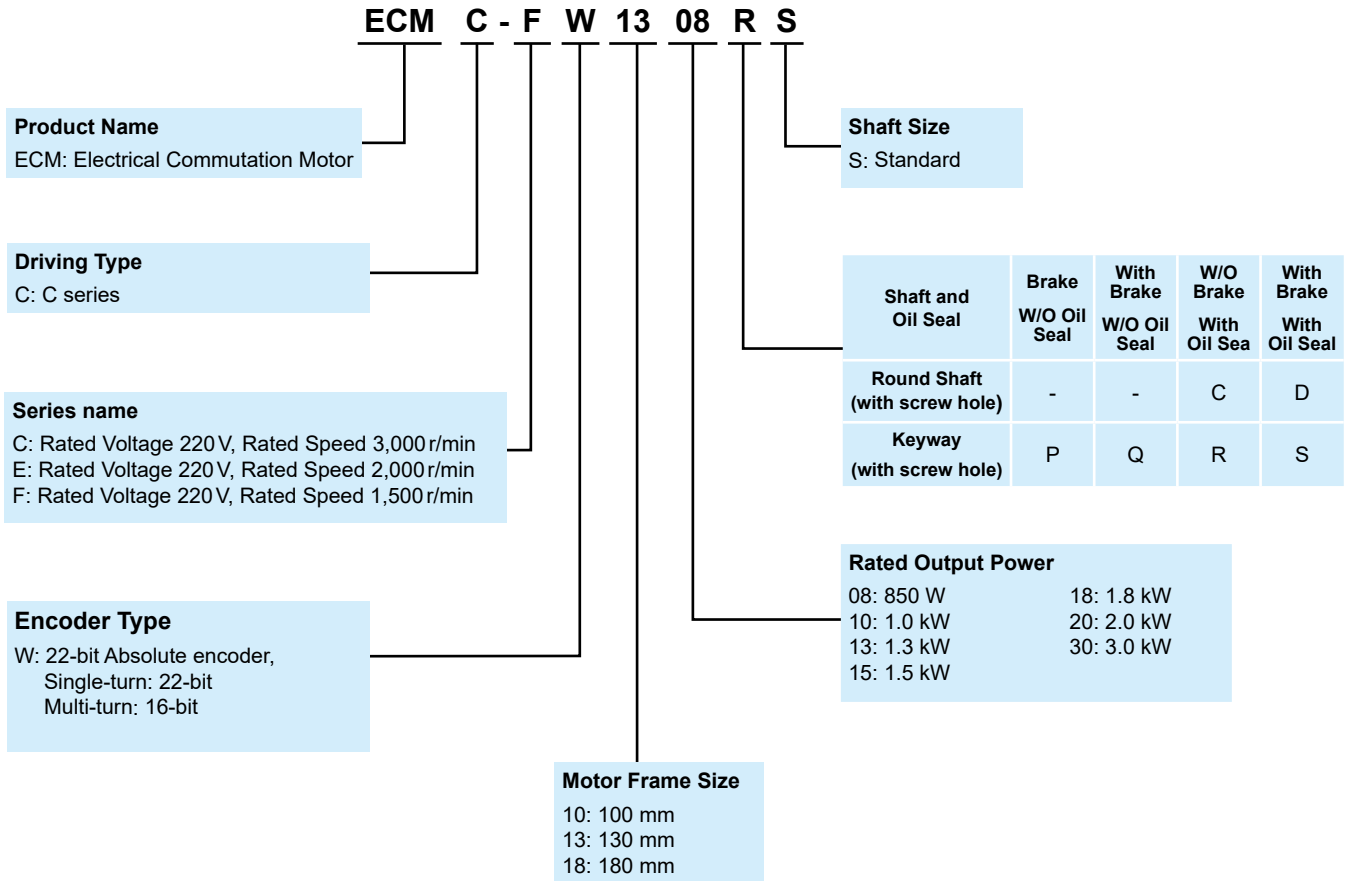

Ordering Information

Servo Motor Specifications

Medium Inertia ECMC Series - Frame Sizes 100~180 mm

ECMC Series	C10	E13			E18		F18	
	10	10	15	20	20	30	30	
Rated output power (kW)	1.0	1.0	1.5	2.0	2.0	3.0	3.0	
Rated torque (N-m) ¹	3.18	4.77	7.16	9.55	9.55	14.32	19.10	
Maximum torque (N-m)	9.54	14.3	21.5	28.7	28.7	43	57.3	
Rated speed (r/min)	3000	2000			2000		1500	
Maximum speed (r/min)	5000	3000			3000		3000	
Rated current (Arms)	7.3	5.6	8.3	11.01	11.2	16.1	19.4	
Maximum current (Arms)	21.9	16.8	24.9	33	33.7	48.3	58.2	
Power rating (kW/s)	38.1	27.1	45.9	62.5	26.3	37.3	66.4	
Rotor moment of inertia (x10 ⁻⁴ kg-m ²)(Without brake)	2.65	8.41	11.2	14.6	34.7	55	55	
Mechanical time constant (ms)	0.74	1.51	1.10	0.96	1.62	1.06	1.28	
Torque constant (N-m/A)	0.44	0.85	0.87	0.87	0.85	0.89	0.98	
Voltage constant-KE (mV/(r/min))	16.8	31.9	31.8	31.8	31.4	32.0	35	
Armature resistance (Ohm)	0.20	0.47	0.26	0.174	0.119	0.052	0.077	
Armature inductance (mH)	1.81	5.99	4.01	2.76	2.84	1.38	1.27	
Electrical time constant (ms)	9.3	12.9	15.3	15.9	23.9	26.4	16.5	
Insulation class	Class A (UL), Class B (CE)							
Insulation resistance	100 MΩ, DC 500V above							
Insulation strength	1.8k Vac, 1 sec							
Weight (kg)(without brake)	4.3	7.0	7.5	7.8	13.5	18.5	18.5	
Weight (kg)(with brake)	4.7	8.4	8.9	9.2	17.5	22.5	22.5	
Max. radial shaft load (N)	490				1176	1470		
Max. thrust shaft load (N)	98				490			
Power rating (kW/s)(with brake)	30.4	24.9	43.1	57.4	24.1	35.9	63.9	
Rotor moment of inertia (x10 ⁻⁴ kg-m ²)(with brake)	3.33	9.14	11.9	15.9	37.8	57.1	57.1	
Mechanical time constant (ms)(with brake)	0.93	1.64	1.19	1.05	1.77	1.10	1.33	
Brake holding torque [Nt-m (min)] ²	8	10			25			
Brake power consumption (at 20°C)[W]	18.7	19			20.4			
Brake release time [ms (Max)]	10							
Brake pull-in time [ms (Max)]	70							
Vibration grade (μm)	V15							
Operating temperature (°C)	0°C ~ 40°C (32°F ~ 104°F)							
Storage temperature (°C)	-10°C ~ 80°C (-14°F ~ 176°F)							
Operating humidity	20 to 90%RH (non-condensing)							
Storage humidity	20 to 90%RH (non-condensing)							
Vibration capacity	2.5G							
IP Rating	IP65 (when waterproof connectors are used, or when an oil seal is used to be fitted to the rotating shaft)							
Approvals								

Note:

1. □ in the servo model name signifies encoder type.

2. The rated torque is the permissible continuous torque at the operation temperature of 0~40°C when the following heat sink is applied:

ECMC- 10 : 300 mm x 300 mm x 12 mm

ECMC- 13 : 400 mm x 400 mm x 20 mm

ECMC- 18 : 550 mm x 550 mm x 30 mm

Material type: Aluminum- F100, F130, F180

3. The built-in brake of the servo motor is for calmping the shaft. Never use it for decelerating or stopping the motor

Servo Motor Dimensions

ECMC Series

Frame Sizes 100 / 130 mm

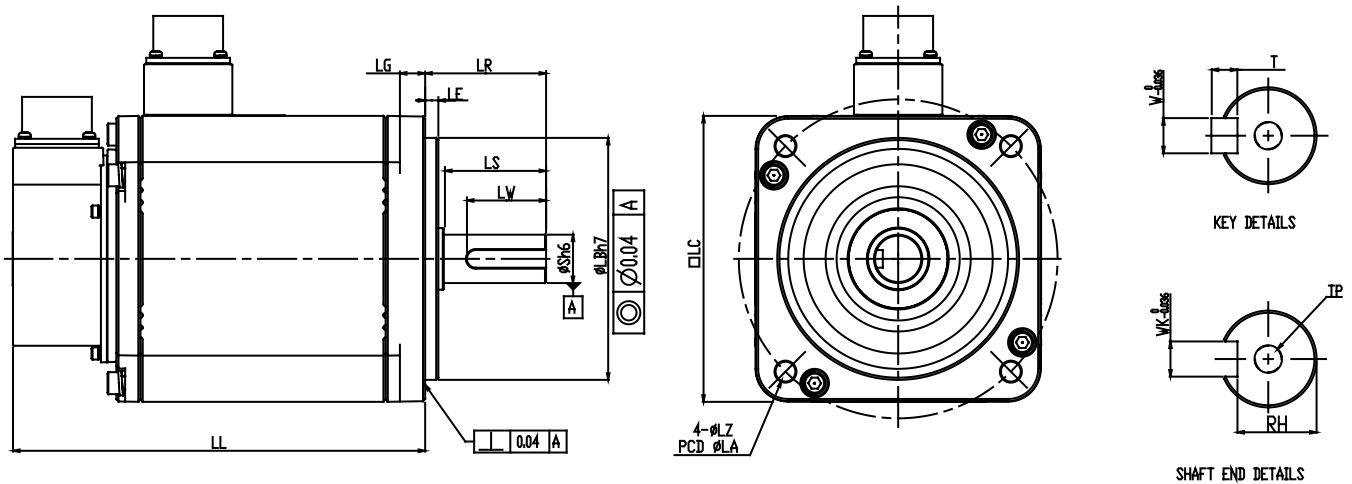

Units: mm

Model	C □ 1010 □ S ^{*1}	E □ 1310 □ S	E □ 1315 □ S	E □ 1320 □ S	F □ 1308 □ S	F □ 1313 □ S	F □ 1318 □ S
LC	100	130	130	130	130	130	130
LZ	9	9	9	9	9	9	9
LA	115	145	145	145	145	145	145
S	22 ($^{+0}_{-0.013}$)	22 ($^{+0}_{-0.013}$)	22 ($^{+0}_{-0.013}$)	22 ($^{+0}_{-0.013}$)	22 ($^{+0}_{-0.013}$)	22 ($^{+0}_{-0.013}$)	22 ($^{+0}_{-0.013}$)
LB	95 ($^{+0}_{-0.035}$)	110 ($^{+0}_{-0.035}$)	110 ($^{+0}_{-0.035}$)	110 ($^{+0}_{-0.035}$)	110 ($^{+0}_{-0.035}$)	110 ($^{+0}_{-0.035}$)	110 ($^{+0}_{-0.035}$)
LL(without brake)	153.3	147.5	167.5	187.5	152.5	187.5	202
LL(with brake)	192.5	183.5	202	216	181	216	230.7
LS	37	47	47	47	47	47	47
LR	45	55	55	55	55	55	55
LE	5	6	6	6	6	6	6
LG	12	11.5	11.5	11.5	11.5	11.5	11.5
LW	32	36	36	36	36	36	36
RH	18	18	18	18	18	18	18
WK	8	8	8	8	8	8	8
W	8	8	8	8	8	8	8
T	7	7	7	7	7	7	7
TP	M6 Depth 20	M6 Depth 20	M6 Depth 20	M6 Depth 20	M6 Depth 20	M6 Depth 20	M6 Depth 20

Note:

*1. In servo motor model names, □ signifies encoder type, □ signifies shaft diameter and oil seal

Ordering Information

Servo Motor Specifications

High Inertia ECMC Series -Frame Size 130 mm

ECMC Series	F13		
	08	13	18
Rated output power (kW)	0.85	1.3	1.8
Rated torque (N-m) ¹	5.41	8.34	11.48
Maximum torque (N-m)	13.8	23.3	28.7
Rated speed (r/min)	1500		
Maximum speed (r/min)	3000		
Rated current (Arms)	7.1	12.6	13
Maximum current (Arms)	19.4	38.6	36
Power rating (kW/s)	21.52	34.78	53
Rotor moment of inertia (x10 ⁻⁴ kg-m ²)(Without brake)	13.6	20	24.9
Mechanical time constant (ms)	2.43	1.62	1.7
Torque constant-KT (N-m/A)	0.76	0.66	0.88
Voltage constant-KE (mV/(r/min))	29.2	24.2	32.2
Armature resistance (Ohm)	0.38	0.124	0.185
Armature inductance (mH)	4.77	1.7	2.6
Electrical time constant (ms)	12.6	13.7	14.1
Insulation class	Class A (UL), Class B (CE)		
Insulation resistance	100 MΩ · DC 500V above		
Insulation strength	1.8k Vac, 1 sec		
Weight (kg)(without brake)	8.6	9.4	10.5
Weight (kg)(with brake)	10	10.8	11.9
Max. radial shaft load (N)	490		
Max. thrust shaft load (N)	98		
Power rating (kW/s)(with brake)	19.8	32.7	50.3
Rotor moment of inertia (x10 ⁻⁴ kg-m ²)(with brake)	14.8	21.3	26.2
Mechanical time constant (ms)(with brake)	2.65	1.73	1.79
Brake holding torque [Nt-m (min)] ²	10		
Brake power consumption (at 20°C)[W]	19		
Brake release time [ms (Max)]	10		
Brake pull-in time [ms (Max)]	70		
Vibration grade (μm)	V15		
Operating temperature (°C)	0°C ~ 40°C (32°F ~ 104°F)		
Storage temperature (°C)	-10°C ~ 80°C (-14°F ~ 176°F)		
Operating humidity	20 ~ 90%RH (non-condensing)		
Storage humidity	20 ~ 90%RH (non-condensing)		
Vibration capacity	2.5 G		
IP Rating	IP65 (when waterproof connectors are used, or when an oil seal is used to be fitted to the rotating shaft)		
Approvals			

Note:

1. □ in the servo model name signifies encoder type.

2. The rated torque is the permissible continuous torque at the operation temperature of 0~40°C when the following heat sink is applied:

ECMC-__10 : 300 mm x 300 mm x 12 mm

ECMC-__13 : 400 mm x 400 mm x 20 mm

ECMC-__18 : 550 mm x 550 mm x 30 mm

Material type: Aluminum- F100, F130, F180

3. The built-in brake of the servo motor is for calmping the shaft. Never use it for decelerating or stopping the motor

Servo Motor Dimensions

ECMC Series

Frame Size 180 mm

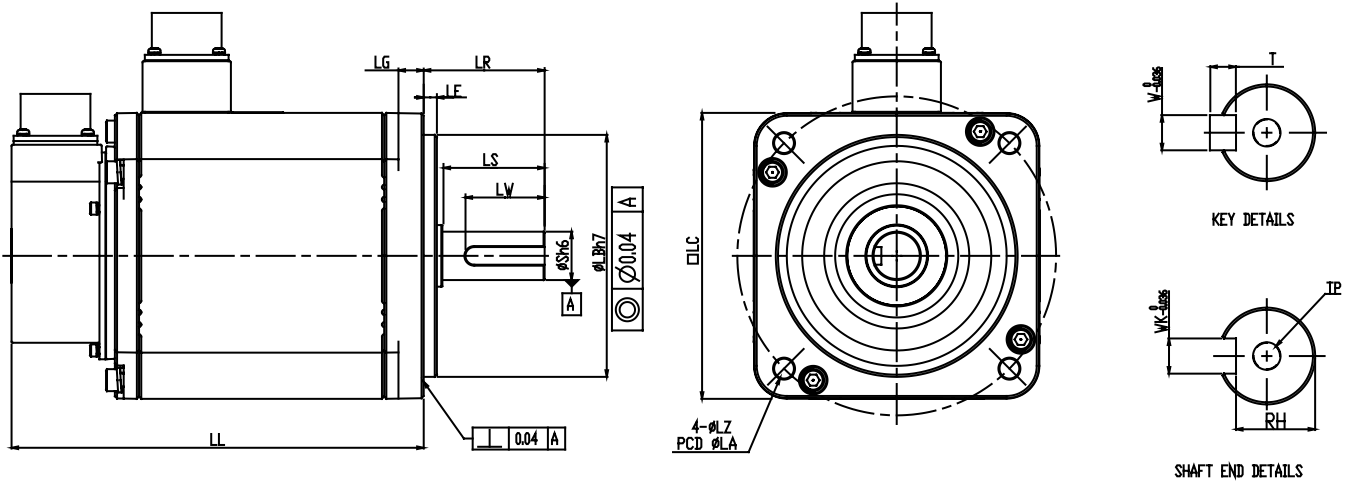

Units: mm

Model	E □ 1820 □ □ *1	E □ 1830 □ □	F □ 1830 □ □
LC	180	180	180
LZ	13.5	13.5	13.5
LA	200	200	200
S	35 ⁺⁰ / _{-0.016}	35 ⁺⁰ / _{-0.016}	35 ⁺⁰ / _{-0.016}
LB	114.3 ⁺⁰ / _{-0.035}	114.3 ⁺⁰ / _{-0.035}	114.3 ⁺⁰ / _{-0.035}
LL(without brake)	169	202.1	202.1
LL(with brake)	203.1	235.3	235.3
LS	73	73	73
LR	79	79	79
LE	4	4	4
LG	20	20	20
LW	63	63	63
RH	30	30	30
WK	10	10	10
W	10	10	10
T	8	8	8
TP	M12 Depth 25	M12 Depth 25	M12 Depth 25

Note:

*1. In servo motor model names, □ signifies encoder type, □ signifies shaft diameter and oil seal, and □ signifies special code

Ordering Information

Speed-Torque Curves (T-N Curves)

ECMC Torque Features

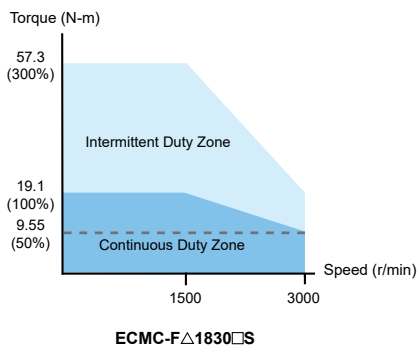
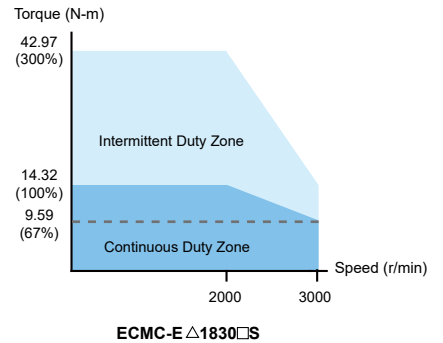
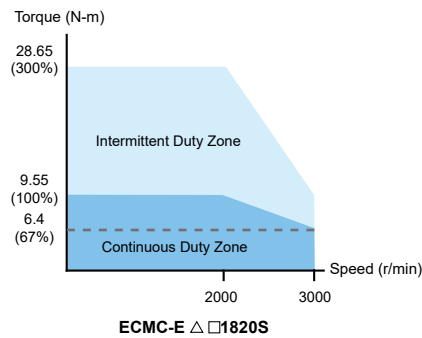
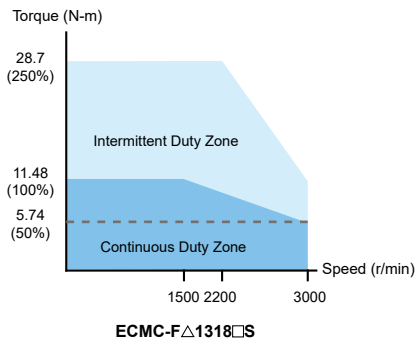
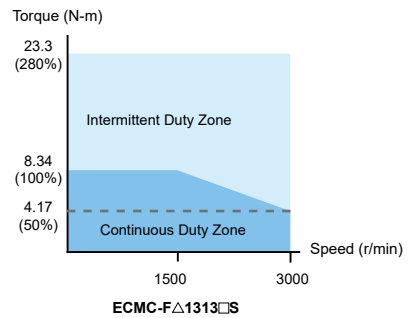
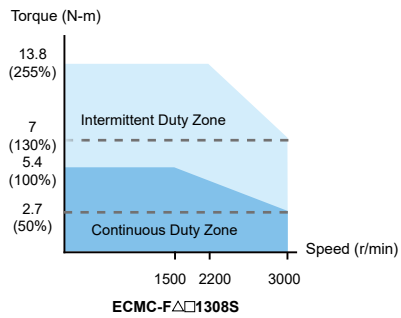
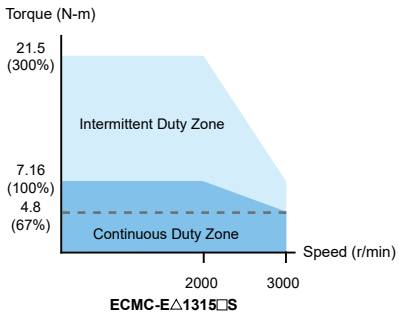
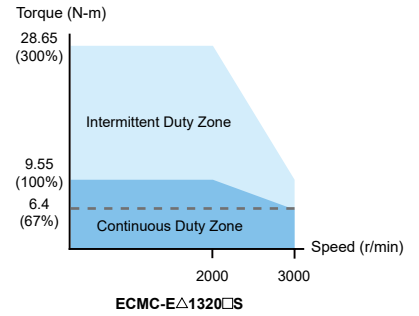
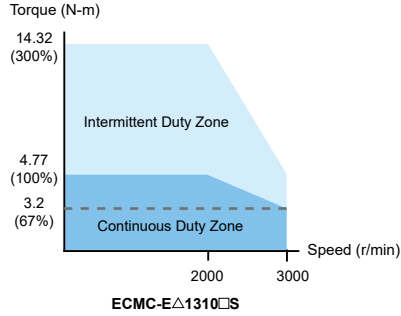
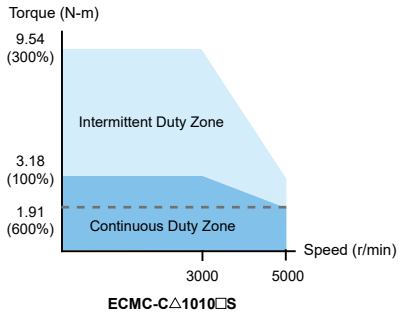

Optional Cables and Connectors

• Power Connectors

ASDBCAPW0000 (for 200V drives)

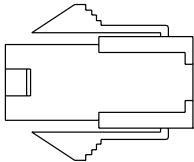

ASD-CAPW1000

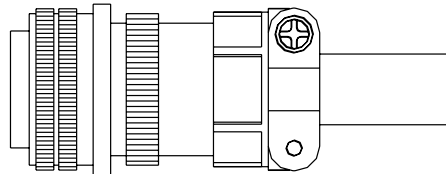

ASDBCAPW0100 (for 200V drives, with brake cable)

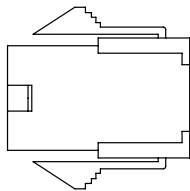

ASD-CAPW2000

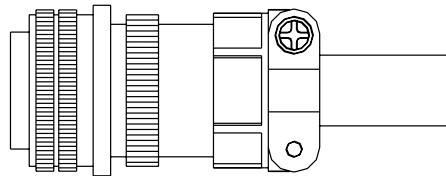

• Power Cables

ACS3-CAPW1103 · ACS3-CAPW1105 · ACS3-CAPW1110 · ACS3-CAPW1120 · ACS3-CAPF1103 · ACS3-CAPF1105 · ACS3-CAPF1110 · ACS3-CAPF1120 (for 200V drives)

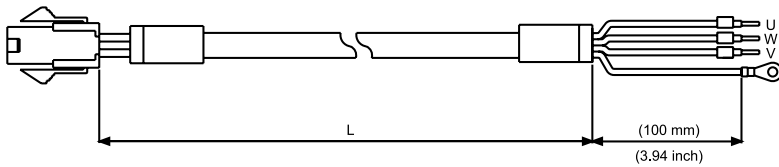

Cable	Part No.	L	
		mm	inch
Standard	ACS3-CAPW1103	3000 ± 50	118 ± 2
	ACS3-CAPW1105	5000 ± 50	197 ± 2
	ACS3-CAPW1110	10000 ± 100	398 ± 4
	ACS3-CAPW1120	20000 ± 100	788 ± 4
Flexible	ACS3-CAPF1103	3000 ± 50	118 ± 2
	ACS3-CAPF1105	5000 ± 50	197 ± 2
	ACS3-CAPF1110	10000 ± 100	394 ± 4
	ACS3-CAPF1120	20000 ± 100	788 ± 4

ACS3-CAPW2103 · ACS3-CAPW2105 · ACS3-CAPW2110 · ACS3-CAPW2120 · ACS3-CAPF2103 · ACS3-CAPF2105 · ACS3-CAPF2110 · ACS3-CAPF2120 (for 200V drives, with brake cable)

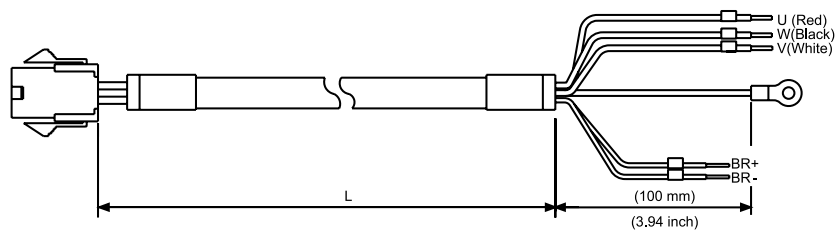

Cable	Part No.	L	
		mm	inch
Standard	ACS3-CAPW2103	3000 ± 50	118 ± 2
	ACS3-CAPW2105	5000 ± 50	197 ± 2
	ACS3-CAPW2110	10000 ± 100	394 ± 4
	ACS3-CAPW2120	20000 ± 100	788 ± 4
Flexible	ACS3-CAPF2103	3000 ± 50	118 ± 2
	ACS3-CAPF2105	5000 ± 50	197 ± 2
	ACS3-CAPF2110	10000 ± 100	394 ± 4
	ACS3-CAPF2120	20000 ± 100	788 ± 4

Ordering Information

Optional Cables and Connectors

- Power Cables

ACS3-CAPW1203, ACS3-CAPW1205

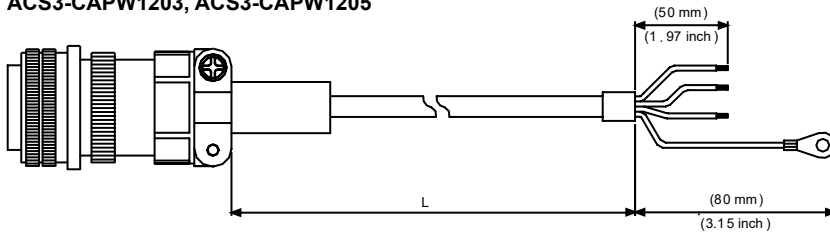

Cable	Part No.	Straight	L	
			mm	inch
Standard	ACS3-CAPW1203	3106A-20-18S	3000 ± 100	118 ± 4
	ACS3-CAPW1205	3106A-20-18S	5000 ± 100	197 ± 4

ACS3-CAPW2203, ACS3-CAPW2205 (with brake cable)

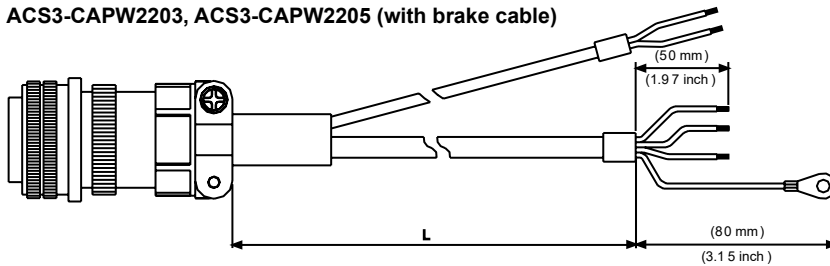

Cable	Part No.	Straight	L	
			mm	inch
Standard	ACS3-CAPW2203	3106A-20-18S	3000 ± 100	118 ± 4
	ACS3-CAPW2205	3106A-20-18S	5000 ± 100	197 ± 4

ACS3-CAPW1303, ACS3-CAPW1305

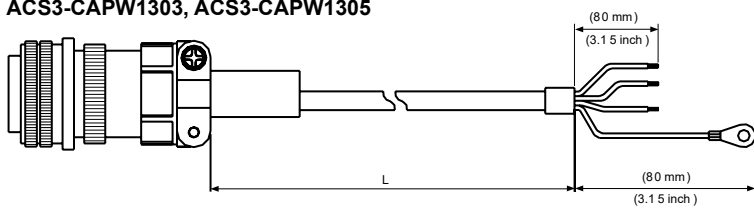

Cable	Part No.	Straight	L	
			mm	inch
Standard	ACS3-CAPW1303	3106A-20-18S	3000 ± 100	118 ± 4
	ACS3-CAPW1305	3106A-20-18S	5000 ± 100	197 ± 4

ACS3-CAPW2303, ACS3-CAPW2305 (with brake cable)

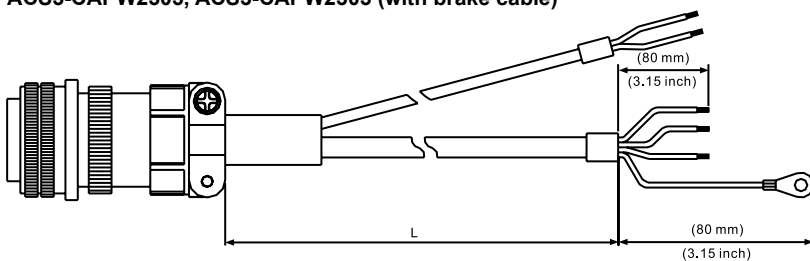

Cable	Part No.	Straight	L	
			mm	inch
Standard	ACS3-CAPW2303	3106A-20-18S	3000 ± 100	118 ± 4
	ACS3-CAPW2305	3106A-20-18S	5000 ± 100	197 ± 4

• Power Cables

ACS3-CAPW1403, ACS3-CAPW1405

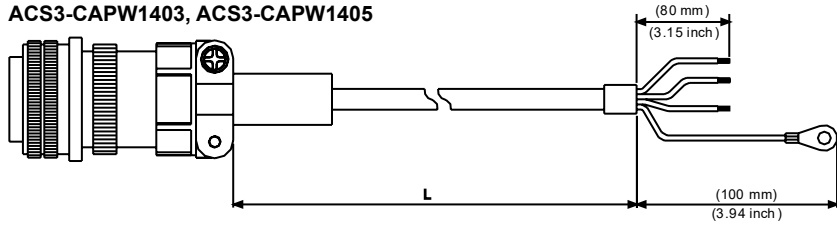

Cable	Part No.	Straight	L	
			mm	inch
Standard	ACS3-CAPW1403	3106A-24-11S	3000 ± 100	118 ± 4
	ACS3-CAPW1405	3106A-24-11S	5000 ± 100	197 ± 4

ACS3-CAPW2403, ACS3-CAPW2405 (with brake cable)

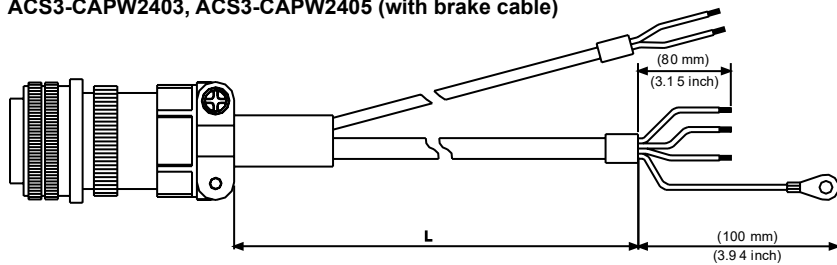

Cable	Part No.	Straight	L	
			mm	inch
Standard	ACS3-CAPW2403	3106A-24-11S	3000 ± 100	118 ± 4
	ACS3-CAPW2405	3106A-24-11S	5000 ± 100	197 ± 4

• Encoder Connectors

ACS3-CNEN1100

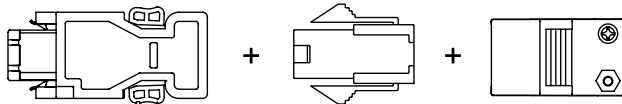

ACS3-CNENC200

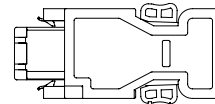

ACS3-CNEN3100

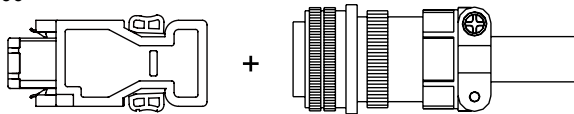

• Incremental Encoder Cables

ACS3-CAEF1003 · ACS3-CAEF1005 · ACS3-CAEF1010 · ACS3-CAEF1020

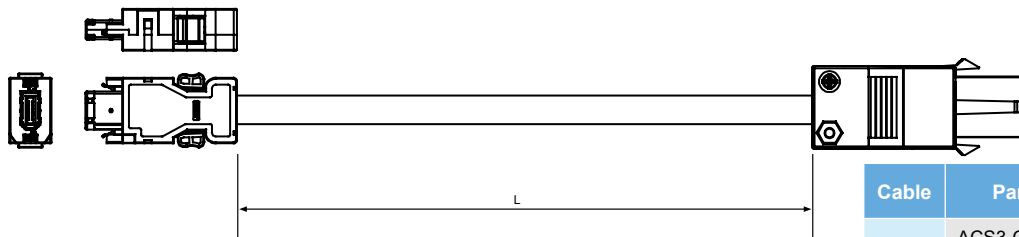

Cable	Part No.	L	
		mm	inch
Flexible	ACS3-CAEF1003	3000 ± 50	118 ± 2
	ACS3-CAEF1005	5000 ± 50	197 ± 2
	ACS3-CAEF1010	10000 ± 100	394 ± 4
	ACS3-CAEF1020	20000 ± 100	788 ± 4

Ordering Information

Optional Cables and Connectors

• Incremental Encoder Cables

ACS3-CAEF3003 · ACS3-CAEF3005 · ACS3-CAEF3010 · ACS3-CAEF3020

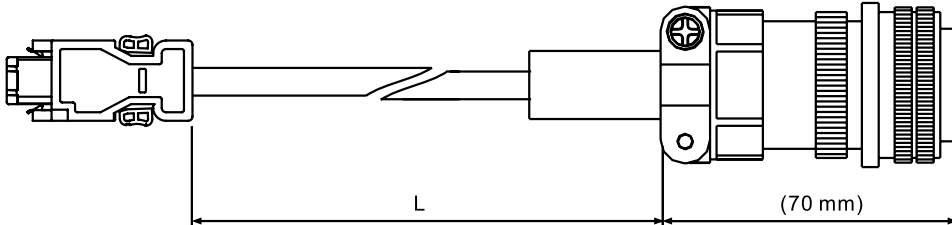

Cable	Part No.	Straight	L	
			mm	inch
Flexible	ACS3-CAEF3003	3106A-20-29S	3000 ± 50	118 ± 2
	ACS3-CAEF3005	3106A-20-29S	5000 ± 50	197 ± 2
	ACS3-CAEF3010	3106A-20-29S	10000 ± 100	394 ± 4
	ACS3-CAEF3020	3106A-20-29S	20000 ± 100	788 ± 4

• Absolute Encoder Cables

ACS3-CAEB1003 · ACS3-CAEB1005 · ACS3-CAEB1010 · ACS3-CAEB1020

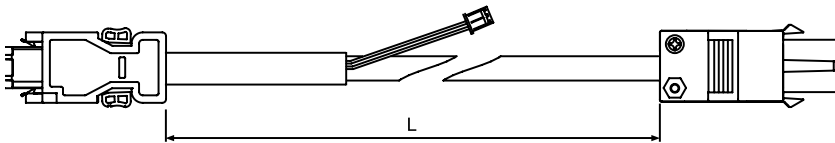

Cable	Part No.	L	
		mm	inch
Flexible	ACS3-CAEB1003	3000 ± 50	118 ± 2
	ACS3-CAEB1005	5000 ± 50	197 ± 2
	ACS3-CAEB1010	10000 ± 100	394 ± 4
	ACS3-CAEB1020	20000 ± 100	788 ± 4

ACS3-CAEB3003 · ACS3-CAEB3005 · ACS3-CAEB3010 · ACS3-CAEB3020

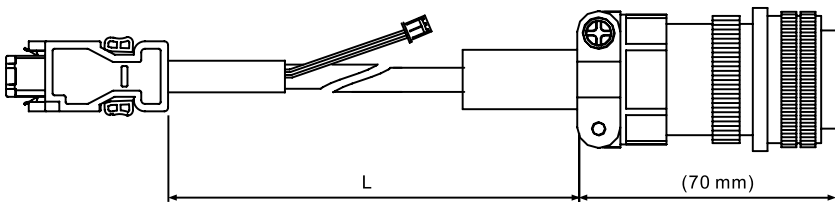

Cable	Part No.	L	
		mm	inch
Flexible	ACS3-CAEB3003	3000 ± 50	118 ± 2
	ACS3-CAEB3005	5000 ± 50	197 ± 2
	ACS3-CAEB3010	10000 ± 100	394 ± 4
	ACS3-CAEB3020	20000 ± 100	788 ± 4

• Battery Boxes with batteries Units: mm

Single Battery Box
ASD-MDBT0100

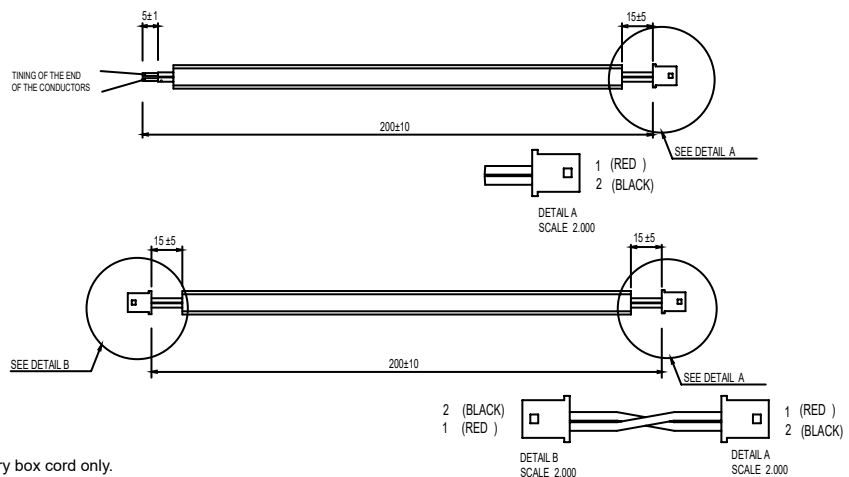
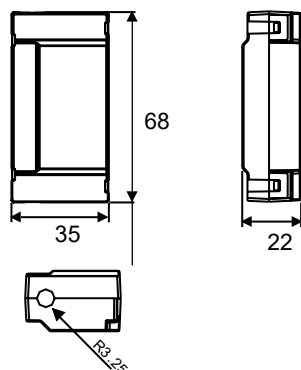

Please contact Delta Global Service team if ordering battery box cord only.

• **Battery Boxes with batteries** Units: mm

Dual Battery Box ASD-MDBT0200

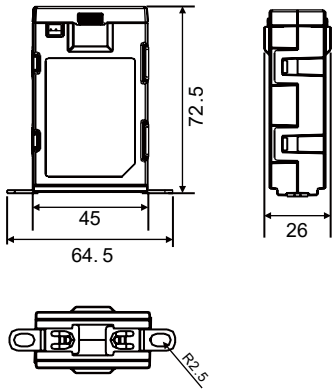

Please contact Delta Global Service team if ordering battery box cord only.

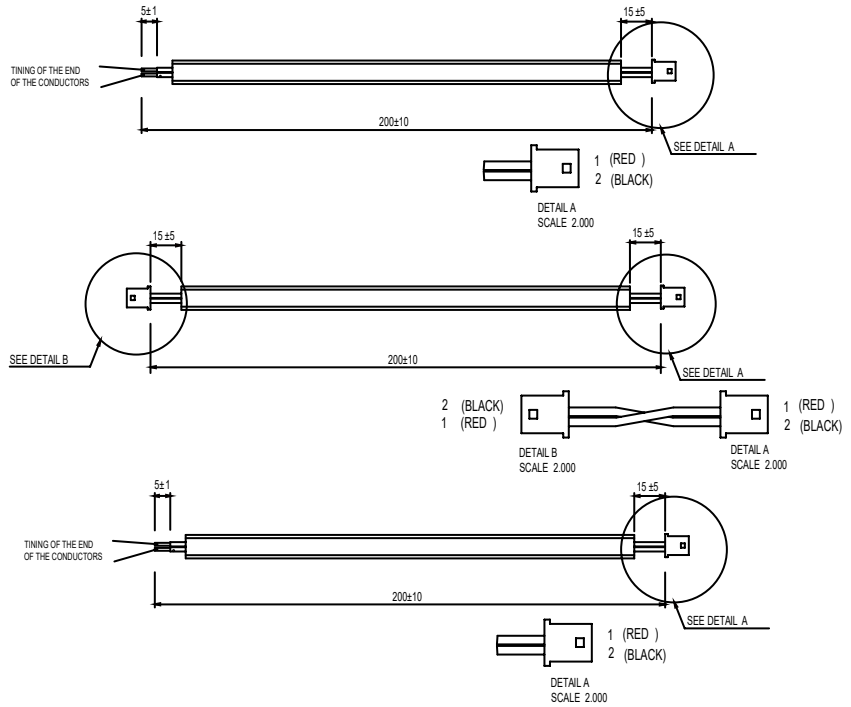

• **Terminal Block Module**

ACS3-MDTB5000

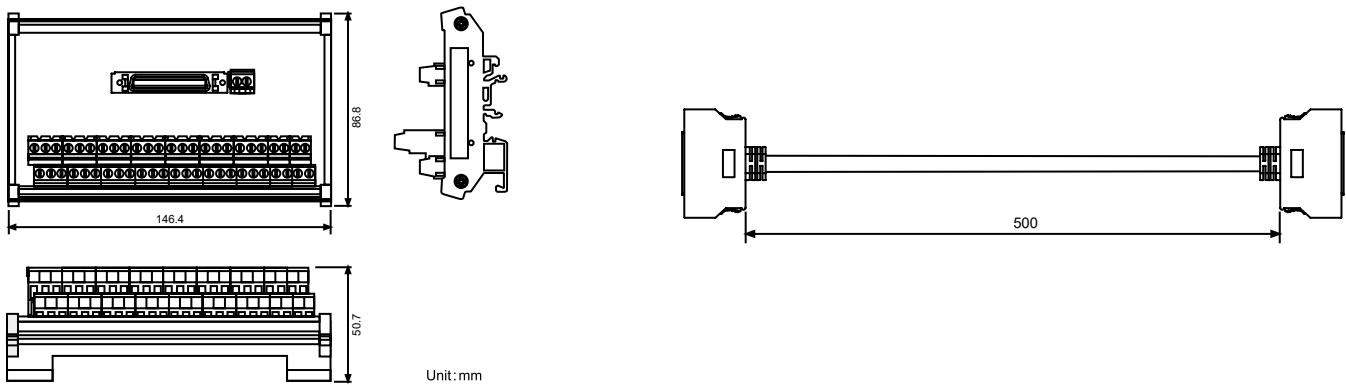

• **CANopen Communication Cable**

UC-CMC030-01A, UC-CMC050-01A L ±10

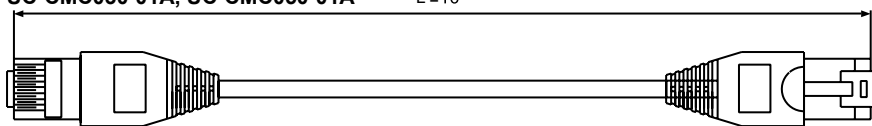

Item	Part No.	L	
		mm	inch
1	UC-CMC030-01A	3000 ± 10	11 ± 0.4
2	UC-CMC050-01A	5000 ± 10	19 ± 0.4

Ordering Information

Optional Cables and Connectors

- I/O Signal Connector (CN1)

ACS3-CNADC150

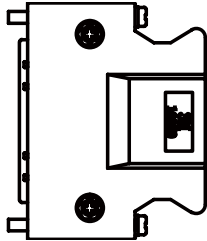

- Ferrite Rings

ASD-ACFC7K00

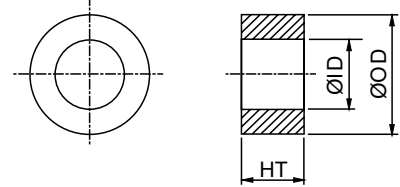

- CANopen Distribution Box Units: mm [inch]

TAP-CN03

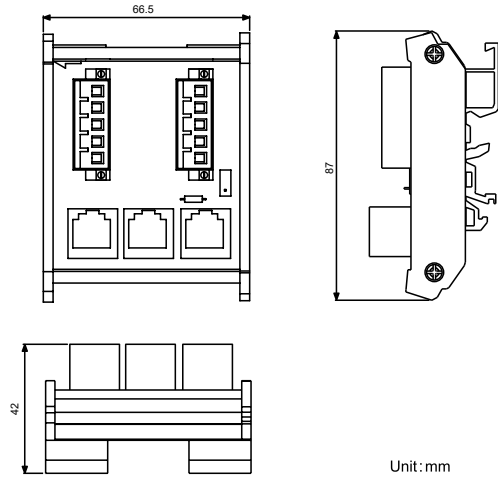

- A3 CN3 RS-485 Tap

ACS3-CNADC3RC

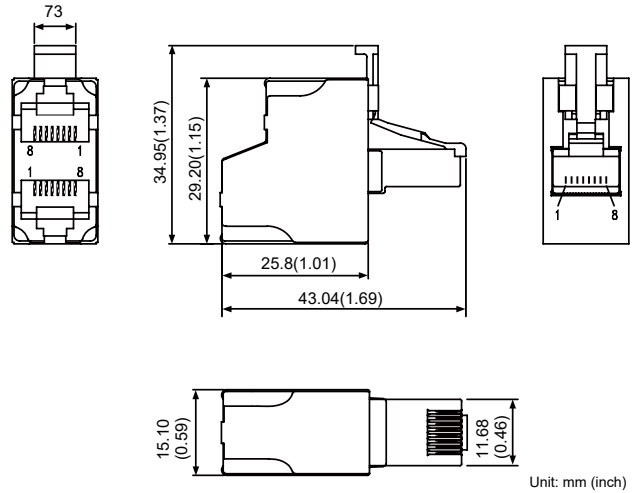

- A3 / A2 Adapter Cable

A3/A2 CN1 Adapter Cable
ACS3-CAADC1

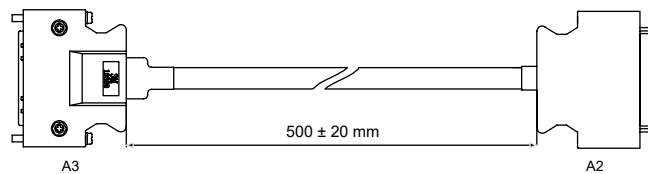

A3/A2 CN2 Adapter Cable
ACS3-CAADC2

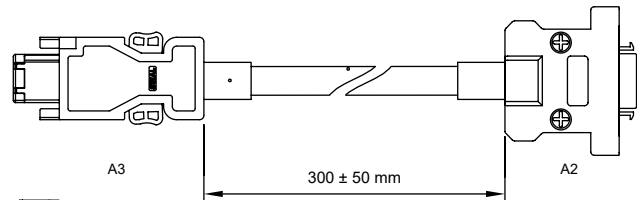

A3/A2 CN5 Adapter Cable
ACS3-CAADC5

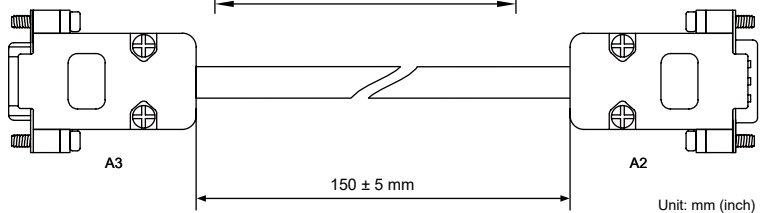

• **A3 CN3 RS-485 / CANOpen Termination Resistor**

ACS3-CNADC3TR

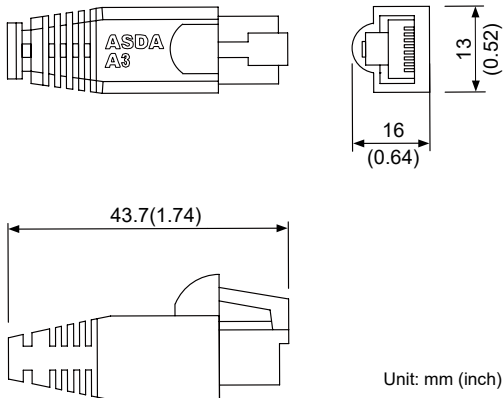

• **A3 CN6 DMCNET Termination Resistor**

ASD-TR-DM0008

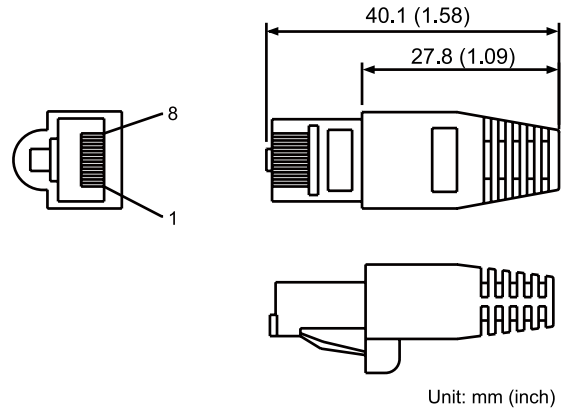

• **CN4 Mini USB Module**

UC-PRG015-01B, UC-PRG030-01B

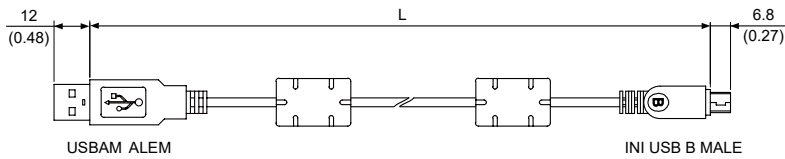
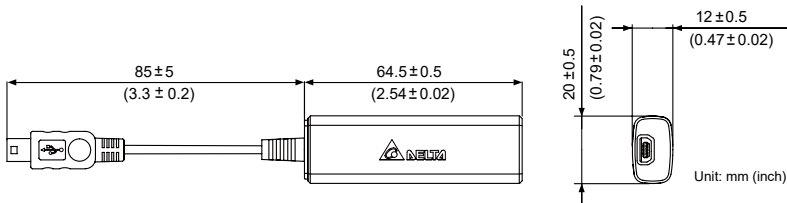

Item	Part No.	L	
		mm	inch
1	UC-PRG015-01B	1500 ± 100	59 ± 4
2	UC-PRG030-01B	3000 ± 100	118 ± 4

UC-ADP01-A

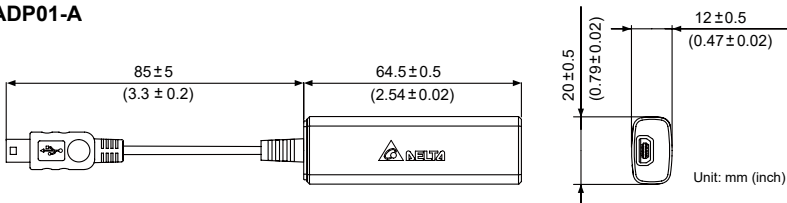

UC-PRG015-01A/ UC-PRG030-01A

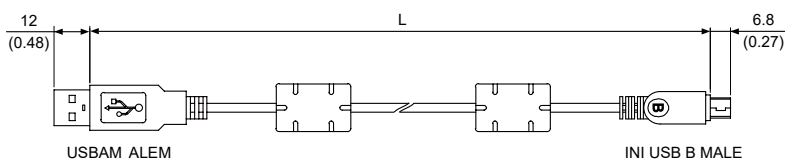

Item	Part No.	L	
		mm	inch
1	UC-PRG015-01A	1500 ± 100	59 ± 4
2	UC-PRG030-01A	3000 ± 100	118 ± 4