

Your motor and driver can be used together! Manufacturers of compatible motors: 18 companies

Mitsubishi Electric Corporation	YASKAWA Electric Corporation
SANYO DENKI CO., LTD.	OMRON Corporation
Panasonic Corporation	FANUC CORPORATION
NIDEC SANKYO CORPORATION	KEYENCE CORPORATION
FUJI ELECTRIC CO., LTD.	MinebeaMitsumi Inc.
Shinano Kenshi Co., Ltd.	ORIENTAL MOTOR Co., Ltd.
FASTECH Co., Ltd.	Rockwell Automation, Inc. (Allen-Bradley)
Beckhoff Automation GmbH	Siemens AG
Delta Electronics, Inc.	ANCA Motion

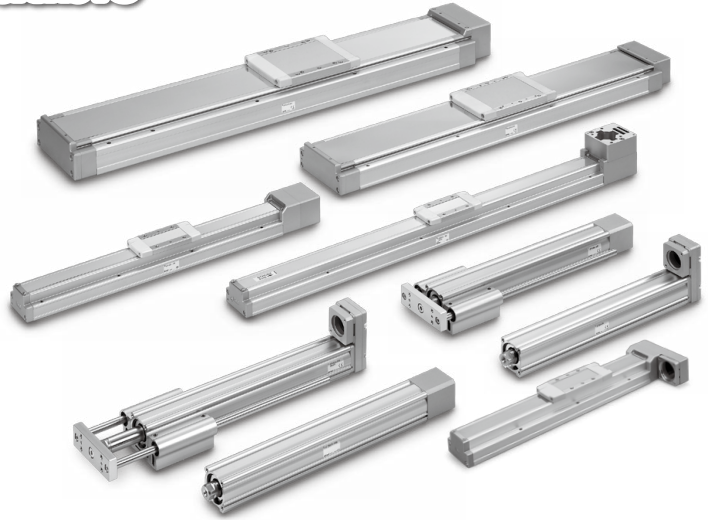

- LEFS
- LEFB
- LEJS
- LEJB
- LEL
- LEM
- LEY
- LEYG
- LES
- LESH
- LEPY
- LEPS
- LER
- LEH
- LEY-X5
- 11-LEFS
- 11-LEJS
- 25A-
- LEC□
- JXC□
- LECS□
- LECS□-T
- LECY□
- Motorless
- LAT3

Slider Type LEF Series

p. 819, 846

- An option without grease applied to the seal band part has been added. (Excludes the LEFB)
- Auto switches and mounting brackets have been added.
- Positioning pin holes (Body bottom 2 locations) have been added.

Ball Screw Drive/LEFS Series

Size	Stroke
25	50 to 800
32	50 to 1000
40	150 to 1200

Belt Drive/LEFB Series

Size	Stroke
25	300 to 2000
32	300 to 2500
40	300 to 3000

Belt Drive LEFB Series

Ball Screw Drive LEFS Series



High Rigidity Slider Type LEJ Series

p. 875

- Normally closed solid state auto switches have been added.

Ball Screw Drive/LEJS Series

Size	Stroke
40	200 to 1200
63	300 to 1500

Ball Screw Drive LEJS Series

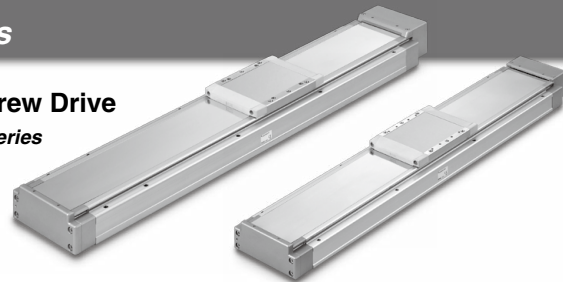

Rod Type LEY Series

p. 901

- Intermediate strokes have been added to the LEY63.
- Normally closed solid state auto switches have been added.

Size	Stroke
25	30 to 400
32	30 to 500
63	50 to 800



Guide Rod Type LEYG Series

p. 917

- Normally closed solid state auto switches have been added.

Size	Stroke
25	30 to 300
32	

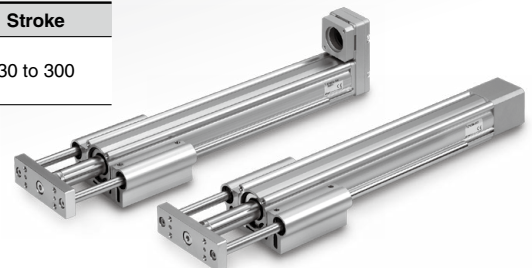



Compatible Motors by Manufacturer (100 W/200 W/400 W equivalent)

Manufacturer	Series	Type *1	Interface				
			Battery-less absolute encoder	Pulse input	CC-Link IE Field	CC-Link IE TSN	SSCNET III/H
Mitsubishi Electric Corporation	MELSERVO-JN	HF-KN		●			
	MELSERVO-J4	HG-KR		●	●		●
	MELSERVO-J5	HK-KT	●	●		●	
YASKAWA Electric Corporation	Σ-V	SGMJV		●			
	Σ-7	SGM7J/SGM7A	●	●			
SANYO DENKI CO., LTD.	SANMOTION R	R2		●			
OMRON Corporation	Sysmac G5	R88M-K		●			
	1 S	R88M-1	●	●			
Panasonic Corporation	MINAS A5	MSM□/MHMD		●			
	MINAS A6	MSMF/MHMF		●			
FANUC CORPORATION	βis (-B)	β		●			
NIDEC SANKYO CORPORATION	S-FLAG	MA/MH/MM		●			
KEYENCE CORPORATION	SV	SV-M/SV-B		●			
	SV2	SV2-M/SV2-B		●			
FUJI ELECTRIC CO., LTD.	ALPHA5	GYS/GYB		●			
	ALPHA7	GYS/GYB		●			
	FALDIC α	GYS		●			
MinebeaMitsumi Inc.	SZ	A17PM/A23KM		●			
Shinano Kenshi Co., Ltd.	CSB-BZ	CSB-BZ		●			
ORIENTAL MOTOR Co., Ltd.	AR	AR		●			
	AZ	AZ	●	●			
FASTECH Co., Ltd.	Ezi-SERVO	EzM		●			
Rockwell Automation, Inc. (Allen-Bradley)	MP-/VP-	MP/VP		●			
	TL	TLY-A		●			
Beckhoff Automation GmbH	AM	AM30/AM31		●			
	AM	AM80/AM81		●			
Siemens AG	1FK7	1FK7		●			
Delta Electronics, Inc.	ASDA-A2	ECMA		●			
ANCA Motion	AMD2000	Alpha		●			

*1 Make sure that the mounting dimensions and motor specifications are appropriate. Select a motor after checking the specifications of each model. Additionally, when considering a motor other than one of those shown above, select a motor within the range of the specifications after checking the mounting dimensions.

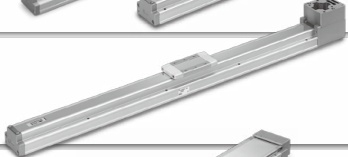
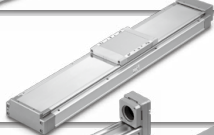
Series Variations

Series	Size				Page
	25	32	40	63	
Slider Type Ball Screw Drive <i>LEFS Series</i> 	100 W	200 W	400 W		819
Slider Type Belt Drive <i>LEFB Series</i> 	100 W	200 W	400 W		846
High Rigidity Slider Type Ball Screw Drive <i>LEJS Series</i> 			100 W	200 W	875
Rod Type <i>LEY Series</i> 	100 W	200 W		400 W	901
Guide Rod Type <i>LEYG Series</i> 	100 W	200 W			917

The values in ● show the equivalent motor capacity.

Motorless Type Electric Actuators

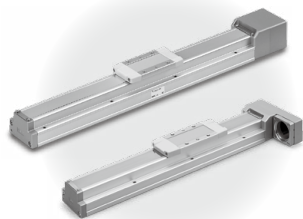

◎ Electric Actuator/Slider Type Ball Screw Drive

LEFS Series

Model Selection.....	p. 819
How to Order	p. 827
Specifications	p. 828
Dimensions	p. 829
Motor Mounting	p. 841
Motor Mounting Parts.....	p. 843

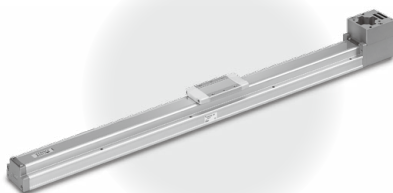

◎ Electric Actuator/Slider Type Belt Drive

LEFB Series

Model Selection.....	p. 846
How to Order	p. 851
Specifications	p. 852
Dimensions	p. 853
Motor Mounting	p. 865
Motor Mounting Parts.....	p. 866

Auto Switch Mounting	p. 868
Specific Product Precautions.....	p. 872

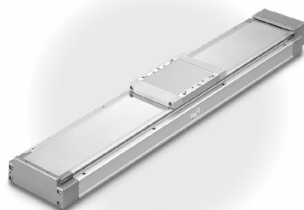

◎ Electric Actuator/High Rigidity Slider Type Ball Screw Drive

LEJS Series

Model Selection.....	p. 875
How to Order	p. 885
Specifications	p. 886
Dimensions	p. 887
Motor Mounting	p. 891
Motor Mounting Parts.....	p. 892

◎ LEJS-M (Built-in Intermediate Supports Type)

Model Selection.....	p. 875
How to Order	p. 889
Specifications	p. 889
Construction	p. 194
Dimensions	p. 890

Auto Switch Mounting	p. 894
Specific Product Precautions.....	p. 898



◎ Electric Actuator/Rod Type

LEYS Series

Model Selection.....	p. 901
How to Order	p. 907
Specifications	p. 908
Dimensions	p. 910



◎ Electric Actuator/Guide Rod Type

LEYG Series

Model Selection.....	p. 917
How to Order	p. 921
Specifications	p. 922
Dimensions	p. 923

Motor Mounting	p. 925
Motor Mounting Parts.....	p. 929
Auto Switch	p. 933
Specific Product Precautions.....	p. 937

Slider Type

Ball Screw Drive *LEFS Series*

p. 819



Belt Drive *LEFB Series*

p. 846



- LEFS
- LEFB
- LEJS
- LEJB
- LEL
- LEM
- LEY
- LEYG
- LES
- LESH
- LEPY
- LEPS
- LER
- LEH
- LEY-X5
- 11-LEFS
- 11-LEJS
- 25A-
- LEC
- JXC
- LECS
- LECS-T
- LECY
- Motorless
- LAT3

Motorless Type
Electric Actuator/Slider Type
Ball Screw Drive/LEFS Series
Model Selection

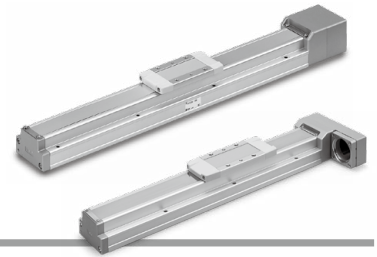

LEFS Series ▶ p. 827

Selection Procedure



Selection Example

The model selection method shown below corresponds to SMC's standard motor. For use in combination with a motor from a different manufacturer, check the available product information of the motor to be used.

Operating conditions

- Workpiece mass: 55 [kg]
- Speed: 300 [mm/s]
- Acceleration/Deceleration: 3000 [mm/s²]
- Stroke: 200 [mm]
- Mounting position: Horizontal upward
- Incremental encoder
- Workpiece mounting condition:
- Settling time

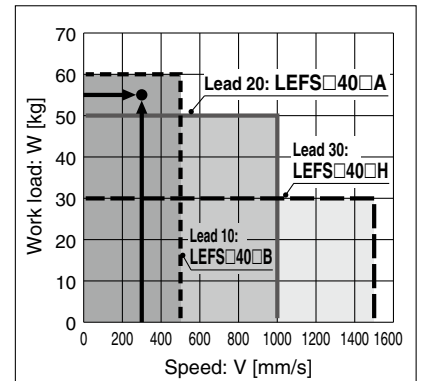
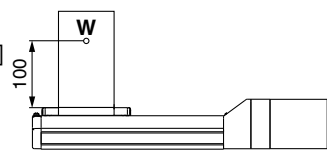

<Speed-Work Load Graph>
(LEFS40)

Step 1 Check the work load-speed. <Speed-Work Load Graph>

Select a model based on the workpiece mass and speed which are within the range of the actuator body specifications while referencing the speed-work load graph (guide) on page 820.

Selection example) The LEFS40B-200 can be temporarily selected as a possible candidate based on the graph shown on the right side.

* Refer to the selection method of motor manufacturers for regeneration resistance.

Step 2 Check the cycle time.

Calculate the cycle time using the following calculation method.

Cycle time:

T can be found from the following equation.

$$T = T1 + T2 + T3 + T4 [s]$$

• T1: Acceleration time and T3: Deceleration time can be found by the following equation.

$$T1 = V/a1 [s] \quad T3 = V/a2 [s]$$

• T2: Constant speed time can be found from the following equation.

$$T2 = \frac{L - 0.5 \cdot V \cdot (T1 + T3)}{V} [s]$$

• T4: Settling time varies depending on the motor type and load. The value below is recommended.

$$T4 = 0.05 [s]$$

* The conditions for the settling time vary depending on the motor or driver to be used.

Calculation example)

T1 to T4 can be calculated as follows.

$$T1 = V/a1 = 300/3000 = 0.1 [s],$$

$$T3 = V/a2 = 300/3000 = 0.1 [s]$$

$$T2 = \frac{L - 0.5 \cdot V \cdot (T1 + T3)}{V} = \frac{200 - 0.5 \cdot 300 \cdot (0.1 + 0.1)}{300} = 0.57 [s]$$

$$T4 = 0.05 [s]$$

The cycle time can be found as follows.

$$T = T1 + T2 + T3 + T4 = 0.1 + 0.57 + 0.1 + 0.05 = 0.82 [s]$$

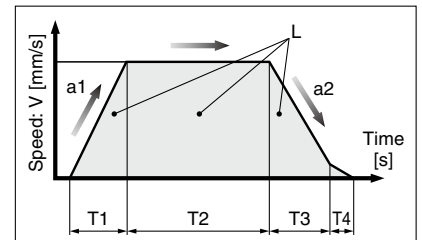

L : Stroke [mm]

... (Operating condition)

V : Speed [mm/s]

... (Operating condition)

a1: Acceleration [mm/s²]

... (Operating condition)

a2: Deceleration [mm/s²]

... (Operating condition)

T1: Acceleration time [s]

Time until reaching the set speed

T2: Constant speed time [s]

Time while the actuator is operating at a constant speed

T3: Deceleration time [s]

Time from the beginning of the constant speed operation to stop

T4: Settling time [s]

Time until positioning is completed

Step 3 Check the guide moment.

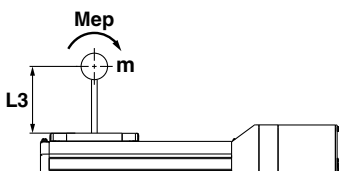

Based on the above calculation result, the LEFS40B-200 should be selected.

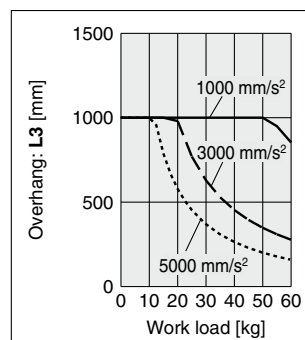

- * The values shown below are allowable values of the actuator body. Do not use the actuator so that it exceeds these specification ranges.
- * The allowable speed is restricted depending on the stroke. Select it by referring to the "Allowable Stroke Speed" below.

Speed-Work Load Graph (Guide)

LEFS□25/Ball Screw Drive

Horizontal

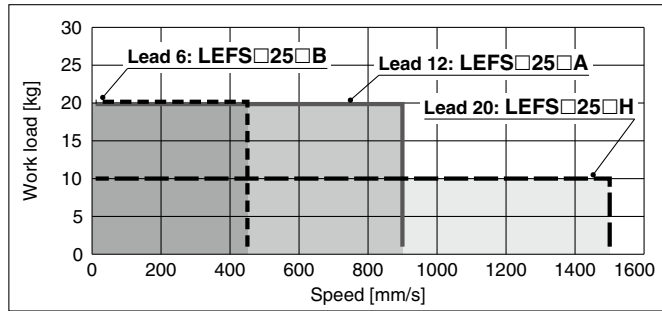

Vertical

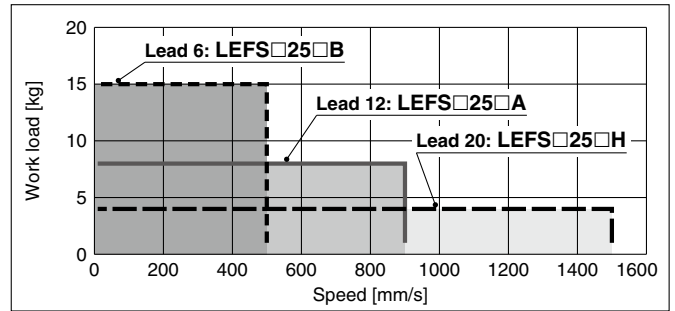

LEFS□32/Ball Screw Drive

Horizontal

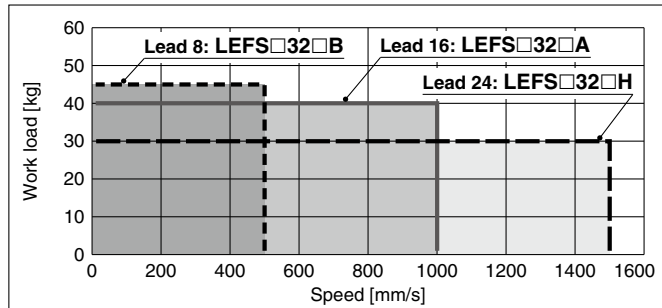

Vertical

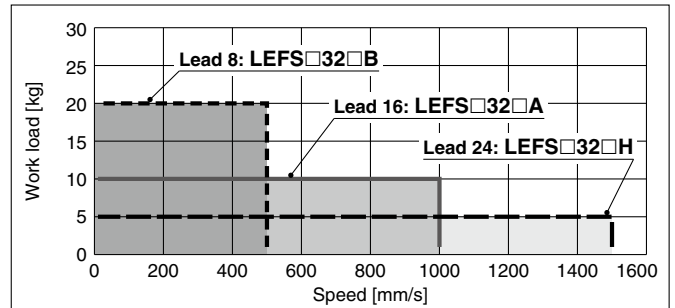

LEFS□40/Ball Screw Drive

Horizontal

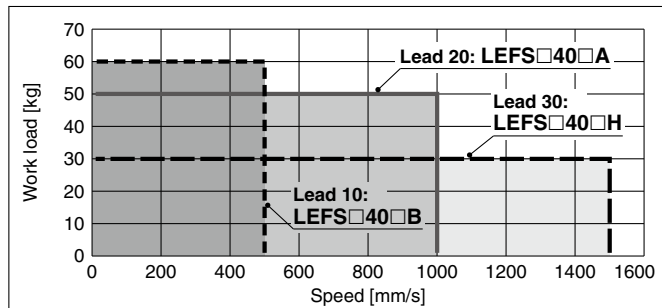

Vertical

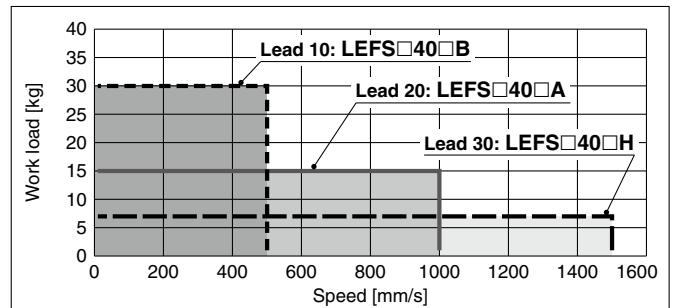

Allowable Stroke Speed

Model	AC servo motor	Lead		Stroke [mm]											
		Symbol	[mm]	Up to 100	Up to 200	Up to 300	Up to 400	Up to 500	Up to 600	Up to 700	Up to 800	Up to 900	Up to 1000	Up to 1100	Up to 1200
LEFS25	100 W equivalent	H	20	1500			1200	900	700	550	—	—	—	—	—
		A	12	900			720	540	420	330	—	—	—	—	—
		B	6	450			360	270	210	160	—	—	—	—	—
		(Motor rotation speed)		(4500 rpm)			(3650 rpm)	(2700 rpm)	(2100 rpm)	(1650 rpm)	—	—	—	—	—
LEFS32	200 W equivalent	H	24	1500			1200	930	750	610	510	—	—	—	
		A	16	1000			800	620	500	410	340	—	—	—	
		B	8	500			400	310	250	200	170	—	—	—	
		(Motor rotation speed)		(3750 rpm)			(3000 rpm)	(2325 rpm)	(1875 rpm)	(1537 rpm)	(1275 rpm)	—	—	—	
LEFS40	400 W equivalent	H	30	—	1500			1410	1140	930	780	500	500	—	
		A	20	—	1000			940	760	620	520	440	380	—	
		B	10	—	500			470	380	310	260	220	190	—	
		(Motor rotation speed)		—	(3000 rpm)			(2820 rpm)	(2280 rpm)	(1860 rpm)	(1560 rpm)	(1320 rpm)	(1140 rpm)	—	

- LEFS
- LEFB
- LEJS
- LEJB
- LEL
- LEM
- LEJ
- LEYG
- LES
- LESH
- LEPY
- LEPS
- LER
- LEH
- LEH
- LEJ-X5
- LEJ-X5
- 11-LEFS
- 11-LEFS
- 11-LEJS
- 11-LEJS
- 25A-
- LEC
- LEC
- JXC
- JXC
- LECS
- LECS-T
- LECS
- LECS-T
- LECY
- LECY
- Motorless
- LAT3

Work Load–Acceleration/Deceleration Graph (Guide)

LEFS□25□H/Ball Screw Drive

Horizontal

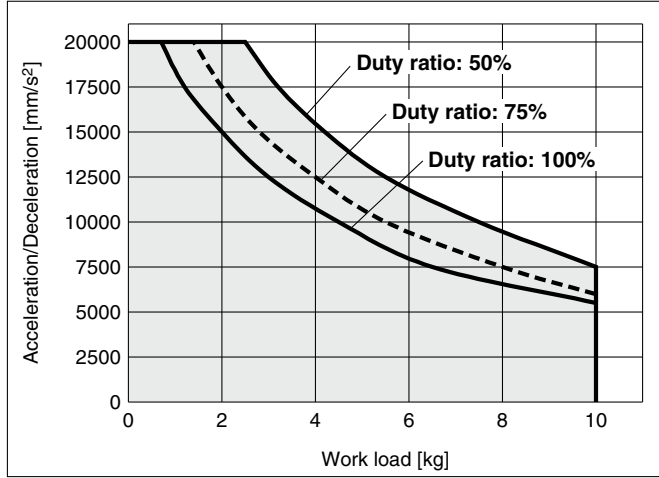

LEFS□25□H/Ball Screw Drive

Vertical

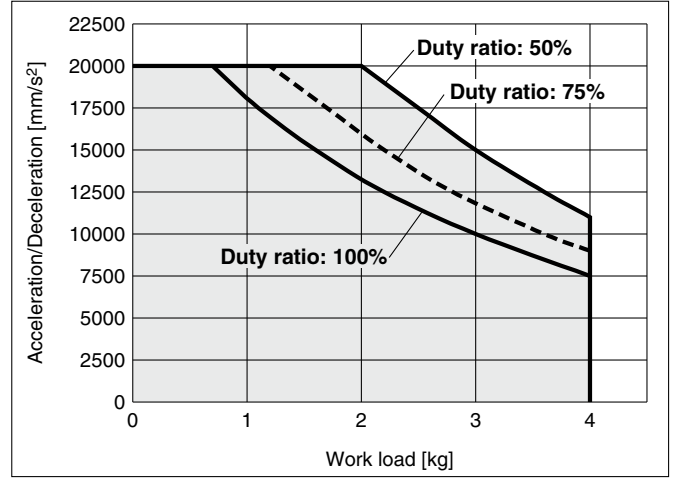

LEFS□25□A/Ball Screw Drive

Horizontal

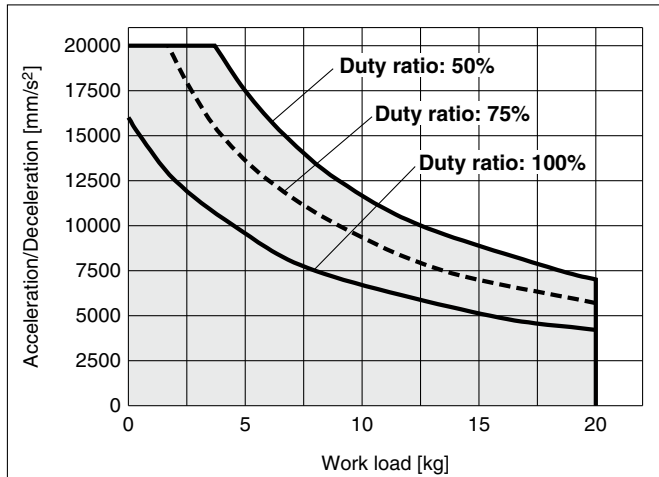

LEFS□25□A/Ball Screw Drive

Vertical

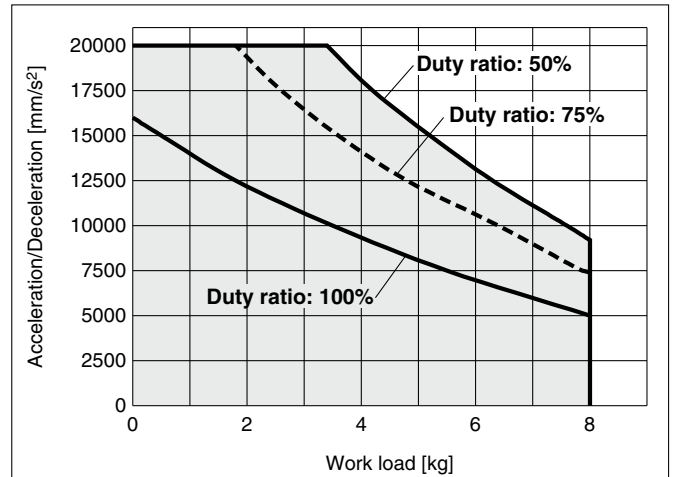

LEFS□25□B/Ball Screw Drive

Horizontal

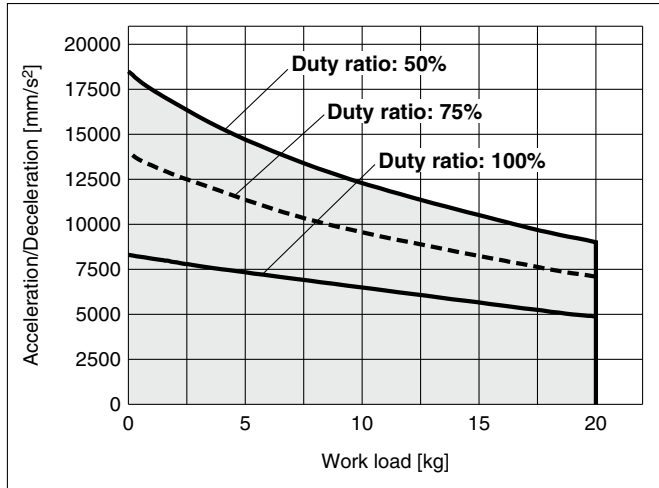

LEFS□25□B/Ball Screw Drive

Vertical

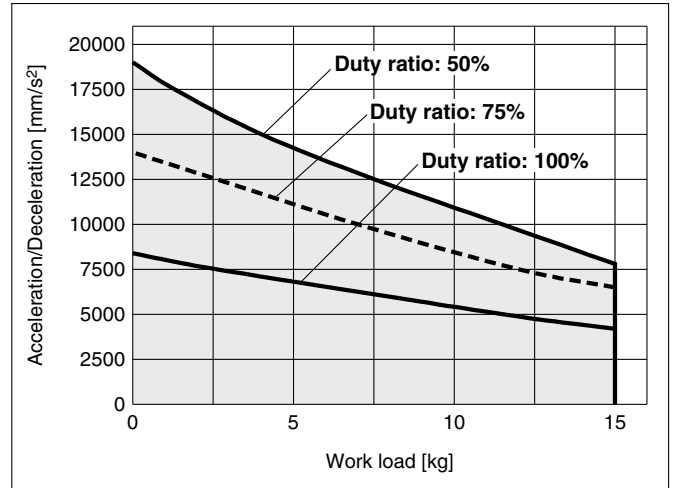

Work Load–Acceleration/Deceleration Graph (Guide)

LEFS□32□H/Ball Screw Drive

Horizontal

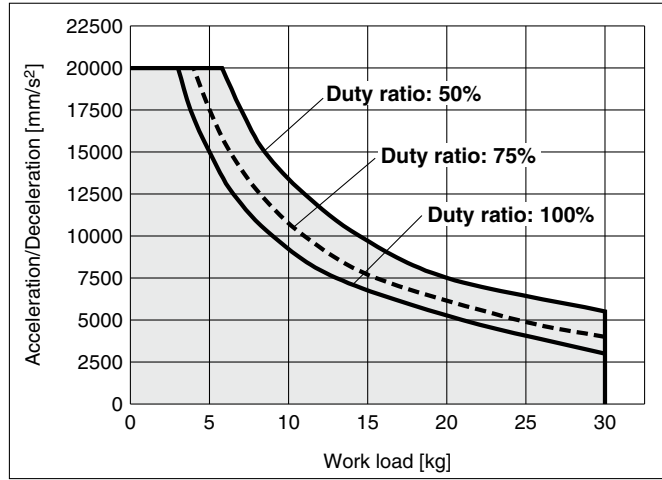

LEFS□32□H/Ball Screw Drive

Vertical

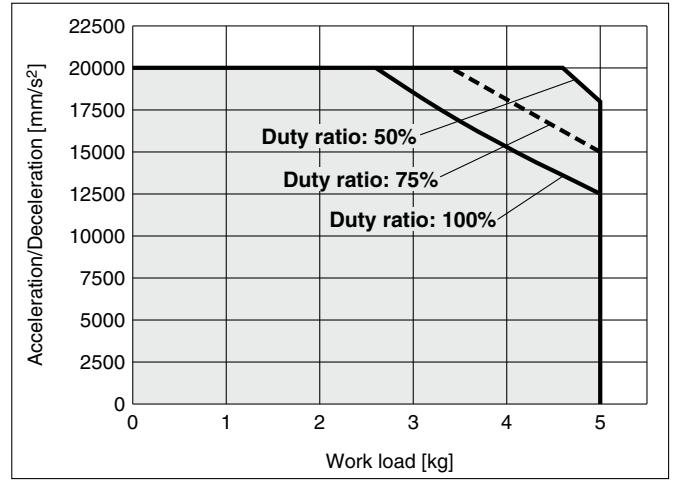

LEFS□32□A/Ball Screw Drive

Horizontal

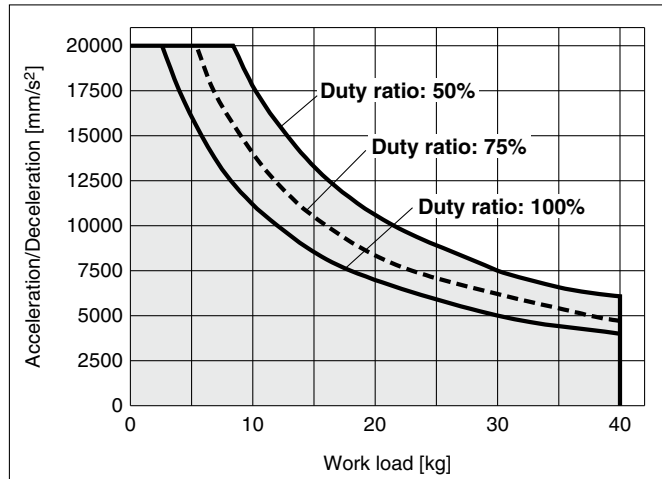

LEFS□32□A/Ball Screw Drive

Vertical

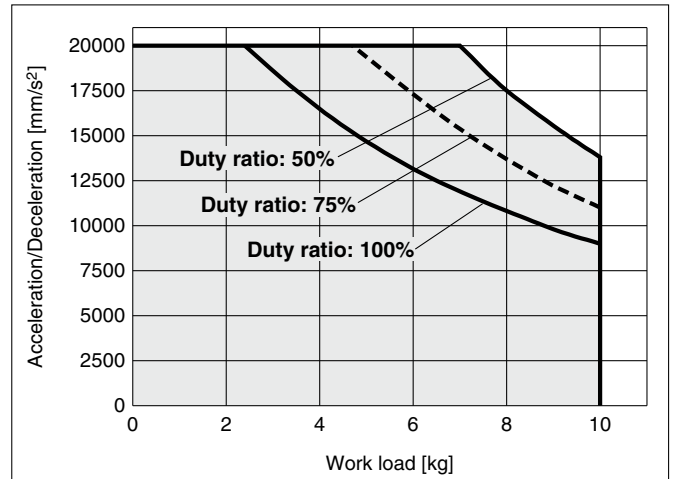

LEFS□32□B/Ball Screw Drive

Horizontal

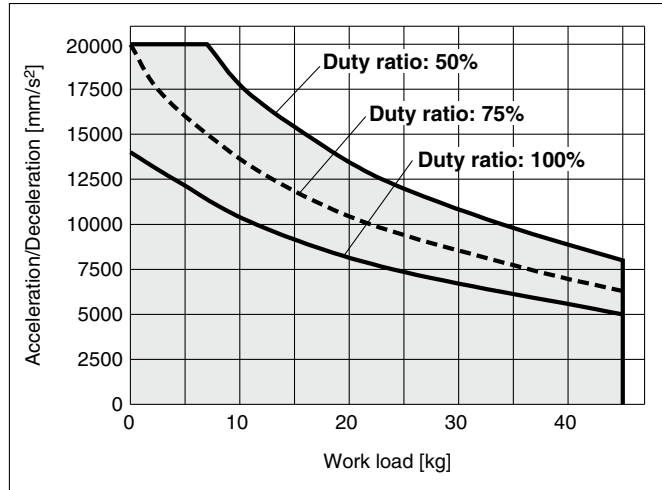

LEFS□32□B/Ball Screw Drive

Vertical

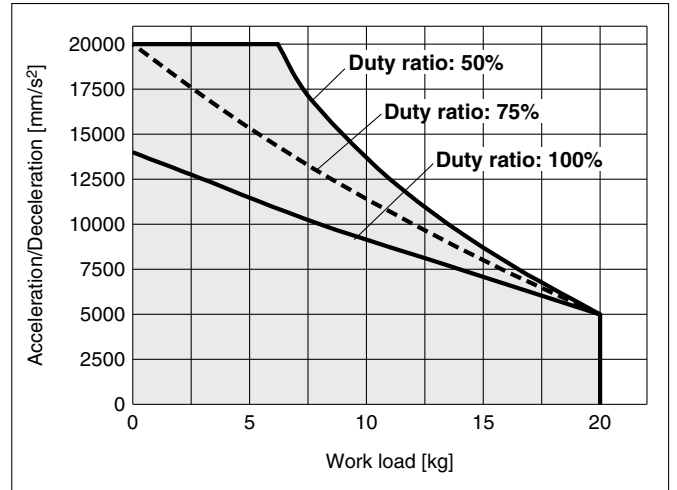

- LEFS
- LEFB
- LEJS
- LEJB
- LEL
- LEM
- LEY
- LEYG
- LES
- LESH
- LEPY
- LEPS
- LER
- LEH
- LEY-X5
- 11-LEFS
- 11-LEJS
- 25A-
- LEC□
- JXC□
- LECS□
- LECS□-T
- LECY□
- Motorless
- LAT3

Work Load–Acceleration/Deceleration Graph (Guide)

LEFS□40□H/Ball Screw Drive

Horizontal

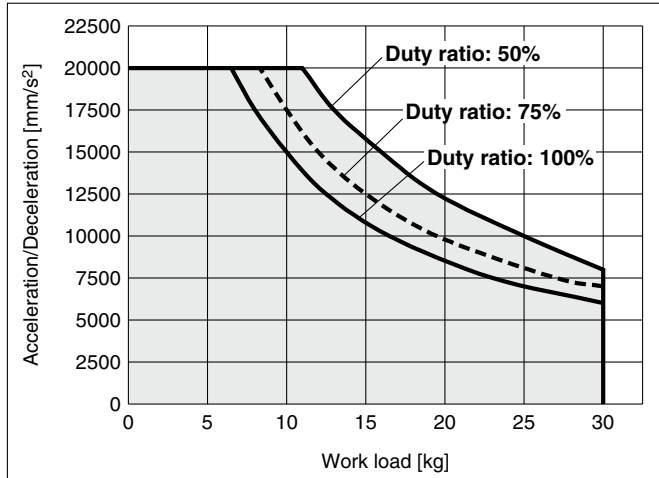

LEFS□40□H/Ball Screw Drive

Vertical

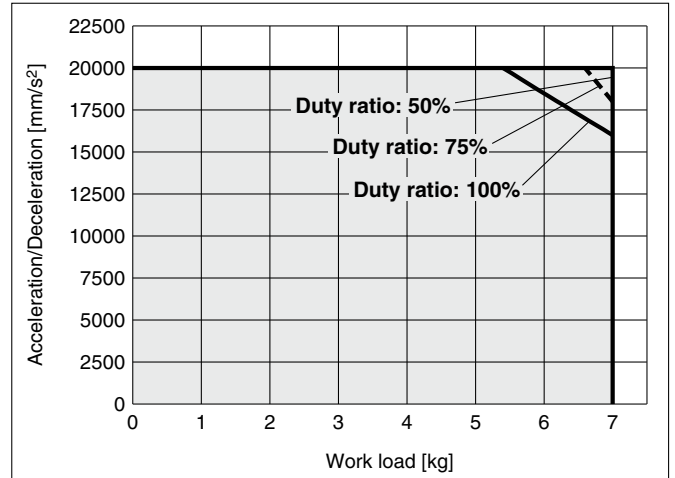

LEFS□40□A/Ball Screw Drive

Horizontal

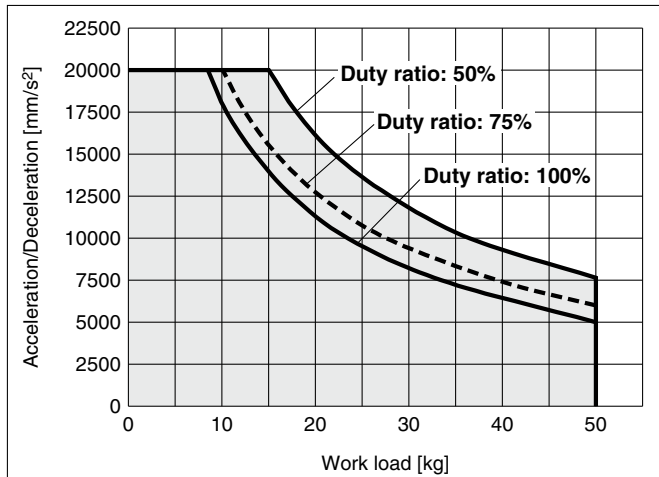

LEFS□40□A/Ball Screw Drive

Vertical

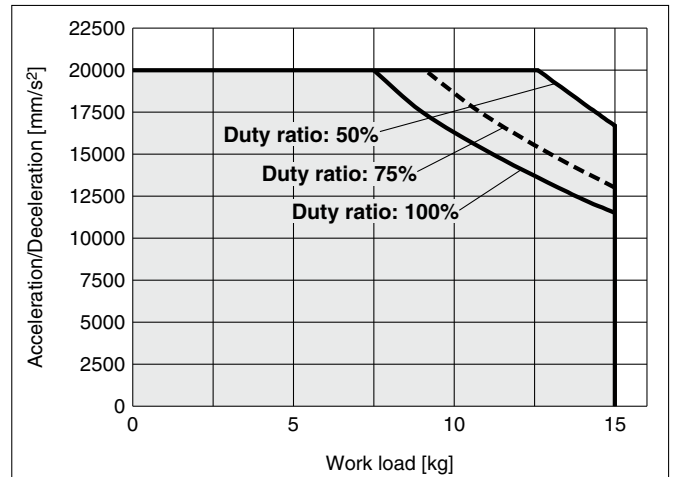

LEFS□40□B/Ball Screw Drive

Horizontal

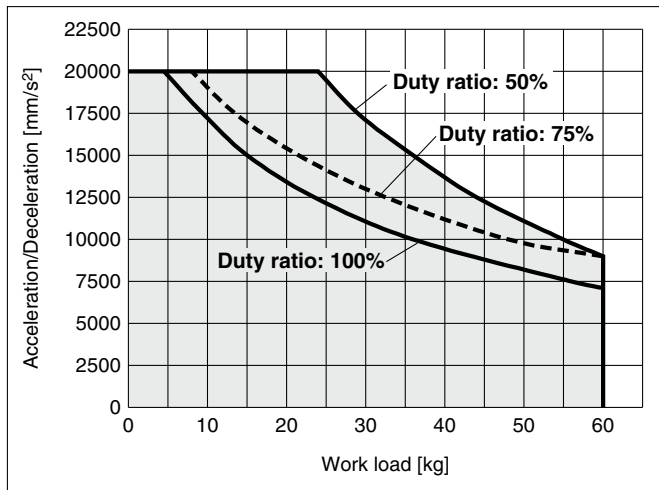

LEFS□40□B/Ball Screw Drive

Vertical

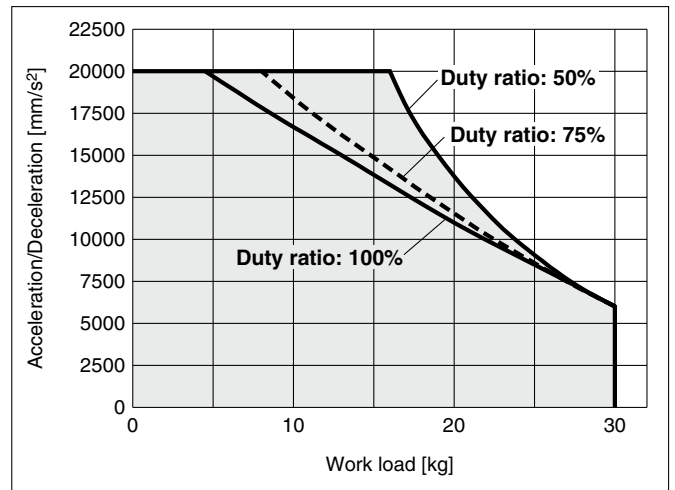

These graphs are examples of when the standard motor is mounted.
Determine the duty ratio after taking into account the load factor of the motor or driver to be used.

* This graph shows the amount of allowable overhang (guide unit) when the center of gravity of the workpiece overhangs in one direction. When selecting the overhang, refer to the "Calculation of Guide Load Factor" or the Electric Actuator Model Selection Software for confirmation: <https://www.smcworld.com>

Dynamic Allowable Moment

Acceleration/Deceleration ——— 1000 mm/s² - - - 3000 mm/s² ······ 5000 mm/s² - - - - 10000 mm/s² - - - - 20000 mm/s²

Orientation		Model		
Load overhanging direction m : Work load [kg] Me: Dynamic allowable moment [N·m] L : Overhang to the work load center of gravity [mm]		LEFS25□	LEFS32□	LEFS40□
Horizontal/Bottom	X 			
	Y 			
	Z 			
Wall	X 			
	Y 			
	Z 			

- LEFS
- LEFB
- LEJS
- LEJB
- LEL
- LEM
- LEY
- LEYG
- LES
- LESH
- LEPY
- LEPS
- LER
- LEH
- LEY-X5
- 11-LEFS
- 11-LEJS
- 25A-
- LEC□
- JXC□
- LECS□
- LECS□-T
- LECY□
- Motorless
- LAT3

* This graph shows the amount of allowable overhang (guide unit) when the center of gravity of the workpiece overhangs in one direction. When selecting the overhang, refer to the "Calculation of Guide Load Factor" or the Electric Actuator Model Selection Software for confirmation: <https://www.smcworld.com>

Dynamic Allowable Moment

Acceleration/Deceleration ——— 1000 mm/s² - - - 3000 mm/s² ······ 5000 mm/s² - - - - 10000 mm/s² - - - - 20000 mm/s²

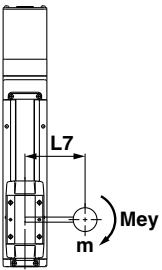
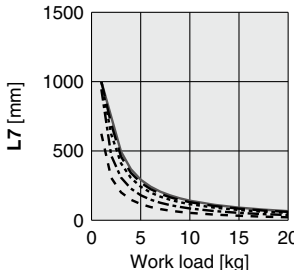
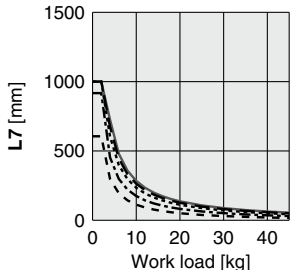
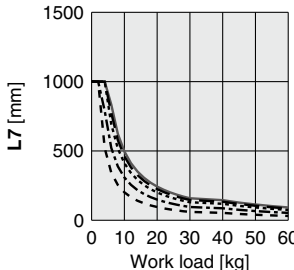
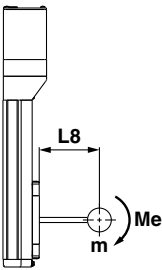
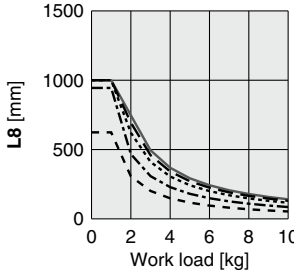
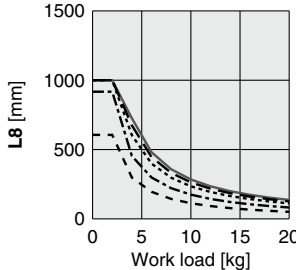
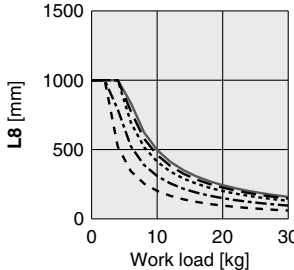
Orientation	Load overhanging direction m : Work load [kg] Me: Dynamic allowable moment [N·m] L : Overhang to the work load center of gravity [mm]	Model		
		LEFS25□	LEFS32□	LEFS40□
Vertical				
				

Calculation of Guide Load Factor

- Decide operating conditions.

Model: LEFS

Size: 25/32/40

Mounting orientation: Horizontal/Bottom/Wall/Vertical

Acceleration [mm/s²]: a

Work load [kg]: m

Work load center position [mm]: Xc/Yc/Zc

- Select the target graph while referencing the model, size, and mounting orientation.

- Based on the acceleration and work load, find the overhang [mm]: Lx/Ly/Lz from the graph.

- Calculate the load factor for each direction.

$$\alpha_x = X_c/L_x, \alpha_y = Y_c/L_y, \alpha_z = Z_c/L_z$$

- Confirm the total of α_x , α_y , and α_z is 1 or less.

$$\alpha_x + \alpha_y + \alpha_z \leq 1$$

When 1 is exceeded, consider a reduction of acceleration and work load, or a change of the work load center position and series.

Mounting Orientation

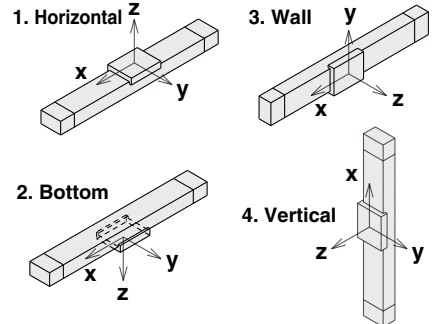

Example

- Operating conditions

Model: LEFS40

Size: 40

Mounting orientation: Horizontal

Acceleration [mm/s²]: 3000

Work load [kg]: 20

Work load center position [mm]: Xc = 0, Yc = 50, Zc = 200

- Select the graphs for horizontal of the LEFS40□ on page 824.

- Lx = 250 mm, Ly = 180 mm, Lz = 1000 mm

- The load factor for each direction can be found as follows.

$$\alpha_x = 0/250 = 0$$

$$\alpha_y = 50/180 = 0.27$$

$$\alpha_z = 200/1000 = 0.2$$

- $\alpha_x + \alpha_y + \alpha_z = 0.47 \leq 1$

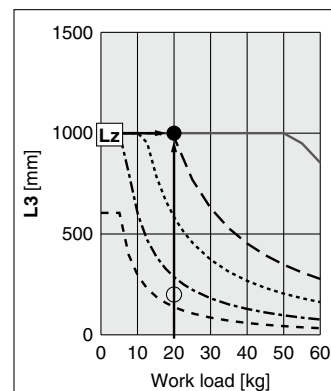
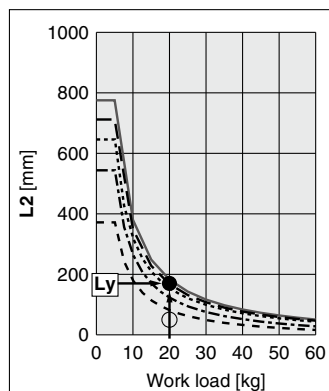
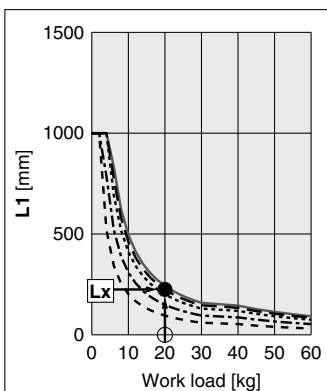
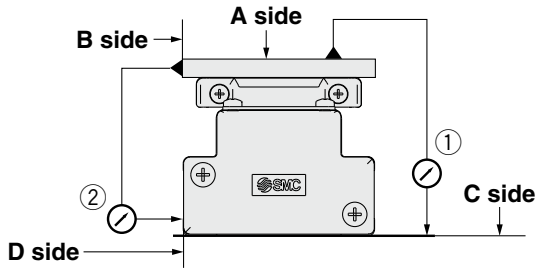

Table Accuracy (Reference Value)



Model	Traveling parallelism [mm] (Every 300 mm)	
	① C side traveling parallelism to A side	② D side traveling parallelism to B side
LEFS25	0.05	0.03
LEFS32	0.05	0.03
LEFS40	0.05	0.03

* Traveling parallelism does not include the mounting surface accuracy.

Table Displacement (Reference Value)

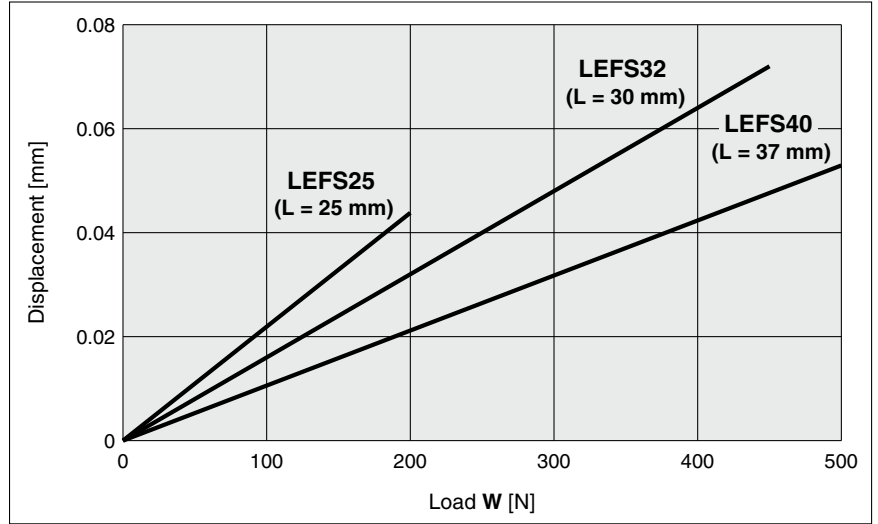
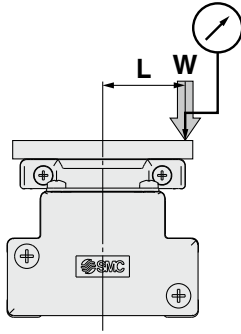

* This displacement is measured when a 15 mm aluminum plate is mounted and fixed on the table.
* Check the clearance and play of the guide separately.

Overhang Displacement Due to Table Clearance (Initial Reference Value)

Basic Type

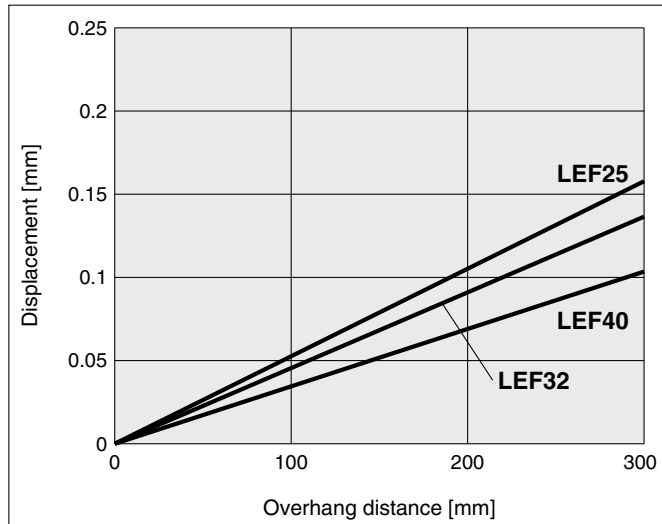

High-Precision Type

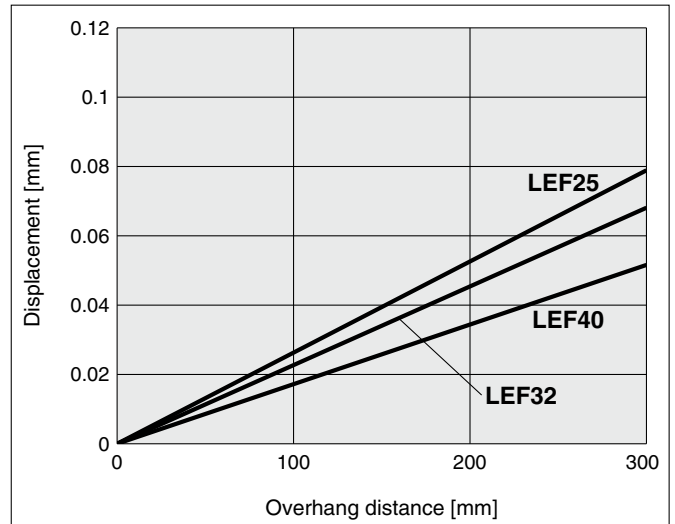

- LEFS
- LEFB
- LEJS
- LEJB
- LEL
- LEM
- LEY
- LEYG
- LES
- LESH
- LEPY
- LEPS
- LER
- LEH
- LEY-X5
- 11-LEFS
- 11-LEJS
- 11-LEJS
- 25A-
- LEC
- JXC
- LECS
- LECS-T
- LECY
- Motorless
- LAT3

Electric Actuator/Slider Type Ball Screw Drive

LEFS Series LEFS25, 32, 40

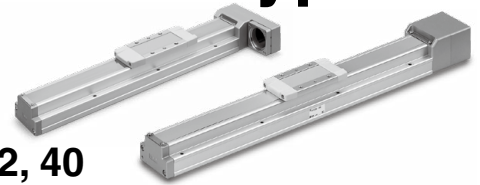

How to Order

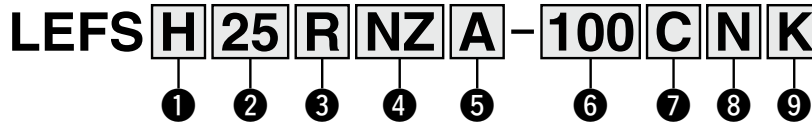

① Accuracy

Nil	Basic type
H	High-precision type

② Size

25
32
40

③ Motor mounting position

Nil	In-line
R	Right side parallel
L	Left side parallel

④ Motor type

Symbol	Type
NZ	Mounting type Z
NY	Mounting type Y
NX	Mounting type X
NW	Mounting type W
NV	Mounting type V
NU	Mounting type U
NT	Mounting type T
NM1	Mounting type M1
NM2	Mounting type M2
NM3	Mounting type M3

⑤ Lead [mm]

Symbol	LEFS25	LEFS32	LEFS40
H	20	24	30
A	12	16	20
B	6	8	10

⑥ Stroke [mm]

50	50
to	to
1200	1200

* Refer to the applicable stroke table.

⑧ Grease application (Seal band part)

Nil	With
N	Without (Roller specification)

⑦ Auto switch compatibility

Nil	None
C	With (Includes 1 mounting bracket)

* If 2 or more are required, please order them separately. (Part no.: LEF-D-2-1 For details, refer to page 868.)

* Order auto switches separately. (For details, refer to pages 869 to 871.)

* When "Nil" is selected, the product will not come with a built-in magnet for an auto switch, and so a mounting bracket cannot be secured. Be sure to select an appropriate model initially as the product cannot be changed to have auto switch compatibility after purchase.

⑨ Positioning pin hole

Nil	Housing B bottom*1	
K	Body bottom 2 locations	

*1 Refer to the body mounting example on page 873 for the mounting method.

●: Standard

Applicable Stroke Table

Model	Stroke [mm]	50	100	150	200	250	300	350	400	450	500	550	600	650	700	750	800	850	900	950	1000	1100	1200	
LEFS25		●	●	●	●	●	●	●	●	●	●	●	●	●	●	●	●	●	●	●	●	●	●	●
LEFS32		●	●	●	●	●	●	●	●	●	●	●	●	●	●	●	●	●	●	●	●	●	●	●
LEFS40		—	—	●	●	●	●	●	●	●	●	●	●	●	●	●	●	●	●	●	●	●	●	●

* Please consult with SMC for non-standard strokes as they are produced as special orders.

Compatible Motors

Applicable motor model			Size/Motor type																					
Manufacturer	Series	Type	25						32/40															
			NZ Mounting type Z	NY Mounting type Y	NX Mounting type X	NM1 Mounting type M1	NM2 Mounting type M2	NM3 Mounting type M3	NZ Mounting type Z	NY Mounting type Y	NX Mounting type X	NW Mounting type W	NV Mounting type V	NU Mounting type U	NT Mounting type T	NM1 Mounting type M1	NM2 Mounting type M2							
Mitsubishi Electric Corporation	MELSERVO-JN	HF-KN	●	—	—	—	—	—	—	—	●	—	—	—	—	—	—	—	—	—	—	—	—	—
	MELSERVO-J4	HG-KR	●	—	—	—	—	—	—	—	●	—	—	—	—	—	—	—	—	—	—	—	—	—
	MELSERVO-J5	HK-KT	●	—	—	—	—	—	—	—	—	●	—	—	—	—	—	—	—	—	—	—	—	—
YASKAWA Electric Corporation	Σ-V	SGMJV	●	—	—	—	—	—	—	—	●	—	—	—	—	—	—	—	—	—	—	—	—	—
	Σ-7	SGM7J/SGM7A	●	—	—	—	—	—	—	—	●	—	—	—	—	—	—	—	—	—	—	—	—	—
SANYO DENKI CO., LTD.	SANMOTION R	R2	●	—	—	—	—	—	—	—	●	—	—	—	—	—	—	—	—	—	—	—	—	—
	Sysmac G5	R88M-K	●	—	—	—	—	—	—	—	—	●	—	—	—	—	—	—	—	—	—	—	—	—
OMRON Corporation	1 S	R88M-1	●	—	—	—	—	—	—	—	—	●	—	—	—	—	—	—	—	—	—	—	—	—
	MINAS A5	MSM□/MHMD	—	●	—	—	—	—	—	—	—	—	●	—	—	—	—	—	—	—	—	—	—	—
Panasonic Corporation	MINAS A6	MSMF	—	●	—	—	—	—	—	—	—	—	●	—	—	—	—	—	—	—	—	—	—	—
		MHMF	●	—	—	—	—	—	—	—	—	—	—	●	—	—	—	—	—	—	—	—	—	—
FANUC CORPORATION	βis (-B)	β	●	—	—	—	—	—	—	—	—	—	—	—	—	—	●	—	—	—	—	—	—	—
NIDEC SANKYO CORPORATION	S-FLAG	MA/MH/MM	●	—	—	—	—	—	—	—	—	—	—	—	—	—	—	—	—	—	—	—	—	—
KEYENCE CORPORATION	SV	SV-M/SV-B	●	—	—	—	—	—	—	—	—	—	—	—	—	—	—	—	—	—	—	—	—	—
	SV2	SV2-M/SV2-B	●	—	—	—	—	—	—	—	—	—	—	—	—	—	—	—	—	—	—	—	—	—
FUJI ELECTRIC CO., LTD.	ALPHA5	GYS/GYB	●	—	—	—	—	—	—	—	—	—	—	—	—	—	—	—	—	—	—	—	—	—
	ALPHA7	GYS/GYB	●	—	—	—	—	—	—	—	—	—	—	—	—	—	—	—	—	—	—	—	—	—
	FALDIC α	GYS	●	—	—	—	—	—	—	—	—	—	—	—	—	—	—	—	—	—	—	—	—	—
MinebeaMitsumi Inc.	SZ	A17PM/A23KM	—	—	—	—	—	—	—	—	—	—	—	—	—	—	—	—	—	—	—	—	—	—
Shinano Kenshi Co., Ltd.	CSB-BZ	CSB-BZ	—	—	—	—	—	—	—	—	—	—	—	—	—	—	—	—	—	—	—	—	—	—
ORIENTAL MOTOR Co., Ltd.	AR/AZ	AR/AZ (46 only)	—	—	—	—	—	—	—	—	—	—	—	—	—	—	—	—	—	—	—	—	—	—
	AR/AZ	AR/AZ	—	—	—	—	—	—	—	—	—	—	—	—	—	—	—	—	—	—	—	—	—	—
FASTECH Co., Ltd.	Ezi-SERVO	EzM	—	—	—	—	—	—	—	—	—	—	—	—	—	—	—	—	—	—	—	—	—	—
Rockwell Automation, Inc. (Allen-Bradley)	MP-/VP-	MP/VP	—	—	—	—	—	—	—	—	—	—	—	—	—	—	—	—	—	—	—	—	—	—
	TL	TLY-A	●	—	—	—	—	—	—	—	—	—	—	—	—	—	—	—	—	—	—	—	—	—
Beckhoff Automation GmbH	AM	AM30	●	—	—	—	—	—	—	—	—	—	—	—	—	—	—	—	—	—	—	—	—	—
	AM	AM31	●	—	—	—	—	—	—	—	—	—	—	—	—	—	—	—	—	—	—	—	—	—
	AM	AM80/AM81	●	—	—	—	—	—	—	—	—	—	—	—	—	—	—	—	—	—	—	—	—	—
Siemens AG	1FK7	1FK7	—	—	—	—	—	—	—	—	—	—	—	—	—	—	—	—	—	—	—	—	—	—
Delta Electronics, Inc.	ASDA-A2	ECMA	●	—	—	—	—	—	—	—	—	—	—	—	—	—	—	—	—	—	—	—	—	—
ANCA Motion	AMD2000	Alpha	●	—	—	—	—	—	—	—	—	—	—	—	—	—	—	—	—	—	—	—	—	—

*1 Motor mounting position: In-line only *2 Only size 32 is available when the motor mounting position is right (or left) side parallel. *3 Motor mounting position: Right (or left) side parallel only

Specifications*2

- Values in this specifications table are the allowable values of the actuator body with the standard motor mounted.
- Do not use the actuator so that it exceeds these values.

Model		LEFS25			LEFS32			LEFS40				
Actuator specifications	Stroke [mm]*1	50 to 800			50 to 1000			150 to 1200				
	Work load [kg]	Horizontal	10	20	20	30	40	45	30	50	60	
		Vertical	4	8	15	5	10	20	7	15	30	
	Speed [mm/s]	Stroke range	Up to 400	1500	900	450	1500	1000	500	1500	1000	500
			401 to 500	1200	720	360	1500	1000	500	1500	1000	500
			501 to 600	900	540	270	1200	800	400	1500	1000	500
			601 to 700	700	420	210	930	620	310	1410	940	470
			701 to 800	550	330	160	750	500	250	1140	760	380
			801 to 900	—	—	—	610	410	200	930	620	310
			901 to 1000	—	—	—	510	340	170	780	520	260
			1001 to 1100	—	—	—	—	—	—	500	440	220
	1101 to 1200	—	—	—	—	—	—	500	380	190		
	Pushing return to origin speed [mm/s]		30 or less									
	Positioning repeatability [mm]	Basic type	±0.02									
		High-precision type	±0.01									
	Lost motion*3 [mm]	Basic type	0.1 or less									
		High-precision type	0.05 or less									
	Ball screw specifications	Thread size [mm]	ø10			ø12			ø15			
Lead [mm]		20	12	6	24	16	8	30	20	10		
Shaft length [mm]		Stroke + 150			Stroke + 185			Stroke + 235				
Max. acceleration/deceleration [mm/s ²]		20000*4										
Impact/Vibration resistance [m/s ²]*6		50/20										
Actuation type		Ball screw (LEFS□), Ball screw + Belt (LEFS□ ^R)										
Guide type		Linear guide										
Operating temperature range [°C]		5 to 40										
Operating humidity range [%RH]		90 or less (No condensation)										
Other specifications*5	Actuation unit weight [kg]	0.2			0.3			0.55				
	Other inertia [kg-cm ²]	0.02 (LEFS25)			0.08 (LEFS32)			0.08 (LEFS40)				
		0.02 (LEFS25 ^R)			0.06 (LEFS32 ^R)			0.17 (LEFS40 ^R)				
	Friction coefficient	0.05										
Mechanical efficiency	0.8											
Reference motor specifications*7	Motor shape	□40			□60							
	Motor type	AC servo motor (100 V/200 V)										
	Rated output capacity [W]	100			200			400				
	Rated torque [N·m]	0.32			0.64			1.3				

- *1 Please consult with SMC for non-standard strokes as they are produced as special orders.
 *2 Do not allow collisions at either end of the table traveling distance at a speed exceeding "pushing return to origin speed." Additionally, when running the positioning operation, do not set within 2 mm of both ends.
 *3 A reference value for correcting an error in reciprocal operation
 *4 Maximum acceleration/deceleration changes according to the work load.
 Refer to the "Work Load-Acceleration/Deceleration Graph (Guide)" for ball screw drive on pages 821 to 823.
 *5 Each value is only to be used as a guide to select a motor of the appropriate capacity.
 *6 Impact resistance: No malfunction occurred when the actuator was tested with a drop tester in both an axial direction and a perpendicular direction to the lead screw. (The test was performed with the actuator in the initial state.)
 Vibration resistance: No malfunction occurred in a test ranging between 45 to 2000 Hz. The test was performed in both an axial direction and a perpendicular direction to the lead screw. (The test was performed with the actuator in the initial state.)
 *7 For other specifications, refer to the specifications of the motor that is to be installed.

Weight

Model	LEFS25															
Stroke [mm]	50	100	150	200	250	300	350	400	450	500	550	600	650	700	750	800
Product weight [kg]	1.50	1.70	1.80	2.00	2.10	2.25	2.40	2.55	2.70	2.80	2.90	3.10	3.35	3.50	3.65	3.80

Model	LEFS32																			
Stroke [mm]	50	100	150	200	250	300	350	400	450	500	550	600	650	700	750	800	850	900	950	1000
Product weight [kg]	2.40	2.60	2.80	3.00	3.20	3.40	3.60	3.80	4.00	4.20	4.40	4.60	4.80	5.00	5.20	5.40	5.60	5.80	6.00	6.20

Model	LEFS40																			
Stroke [mm]	150	200	250	300	350	400	450	500	550	600	650	700	750	800	850	900	950	1000	1100	1200
Product weight [kg]	4.60	4.80	5.20	5.35	5.70	5.95	6.30	6.50	6.80	6.95	7.40	7.60	8.00	8.15	8.50	8.75	9.10	9.30	9.76	10.32



LEFS Series

Motorless Type

Refer to the "Motor Mounting" on page 841 for details about motor mounting and included parts.

Dimensions: Ball Screw Drive

LEFS25

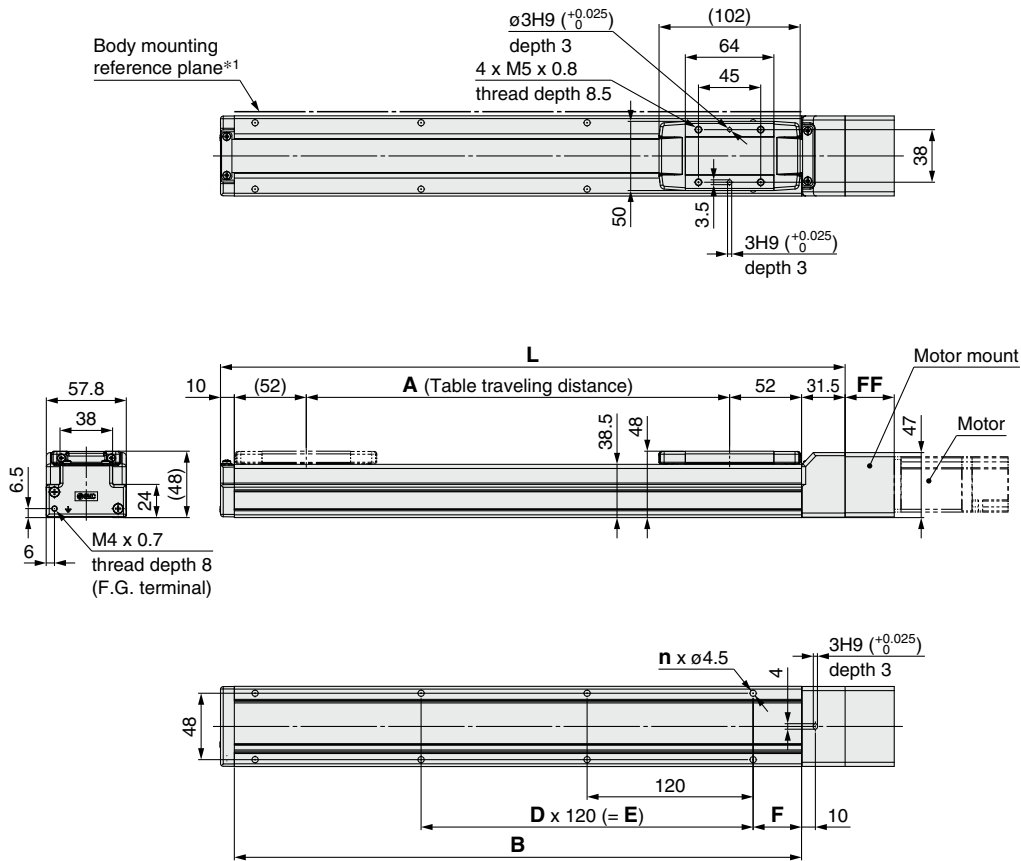

Motor type: NZ, NY, NX

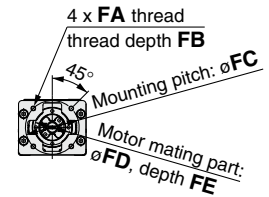

Motor type: NM1, NM2

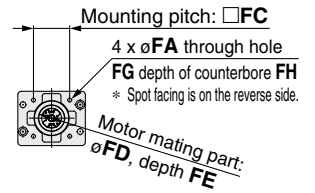

*1 When mounting the actuator using the body mounting reference plane, set the height of the opposite surface or pin to be 3 mm or more. (Recommended height 5 mm)

Dimensions

Stroke	L	A	B	n	D	E	F
50	201.5	56	160	4	—	—	20
100	251.5	106	210	4	—	—	35
150	301.5	156	260	4	—	—	35
200	351.5	206	310	6	2	240	35
250	401.5	256	360	6	2	240	35
300	451.5	306	410	8	3	360	35
350	501.5	356	460	8	3	360	35
400	551.5	406	510	8	3	360	35
450	601.5	456	560	10	4	480	35
500	651.5	506	610	10	4	480	35
550	701.5	556	660	12	5	600	35
600	751.5	606	710	12	5	600	35
650	801.5	656	760	12	5	600	35
700	851.5	706	810	14	6	720	35
750	901.5	756	860	14	6	720	35
800	951.5	806	910	16	7	840	35

Motor Mounting Dimensions

Motor type	FA	FB	FC	FD	FE	FF	FG	FH
NZ/NX	M4 x 0.7	8	46	30	3.5	35.5	—	—
NY	M3 x 0.5	8	45	30	3.5	35.5	—	—
NM1	3.4	—	31	22*1	2.5*1	24	6.5	13.5
NM2	3.4	—	31	22*1	2.5*1	33.1	6.5	22.6

*1 Dimensions after mounting a ring spacer (Refer to page 841.)

Refer to the "Motor Mounting" on page 841 for details about motor mounting and included parts.

Dimensions: Ball Screw Drive

LEFS25

Positioning pin hole*1 (Option): Body bottom

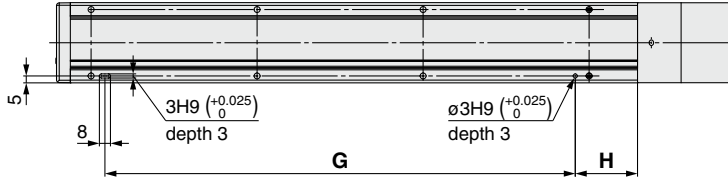

*1 When using the body bottom positioning pin holes, do not simultaneously use the housing B bottom pin hole.

With auto switch (Option)

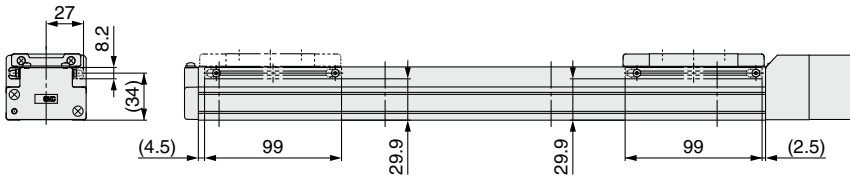

* For strokes of 99 mm or less, only 2 auto switch mounting brackets can be installed on the motor side.

Dimensions [mm]

Stroke	G	H
50	100	30
100	100	45
150	100	45
200	220	45
250	220	45
300	340	45
350	340	45
400	340	45
450	460	45
500	460	45
550	580	45
600	580	45
650	580	45
700	700	45
750	700	45
800	820	45

LEFS
LEFB

LEJS
LEJB

LEL

LEM

LEY
LEYG

LES
LESH

LEPY
LEPS

LER

LEH

LEY-X5

11-LEFS

11-LEJS

25A-

LEC

JXC

LECS
LECS-T

LECY

Motorless

LAT3

LEFS Series

Motorless Type

Refer to the "Motor Mounting" on page 841 for details about motor mounting and included parts.

Dimensions: Ball Screw Drive

LEFS32

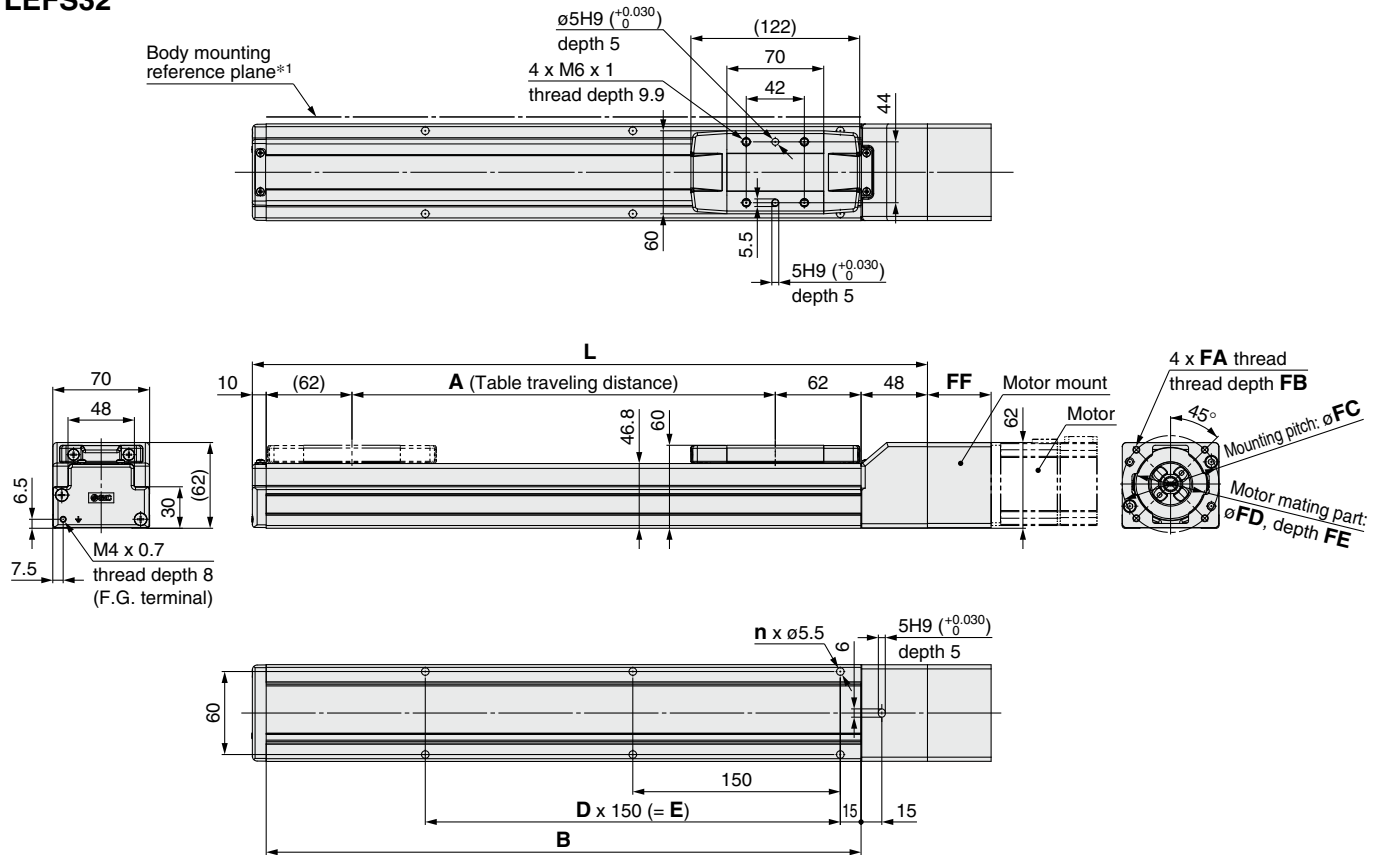

*1 When mounting the actuator using the body mounting reference plane, set the height of the opposite surface or pin to be 3 mm or more. (Recommended height 5 mm)

Dimensions

[mm]

Stroke	L	A	B	n	D	E
50	238	56	180	4	—	—
100	288	106	230	4	—	—
150	338	156	280	4	—	—
200	388	206	330	6	2	300
250	438	256	380	6	2	300
300	488	306	430	6	2	300
350	538	356	480	8	3	450
400	588	406	530	8	3	450
450	638	456	580	8	3	450
500	688	506	630	10	4	600
550	738	556	680	10	4	600
600	788	606	730	10	4	600
650	838	656	780	12	5	750
700	888	706	830	12	5	750
750	938	756	880	12	5	750
800	988	806	930	14	6	900
850	1038	856	980	14	6	900
900	1088	906	1030	14	6	900
950	1138	956	1080	16	7	1050
1000	1188	1006	1130	16	7	1050

Motor Mounting Dimensions

[mm]

Motor type	FA	FB	FC	FD	FE	FF
NZ/NT	M5 x 0.8	9	70	50	5	46
NY	M4 x 0.7	8	70	50	5	46
NX	M5 x 0.8	9	63	40*1	4.5*1	49.7
NW/NU	M5 x 0.8	9	70	50	5	47.5
NV	M4 x 0.7	8	63	40*1	4.5*1	49.7
NM1	M4 x 0.7	8	□47.14	38.1*1	4.5*1	21
NM2	M4 x 0.7	8	□50	36*1	4.5*1	40.1

*1 Dimensions after mounting a ring spacer (Refer to page 841.)

Refer to the "Motor Mounting" on page 841 for details about motor mounting and included parts.

Dimensions: Ball Screw Drive

LEFS32

Positioning pin hole*1 (Option): Body bottom

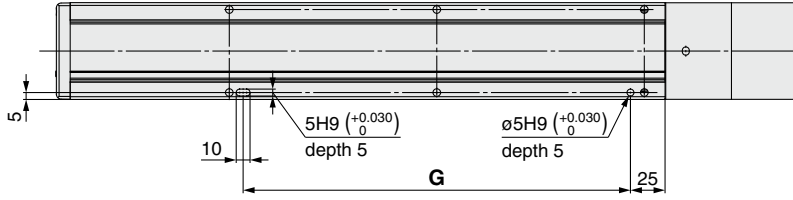

*1 When using the body bottom positioning pin holes, do not simultaneously use the housing B bottom pin hole.

With auto switch (Option)

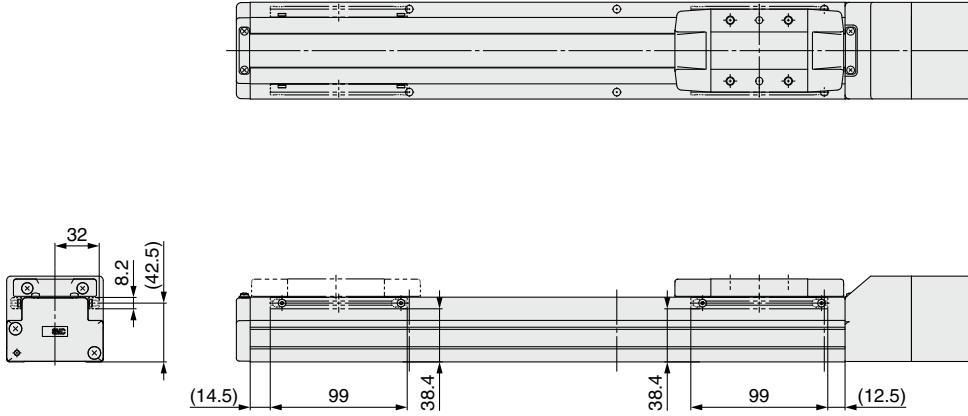

* For strokes of 99 mm or less, only 2 auto switch mounting brackets can be installed on the motor side.

Dimensions [mm]

Stroke	G
50	130
100	130
150	130
200	280
250	280
300	280
350	430
400	430
450	430
500	580
550	580
600	580
650	730
700	730
750	730
800	880
850	880
900	880
950	1030
1000	1030

LEFS
LEFB

LEJS
LEJB

LEL

LEM

LEY
LEYG

LES
LESH

LEPY
LEPS

LER

LEH

LEY-X5

11-LEFS

11-LEJS

25A-

LEC

JXC

LECS
LECS-T

LECY

Motorless

LAT3

Refer to the "Motor Mounting" on page 841 for details about motor mounting and included parts.

Dimensions: Ball Screw Drive

LEFS40

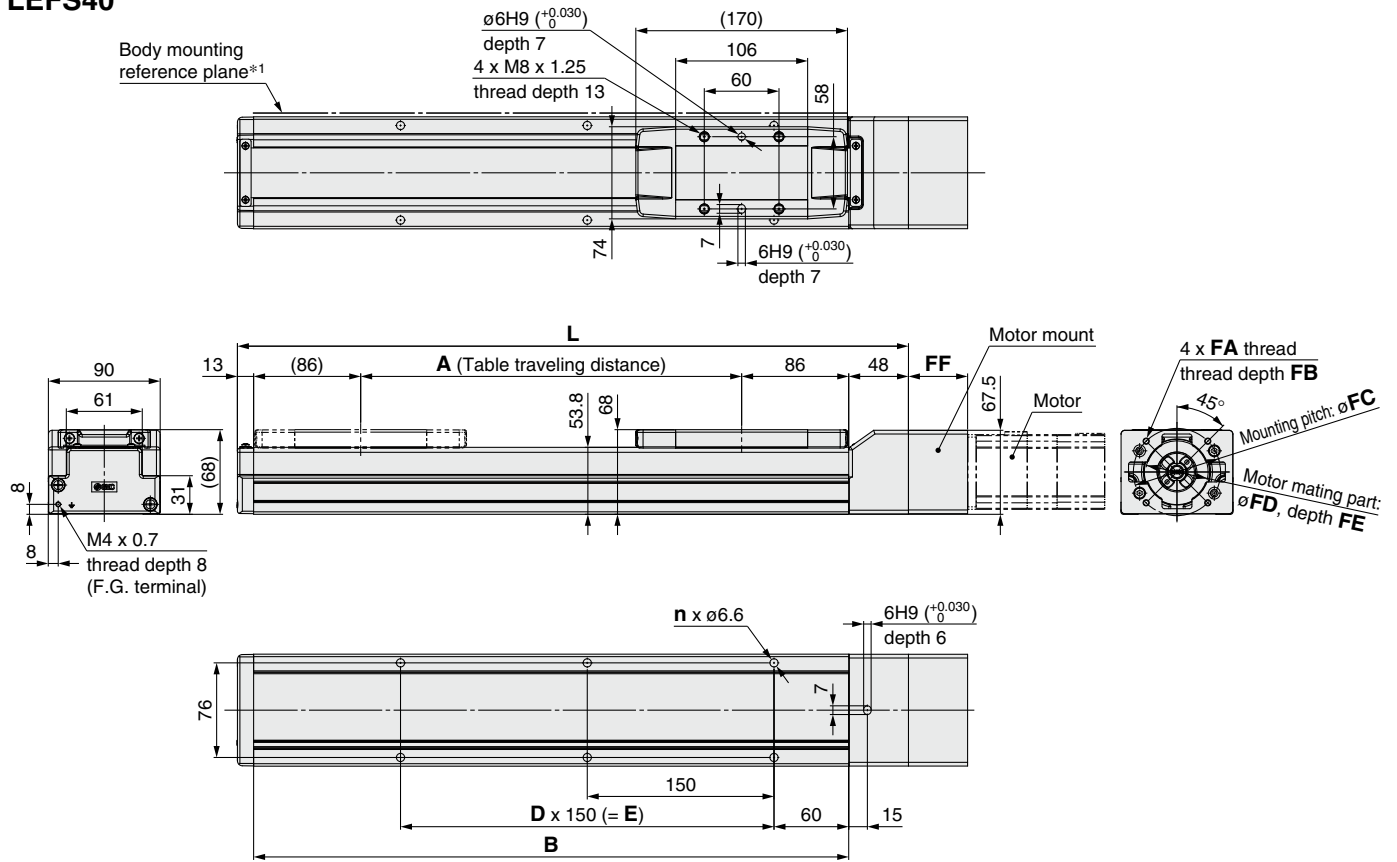

*1 When mounting the actuator using the body mounting reference plane, set the height of the opposite surface or pin to be 3 mm or more. (Recommended height 5 mm)

Dimensions [mm]

Stroke	L	A	B	n	D	E
150	389	156	328	4	—	150
200	439	206	378	6	2	300
250	489	256	428	6	2	300
300	539	306	478	6	2	300
350	589	356	528	8	3	450
400	639	406	578	8	3	450
450	689	456	628	8	3	450
500	739	506	678	10	4	600
550	789	556	728	10	4	600
600	839	606	778	10	4	600
650	889	656	828	12	5	750
700	939	706	878	12	5	750
750	989	756	928	12	5	750
800	1039	806	978	14	6	900
850	1089	856	1028	14	6	900
900	1139	906	1078	14	6	900
950	1189	956	1128	16	7	1050
1000	1239	1006	1178	16	7	1050
1100	1339	1106	1278	18	8	1200
1200	1439	1206	1378	18	8	1200

Motor Mounting Dimensions [mm]

Motor type	FA	FB	FC	FD	FE	FF
NZ/NT	M5 x 0.8	9	70	50	5	47.5
NY	M4 x 0.7	8	70	50	5	47.5
NX	M5 x 0.8	9	63	40*1	4.5*1	51
NW/NU	M5 x 0.8	9	70	50	5	48.8
NV	M4 x 0.7	8	63	40*1	4.5*1	51
NM1	M4 x 0.7	8	□47.14	38.1*1	4.5*1	22
NM2	M4 x 0.7	8	□50	36*1	4.5*1	41.4

*1 Dimensions after mounting a ring spacer (Refer to page 841.)

Refer to the "Motor Mounting" on page 841 for details about motor mounting and included parts.

Dimensions: Ball Screw Drive

LEFS40

Positioning pin hole*1 (Option): Body bottom

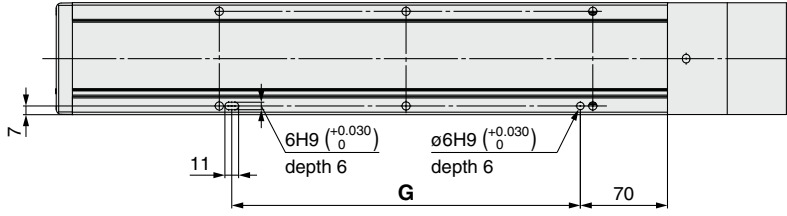

*1 When using the body bottom positioning pin holes, do not simultaneously use the housing B bottom pin hole.

With auto switch (Option)

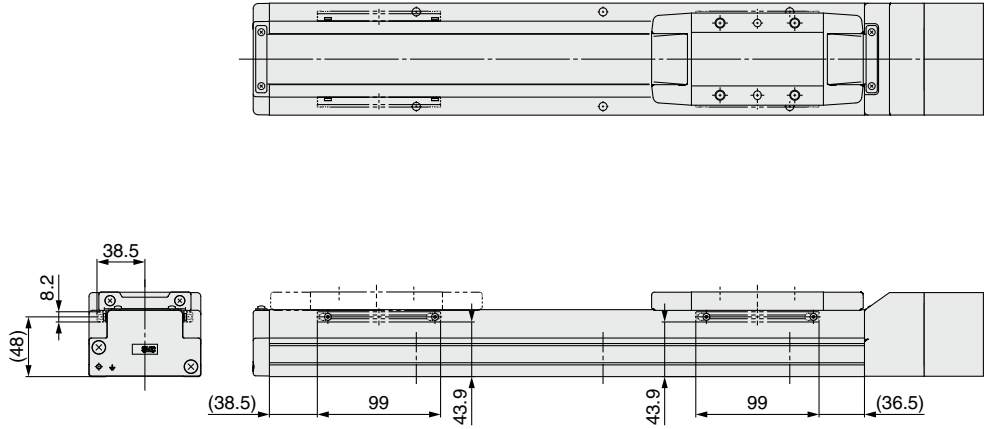

Dimensions [mm]

Stroke	G
150	130
200	280
250	280
300	280
350	430
400	430
450	430
500	580
550	580
600	580
650	730
700	730
750	730
800	880
850	880
900	880
950	1030
1000	1030
1100	1180
1200	1180

LEFS
LEFB

LEJS
LEJB

LEL

LEM

LEY
LEYG

LES
LESH

LEPY
LEPS

LER

LEH

LEY-X5

11-LEFS

11-LEJS

25A-

LEC

JXC

LECS
LECS-T

LECY

Motorless

LAT3

LEFS Series

Motorless Type

Refer to the "Motor Mounting" on page 842 for details about motor mounting and included parts.

Dimensions: Ball Screw Drive

LEFS25R

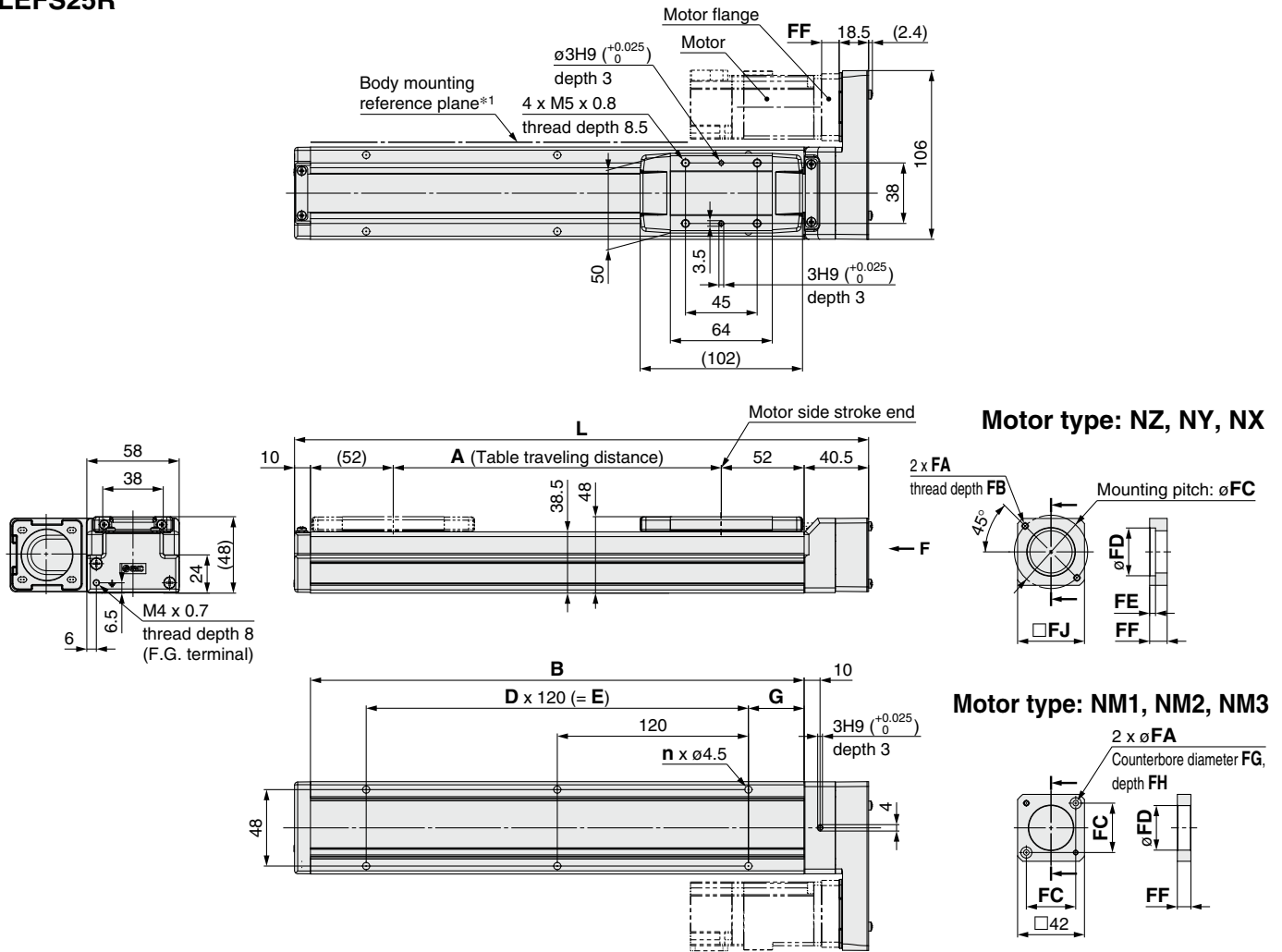

*1 When mounting the actuator using the body mounting reference plane, set the height of the opposite surface or pin to be 3 mm or more. (Recommended height 5 mm)

Dimensions

[mm]

Stroke	L	A	B	n	D	E	G
50	210.5	56	160	4	—	—	20
100	260.5	106	210	4	—	—	35
150	310.5	156	260	4	—	—	35
200	360.5	206	310	6	2	240	35
250	410.5	256	360	6	2	240	35
300	460.5	306	410	8	3	360	35
350	510.5	356	460	8	3	360	35
400	560.5	406	510	8	3	360	35
450	610.5	456	560	10	4	480	35
500	660.5	506	610	10	4	480	35
550	710.5	556	660	12	5	600	35
600	760.5	606	710	12	5	600	35
650	810.5	656	760	12	5	600	35
700	860.5	706	810	14	6	720	35
750	910.5	756	860	14	6	720	35
800	960.5	806	910	16	7	840	35

Motor Mounting Dimensions

[mm]

Motor type	FA	FB	FC	FD	FE	FF	FG	FH	FJ
NZ	M4 x 0.7	7.5	46	30	3.7	11	—	—	42
NY	M3 x 0.5	5.5	45	30	5	11	—	—	38
NX	M4 x 0.7	7	46	30	3.7	8	—	—	42
NM1/NM2	ø3.4	—	31	28	—	8.5	7	3.5	42
NM3	ø3.4	—	31	28	—	5.5	7	3.5	42

Refer to the "Motor Mounting" on page 842 for details about motor mounting and included parts.

Dimensions: Ball Screw Drive

LEFS25R

Positioning pin hole*1 (Option): Body bottom

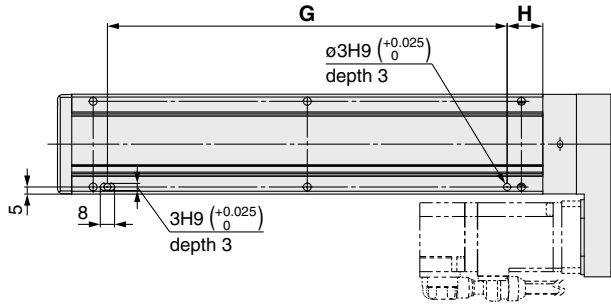

*1 When using the body bottom positioning pin holes, do not simultaneously use the housing B bottom pin hole.

With auto switch (Option)

LEFS25R

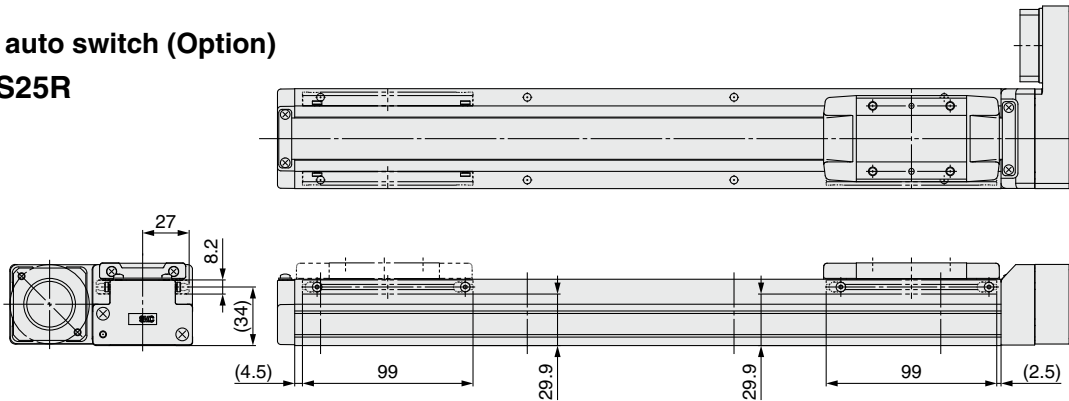

LEFS25L

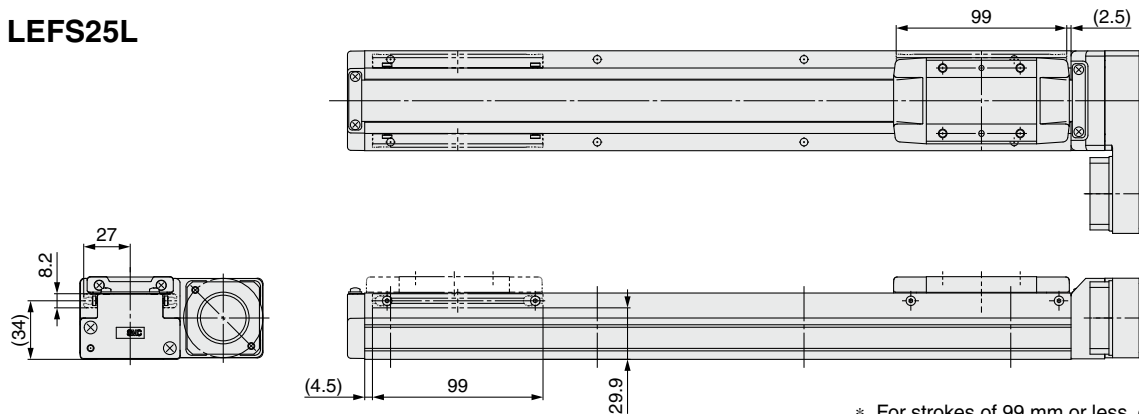

Dimensions [mm]

Stroke	G	H
50	100	30
100	100	45
150	100	45
200	220	45
250	220	45
300	340	45
350	340	45
400	340	45
450	460	45
500	460	45
550	580	45
600	580	45
650	580	45
700	700	45
750	700	45
800	820	45

* For strokes of 99 mm or less, only 1 auto switch mounting bracket can be installed on the motor side.

- LEFS
- LEFB
- LEJS
- LEJB
- LEL
- LEM
- LEY
- LEYG
- LES
- LESH
- LEPY
- LEPS
- LER
- LEH
- LEY-X5
- 11-LEFS
- 11-LEJS
- 25A-
- LEC
- JXC
- LECS
- LECS-T
- LECY
- Motorless
- LAT3

LEFS Series

Motorless Type

Refer to the "Motor Mounting" on page 842 for details about motor mounting and included parts.

Dimensions: Ball Screw Drive

LEFS32R

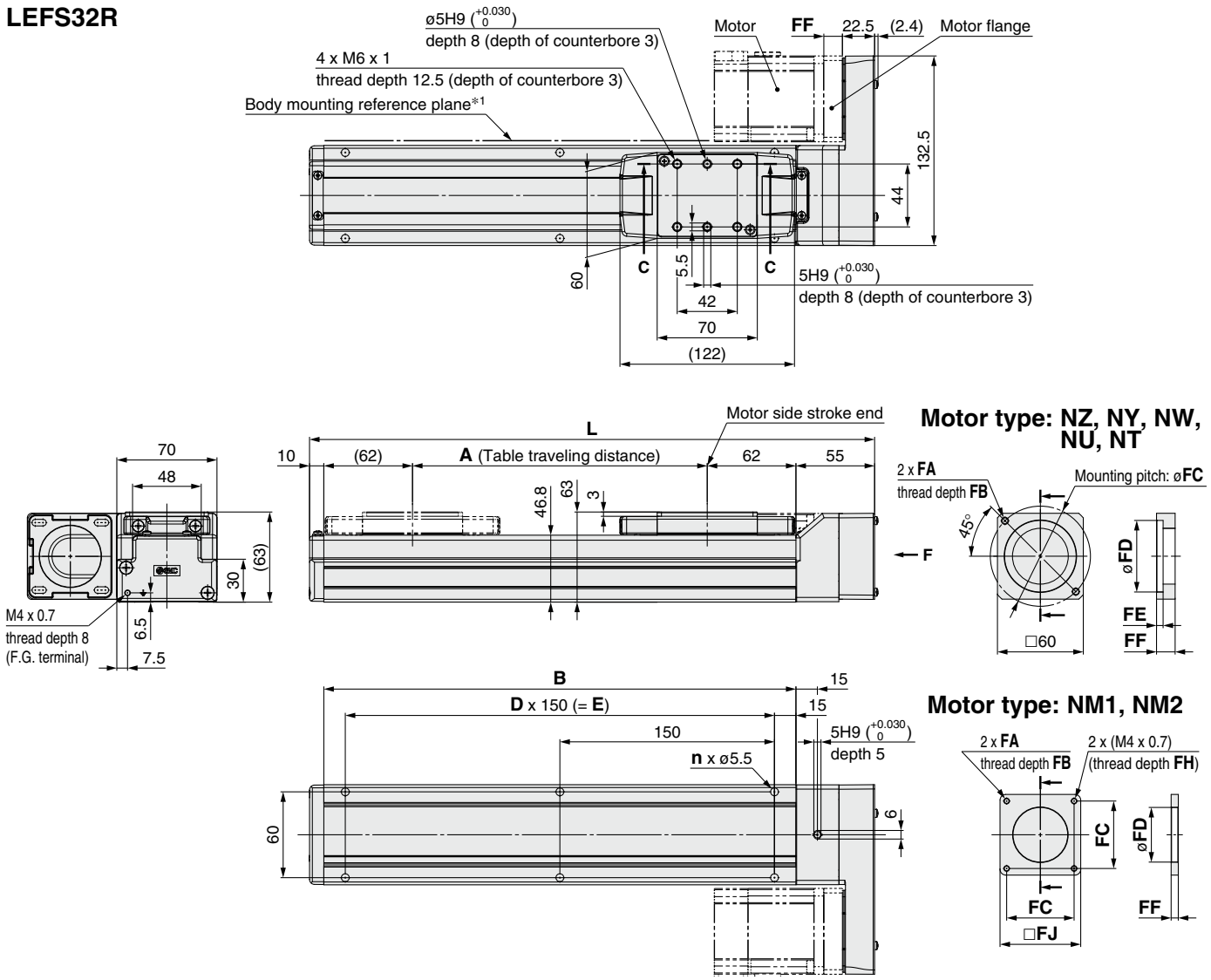

*1 When mounting the actuator using the body mounting reference plane, set the height of the opposite surface or pin to be 3 mm or more. (Recommended height 5 mm)

Dimensions

[mm]

Stroke	L	A	B	n	D	E
50	245	56	180	4	—	—
100	295	106	230	4	—	—
150	345	156	280	4	—	—
200	395	206	330	6	2	300
250	445	256	380	6	2	300
300	495	306	430	6	2	300
350	545	356	480	8	3	450
400	595	406	530	8	3	450
450	645	456	580	8	3	450
500	695	506	630	10	4	600
550	745	556	680	10	4	600
600	795	606	730	10	4	600
650	845	656	780	12	5	750
700	895	706	830	12	5	750
750	945	756	880	12	5	750
800	995	806	930	14	6	900
850	1045	856	980	14	6	900
900	1095	906	1030	14	6	900
950	1145	956	1080	16	7	1050
1000	1195	1006	1130	16	7	1050

Motor Mounting Dimensions

[mm]

Motor type	FA	FB	FC	FD	FE	FF	FJ	FH
NZ/NW	M5 x 0.8	8.5	70	50	4.6	13	—	—
NY	M4 x 0.7	8	70	50	4.6	13	—	—
NU	M5 x 0.8	8.5	70	50	4.6	10.6	—	—
NT	M5 x 0.8	8.5	70	50	4.6	17	—	—
NM1	M4 x 0.7	5	47.14	38.2	—	5	56.4	5
NM2	M4 x 0.7	8	50	38.2	—	11.5	60	7

Refer to the "Motor Mounting" on page 842 for details about motor mounting and included parts.

Dimensions: Ball Screw Drive

LEFS32R

Positioning pin hole*1 (Option): Body bottom

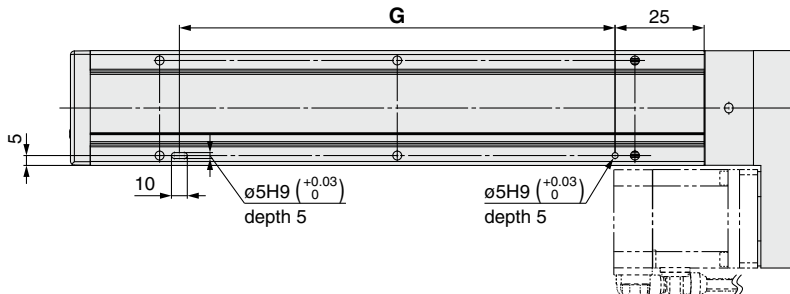

*1 When using the body bottom positioning pin holes, do not simultaneously use the housing B bottom pin hole.

With auto switch (Option)

LEFS32R

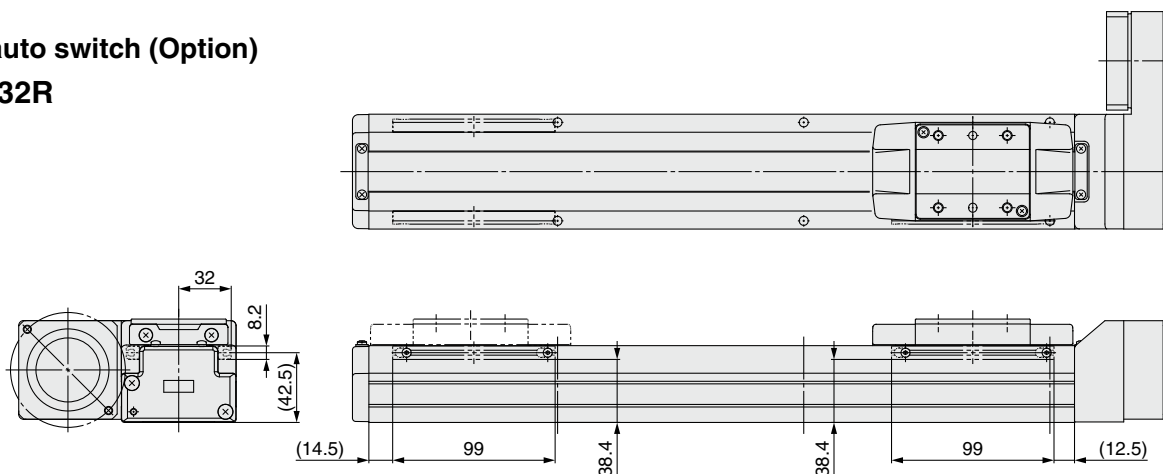

LEFS32L

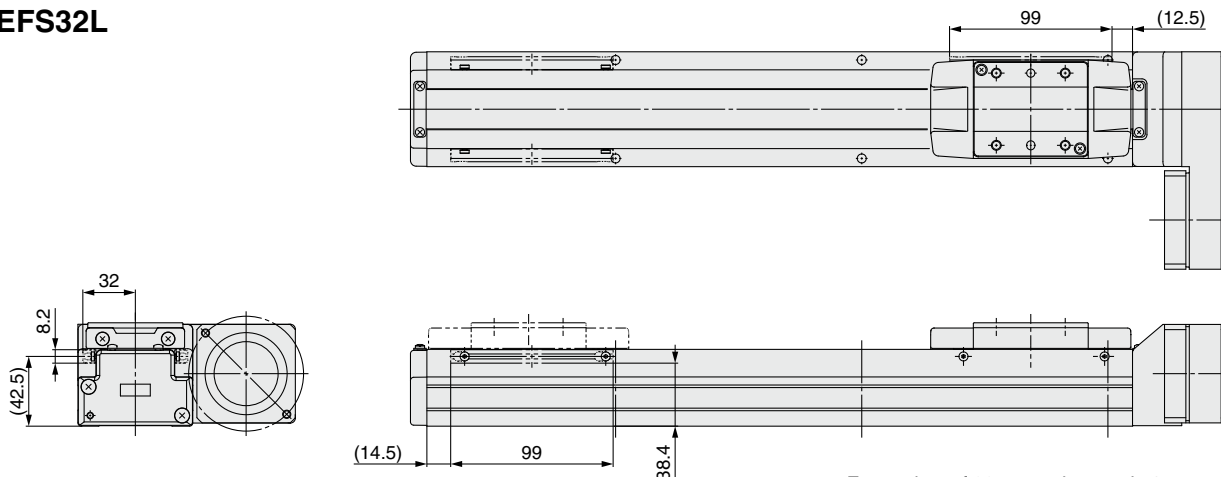

* For strokes of 99 mm or less, only 1 auto switch mounting bracket can be installed on the motor side.

Stroke	G [mm]
50	130
100	130
150	130
200	280
250	280
300	280
350	430
400	430
450	430
500	580

Stroke	G [mm]
550	580
600	580
650	730
700	730
750	730
800	880
850	880
900	880
950	1030
1000	1030

- LEFS
- LEFB
- LEJS
- LEJB
- LEL
- LEM
- LEY
- LEYG
- LES
- LESH
- LEPY
- LEPS
- LER
- LEH
- LEY-X5
- 11-LEFS
- 11-LEJS
- 25A-
- LEC
- JXC
- LECS
- LECS-T
- LECY
- Motorless
- LAT3

LEFS Series

Motorless Type

Refer to the "Motor Mounting" on page 842 for details about motor mounting and included parts.

Dimensions: Ball Screw Drive

LEFS40R

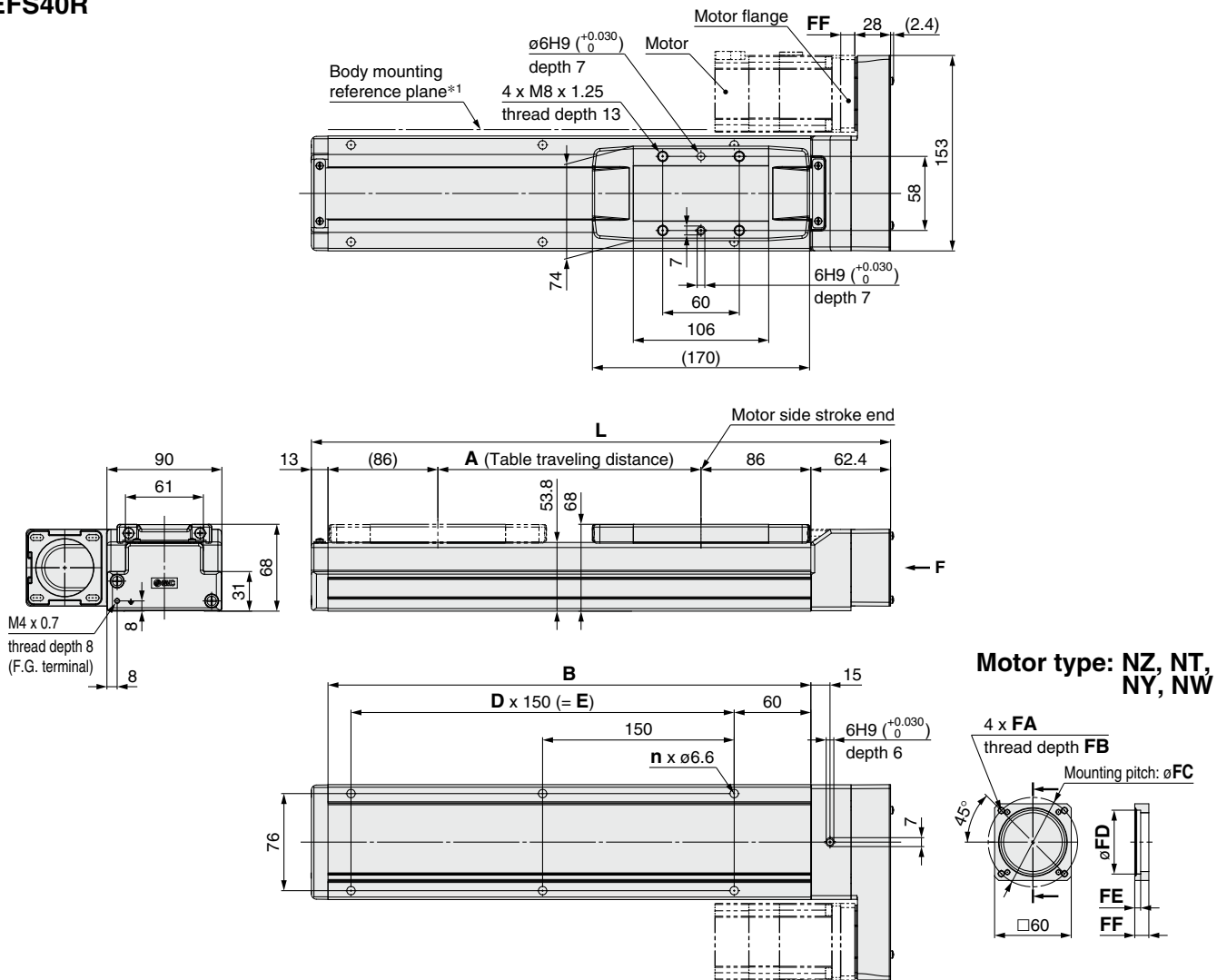

*1 When mounting the actuator using the body mounting reference plane, set the height of the opposite surface or pin to be 3 mm or more. (Recommended height 5 mm)

Dimensions

[mm]

Stroke	L	A	B	n	D	E
150	403.4	156	328	4	—	150
200	453.4	206	378	6	2	300
250	503.4	256	428	6	2	300
300	553.4	306	478	6	2	300
350	603.4	356	528	8	3	450
400	653.4	406	578	8	3	450
450	703.4	456	628	8	3	450
500	753.4	506	678	10	4	600
550	803.4	556	728	10	4	600
600	853.4	606	778	10	4	600
650	903.4	656	828	12	5	750
700	953.4	706	878	12	5	750
750	1003.4	756	928	12	5	750
800	1053.4	806	978	14	6	900
850	1103.4	856	1028	14	6	900
900	1153.4	906	1078	14	6	900
950	1203.4	956	1128	16	7	1050
1000	1253.4	1006	1178	16	7	1050
1100	1353.4	1106	1278	18	8	1200
1200	1453.4	1206	1378	18	8	1200

Motor Mounting Dimensions

[mm]

Motor type	FA	FB	FC	FD	FE	FF
NZ/NW	M5 x 0.8	8.5	70	50	4.6	11
NY	M4 x 0.7	8	70	50	4.6	11
NT	M5 x 0.8	8.5	70	50	4.6	14.5

Refer to the "Motor Mounting" on page 842 for details about motor mounting and included parts.

Dimensions: Ball Screw Drive

LEFS40R

Positioning pin hole*1 (Option): Body bottom

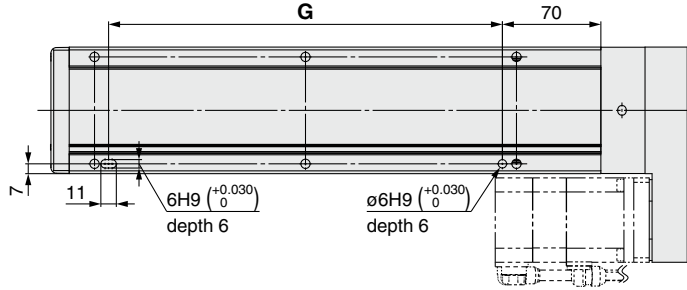

*1 When using the body bottom positioning pin holes, do not simultaneously use the housing B bottom pin hole.

With auto switch (Option)

LEFS40R

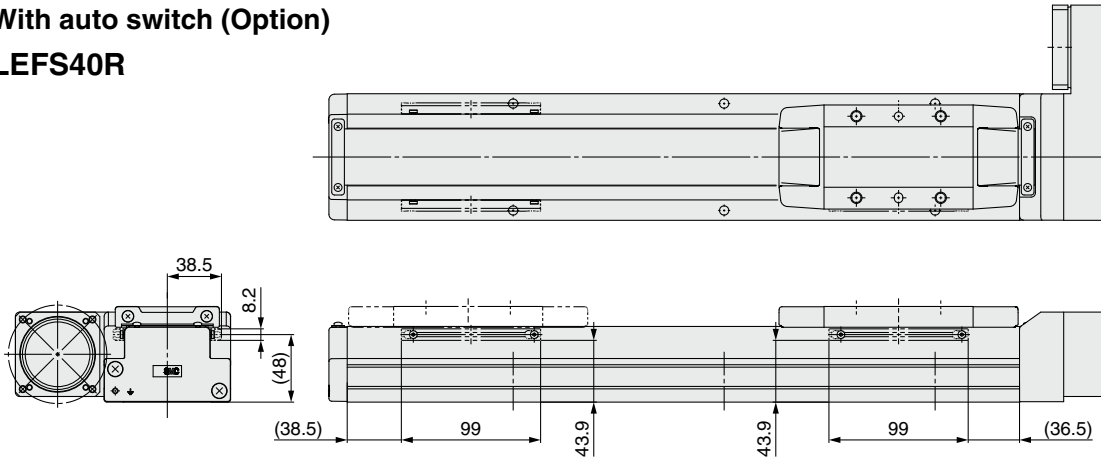

LEFS40L

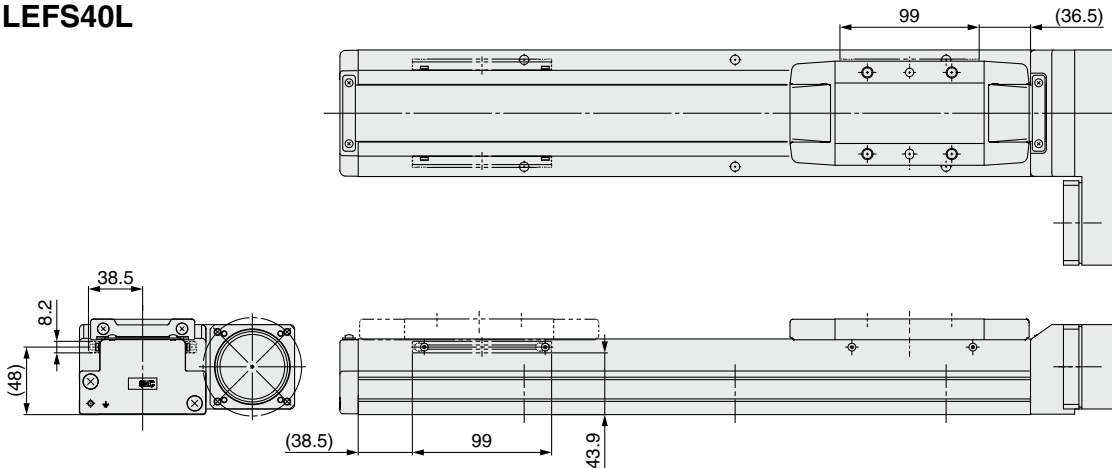

Dimensions [mm]

Stroke	G
150	130
200	280
250	280
300	280
350	430
400	430
450	430
500	580
550	580
600	580

Dimensions [mm]

Stroke	G
650	730
700	730
750	730
800	880
850	880
900	880
950	1030
1000	1030
1100	1180
1200	1180

- LEFS
- LEFB
- LEJS
- LEJB
- LEL
- LEM
- LEJ
- LEYG
- LES
- LESH
- LEPY
- LEPS
- LER
- LEH
- LEY-X5
- 11-LEFS
- 11-LEJS
- 25A-
- LEC
- JXC
- LECS
- LECS-T
- LECY
- Motorless
- LAT3

LEFS Series

Motorless Type

- When mounting a hub/pulley, remove all oil content, dust, dirt, etc., adhered to the shaft and the inside of the hub/pulley beforehand.
- This product does not include the motor and motor mounting screws. (Provided by the customer)
- Prepare a motor with a round shaft end.
For the "NM1" or "NM3," prepare a D-cut shaft.
- Take measures to prevent the loosening of the motor mounting screws and hexagon socket head set screws.

Motor Mounting: In-line

Motor type: NZ, NY, NX, NW, NV, NU, NT, NM2

[Included parts] Hexagon socket head cap screw/MM
(Tightening torque: TT [N·m])

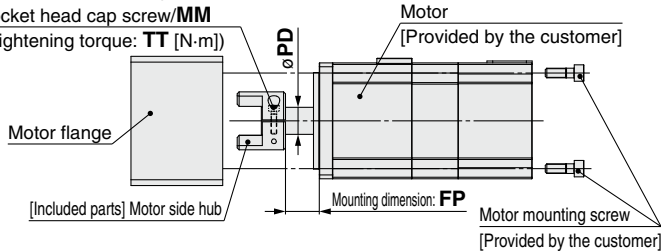

* Note for mounting a motor to the NM2 motor type
Motor mounting screws for the LEFS25 are fixed starting from the motor flange side. (Opposite of the drawing)

Motor type: NM1

[Included parts] Hexagon socket head set screw/MM
(Tightening torque: TT [N·m])

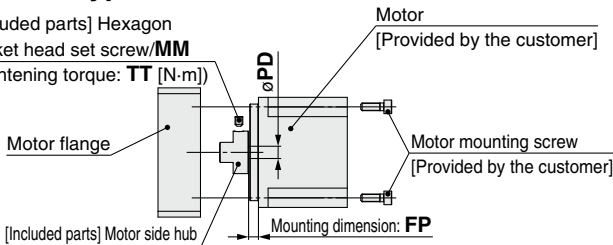

* Note for mounting a hub to the NM1 motor type
When mounting the hub to the motor, make sure to position the set screw vertical to the D-cut surface of the motor shaft. (Refer to the figure shown below.)
* Motor mounting screws for the LEFS25 are fixed starting from the motor flange side. (Opposite of the drawing)

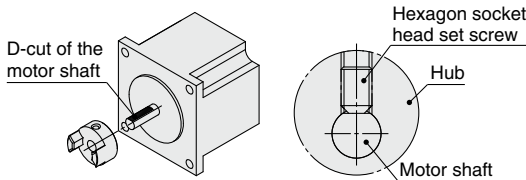

Size: 25 Hub Mounting Dimensions [mm]

Motor type	MM	TT	PD	FP
NZ	M2.5 x 10	1.0	8	12.4
NY	M2.5 x 10	1.0	8	12.4
NX	M2.5 x 10	1.0	8	6.9
NM1	M3 x 4	0.63	5	11.9
NM2	M2.5 x 10	1.0	6	10

Size: 32 Hub Mounting Dimensions [mm]

Motor type	MM	TT	PD	FP
NZ	M3 x 12	1.5	14	17.5
NY	M4 x 12	2.5	11	17.5
NX	M4 x 12	2.5	9	5.2
NW	M4 x 12	2.5	9	13
NV	M4 x 12	2.5	9	5.2
NU	M4 x 12	2.5	11	13
NT	M3 x 12	1.5	12	17.5
NM1	M4 x 5	1.5	6.35	5.4
NM2	M4 x 12	2.5	10	12

Size: 40 Hub Mounting Dimensions [mm]

Motor type	MM	TT	PD	FP
NZ	M3 x 12	1.5	14	17.5
NY	M3 x 12	1.5	14	17.5
NX	M4 x 12	2.5	9	5.2
NW	M4 x 12	2.5	9	13
NV	M4 x 12	2.5	9	5.2
NU	M4 x 12	2.5	11	13
NT	M3 x 12	1.5	12	17.5
NM1	M4 x 5	1.5	6.35	5.1
NM2	M4 x 12	2.5	10	12

Motor Mounting Diagram

Motor type: NZ, NY, NW, NU, NT

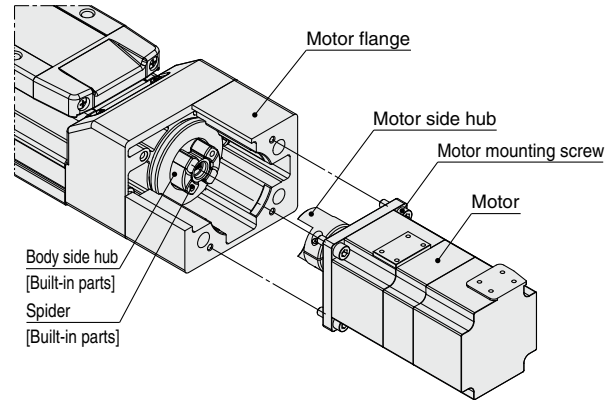

Mounting procedure

- 1) Secure the motor hub to the motor (provided by the customer) with the MM hexagon socket head cap screw.
- 2) Check the motor hub position, and then insert it. (Refer to the mounting diagram.)
- 3) Secure the motor to the motor flange with the motor mounting screws (provided by the customer).

Motor type: NX, NV, NM1, NM2

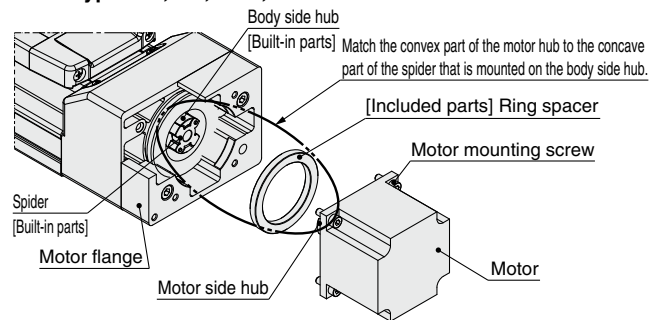

Mounting procedure

- 1) Secure the motor hub to the motor (provided by the customer) with the MM hexagon socket head cap screw (Motor type: NX, NM2) or MM hexagon socket head set screw (Motor type: NM1).
- 2) Check the motor hub position, and then insert it. (Refer to the mounting diagram.)
- 3) Mount the ring spacer to the motor.
- 4) Secure the motor to the motor flange with the motor mounting screws (provided by the customer).
* For the LEFS25
- 4) Remove the motor flange, which has been temporarily mounted, from the housing B, and secure the motor to the motor flange using the motor mounting screws (that are to be prepared by the customer).
- 5) Tighten the motor flange to the housing B using motor flange mounting screws (included parts).

Included Parts List

Size: 25

Description	Quantity				
	Motor type				
	NZ	NY	NX	NM1	NM2
Motor side hub	1	1	1	1	1
Hexagon socket head cap screw/set screw (to secure the hub)*1	1	1	1	1	1
Hexagon socket head cap screw (to secure the motor flange)*1	—	—	—	2	2
Ring spacer	—	—	—	1	1

*1 For screw sizes, refer to the hub mounting dimensions.

Size: 32, 40

Description	Quantity								
	Motor type								
	NZ	NY	NX	NW	NV	NU	NT	NM1	NM2
Motor side hub	1	1	1	1	1	1	1	1	1
Hexagon socket head cap screw/set screw (to secure the hub)*1	1	1	1	1	1	1	1	1	1
Ring spacer	—	—	1	—	1	—	—	1	1

*1 For screw sizes, refer to the hub mounting dimensions.

Motor Mounting: Motor Parallel

Motor type: NZ, NY, NX, NW, NU, NT, NM2

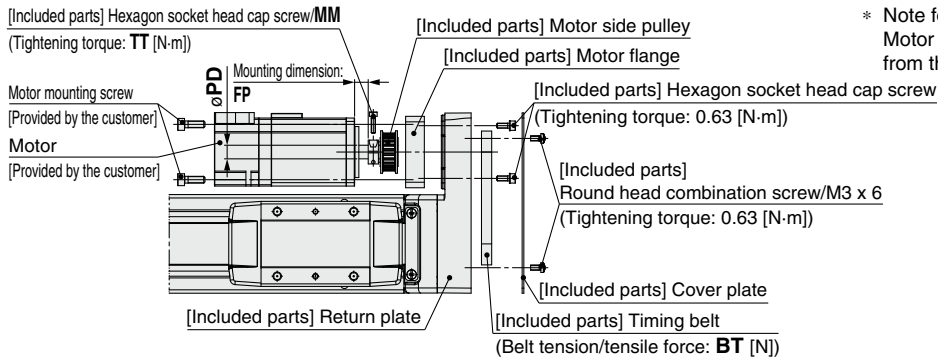

* Note for mounting a motor to the NM2 motor type
Motor mounting screws for the LEFS25 are fixed starting from the motor flange side. (Opposite of the drawing)

Motor type: NM1, NM3

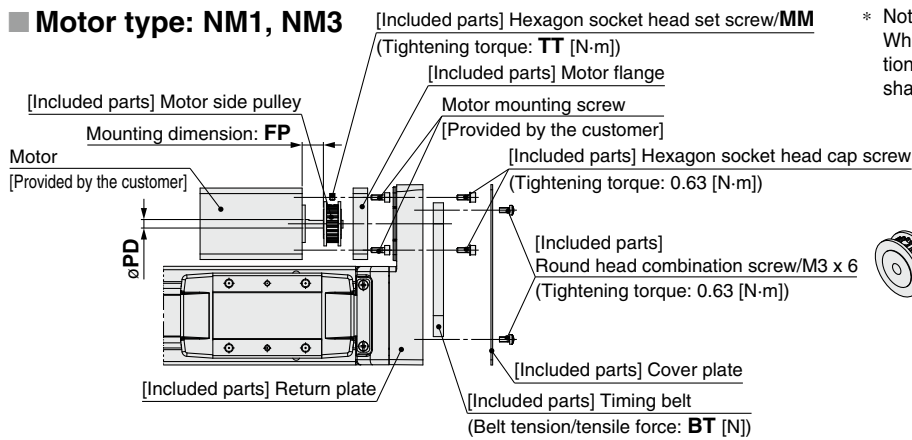

* Note for mounting a pulley to the NM1 and NM3 motor type
When mounting the pulley to the motor, make sure to position the set screw vertical to the D-cut surface of the motor shaft. (Refer to the figure shown below.)

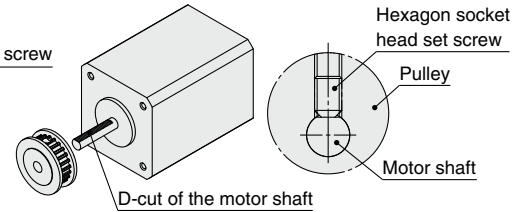

Motor Mounting Diagram

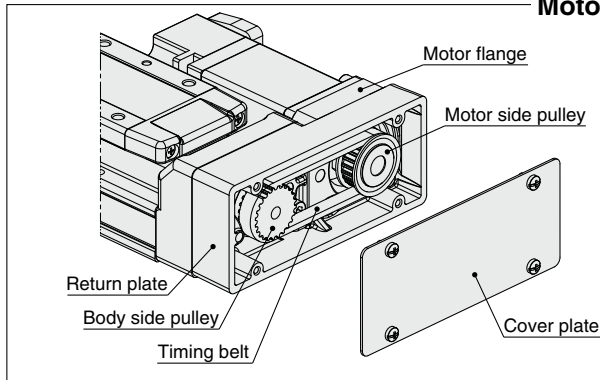

Mounting procedure

- 1) Secure the motor side pulley to the motor (provided by the customer) with the MM hexagon socket head cap screw. For motor type "NM1/NM3", secure them with the MM hexagon socket head set screw.
- 2) Secure the motor to the motor flange with the motor mounting screws (provided by the customer).
- 3) Put the timing belt on the motor side pulley and body side pulley, and then secure it temporarily with the hexagon socket head cap screws (2 x M3 x 8). (Refer to the left diagram.)
- 4) Apply the belt tension and tighten the timing belt with the hexagon socket head cap screws (2 x M3 x 8).
- 5) Secure the return plate with the round head combination screws (4 x M3 x 6).

Size: 25 Pulley Mounting Dimensions [mm]

Motor type	MM	TT	PD	FP	BT
NZ/NY	M2.5 x 10	1.0	8	8	19.6
NX	M2.5 x 10	1.0	8	5	19.6
NM1	M3 x 5	0.63	5	12.5	19.6
NM2	M2.5 x 10	1.0	6	5.5	19.6
NM3	M3 x 5	0.63	5	9.5	19.6

Size: 32 Pulley Mounting Dimensions [mm]

Motor type	MM	TT	PD	FP	BT
NZ	M3 x 12	1.5	14	6.6	49
NY	M3 x 12	1.5	11	6.6	49
NW	M4 x 12	2.5	9	6.6	49
NU	M3 x 12	1.5	11	4.2	49
NT	M3 x 12	1.5	12	10.6	49
NM1	M3 x 4	0.63	6.35	10.6	49
NM2	M3 x 12	1.5	10	5.1	49

Size: 40 Pulley Mounting Dimensions [mm]

Motor type	MM	TT	PD	FP	BT
NZ/NY	M4 x 12	2.5	14	4.5	98.1
NW	M4 x 12	2.5	9	4.5	98.1
NT	M4 x 12	2.5	12	8	98.1

Included Parts List

Size: 25

Description	Quantity
Motor flange	1
Motor side pulley	1
Cover plate	1
Timing belt	1
Hexagon socket head cap screw/set screw (to secure the pulley)*1	1
Hexagon socket head cap screw M3 x 8 (to secure the motor flange)	2
Round head combination screw M3 x 6	4

*1 For screw sizes, refer to the pulley mounting dimensions.

Size: 32, 40

Description	Quantity	
	32	40
Motor flange	1	1
Motor side pulley	1	1
Cover plate	1	1
Timing belt	1	1
Hexagon socket head cap screw/set screw (to secure the pulley)*1	1	1
Hexagon socket head cap screw M4 x 12 (to secure the motor flange)	2	4
Round head combination screw M3 x 6	4	4

*1 For screw sizes, refer to the pulley mounting dimensions.

LEFS Series Motor Mounting Parts

Motor Flange Option

A motor can be added to the motorless specification after purchase. The applicable motor types are shown below. (Except NM1 and NM3)
Use the following part numbers to select a compatible motor flange option and place an order.

How to Order

LEFS-MF 25 - NZ

Ball screw drive •

① ② ③

① Size

25	For LEF□25
32	For LEF□32
40	For LEF□40

② Motor mounting position

Nil	In-line
P	(Right side/Left side) parallel

③ Motor type

Symbol	Type	Symbol	Type
NZ	Mounting type Z	NV	Mounting type V
NY	Mounting type Y	NU	Mounting type U
NX	Mounting type X	NT	Mounting type T
NW	Mounting type W	NM2	Mounting type M2

* Select only NZ, NY, NX or NM2 for the LEFS-MF25.

Compatible Motors

Applicable motor model			Size/Motor type												
Manufacturer	Series	Type	25				32/40								
			NZ Mounting type Z	NY Mounting type Y	NX Mounting type X	NM2 Mounting type M2	NZ Mounting type Z	NY Mounting type Y	NX Mounting type X	NW Mounting type W	NV Mounting type V	NU Mounting type U	NT Mounting type T	NM2 Mounting type M2	
Mitsubishi Electric Corporation	MELSERVO-JN	HF-KN	●	—	—	—	●	—	—	—	—	—	—	—	—
	MELSERVO-J4	HG-KR	●	—	—	—	●	—	—	—	—	—	—	—	—
	MELSERVO-J5	HK-KT	●	—	—	—	●	—	—	—	—	—	—	—	—
YASKAWA Electric Corporation	Σ-V	SGMJV	●	—	—	—	●	—	—	—	—	—	—	—	—
	Σ-7	SGM7J/SGM7A	●	—	—	—	●	—	—	—	—	—	—	—	—
SANYO DENKI CO., LTD.	SANMOTION R	R2	●	—	—	—	●	—	—	—	—	—	—	—	—
OMRON Corporation	Sysmac G5	R88M-K	●	—	—	—	—	●	—	—	—	—	—	—	—
	1 S	R88M-1	●	—	—	—	—	●	—	—	—	—	—	—	—
Panasonic Corporation	MINAS A5	MSM□/MHMD	—	●	—	—	—	●	—	—	—	—	—	—	—
	MINAS A6	MSMF	—	●	—	—	—	●	—	—	—	—	—	—	—
		MHMF	●	—	—	—	—	●	—	—	—	—	—	—	—
FANUC CORPORATION	βis (-B)	β	●	—	—	—	● (β1 only)	—	—	●	—	—	—	—	—
NIDEC SANKYO CORPORATION	S-FLAG	MA/MH/MM	●	—	—	—	●	—	—	—	—	—	—	—	—
KEYENCE CORPORATION	SV	SV-M/SV-B	●	—	—	—	●	—	—	—	—	—	—	—	—
	SV2	SV2-M/SV2-B	●	—	—	—	●	—	—	—	—	—	—	—	—
FUJI ELECTRIC CO., LTD.	ALPHA5	GYS/GYB	●	—	—	—	●	—	—	—	—	—	—	—	—
	ALPHA7	GYS/GYB	●	—	—	—	●	—	—	—	—	—	—	—	—
	FALDIC α	GYS	●	—	—	—	●	—	—	—	—	—	—	—	—
ORIENTAL MOTOR Co., Ltd.	AR/AZ	AR/AZ (46 only)	—	—	—	●	—	—	—	—	—	—	—	—	—
	AR/AZ	AR/AZ	—	—	—	—	—	—	—	—	—	—	—	—	●*2
Rockwell Automation, Inc. (Allen-Bradley)	MP-/VP-	MP/VP	—	—	—	—	—	—	●*1	—	—	—	—	—	—
	TL	TLY-A	●	—	—	—	—	—	—	—	—	—	—	●	—
Beckhoff Automation GmbH	AM	AM30	●	—	—	—	—	—	—	—	—	●*1	—	—	—
	AM	AM31	●	—	—	—	—	—	—	—	—	—	—	●*2	—
	AM	AM80/AM81	●	—	—	—	—	—	—	●*1	—	—	—	—	—
Siemens AG	1FK7	1FK7	—	—	●	—	—	—	—	●*1	—	—	—	—	—
Delta Electronics, Inc.	ASDA-A2	ECMA	●	—	—	—	●	—	—	—	—	—	—	—	—
ANCA Motion	AMD2000	Alpha	●	—	—	—	●	—	—	—	—	—	—	—	—

* When the LEF□□□□^{NM1}□□^{NM3}□□ is purchased, it is not possible to change to other motor types.

*1 Motor mounting position: In-line only

*2 Only size 32 is available when the motor mounting position is right (or left) side parallel.

*3 Motor mounting position: Right (or left) side parallel only

Dimensions: Motor Flange Option

Motor mounting position: In-line

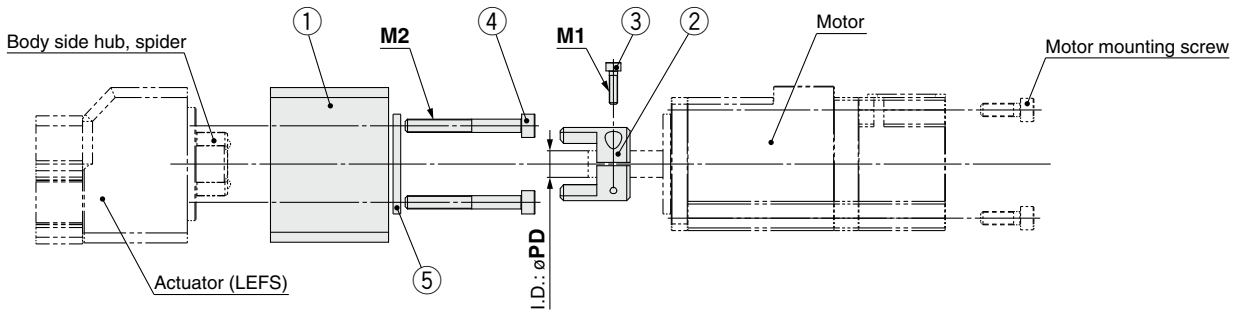

Component Parts

No.	Description	Quantity
1	Motor flange	1
2	Hub (Motor side)	1
3	Hexagon socket head cap screw (to secure the hub)	1
4	Hexagon socket head cap screw (to mount the motor flange)	2
5	Ring spacer (Only for NX, NV and NM2 of size 32, 40)	1

Motor flange details

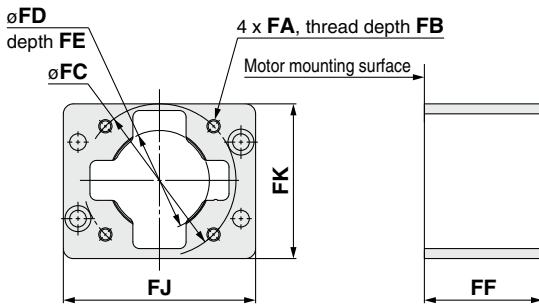

For NM2

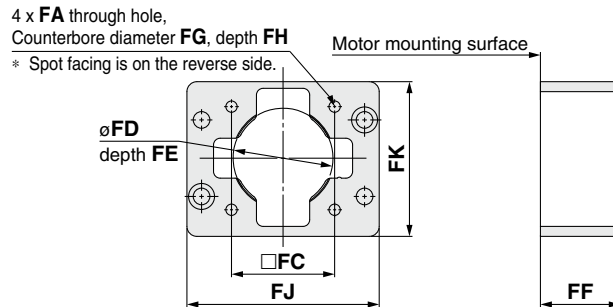

Dimensions

Size	Motor type	FA	FB	FC	FD	FE	FF	FG	FH	FJ	FK	M1	M2	PD
25	NZ/NX	M4 x 0.7	8	46	30	3.5	35.5	—	—	57.8	46.5	M2.5 x 10	M4 x 35	8
	NY	M3 x 0.5	8	45	30	3.5	35.5	—	—	57.8	46.5	M2.5 x 10	M4 x 35	8
	NM2	ø3.4	—	31	22*1	2.5*1	33.1	6.5	22.6	57.8	46.5	M2.5 x 10	M4 x 18	6
32	NZ	M5 x 0.8	9	70	50	5	46	—	—	69.8	61.4	M3 x 12	M5 x 40	14
	NY	M4 x 0.7	8	70	50	5	46	—	—	69.8	61.4	M4 x 12	M5 x 40	11
	NX	M5 x 0.8	9	63	50	5	49.7	—	—	69.8	61.4	M4 x 12	M5 x 40	9
	NW	M5 x 0.8	9	70	50	5	47.5	—	—	69.8	61.4	M4 x 12	M5 x 40	9
	NV	M4 x 0.7	8	63	50	5	49.7	—	—	69.8	61.4	M4 x 12	M5 x 40	9
	NU	M5 x 0.8	9	70	50	5	47.5	—	—	69.8	61.4	M4 x 12	M5 x 40	11
	NT	M5 x 0.8	9	70	50	5	46	—	—	69.8	61.4	M3 x 12	M5 x 40	12
	NM2	M4 x 0.7	8	50	36*1	4.5*1	40.1	—	—	69.8	61.4	M4 x 12	M5 x 25	10
40	NZ	M5 x 0.8	9	70	50	5	47.5	—	—	89.8	66.9	M3 x 12	M5 x 40	14
	NY	M4 x 0.7	8	70	50	5	47.5	—	—	89.8	66.9	M3 x 12	M5 x 40	14
	NX	M5 x 0.8	9	63	50	5	51	—	—	89.8	66.9	M4 x 12	M5 x 40	9
	NW	M5 x 0.8	9	70	50	5	48.8	—	—	89.8	66.9	M4 x 12	M5 x 40	9
	NV	M4 x 0.7	8	63	50	5	51	—	—	89.8	66.9	M4 x 12	M5 x 40	9
	NU	M5 x 0.8	9	70	50	5	48.8	—	—	89.8	66.9	M4 x 12	M5 x 40	11
	NT	M5 x 0.8	9	70	50	5	47.5	—	—	89.8	66.9	M3 x 12	M5 x 40	12
	NM2	M4 x 0.7	8	50	36*1	4.5*1	41.4	—	—	89.8	66.9	M4 x 12	M5 x 25	10

*1 Dimensions after mounting a ring spacer

LEFS
LEFB
LEJS
LEJB
LEL
LEM
LEY
LEYG
LES
LESH
LEPY
LEPS
LER
LEH
LEH
LEY-X5
11-LEFS
11-LEJS
25A-
LEC
JXC
LECS
LECS-T
LECY
Motor/less
LAT3

LEFS Series

Dimensions: Motor Flange Option

Motor mounting position: Motor parallel

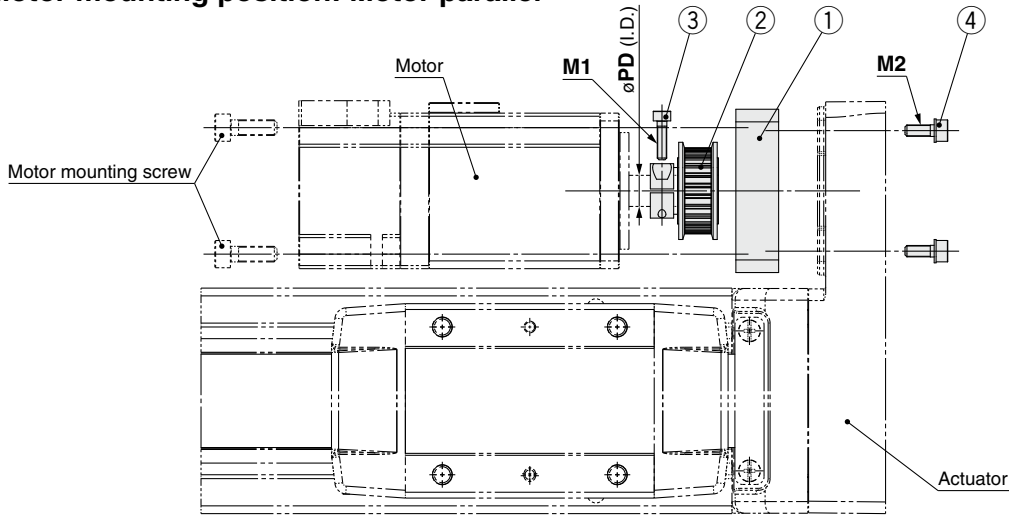

Component Parts

No.	Description	Quantity	
		25, 32	40
1	Motor flange	1	1
2	Motor pulley	1	1
3	Hexagon socket head cap screw (to secure the pulley)	1	1
4	Hexagon socket head cap screw (to mount the motor flange)	2	4

Motor flange details

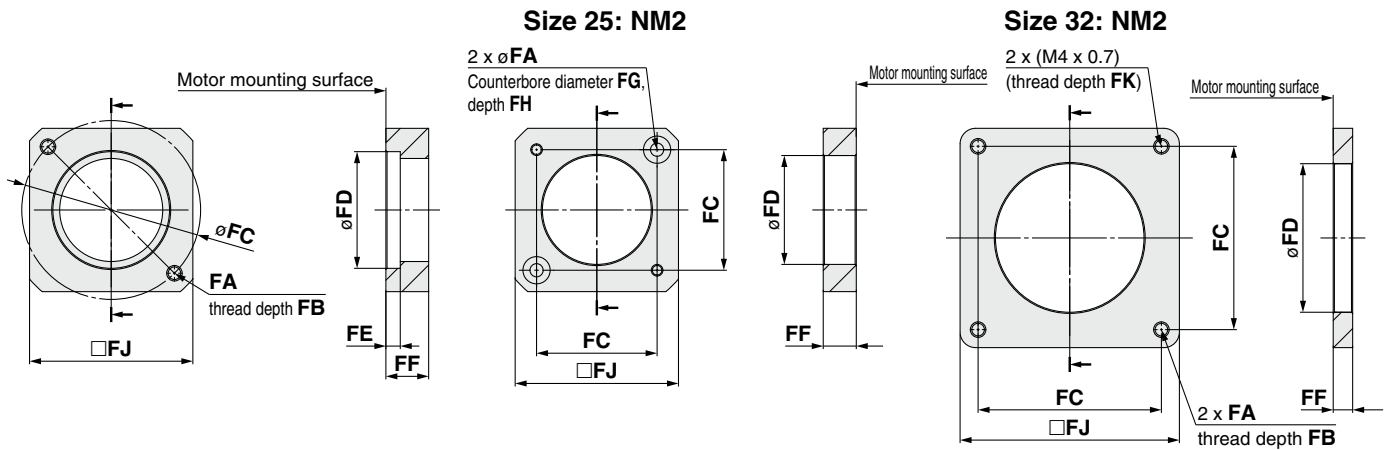

Dimensions

Size	Motor type	FA	FB	FC	FD	FE	FF	FG	FH	FJ	FK	M1	M2	PD
25	NZ	2 x M4 x 0.7	7.5	46	30	3.7	11	—	—	42	—	M2.5 x 10	M3 x 8	8
	NY	2 x M3 x 0.5	5.5	45	30	5	11	—	—	38	—	M2.5 x 10	M3 x 8	8
	NX	2 x M4 x 0.7	7	46	30	3.7	8	—	—	42	—	M2.5 x 10	M3 x 8	8
	NM2	$\phi 3.4$	—	31	28	—	8.5	7	3.5	42	—	M2.5 x 10	M3 x 8	6
32	NZ	2 x M5 x 0.8	8.5	70	50	4.6	13	—	—	60	—	M3 x 12	M4 x 12	14
	NY	2 x M4 x 0.7	8	70	50	4.6	13	—	—	60	—	M3 x 12	M4 x 12	11
	NW	2 x M5 x 0.8	8.5	70	50	4.6	13	—	—	60	—	M4 x 12	M4 x 12	9
	NU	2 x M5 x 0.8	8.5	70	50	4.6	10.6	—	—	60	—	M3 x 12	M4 x 12	11
	NT	2 x M5 x 0.8	8.5	70	50	4.6	17	—	—	60	—	M3 x 12	M4 x 12	12
	NM2	M4 x 0.7	8	50	38.2	—	11.5	—	—	60	7	M3 x 12	M4 x 12	10
40	NZ	4 x M5 x 0.8	8.5	70	50	4.6	11	—	—	60	—	M4 x 12	M4 x 12	14
	NY	4 x M4 x 0.7	8	70	50	4.6	11	—	—	60	—	M4 x 12	M4 x 12	14
	NW	4 x M5 x 0.8	8.5	70	50	4.6	11	—	—	60	—	M4 x 12	M4 x 12	9
	NT	4 x M5 x 0.8	8.5	70	50	4.6	14.5	—	—	60	—	M4 x 12	M4 x 12	12

Motorless Type
Electric Actuator/Slider Type
Belt Drive/LEFB Series
Model Selection

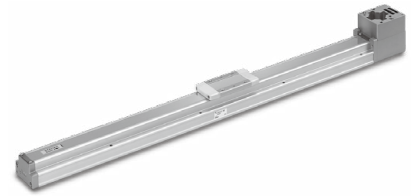

LEFB Series ▶ p. 851

Selection Procedure



Selection Example

The model selection method shown below corresponds to SMC's standard motor. For use in combination with a motor from a different manufacturer, check the available product information of the motor to be used.

Operating conditions

- Workpiece mass: 20 [kg]
 - Speed: 1500 [mm/s]
 - Acceleration/Deceleration: 3000 [mm/s²]
 - Stroke: 2000 [mm]
 - Mounting position: Horizontal upward
- Workpiece mounting condition:

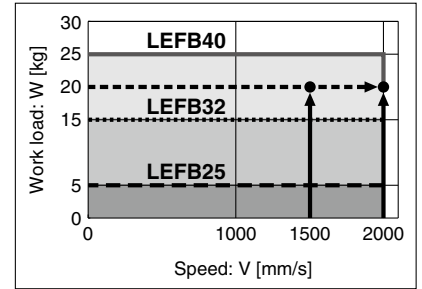
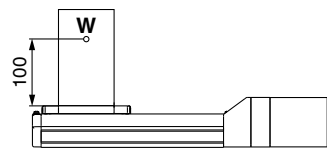

<Speed-Work Load Graph>
(LEFB40)

Step 1 Check the work load-speed. <Speed-Work Load Graph>

Select a model based on the workpiece mass and speed which are within the range of the actuator body specifications while referencing the speed-work load graph (guide) on page 847.

Selection example) The LEFB40□S-2000 can be temporarily selected as a possible candidate based on the graph shown on the right side.

* Refer to the selection method of motor manufacturers for regeneration resistance.

Step 2 Check the cycle time.

Calculate the cycle time using the following calculation method.

Cycle time:

T can be found from the following equation.

$$T = T1 + T2 + T3 + T4 [s]$$

- T1: Acceleration time and T3: Deceleration time can be found by the following equation.

$$T1 = V/a1 [s] \quad T3 = V/a2 [s]$$

- T2: Constant speed time can be found from the following equation.

$$T2 = \frac{L - 0.5 \cdot V \cdot (T1 + T3)}{V} [s]$$

- T4: Settling time varies depending on the motor type and load. The value below is recommended.

$$T4 = 0.05 [s]$$

* The conditions for the settling time vary depending on the motor or driver to be used.

Calculation example)

T1 to T4 can be calculated as follows.

$$T1 = V/a1 = 1500/3000 = 0.5 [s]$$

$$T3 = V/a2 = 1500/3000 = 0.5 [s]$$

$$T2 = \frac{L - 0.5 \cdot V \cdot (T1 + T3)}{V} = \frac{2000 - 0.5 \cdot 1500 \cdot (0.5 + 0.5)}{1500} = 0.83 [s]$$

$$T4 = 0.05 [s]$$

The cycle time can be found as follows.

$$T = T1 + T2 + T3 + T4 = 0.5 + 0.83 + 0.5 + 0.05 = 1.88 [s]$$

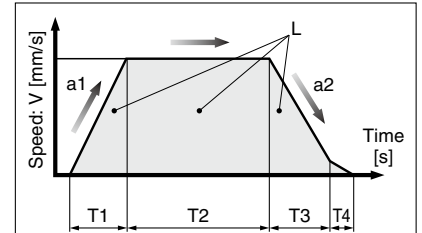

- L : Stroke [mm] ... (Operating condition)
- V : Speed [mm/s] ... (Operating condition)
- a1: Acceleration [mm/s²] ... (Operating condition)
- a2: Deceleration [mm/s²] ... (Operating condition)

- T1: Acceleration time [s]
Time until reaching the set speed
- T2: Constant speed time [s]
Time while the actuator is operating at a constant speed
- T3: Deceleration time [s]
Time from the beginning of the constant speed operation to stop
- T4: Settling time [s]
Time until positioning is completed

Step 3 Check the guide moment.

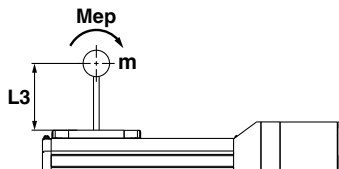

Based on the above calculation result, the LEFB40□S-2000 should be selected.

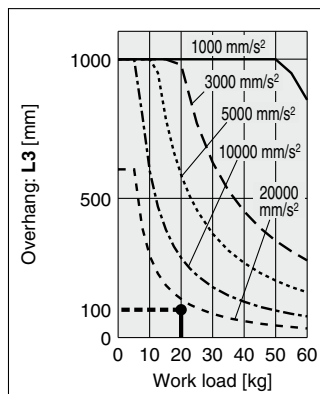

- LEFB
- LEJBS
- LEJBB
- LEL
- LEM
- LEYS
- LEYG
- LES
- LESH
- LEPY
- LEPS
- LER
- LEH
- LEH-X5
- LEYS-X5
- 11-LEFS
- 11-LEJS
- 25A-
- LEC□
- LEC
- JXC□
- LECS□
- LECS□-T
- LECY□
- Motorless
- LAT3

LEFB Series

Motorless Type

Speed-Work Load Graph (Guide)

LEFB□/Belt Drive

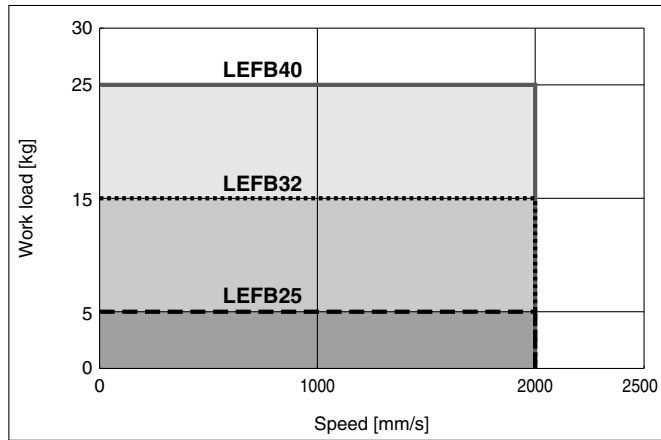

Cycle Time Graph (Guide)

LEFB□/Belt Drive

LEFB25/32/40

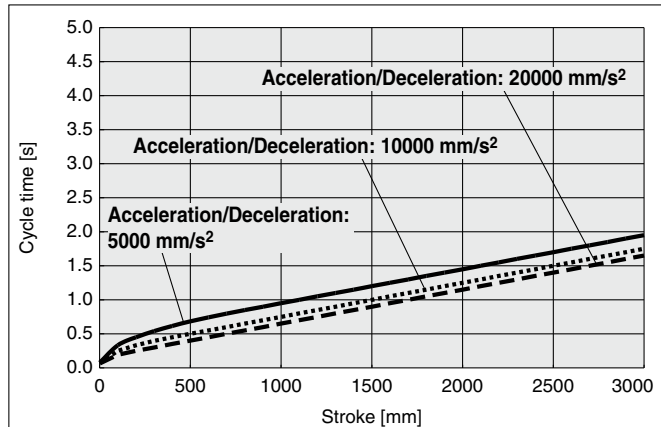

- * Cycle time is for when maximum speed.
- * Maximum stroke: LEFB25: 2000 mm
LEFB32: 2500 mm
LEFB40: 3000 mm

* The values shown below are allowable values of the actuator body.
Do not use the actuator so that it exceeds these specification ranges.

Work Load-Acceleration/Deceleration Graph (Guide)

LEFB□/Belt Drive

LEFB25□ (Duty ratio)

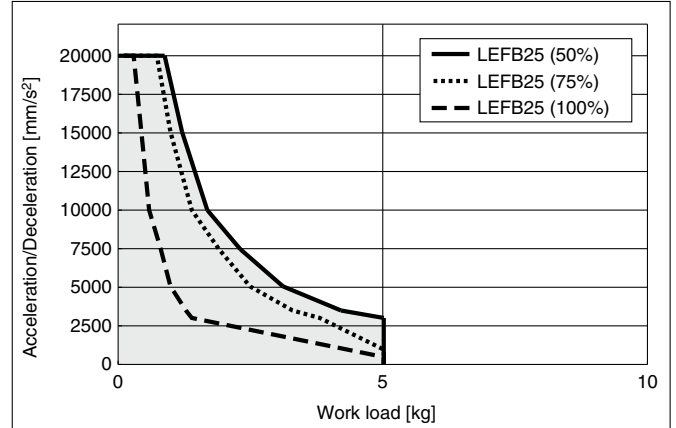

LEFB32□ (Duty ratio)

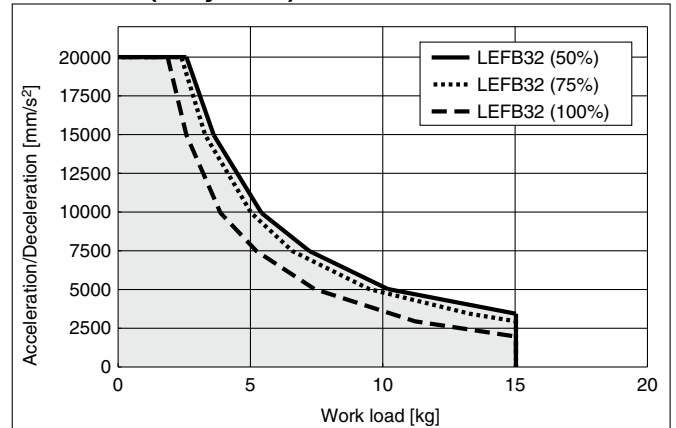

LEFB40□ (Duty ratio)

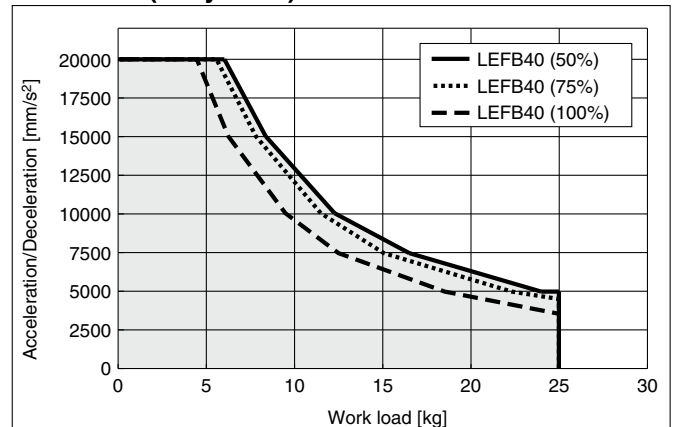

These graphs are examples of when the standard motor is mounted.
Determine the duty ratio after taking into account the load factor of the motor or driver to be used.

* This graph shows the amount of allowable overhang (guide unit) when the center of gravity of the workpiece overhangs in one direction. When selecting the overhang, refer to the "Calculation of Guide Load Factor" or the Electric Actuator Model Selection Software for confirmation: <https://www.smcworld.com>

Dynamic Allowable Moment

Acceleration/Deceleration ——— 1000 mm/s² - - - 3000 mm/s² ····· 5000 mm/s² - - - - 10000 mm/s² - - - - - 20000 mm/s²

Orientation		Model		
Load overhanging direction m : Work load [kg] Me: Dynamic allowable moment [N·m] L : Overhang to the work load center of gravity [mm]		LEFB25□	LEFB32□	LEFB40□
Horizontal/Bottom	X 			
	Y 			
	Z 			
Wall	X 			
	Y 			
	Z 			

- LEFS
- LEFB
- LEJS
- LEJB
- LEL
- LEM
- LEY
- LEYG
- LES
- LESH
- LEPY
- LEPS
- LER
- LEH
- LEY-X5
- 11-LEFS
- 11-LEJS
- 25A-
- LEC□
- JXC□
- LECS□
- LECS□-T
- LECY□
- Motorless
- LAT3

Calculation of Guide Load Factor

- Decide operating conditions.

Model: LEFB

Size: 25/32/40

Mounting orientation: Horizontal/Bottom/Wall

Acceleration [mm/s^2]: a

Work load [kg]: m

Work load center position [mm]: $X_c/Y_c/Z_c$

- Select the target graph while referencing the model, size, and mounting orientation.

- Based on the acceleration and work load, find the overhang [mm]: $L_x/L_y/L_z$ from the graph.

- Calculate the load factor for each direction.

$$\alpha_x = X_c/L_x, \alpha_y = Y_c/L_y, \alpha_z = Z_c/L_z$$

- Confirm the total of α_x , α_y , and α_z is 1 or less.

$$\alpha_x + \alpha_y + \alpha_z \leq 1$$

When 1 is exceeded, consider a reduction of acceleration and work load, or a change of the work load center position and series.

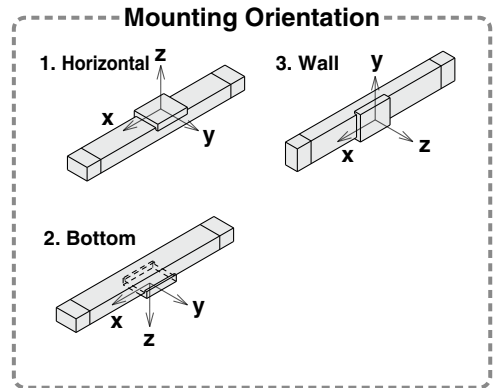

Example

- Operating conditions

Model: LEFB40

Size: 40

Mounting orientation: Horizontal

Acceleration [mm/s^2]: 3000

Work load [kg]: 20

Work load center position [mm]: $X_c = 0, Y_c = 50, Z_c = 200$

- Select the graphs for horizontal of the LEFB40□ on page 848.

- $L_x = 250 \text{ mm}, L_y = 180 \text{ mm}, L_z = 1000 \text{ mm}$

- The load factor for each direction can be found as follows.

$$\alpha_x = 0/250 = 0$$

$$\alpha_y = 50/180 = 0.27$$

$$\alpha_z = 200/1000 = 0.2$$

- $\alpha_x + \alpha_y + \alpha_z = 0.47 \leq 1$

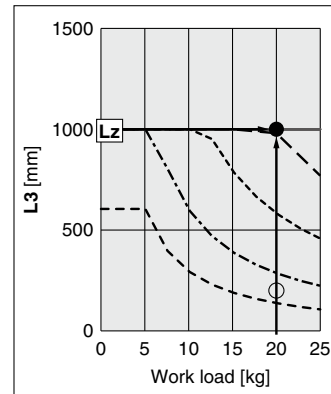
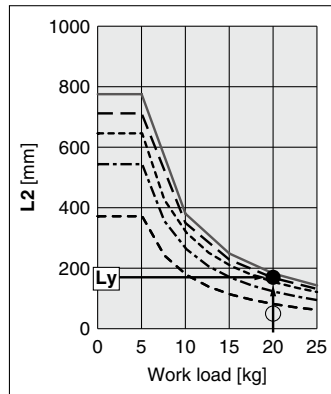
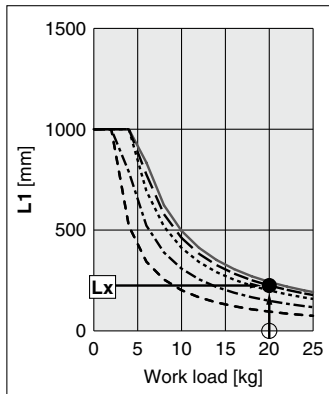
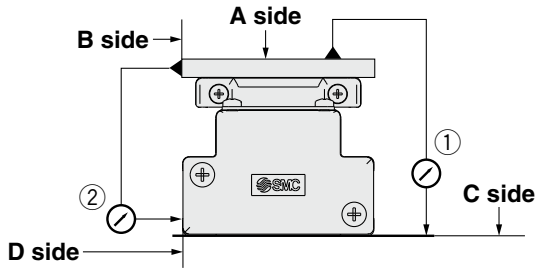

Table Accuracy (Reference Value)



Model	Traveling parallelism [mm] (Every 300 mm)	
	① C side traveling parallelism to A side	② D side traveling parallelism to B side
LEFB25	0.05	0.03
LEFB32	0.05	0.03
LEFB40	0.05	0.03

* Traveling parallelism does not include the mounting surface accuracy.

Table Displacement (Reference Value)

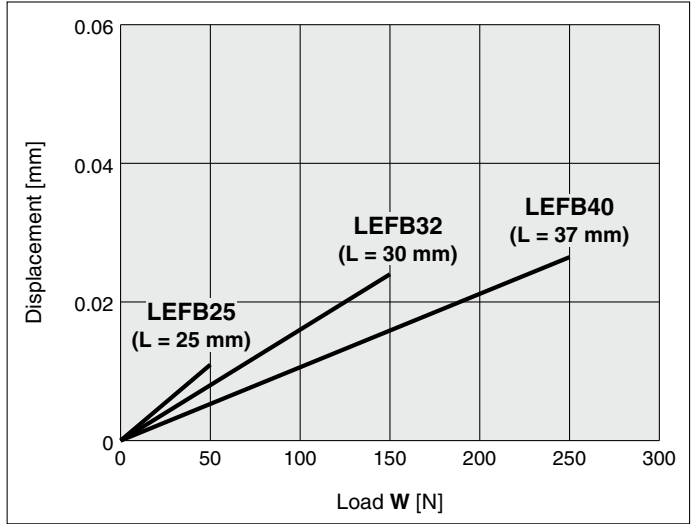
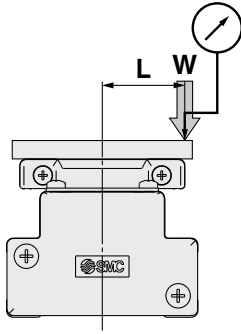

* This displacement is measured when a 15 mm aluminum plate is mounted and fixed on the table.
* Check the clearance and play of the guide separately.

Overhang Displacement Due to Table Clearance (Initial Reference Value)

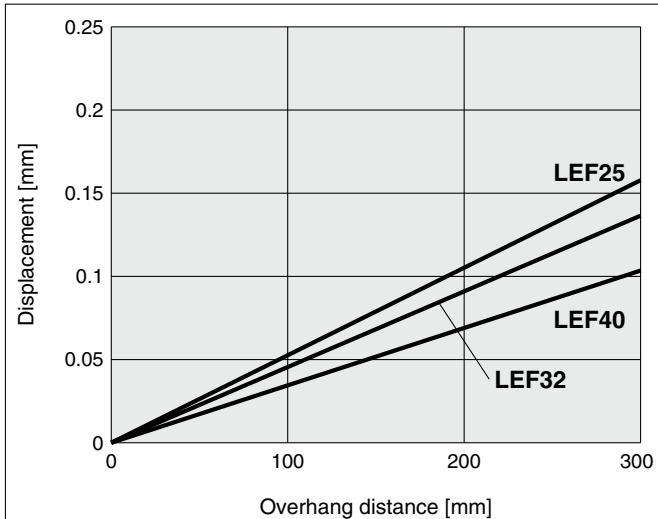

- LEFS
- LEFB
- LEJS
- LEJB
- LEL
- LEM
- LEY
- LEYG
- LES
- LESH
- LEPY
- LEPS
- LER
- LEH
- LEY-X5
- 11-LEFS
- 11-LEJS
- 25A-
- LEC
- JXC
- LECS
- LECS-T
- LECY
- Motorless
- LAT3

Electric Actuator/Slider Type Belt Drive

LEFB Series LEFB25, 32, 40

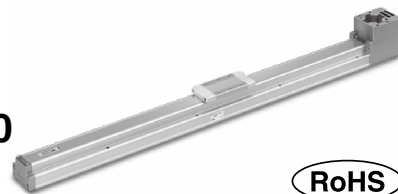

How to Order

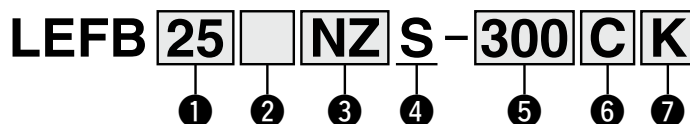

① Size

25
32
40

② Motor mounting position

Nil	Top mounting
U	Bottom mounting

③ Motor type

Symbol	Type
NZ	Mounting type Z
NY	Mounting type Y
NX	Mounting type X
NW	Mounting type W
NV	Mounting type V
NU	Mounting type U
NT	Mounting type T
NM1	Mounting type M1
NM2	Mounting type M2

④ Equivalent lead [mm]

S	54
---	----

⑤ Stroke [mm]

300	300
to	to
3000	3000

⑥ Auto switch compatibility

Nil	None
C	With (Includes 1 mounting bracket)

- * If 2 or more are required, please order them separately. (Part no.: LEF-D-2-1 For details, refer to page 868.)
- * Order auto switches separately. (For details, refer to pages 869 to 871.)
- * When "Nil" is selected, the product will not come with a built-in magnet for an auto switch, and so a mounting bracket cannot be secured. Be sure to select an appropriate model initially as the product cannot be changed to have auto switch compatibility after purchase.

⑦ Positioning pin hole

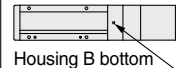
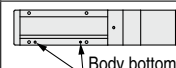
Nil	Housing B bottom*1	
K	Body bottom 2 locations	

*1 Refer to the body mounting example on page 873 for the mounting method.

Applicable Stroke Table

●: Standard/○: Produced upon receipt of order

	300	400	500	600	700	800	900	1000	1100	1200	1300	1400	1500	1600	1700	1800	1900	2000	2500	3000	
LEFB25	●	●	●	●	●	●	●	●	○	●	○	○	●	○	○	○	○	○	●	—	—
LEFB32	●	●	●	●	●	●	●	●	○	●	○	○	●	○	○	○	○	○	●	●	—
LEFB40	●	●	●	●	●	●	●	●	○	●	○	○	●	○	○	○	○	○	●	●	●

* Please consult with SMC as all non-standard and non-made-to-order strokes are produced as special orders.

Compatible Motors

Applicable motor model			Size/Motor type																			
Manufacturer	Series	Type	25						32/40													
			NZ Mounting type Z	NY Mounting type Y	NX Mounting type X	NM1 Mounting type M1	NM2 Mounting type M2	NZ Mounting type Z	NY Mounting type Y	NX Mounting type X	NW Mounting type W	NV Mounting type V	NU Mounting type U	NT Mounting type T	NM1 Mounting type M1	NM2 Mounting type M2						
Mitsubishi Electric Corporation	MELSERVO-JN	HF-KN	●	—	—	—	—	●	—	—	—	—	—	—	—	—	—	—	—	—	—	
	MELSERVO-J4	HG-KR	●	—	—	—	—	●	—	—	—	—	—	—	—	—	—	—	—	—	—	
	MELSERVO-J5	HK-KT	●	—	—	—	—	●	—	—	—	—	—	—	—	—	—	—	—	—	—	
YASKAWA Electric Corporation	Σ-V	SGMJV	●	—	—	—	—	●	—	—	—	—	—	—	—	—	—	—	—	—	—	
	Σ-7	SGM7J/SGM7A	●	—	—	—	—	●	—	—	—	—	—	—	—	—	—	—	—	—	—	
SANYO DENKI CO., LTD.	SANMOTION R	R2	●	—	—	—	—	●	—	—	—	—	—	—	—	—	—	—	—	—	—	
OMRON Corporation	Sysmac G5	R88M-K	●	—	—	—	—	●	—	—	—	—	—	—	—	—	—	—	—	—	—	
	1 S	R88M-1	●	—	—	—	—	●	—	—	—	—	—	—	—	—	—	—	—	—	—	
Panasonic Corporation	MINAS A5	MSM□/MHMD	—	●	—	—	—	—	—	—	—	—	—	—	—	—	—	—	—	—	—	
		MSMF	—	●	—	—	—	—	—	—	—	—	—	—	—	—	—	—	—	—	—	
	MINAS A6	MHMF	●	—	—	—	—	—	—	—	—	—	●	—	—	—	—	—	—	—	—	
FANUC CORPORATION	βis (-B)	β	●	—	—	—	—	—	—	—	—	—	● (β1 only)	—	—	●	—	—	—	—	—	
NIDEC SANKYO CORPORATION	S-FLAG	MA/MH/MM	●	—	—	—	—	—	—	—	—	—	●	—	—	—	—	—	—	—	—	
KEYENCE CORPORATION	SV	SV-M/SV-B	●	—	—	—	—	—	—	—	—	—	●	—	—	—	—	—	—	—	—	
	SV2	SV2-M/SV2-B	●	—	—	—	—	—	—	—	—	—	●	—	—	—	—	—	—	—	—	
FUJI ELECTRIC CO., LTD.	ALPHA5	GYS/GYB	●	—	—	—	—	—	—	—	—	—	●	—	—	—	—	—	—	—	—	
	ALPHA7	GYS/GYB	●	—	—	—	—	—	—	—	—	—	●	—	—	—	—	—	—	—	—	
	FALDIC α	GYS	●	—	—	—	—	—	—	—	—	—	●	—	—	—	—	—	—	—	—	
MinebeaMitsumi Inc.	SZ	A17PM/A23KM	—	—	—	—	—	●	—	—	—	—	—	—	—	—	—	—	—	●	—	
Shinano Kenshi Co., Ltd.	CSB-BZ	CSB-BZ	—	—	—	—	—	—	—	●	—	—	—	—	—	—	—	—	—	—	—	
ORIENTAL MOTOR Co., Ltd.	AR/AZ	AR/AZ (46 only)	—	—	—	—	—	—	—	—	—	—	—	—	—	—	—	—	—	—	—	
FASTECH Co., Ltd.	Ezi-SERVO	EzM	—	—	—	—	—	—	—	—	—	—	—	—	—	—	—	—	—	—	●	—
		MP-/VP-	MP/VP	—	—	—	—	—	—	—	—	—	—	—	—	—	—	—	—	—	—	—
Rockwell Automation, Inc. (Allen-Bradley)	TL	TLY-A	●	—	—	—	—	—	—	—	—	—	—	—	—	—	—	—	—	—	—	
	AM	AM30	●	—	—	—	—	—	—	—	—	—	—	—	—	—	—	—	—	—	—	
	AM	AM31	●	—	—	—	—	—	—	—	—	—	—	—	—	—	—	—	—	—	—	
Beckhoff Automation GmbH	AM	AM80/AM81	●	—	—	—	—	—	—	—	—	—	—	—	—	—	—	—	—	—	—	
	AM	AM80/AM81	●	—	—	—	—	—	—	—	—	—	—	—	—	—	—	—	—	—	—	
Siemens AG	1FK7	1FK7	—	—	—	—	—	—	—	—	—	—	—	—	—	—	—	—	—	—	—	
Delta Electronics, Inc.	ASDA-A2	ECMA	●	—	—	—	—	—	—	—	—	—	—	—	—	—	—	—	—	—	—	
ANCA Motion	AMD2000	Alpha	●	—	—	—	—	—	—	—	—	—	—	—	—	—	—	—	—	—	—	

Specifications^{*2}

- Values in this specifications table are the allowable values of the actuator body with the standard motor mounted.
- Do not use the actuator so that it exceeds these values.

Model		LEFB25	LEFB32	LEFB40	
Actuator specifications	Stroke [mm] ^{*1}	300, 400, 500 600, 700, 800 900, 1000, (1100) 1200, (1300, 1400) 1500, (1600, 1700) (1800, 1900), 2000	300, 400, 500 600, 700, 800 900, 1000, (1100) 1200, (1300, 1400) 1500, (1600, 1700) (1800, 1900), 2000 2500	300, 400, 500 600, 700, 800 900, 1000, (1100) 1200, (1300, 1400) 1500, (1600, 1700) (1800, 1900), 2000 2500, 3000	
	Work load [kg]	Horizontal	5	15	25
	Speed [mm/s]		2000		
	Pushing return to origin speed [mm/s]		30 or less		
	Positioning repeatability [mm]		±0.06		
	Lost motion [mm] ^{*3}		0.1 or less		
	Equivalent lead [mm]		54		
	Max. acceleration/deceleration [mm/s ²]		20000 ^{*4}		
	Impact/Vibration resistance [m/s ²]		50/20		
	Actuation type		Belt		
	Guide type		Linear guide		
	Operating temperature range [°C]		5 to 40		
	Operating humidity range [%RH]		90 or less (No condensation)		
Other specifications ^{*5}	Actuation unit weight [kg]	0.2	0.3	0.55	
	Other inertia [kg·cm ²]	0.1	0.2	0.25	
	Friction coefficient		0.05		
	Mechanical efficiency		0.8		
Reference motor specifications ^{*6}	Motor shape	□40	□60		
	Motor type	AC servo motor (100 V/200 V)			
	Rated output capacity [W]	100	200	400	
	Rated torque [N·m]	0.32	0.64	1.3	

- *1 Please consult with SMC as all non-standard and non-made-to-order strokes are produced as special orders.
- *2 Do not allow collisions at either end of the table traveling distance at a speed exceeding "pushing return to origin speed." Additionally, when running the positioning operation, do not set within 3 mm of both ends.
- *3 A reference value for correcting an error in reciprocal operation
- *4 Maximum acceleration/deceleration changes according to the work load. Refer to the "Work Load–Acceleration/Deceleration Graph (Guide)" for belt drive on page 847.
- *5 Each value is only to be used as a guide to select a motor of the appropriate capacity.
- *6 For other specifications, refer to the specifications of the motor that is to be installed.

Weight

Model	LEFB25																	
Stroke [mm]	300	400	500	600	700	800	900	1000	1100	1200	1300	1400	1500	1600	1700	1800	1900	2000
Product weight [kg]	2.5	2.75	3	3.25	3.5	3.75	4	4.25	4.5	4.75	5	5.25	5.5	5.75	6	6.25	6.5	6.75

Model	LEFB32																		
Stroke [mm]	300	400	500	600	700	800	900	1000	1100	1200	1300	1400	1500	1600	1700	1800	1900	2000	2500
Product weight [kg]	4.00	4.35	4.70	5.05	5.40	5.75	6.10	6.45	6.80	7.15	7.50	7.85	8.20	8.55	8.90	9.25	9.60	9.95	11.70

Model	LEFB40																			
Stroke [mm]	300	400	500	600	700	800	900	1000	1100	1200	1300	1400	1500	1600	1700	1800	1900	2000	2500	3000
Product weight [kg]	5.72	6.17	6.62	7.07	7.52	7.97	8.42	8.87	9.32	9.77	10.22	10.67	11.12	11.57	12.02	12.47	12.92	13.37	15.82	17.87

LEFS
LEFB

LEJS
LEJB

LEL

LEM

LEY
LEYG

LES
LESH

LEPY
LEPS

LER

LEH

LEY-X5

11-LEFS

11-LEJS

25A-

LEC □

JXC □

LECS □
LECS-T

LECY □

Motorless

LAT3

LEFB Series

Motorless Type

Refer to the “Motor Mounting” on page 865 for details about motor mounting and included parts.

Dimensions: Belt Drive

LEFB25/Motor top mounting type

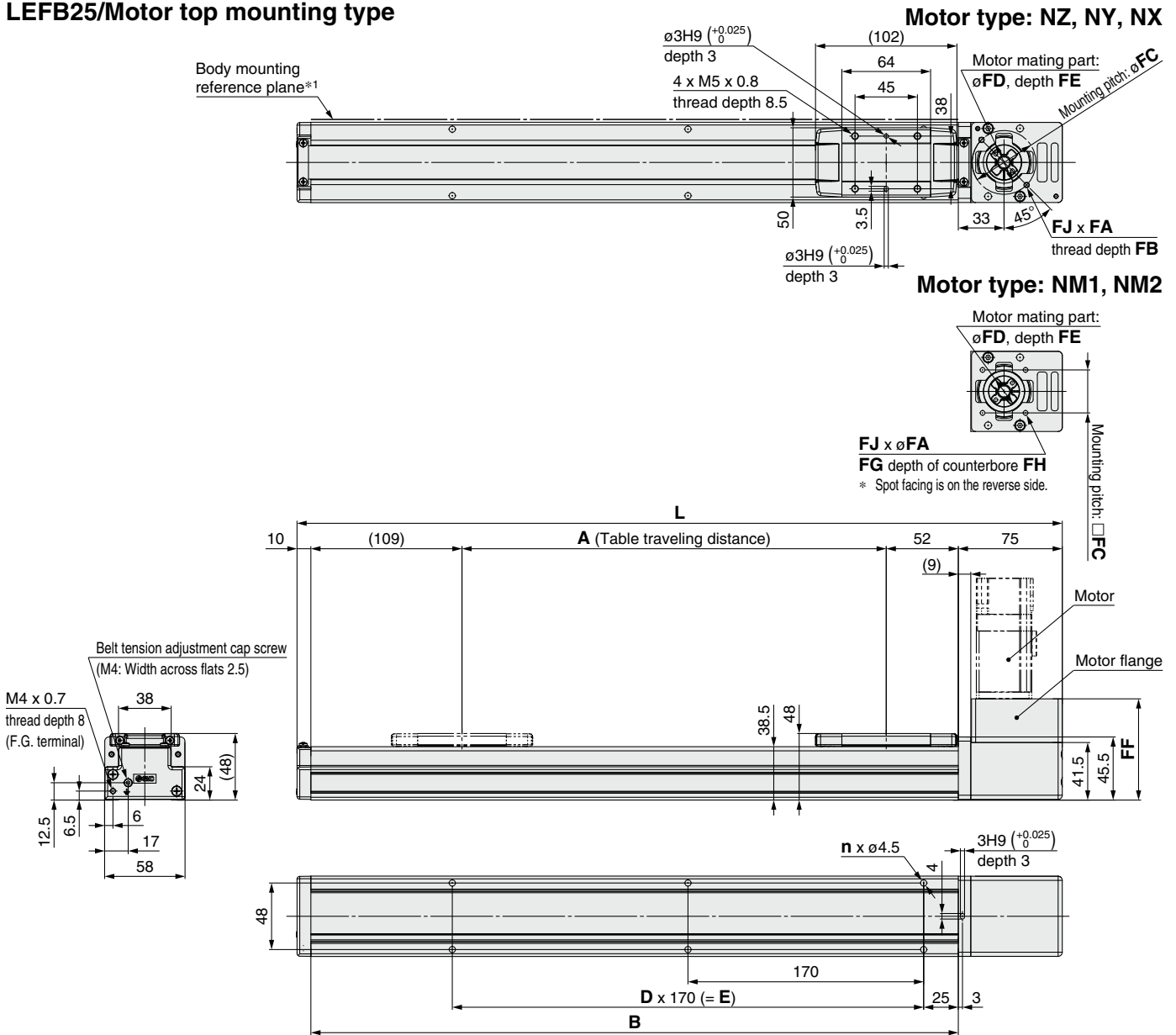

*1 When mounting the actuator using the body mounting reference plane, set the height of the opposite surface or pin to be 3 mm or more. (Recommended height 5 mm)

Dimensions

Stroke	L	A	B	n	D	E
300	552	306	467	6	2	340
400	652	406	567	8	3	510
500	752	506	667	8	3	510
600	852	606	767	10	4	680
700	952	706	867	10	4	680
800	1052	806	967	12	5	850
900	1152	906	1067	14	6	1020
1000	1252	1006	1167	14	6	1020
1100	1352	1106	1267	16	7	1190
1200	1452	1206	1367	16	7	1190
1300	1552	1306	1467	18	8	1360
1400	1652	1406	1567	20	9	1530
1500	1752	1506	1667	20	9	1530
1600	1852	1606	1767	22	10	1700
1700	1952	1706	1867	22	10	1700
1800	2052	1806	1967	24	11	1870
1900	2152	1906	2067	24	11	1870
2000	2252	2006	2167	26	12	2040

Motor Mounting Dimensions

Motor type	FA	FB	FC	FD	FE	FF	FG	FH	FJ
NZ	M4 x 0.7	8	46	30	3.5	73	—	—	2
NY	M3 x 0.5	8	45	30	3.5	73	—	—	4
NX	M4 x 0.7	8	46	30	3.5	73	—	—	2
NM1/NM2	3.4	—	31	22*1	2.5*1	73	6	21	4

*1 Dimensions after mounting a ring spacer (Refer to page 865.)

Refer to the "Motor Mounting" on page 865 for details about motor mounting and included parts.

Dimensions: Belt Drive

LEFB25/Motor top mounting type

Positioning pin hole*1 (Option): Body bottom

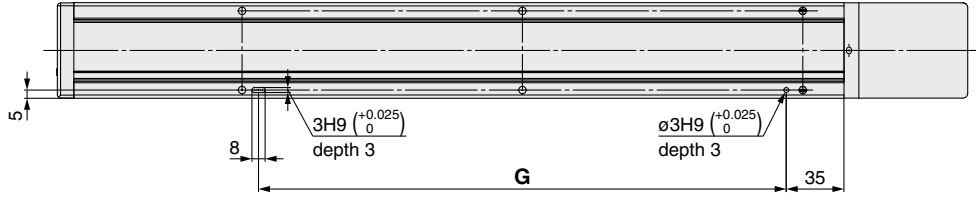

*1 When using the body bottom positioning pin holes, do not simultaneously use the housing B bottom pin hole.

With auto switch (Option)

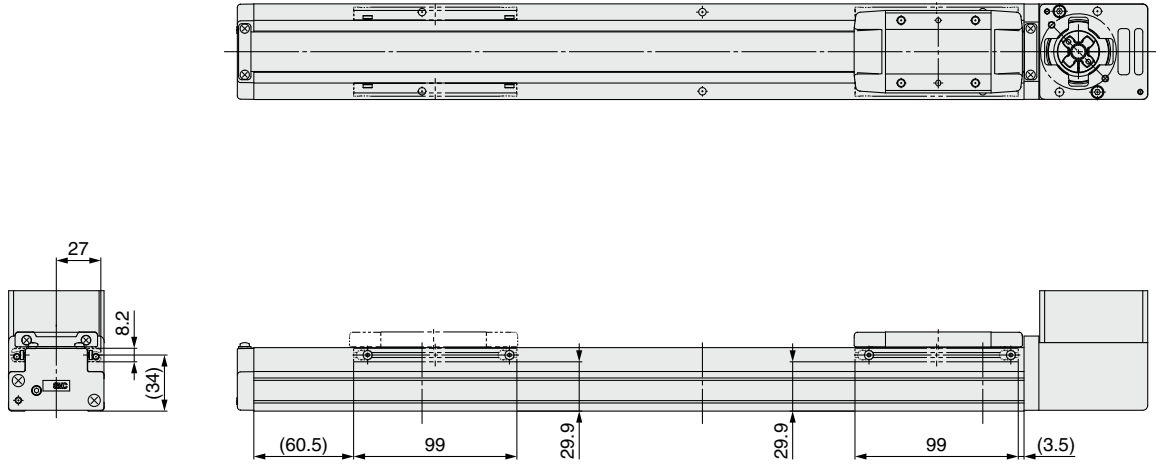

Dimensions [mm]

Stroke	G
300	320
400	490
500	490
600	660
700	660
800	830
900	1000
1000	1000
1100	1170
1200	1170
1300	1340
1400	1510
1500	1510
1600	1680
1700	1680
1800	1850
1900	1850
2000	2020

LEFS
LEFB

LEJS
LEJB

LEL

LEM

LEY
LEYG

LES
LESH

LEPY
LEPS

LER

LEH

LEY-X5

11-LEFS

11-LEJS

25A-

LEC

JXC

LECS
LECS-T

LECY

Motorless

LAT3

LEFB Series

Motorless Type

Refer to the "Motor Mounting" on page 865 for details about motor mounting and included parts.

Dimensions: Belt Drive

LEFB25U/Motor bottom mounting type

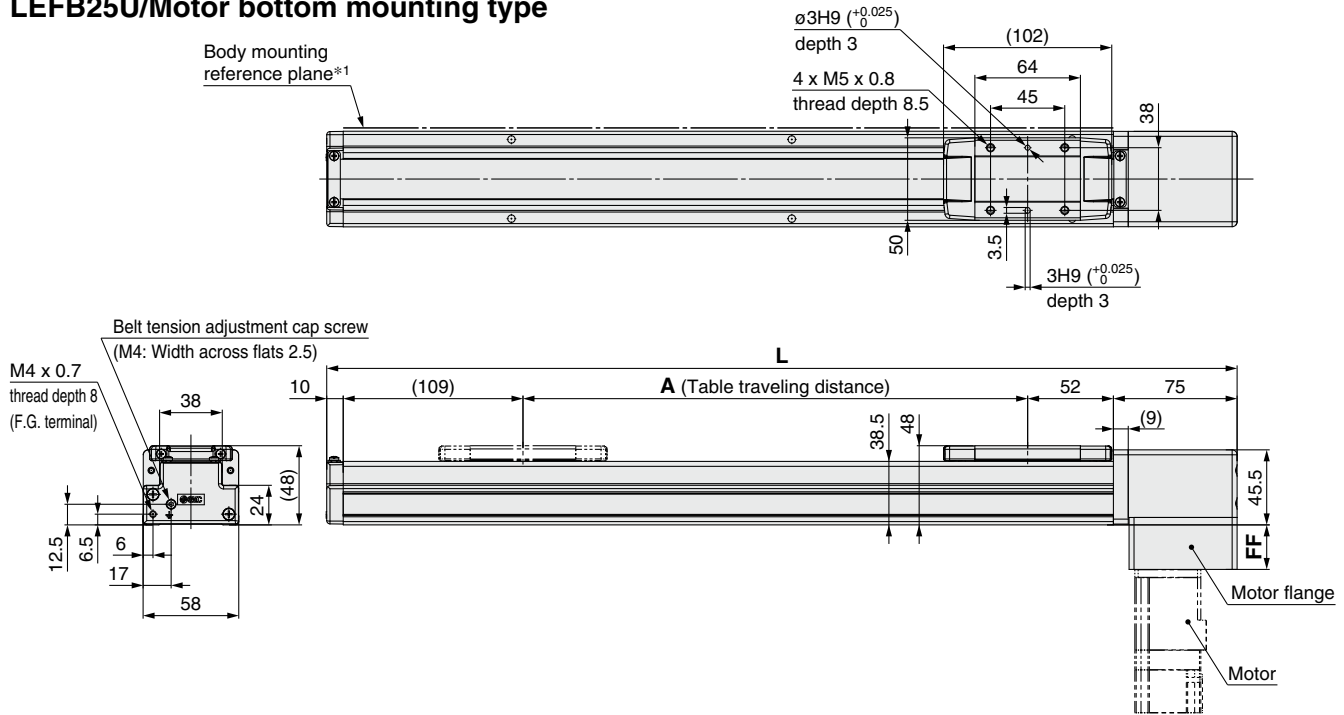

Motor type: NZ, NY, NX

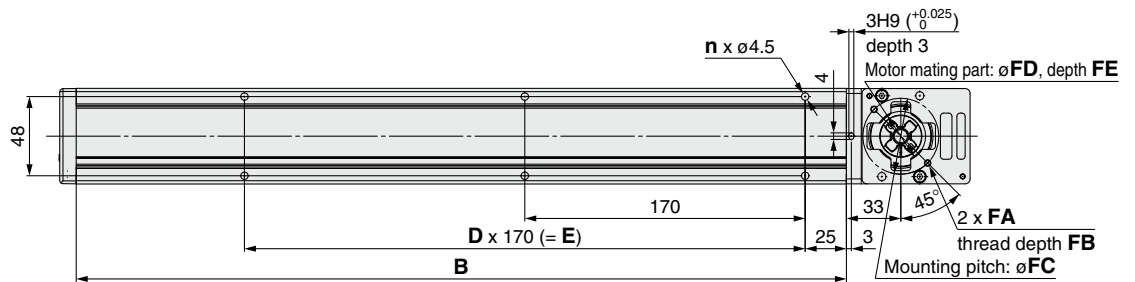

Motor type: NM1, NM2

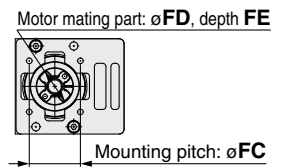

Dimensions

Stroke	L	A	B	n	D	E
300	552	306	467	6	2	340
400	652	406	567	8	3	510
500	752	506	667	8	3	510
600	852	606	767	10	4	680
700	952	706	867	10	4	680
800	1052	806	967	12	5	850
900	1152	906	1067	14	6	1020
1000	1252	1006	1167	14	6	1020
1100	1352	1106	1267	16	7	1190
1200	1452	1206	1367	16	7	1190
1300	1552	1306	1467	18	8	1360
1400	1652	1406	1567	20	9	1530
1500	1752	1506	1667	20	9	1530
1600	1852	1606	1767	22	10	1700
1700	1952	1706	1867	22	10	1700
1800	2052	1806	1967	24	11	1870
1900	2152	1906	2067	24	11	1870
2000	2252	2006	2167	26	12	2040

*1 When mounting the actuator using the body mounting reference plane, set the height of the opposite surface or pin to be 3 mm or more. (Recommended height 5 mm)

Motor Mounting Dimensions

Motor type	FA	FB	FC	FD	FE	FF	FG	FH	FJ
NZ	M4 x 0.7	8	46	30	3.5	27	—	—	2
NY	M3 x 0.5	8	45	30	3.5	27	—	—	4
NX	M4 x 0.7	8	46	30	3.5	27	—	—	2
NM1/NM2	3.4	—	31	22*1	2.5*1	27	6	21	4

*1 Dimensions after mounting a ring spacer (Refer to page 865.)

Refer to the "Motor Mounting" on page 865 for details about motor mounting and included parts.

Dimensions: Belt Drive

LEFB25U/Motor bottom mounting type

Positioning pin hole*1 (Option): Body bottom

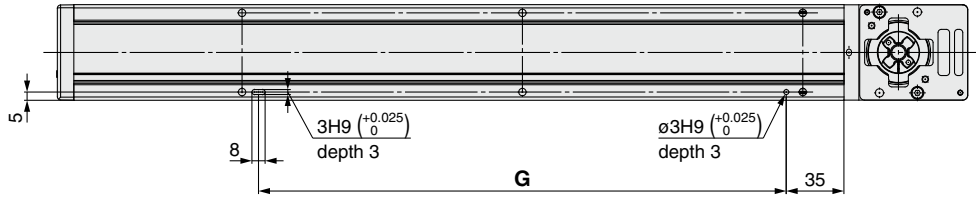

*1 When using the body bottom positioning pin holes, do not simultaneously use the housing B bottom pin hole.

With auto switch (Option)

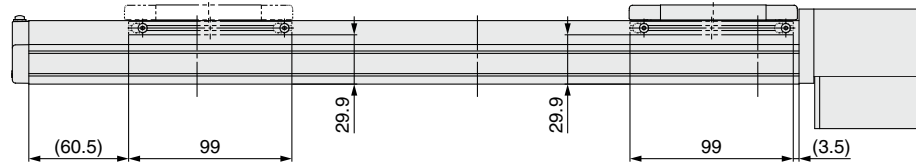
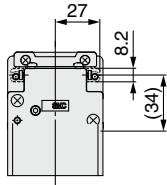
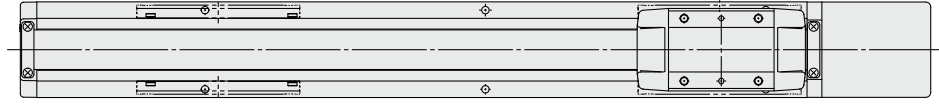

Dimensions [mm]

Stroke	G
300	320
400	490
500	490
600	660
700	660
800	830
900	1000
1000	1000
1100	1170
1200	1170
1300	1340
1400	1510
1500	1510
1600	1680
1700	1680
1800	1850
1900	1850
2000	2020

LEFS
LEFB

LEJS
LEJB

LEL

LEM

LEY
LEYG

LES
LESH

LEPY
LEPS

LER

LEH

LEY-X5

11-LEFS

11-LEJS

25A-

LEC

JXC

LECS
LECS-T

LECY

Motorless

LAT3

LEFB Series

Motorless Type

Refer to the "Motor Mounting" on page 865 for details about motor mounting and included parts.

Dimensions: Belt Drive

LEFB32/Motor top mounting type

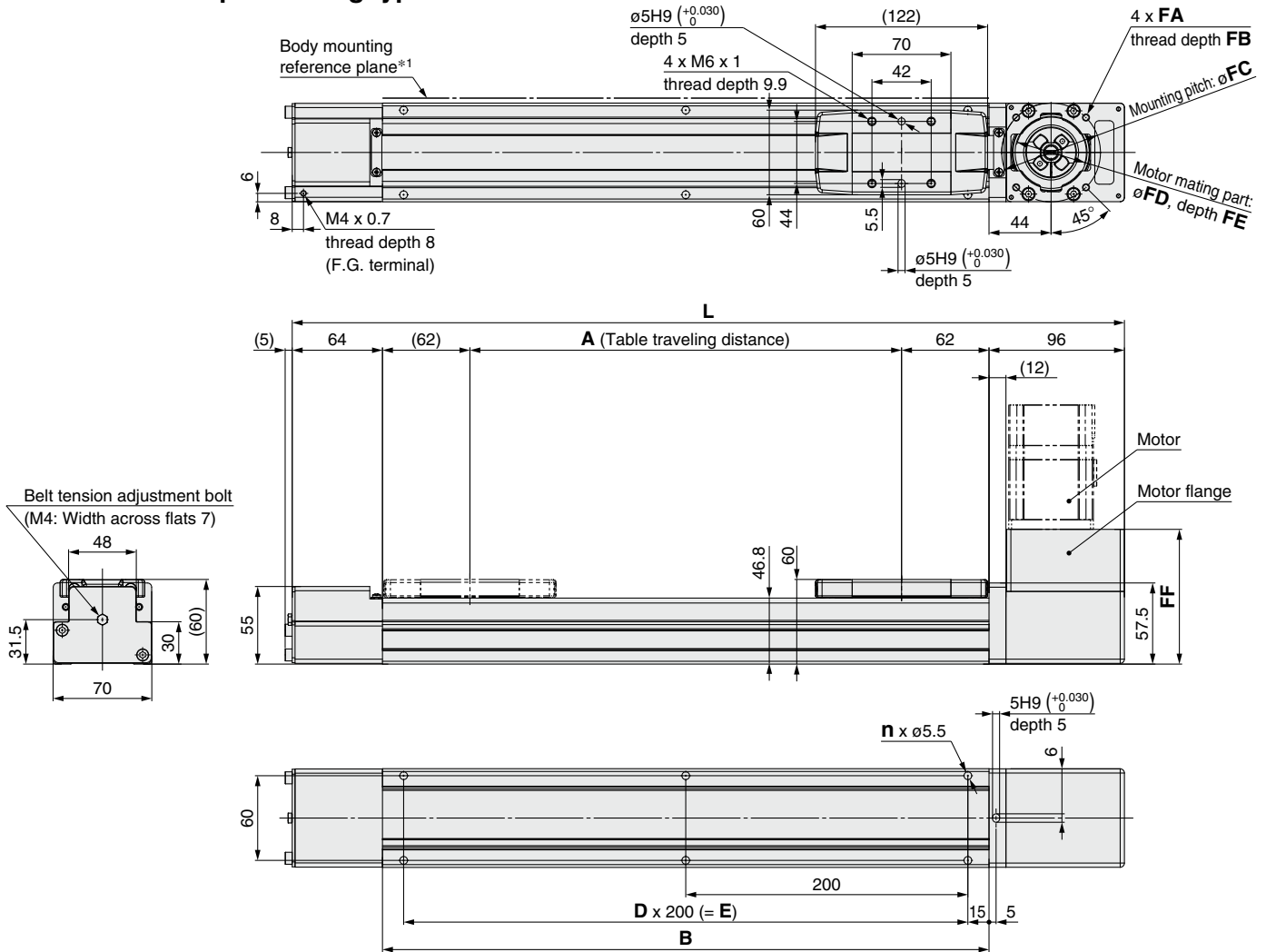

*1 When mounting the actuator using the body mounting reference plane, set the height of the opposite surface or pin to be 3 mm or more. (Recommended height 5 mm)

Dimensions

Stroke	L	A	B	n	D	E
300	590	306	430	6	2	400
400	690	406	530	6	2	400
500	790	506	630	8	3	600
600	890	606	730	8	3	600
700	990	706	830	10	4	800
800	1090	806	930	10	4	800
900	1190	906	1030	12	5	1000
1000	1290	1006	1130	12	5	1000
1100	1390	1106	1230	14	6	1200
1200	1490	1206	1330	14	6	1200
1300	1590	1306	1430	16	7	1400
1400	1690	1406	1530	16	7	1400
1500	1790	1506	1630	18	8	1600
1600	1890	1606	1730	18	8	1600
1700	1990	1706	1830	20	9	1800
1800	2090	1806	1930	20	9	1800
1900	2190	1906	2030	22	10	2000
2000	2290	2006	2130	22	10	2000
2500	2790	2506	2630	28	13	2600

Motor Mounting Dimensions

Motor type	FA	FB	FC	FD	FE	FF
NZ	M5 x 0.8	9	70	50	4	95.5
NY	M4 x 0.7	8	70	50	4	95.5
NX	M5 x 0.8	9	63	40*1	4.5*1	99.2
NW	M5 x 0.8	9	70	50	5	96.5
NV	M4 x 0.7	8	63	40*1	4.5*1	99.2
NU	M5 x 0.8	9	70	50	5	96.5
NT	M5 x 0.8	9	70	50	4	95.5
NM1	M4 x 0.7	8	□47.14	38.1*1	4.5*1	82.5
NM2	M4 x 0.7	8	□50	36*1	4.5*1	90.0

*1 Dimensions after mounting a ring spacer (Refer to page 865.)

Refer to the "Motor Mounting" on page 865 for details about motor mounting and included parts.

Dimensions: Belt Drive

LEFB32/Motor top mounting type

Positioning pin hole*1 (Option): Body bottom

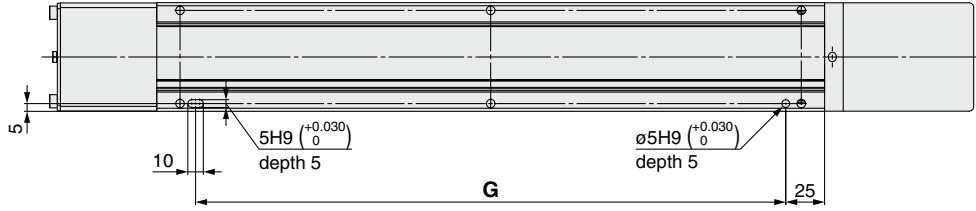

*1 When using the body bottom positioning pin holes, do not simultaneously use the housing B bottom pin hole.

With auto switch (Option)

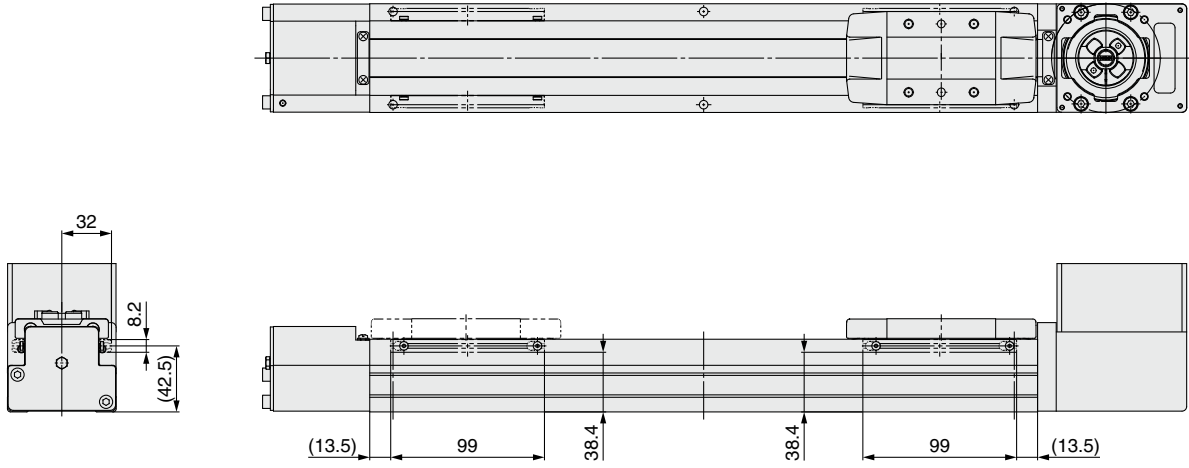

Dimensions [mm]

Stroke	G
300	380
400	380
500	580
600	580
700	780
800	780
900	980
1000	980
1100	1180
1200	1180
1300	1380
1400	1380
1500	1580
1600	1580
1700	1780
1800	1780
1900	1980
2000	1980
2500	2580

LEFS
LEFB

LEJS
LEJB

LEL

LEM

LEY
LEYG

LES
LESH

LEPY
LEPS

LER

LEH

LEY-X5

11-LEFS

11-LEJS

25A-

LEC

JXC

LECS
LECS-T

LECY

Motorless

LAT3

LEFB Series

Motorless Type

Refer to the "Motor Mounting" on page 865 for details about motor mounting and included parts.

Dimensions: Belt Drive

LEFB32U/Motor bottom mounting type

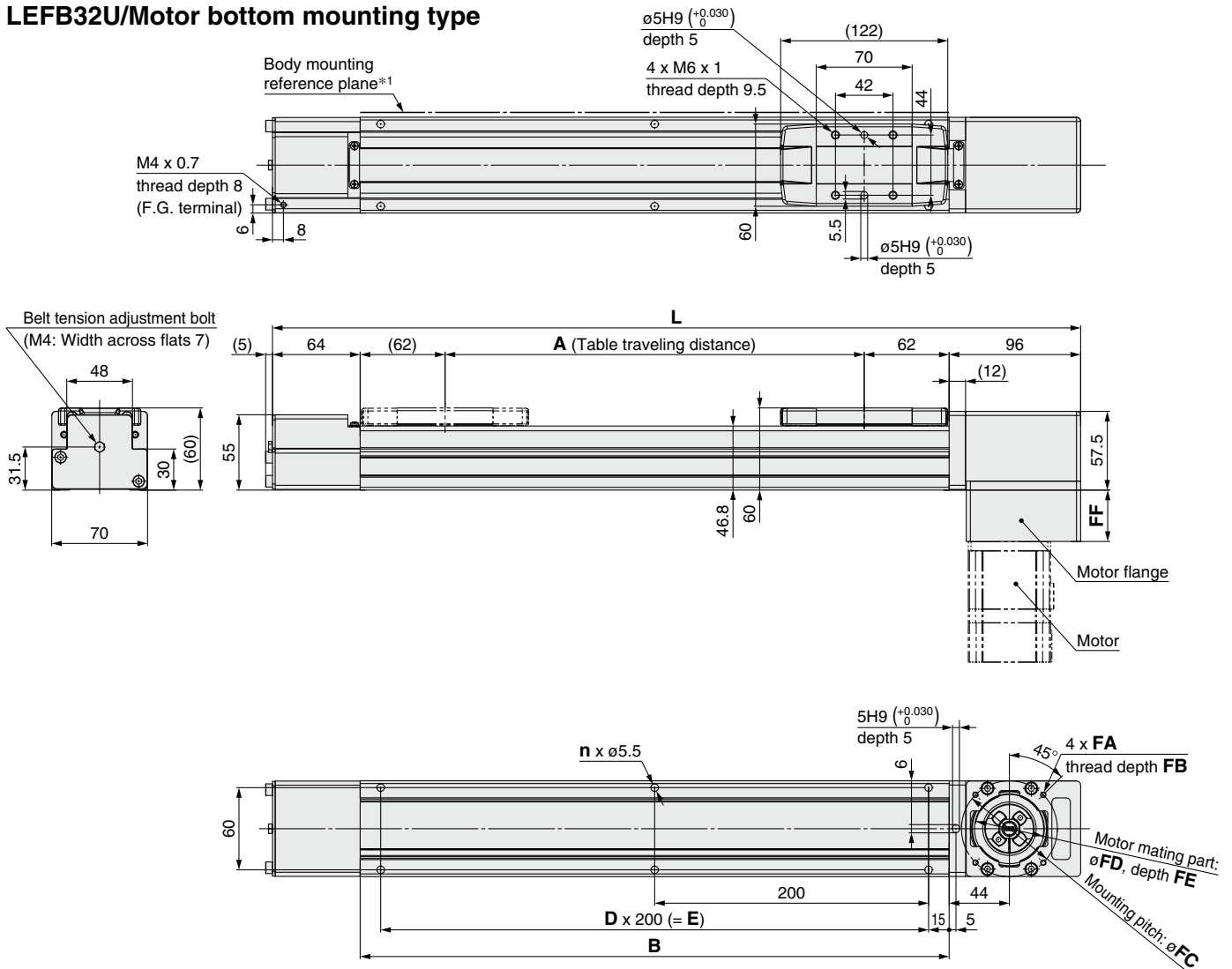

*1 When mounting the actuator using the body mounting reference plane, set the height of the opposite surface or pin to be 3 mm or more. (Recommended height 5 mm)

Dimensions

Stroke	L	A	B	n	D	E
300	590	306	430	6	2	400
400	690	406	530	6	2	400
500	790	506	630	8	3	600
600	890	606	730	8	3	600
700	990	706	830	10	4	800
800	1090	806	930	10	4	800
900	1190	906	1030	12	5	1000
1000	1290	1006	1130	12	5	1000
1100	1390	1106	1230	14	6	1200
1200	1490	1206	1330	14	6	1200
1300	1590	1306	1430	16	7	1400
1400	1690	1406	1530	16	7	1400
1500	1790	1506	1630	18	8	1600
1600	1890	1606	1730	18	8	1600
1700	1990	1706	1830	20	9	1800
1800	2090	1806	1930	20	9	1800
1900	2190	1906	2030	22	10	2000
2000	2290	2006	2130	22	10	2000
2500	2790	2506	2630	28	13	2600

Motor Mounting Dimensions

Motor type	FA	FB	FC	FD	FE	FF
NZ	M5 x 0.8	9	70	50	4	37.5
NY	M4 x 0.7	8	70	50	4	37.5
NX	M5 x 0.8	9	63	40*1	4.5*1	41.2
NW	M5 x 0.8	9	70	50	5	38.5
NV	M4 x 0.7	8	63	40*1	4.5*1	41.2
NU	M5 x 0.8	9	70	50	5	38.5
NT	M5 x 0.8	9	70	50	4	37.5
NM1	M4 x 0.7	8	□47.14	38.1*1	4.5*1	24.5
NM2	M4 x 0.7	8	□50	36*1	4.5*1	32

*1 Dimensions after mounting a ring spacer (Refer to page 865.)

Refer to the "Motor Mounting" on page 865 for details about motor mounting and included parts.

Dimensions: Belt Drive

LEFB32U/Motor bottom mounting type

Positioning pin hole*1 (Option): Body bottom

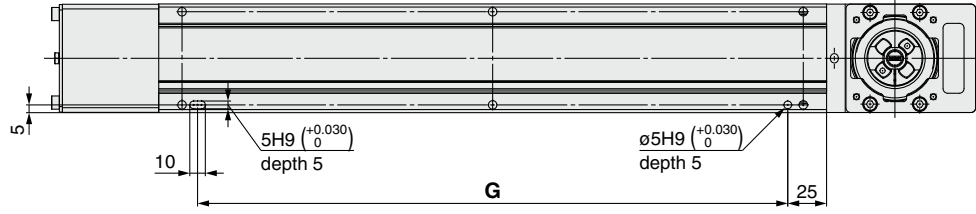

*1 When using the body bottom positioning pin holes, do not simultaneously use the housing B bottom pin hole.

With auto switch (Option)

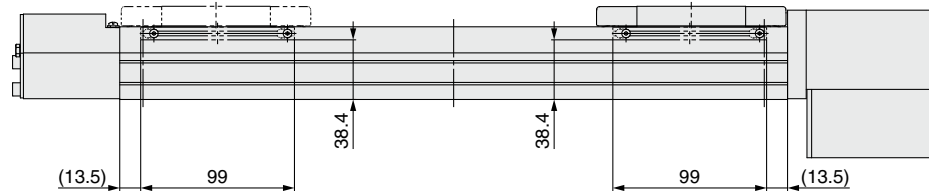
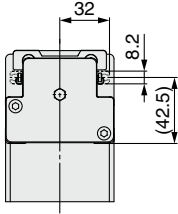
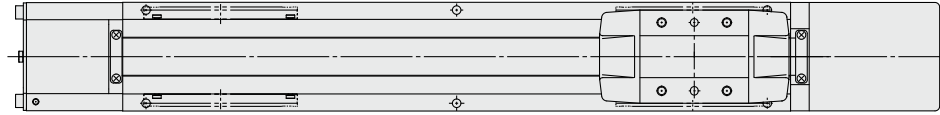

Dimensions [mm]

Stroke	G
300	380
400	380
500	580
600	580
700	780
800	780
900	980
1000	980
1100	1180
1200	1180
1300	1380
1400	1380
1500	1580
1600	1580
1700	1780
1800	1780
1900	1980
2000	1980
2500	2580

LEFS
LEFB

LEJS
LEJB

LEL

LEM

LEY
LEYG

LES
LESH

LEPY
LEPS

LER

LEH

LEY-X5

11-LEFS

11-LEJS

25A-

LEC

JXC

LECS
LECS-T

LECY

Motorless

LAT3

LEFB Series

Motorless Type

Refer to the "Motor Mounting" on page 865 for details about motor mounting and included parts.

Dimensions: Belt Drive

LEFB40/Motor top mounting type

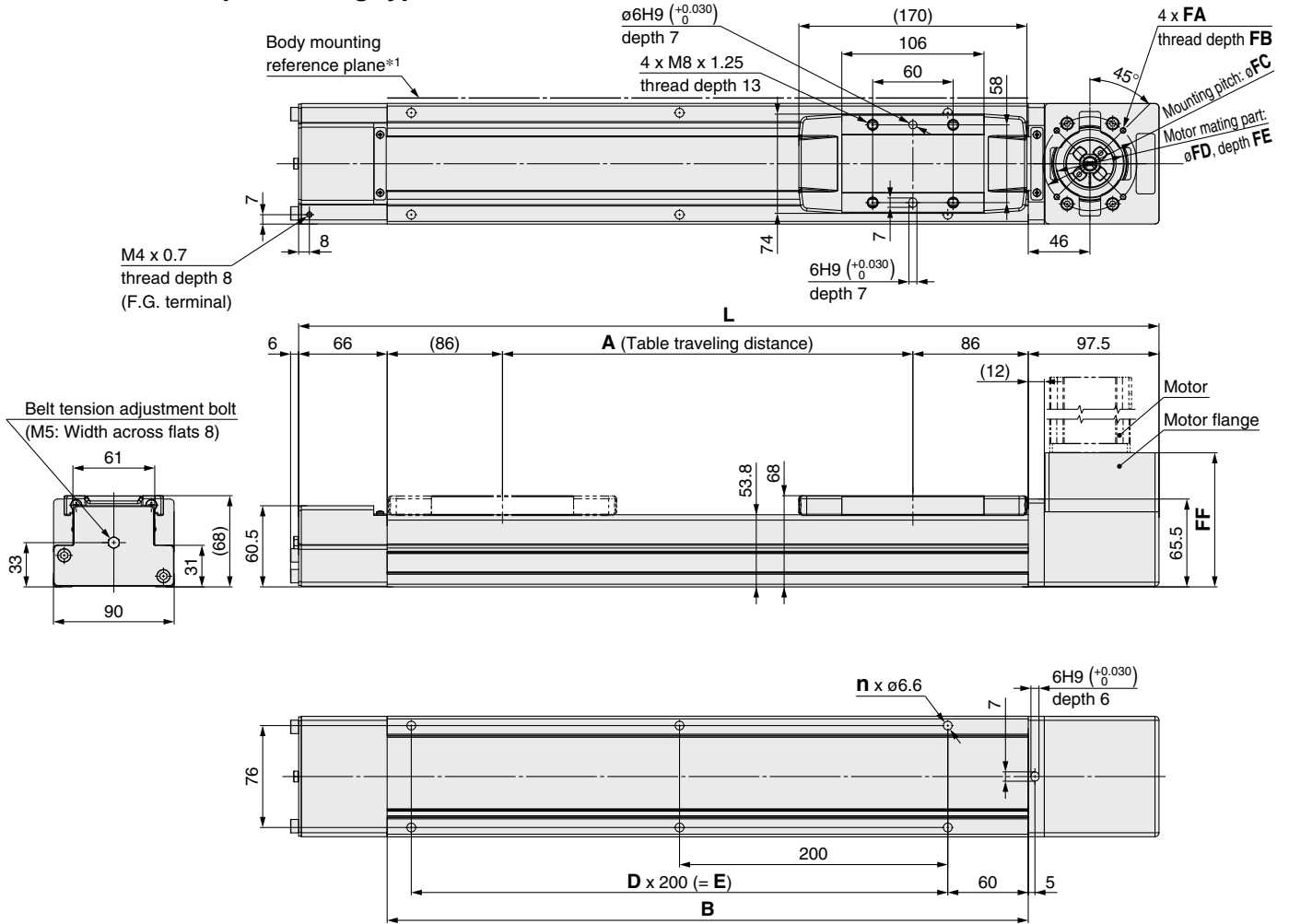

*1 When mounting the actuator using the body mounting reference plane, set the height of the opposite surface or pin to be 3 mm or more. (Recommended height 5 mm)

Dimensions

[mm]

Stroke	L	A	B	n	D	E
300	641.5	306	478	6	2	400
400	741.5	406	578	6	2	400
500	841.5	506	678	8	3	600
600	941.5	606	778	8	3	600
700	1041.5	706	878	10	4	800
800	1141.5	806	978	10	4	800
900	1241.5	906	1078	12	5	1000
1000	1341.5	1006	1178	12	5	1000
1100	1441.5	1106	1278	14	6	1200
1200	1541.5	1206	1378	14	6	1200
1300	1641.5	1306	1478	16	7	1400
1400	1741.5	1406	1578	16	7	1400
1500	1841.5	1506	1678	18	8	1600
1600	1941.5	1606	1778	18	8	1600
1700	2041.5	1706	1878	20	9	1800
1800	2141.5	1806	1978	20	9	1800
1900	2241.5	1906	2078	22	10	2000
2000	2341.5	2006	2178	22	10	2000
2500	2841.5	2506	2678	28	13	2600
3000	3341.5	3006	3178	32	15	3000

Motor Mounting Dimensions

[mm]

Motor type	FA	FB	FC	FD	FE	FF
NZ	M5 x 0.8	9	70	50	4	100
NY	M4 x 0.7	8	70	50	4	100
NX	M5 x 0.8	9	63	40*1	4.5*1	103.2
NW	M5 x 0.8	9	70	50	5	101
NV	M4 x 0.7	8	63	40	4.5*1	103.2
NU	M5 x 0.8	9	70	50	5	101
NT	M5 x 0.8	9	70	50	4	100
NM1	M4 x 0.7	8	□47.14	38.1*1	4.5*1	87
NM2	M4 x 0.7	8	□50	36*1	4.5*1	94

*1 Dimensions after mounting a ring spacer (Refer to page 865.)

Refer to the "Motor Mounting" on page 865 for details about motor mounting and included parts.

Dimensions: Belt Drive

LEFB40/Motor top mounting type

Positioning pin hole*1 (Option): Body bottom

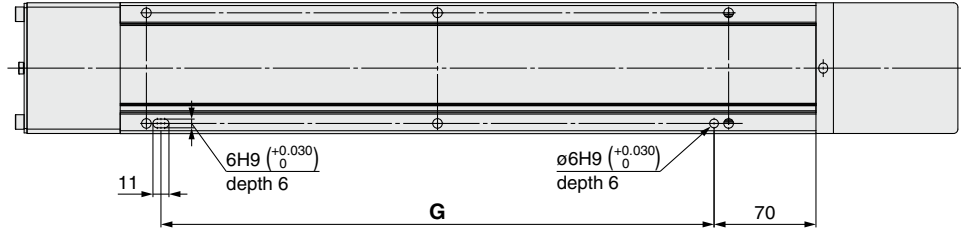

*1 When using the body bottom positioning pin holes, do not simultaneously use the housing B bottom pin hole.

With auto switch (Option)

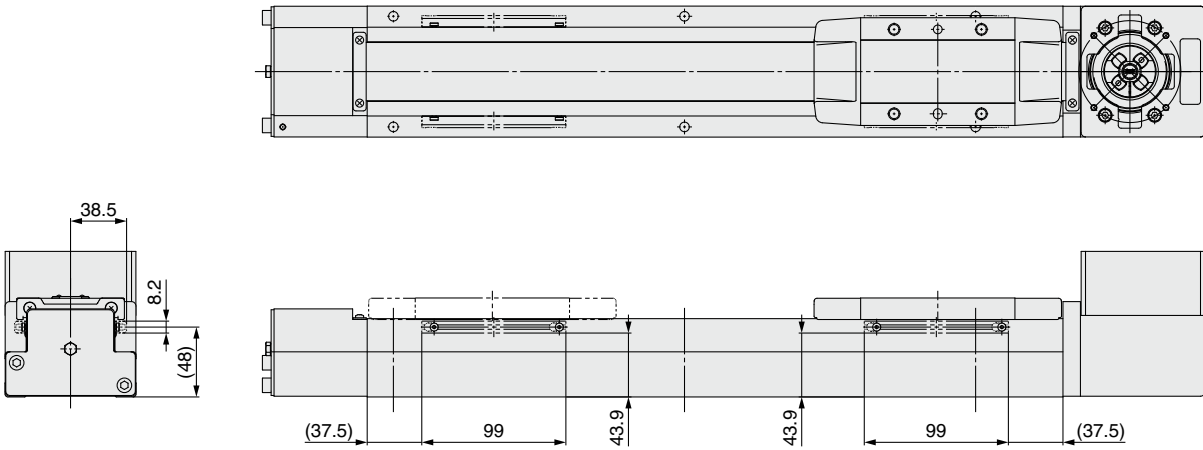

Dimensions [mm]

Stroke	G
300	380
400	380
500	580
600	580
700	780
800	780
900	980
1000	980
1100	1180
1200	1180
1300	1380
1400	1380
1500	1580
1600	1580
1700	1780
1800	1780
1900	1980
2000	1980
2500	2580
3000	2980

LEFS
LEFB

LEJS
LEJB

LEL

LEM

LEY
LEYG

LES
LESH

LEPY
LEPS

LER

LEH

LEY-X5

11-LEFS

11-LEJS

25A-

LEC

JXC

LECS
LECS-T

LECY

Motorless

LAT3

LEFB Series

Motorless Type

Refer to the "Motor Mounting" on page 865 for details about motor mounting and included parts.

Dimensions: Belt Drive

LEFB40U/Motor bottom mounting type

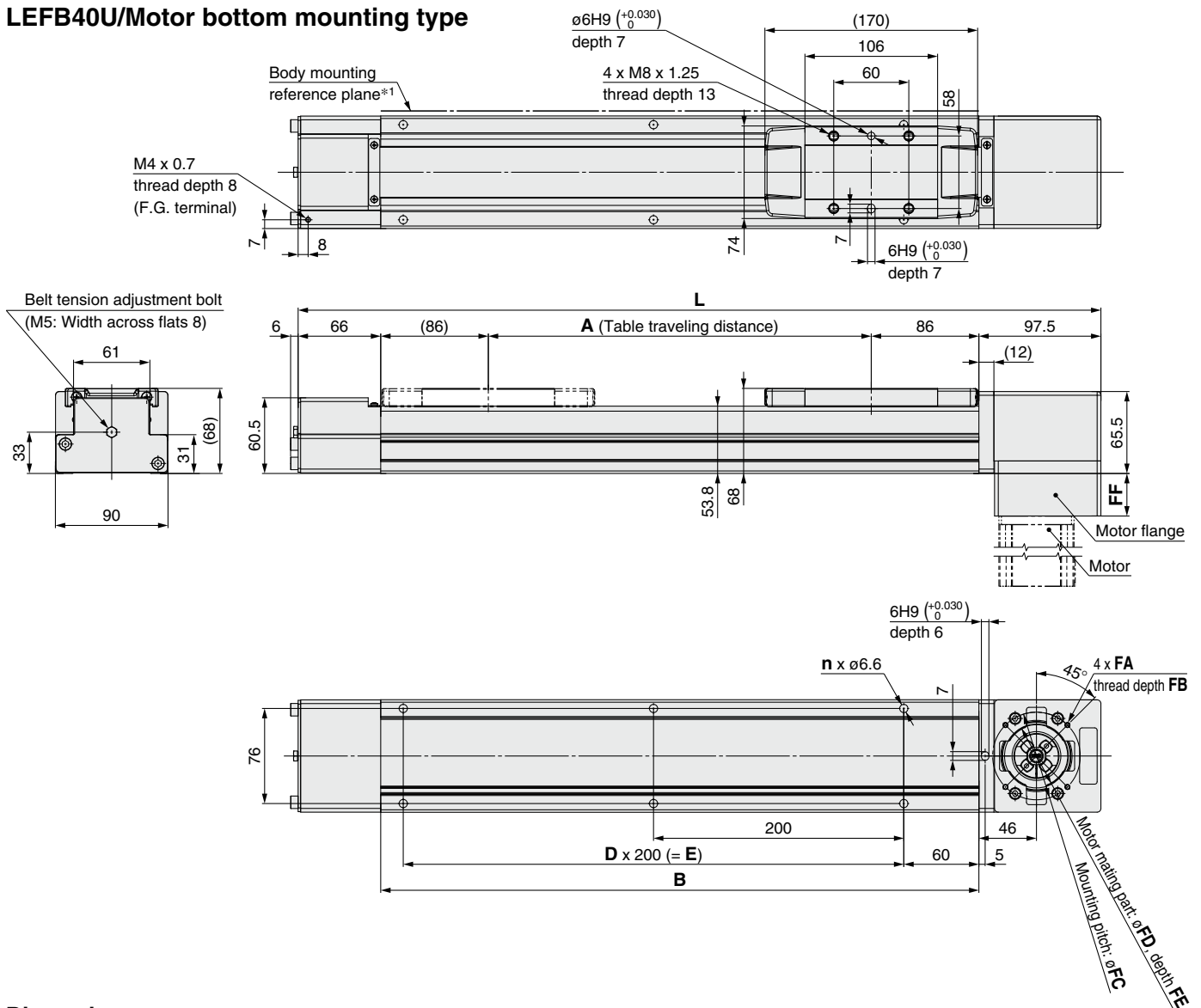

Dimensions

[mm]

Stroke	L	A	B	n	D	E
300	641.5	306	478	6	2	400
400	741.5	406	578	6	2	400
500	841.5	506	678	8	3	600
600	941.5	606	778	8	3	600
700	1041.5	706	878	10	4	800
800	1141.5	806	978	10	4	800
900	1241.5	906	1078	12	5	1000
1000	1341.5	1006	1178	12	5	1000
1100	1441.5	1106	1278	14	6	1200
1200	1541.5	1206	1378	14	6	1200
1300	1641.5	1306	1478	16	7	1400
1400	1741.5	1406	1578	16	7	1400
1500	1841.5	1506	1678	18	8	1600
1600	1941.5	1606	1778	18	8	1600
1700	2041.5	1706	1878	20	9	1800
1800	2141.5	1806	1978	20	9	1800
1900	2241.5	1906	2078	22	10	2000
2000	2341.5	2006	2178	22	10	2000
2500	2841.5	2506	2678	28	13	2600
3000	3341.5	3006	3178	32	15	3000

*1 When mounting the actuator using the body mounting reference plane, set the height of the opposite surface or pin to be 3 mm or more. (Recommended height 5 mm)

Motor Mounting Dimensions

[mm]

Motor type	FA	FB	FC	FD	FE	FF
NZ	M5 x 0.8	9	70	50	4	34
NY	M4 x 0.7	8	70	50	4	34
NX	M5 x 0.8	9	63	40*1	4.5*1	37.2
NW	M5 x 0.8	9	70	50	5	35
NV	M4 x 0.7	8	63	40*1	4.5*1	37.2
NU	M5 x 0.8	9	70	50	5	35
NT	M5 x 0.8	9	70	50	4	34
NM1	M4 x 0.7	8	□47.14	38.1*1	4.5*1	21
NM2	M4 x 0.7	8	□50	36*1	4.5*1	28

*1 Dimensions after mounting a ring spacer (Refer to page 865.)

Refer to the "Motor Mounting" on page 865 for details about motor mounting and included parts.

Dimensions: Belt Drive

LEFB40U/Motor bottom mounting type

Positioning pin hole *1 (Option): Body bottom

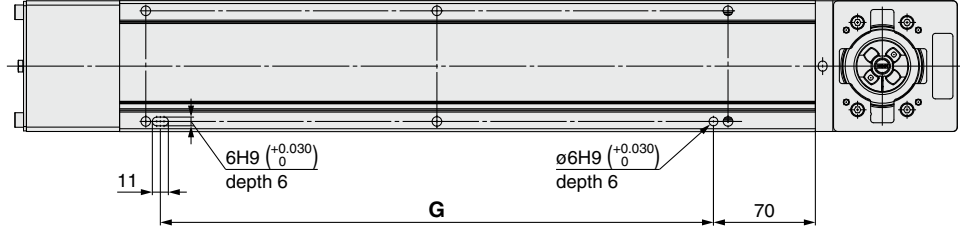

*1 When using the body bottom positioning pin holes, do not simultaneously use the housing B bottom pin hole.

With auto switch (Option)

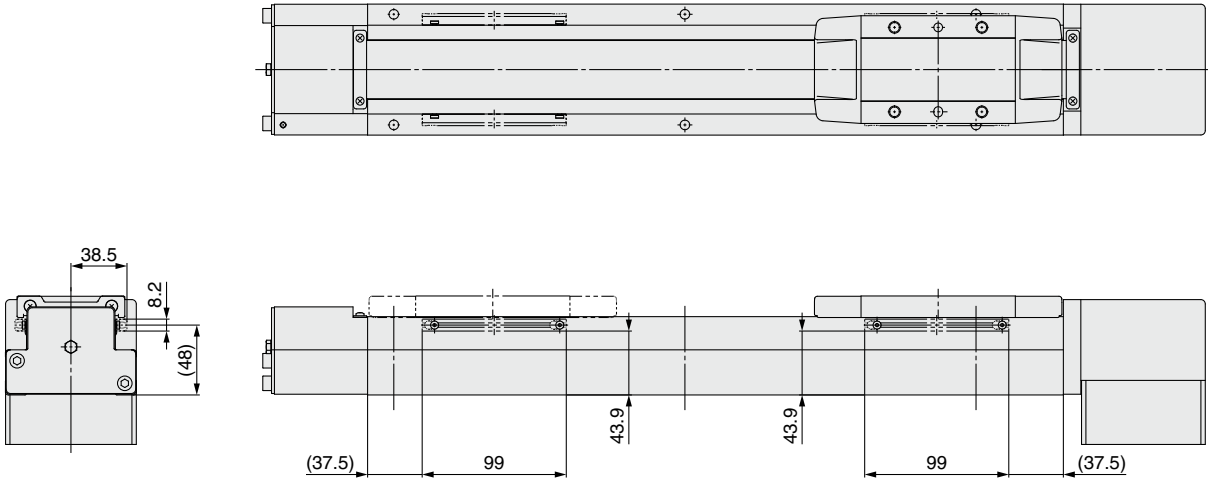

Dimensions [mm]

Stroke	G
300	380
400	380
500	580
600	580
700	780
800	780
900	980
1000	980
1100	1180
1200	1180
1300	1380
1400	1380
1500	1580
1600	1580
1700	1780
1800	1780
1900	1980
2000	1980
2500	2580
3000	2980

- LEFS
LEFB
- LEJS
LEJB
- LEL
- LEM
- LEY
LEYG
- LES
LESH
- LEPY
LEPS
- LER
- LEH
- LEY-X5
- 11-LEFS
- 11-LEJS
- 25A-
- LEC
- JXC
- LECS
LECS-T
- LECY
- Motorless
- LAT3

LEFB Series

Motorless Type

- When mounting a hub, remove all oil content, dust, and dirt adhered to the shaft and the inside of the hub.
- This product does not include the motor and motor mounting screws. (Provided by the customer)
- Prepare a motor with a round shaft end.
For the "NM1," prepare a D-cut shaft.
- Take measures to prevent the loosening of the motor mounting screws and hexagon socket head set screws.

Motor Mounting

Motor type: NZ, NY, NX, NW, NV, NU, NT, NM2

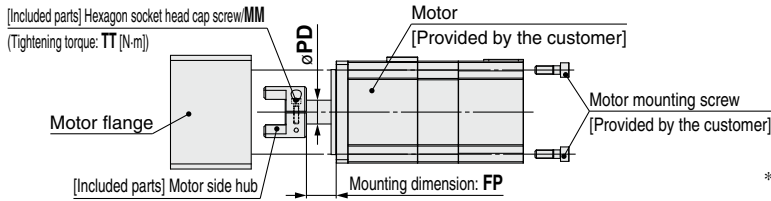

* Note for mounting a motor to the NM2 motor type
Motor mounting screws for the LEFB25 are fixed starting from the motor flange side. (Opposite of the drawing)

Motor type: NM1

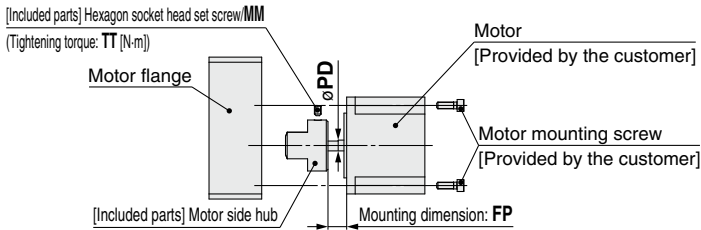

* Note for mounting a hub to the NM1 motor type
When mounting the hub to the motor, make sure to position the set screw vertical to the D-cut surface of the motor shaft. (Refer to the figure shown below)

* Motor mounting screws for the LEFB25 are fixed starting from the motor flange side. (Opposite of the drawing)

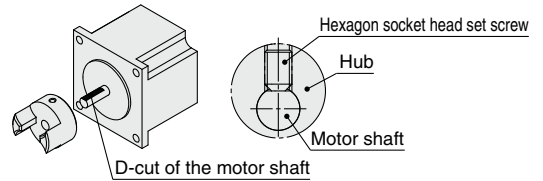

Motor Mounting Diagram

Motor type: NZ, NY, NW, NU, NT

Mounting procedure

- 1) Secure the motor hub to the motor (provided by the customer) with the MM hexagon socket head cap screw.
- 2) Check the motor hub position, and then insert it. (Refer to the mounting diagram.)
- 3) Secure the motor to the motor flange with the motor mounting screws (provided by the customer).

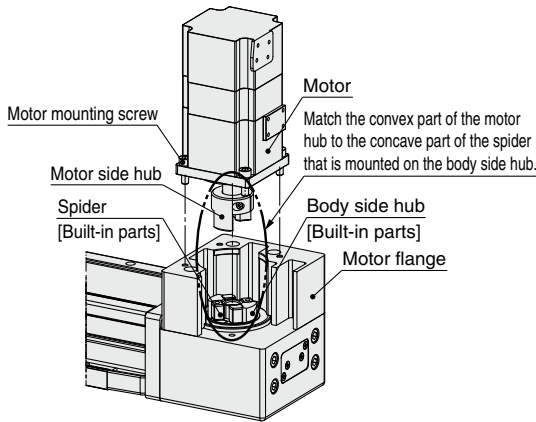

Motor type: NX, NV, NM1, NM2

Mounting procedure

- 1) Secure the motor hub to the motor (provided by the customer) with the MM hexagon socket head cap screw (Motor type: NX, NM2) or MM hexagon socket head set screw (Motor type: NM1).
- 2) Check the motor hub position, and then insert it. (Refer to the mounting diagram.)
- 3) Mount the ring spacer to the motor.
- 4) Secure the motor to the motor flange with the motor mounting screws (provided by the customer).
- * For the LEFB25
- 4) Remove the motor flange, which has been temporarily mounted, from the housing B, and secure the motor to the motor flange using the motor mounting screws (that are to be prepared by the customer).
- 5) Tighten the motor flange to the housing B using motor flange mounting screws (included parts).

Match the convex part of the motor hub to the concave part of the spider that is mounted on the body side hub.

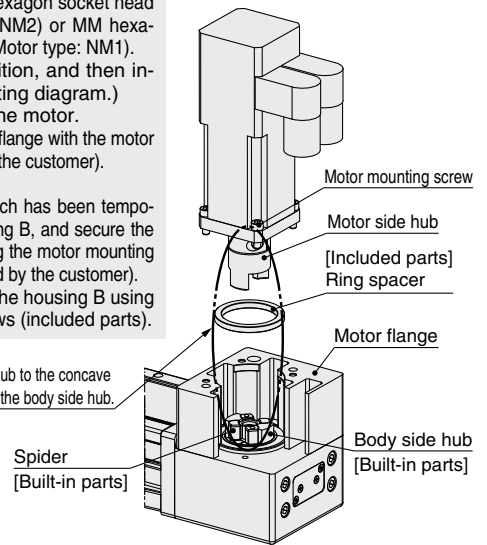

Size: 25 Hub Mounting Dimensions [mm]

Motor type	MM	TT	PD	FP
NZ	M2.5 x 10	1.0	8	11
NY	M2.5 x 10	1.0	8	11
NX	M2.5 x 10	1.0	8	5.5
NM1	M3 x 4	0.63	5	11
NM2	M2.5 x 10	1.0	6	11

Size: 32 Hub Mounting Dimensions [mm]

Motor type	MM	TT	PD	FP
NZ	M3 x 12	1.5	14	17.5
NY	M4 x 12	2.5	11	17.5
NX	M4 x 12	2.5	9	5.2
NW	M4 x 12	2.5	9	12.5
NV	M4 x 12	2.5	9	5.2
NU	M4 x 12	2.5	11	12.5
NT	M3 x 12	1.5	12	17.5
NM1	M4 x 5	1.5	6.35	4.5
NM2	M4 x 12	2.5	10	12

Size: 40 Hub Mounting Dimensions [mm]

Motor type	MM	TT	PD	FP
NZ	M3 x 12	1.5	14	17.5
NY	M3 x 12	1.5	14	17.5
NX	M4 x 12	2.5	9	5.2
NW	M4 x 12	2.5	9	13
NV	M4 x 12	2.5	9	5.2
NU	M4 x 12	2.5	11	13
NT	M3 x 12	1.5	12	17.5
NM1	M4 x 5	1.5	6.35	5
NM2	M4 x 12	2.5	10	12

Included Parts List

Size: 25

Description	Quantity				
	Motor type				
	NZ	NY	NX	NM1	NM2
Motor side hub	1	1	1	1	1
Hexagon socket head cap screw/set screw (to secure the hub)*1	1	1	1	1	1
Hexagon socket head cap screw (to secure the motor flange)*1	—	—	—	2	2
Ring spacer	—	—	—	1	1

*1 For screw sizes, refer to the hub mounting dimensions.

Size: 32, 40

Description	Quantity									
	Motor type									
	NZ	NY	NX	NW	NV	NU	NT	NM1	NM2	
Motor side hub	1	1	1	1	1	1	1	1	1	
Hexagon socket head cap screw/set screw (to secure the hub)*1	1	1	1	1	1	1	1	1	1	
Ring spacer	—	—	1	—	1	—	—	1	1	

*1 For screw sizes, refer to the hub mounting dimensions.

LEFB Series Motor Mounting Parts

Motor Flange Option

After purchasing the product, the motor can be changed to the motor types shown below by replacing with this option. (Except NM1)
Use the following part numbers to select a compatible motor flange option and place an order.

How to Order

LEFB-MF25-NZ

Belt drive

①

②

① Size

25	For LEF□25
32	For LEF□32
40	For LEF□40

② Motor type

Symbol	Type	Symbol	Type
NZ	Mounting type Z	NV	Mounting type V
NY	Mounting type Y	NU	Mounting type U
NX	Mounting type X	NT	Mounting type T
NW	Mounting type W	NM2	Mounting type M2

* Select only NZ, NY, NX or NM2 for the LEFB-MF25.

Compatible Motors

Applicable motor model			Size/Motor type											
Manufacturer	Series	Type	25				32/40							
			NZ Mounting type Z	NY Mounting type Y	NX Mounting type X	NM2 Mounting type M2	NZ Mounting type Z	NY Mounting type Y	NX Mounting type X	NW Mounting type W	NV Mounting type V	NU Mounting type U	NT Mounting type T	NM2 Mounting type M2
Mitsubishi Electric Corporation	MELSERVO-JN	HF-KN	●	—	—	—	●	—	—	—	—	—	—	—
	MELSERVO-J4	HG-KR	●	—	—	—	●	—	—	—	—	—	—	—
	MELSERVO-J5	HK-KT	●	—	—	—	●	—	—	—	—	—	—	—
YASKAWA Electric Corporation	Σ-V	SGMJV	●	—	—	—	●	—	—	—	—	—	—	—
	Σ-7	SGM7J/SGM7A	●	—	—	—	●	—	—	—	—	—	—	—
SANYO DENKI CO., LTD.	SANMOTION R	R2	●	—	—	—	●	—	—	—	—	—	—	—
OMRON Corporation	Sysmac G5	R88M-K	●	—	—	—	—	●	—	—	—	—	—	—
	1 S	R88M-1	●	—	—	—	—	●	—	—	—	—	—	—
Panasonic Corporation	MINAS A5	MSM□/MHMD	—	●	—	—	—	●	—	—	—	—	—	—
	MINAS A6	MSMF	—	●	—	—	—	●	—	—	—	—	—	—
		MHMF	●	—	—	—	—	●	—	—	—	—	—	—
FANUC CORPORATION	βis (-B)	β	●	—	—	—	● (β1 only)	—	—	●	—	—	—	—
NIDEC SANKYO CORPORATION	S-FLAG	MA/MH/MM	●	—	—	—	●	—	—	—	—	—	—	—
KEYENCE CORPORATION	SV	SV-M/SV-B	●	—	—	—	●	—	—	—	—	—	—	—
	SV2	SV2-M/SV2-B	●	—	—	—	●	—	—	—	—	—	—	—
FUJI ELECTRIC CO., LTD.	ALPHA5	GYS/GYB	●	—	—	—	●	—	—	—	—	—	—	—
	ALPHA7	GYS/GYB	●	—	—	—	●	—	—	—	—	—	—	—
	FALDIC α	GYS	●	—	—	—	●	—	—	—	—	—	—	—
ORIENTAL MOTOR Co., Ltd.	AR/AZ	AR/AZ (46 only)	—	—	—	●	—	—	—	—	—	—	—	—
	AR/AZ	AR/AZ	—	—	—	—	—	—	—	—	—	—	—	●
Rockwell Automation, Inc. (Allen-Bradley)	MP-/VP-	MP/VP	—	—	—	—	—	—	●	—	—	—	—	—
	TL	TLY-A	●	—	—	—	—	—	—	—	—	—	●	—
Beckhoff Automation GmbH	AM	AM30	●	—	—	—	—	—	—	—	●	—	—	—
	AM	AM31	●	—	—	—	—	—	—	—	—	●	—	—
	AM	AM80/AM81	●	—	—	—	—	—	—	●	—	—	—	—
Siemens AG	1FK7	1FK7	—	—	●	—	—	—	●	—	—	—	—	—
Delta Electronics, Inc.	ASDA-A2	ECMA	●	—	—	—	●	—	—	—	—	—	—	—
ANCA Motion	AMD2000	Alpha	●	—	—	—	●	—	—	—	—	—	—	—

* When the LEF□25NM1□-□ is purchased, it is not possible to change to other motor types.

LEFB Series

Dimensions: Motor Flange Option

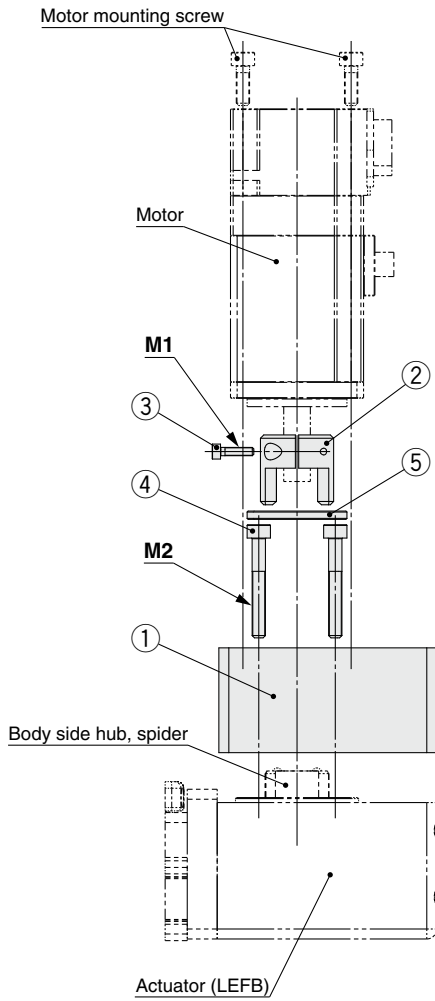

Component Parts

No.	Description	Quantity
1	Motor flange	1
2	Hub (Motor side)	1
3	Hexagon socket head cap screw (to secure the hub)	1
4	Hexagon socket head cap screw (to mount the motor flange)	2
5	Ring spacer (Only for NX, NV and NM2 of size 32, 40)	1

Motor flange details

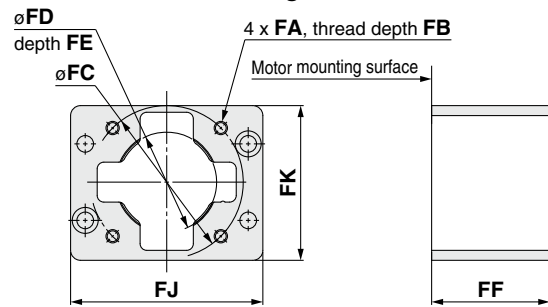

For NM2

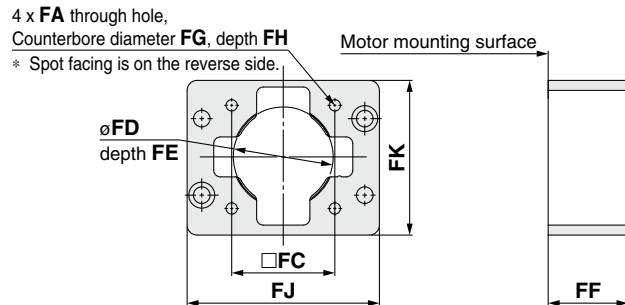

Dimensions

Size	Motor type	FA	FB	FC	FD	FE	FF	FG	FH	FJ	FK	M1	M2	PD
25	NZ/NX	M4 x 0.7	8	46	30	3.5	31.5	—	—	57.8	65.5	M2.5 x 10	M4 x 30	8
	NY	M3 x 0.5	8	45	30	3.5	31.5	—	—	57.8	65.5	M2.5 x 10	M4 x 30	8
	NM2	$\phi 3.4$	—	31	22*	2.5*	31.5	6	21	57.8	65.5	M2.5 x 10	M4 x 30	6
32	NZ	M5 x 0.8	9	70	50	4	44	—	—	69.8	83.5	M3 x 12	M5 x 45	14
	NY	M4 x 0.7	8	70	50	4	44	—	—	69.8	83.5	M4 x 12	M5 x 45	11
	NX	M5 x 0.8	9	63	50	5	47.7	—	—	69.8	83.5	M4 x 12	M5 x 45	9
	NW	M5 x 0.8	9	70	50	5	45	—	—	69.8	83.5	M4 x 12	M5 x 45	9
	NV	M4 x 0.7	8	63	50	5	47.7	—	—	69.8	83.5	M4 x 12	M5 x 45	9
	NU	M5 x 0.8	9	70	50	5	45	—	—	69.8	83.5	M4 x 12	M5 x 45	11
	NT	M5 x 0.8	9	70	50	4	44	—	—	69.8	83.5	M3 x 12	M5 x 45	12
	NM2	M4 x 0.7	8	50	36*	4.5*	38.5	—	—	69.8	83.5	M4 x 12	M5 x 25	10
40	NZ	M5 x 0.8	9	70	50	4	44	—	—	89.8	85	M3 x 12	M5 x 45	14
	NY	M4 x 0.7	8	70	50	4	44	—	—	89.8	85	M3 x 12	M5 x 45	14
	NX	M5 x 0.8	9	63	50	5	47.2	—	—	89.8	85	M4 x 12	M5 x 45	9
	NW	M5 x 0.8	9	70	50	5	45	—	—	89.8	85	M4 x 12	M5 x 45	9
	NV	M4 x 0.7	8	63	50	5	47.2	—	—	89.8	85	M4 x 12	M5 x 45	9
	NU	M5 x 0.8	9	70	50	5	45	—	—	89.8	85	M4 x 12	M5 x 45	11
	NT	M5 x 0.8	9	70	50	4	44	—	—	89.8	85	M3 x 12	M5 x 45	12
	NM2	M4 x 0.7	8	50	36*	4.5*	38	—	—	89.8	85	M4 x 12	M5 x 25	10

LEF Series Auto Switch Mounting

Auto Switch Mounting Position

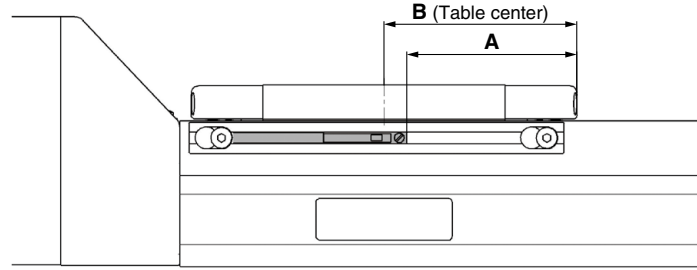

Model	Size	A	B	Operating range
LEFS LEFB	25	45	51	4.9
	32	55	61	3.9
	40	79	85	5.3

- * The applicable auto switch is D-M9 (N/P/B) (W) (M/L/Z).
- * The operating range is a guideline including hysteresis, not meant to be guaranteed. There may be large variations depending on the ambient environment.
- * Adjust the auto switch after confirming the operating conditions in the actual setting.

Auto Switch Mounting

Rotate the bolts for auto switch mounting bracket three to four times to loosen them (Removing them is not required), and slide and remove the auto switch mounting bracket. Then, insert a switch into the groove on the mounting bracket.

As the mounting bolts for installing the product body interfere with the auto switch mounting bracket, mount the auto switch mounting bracket after installing the product body. After installing product body, tighten the bolts for the auto switch mounting bracket.

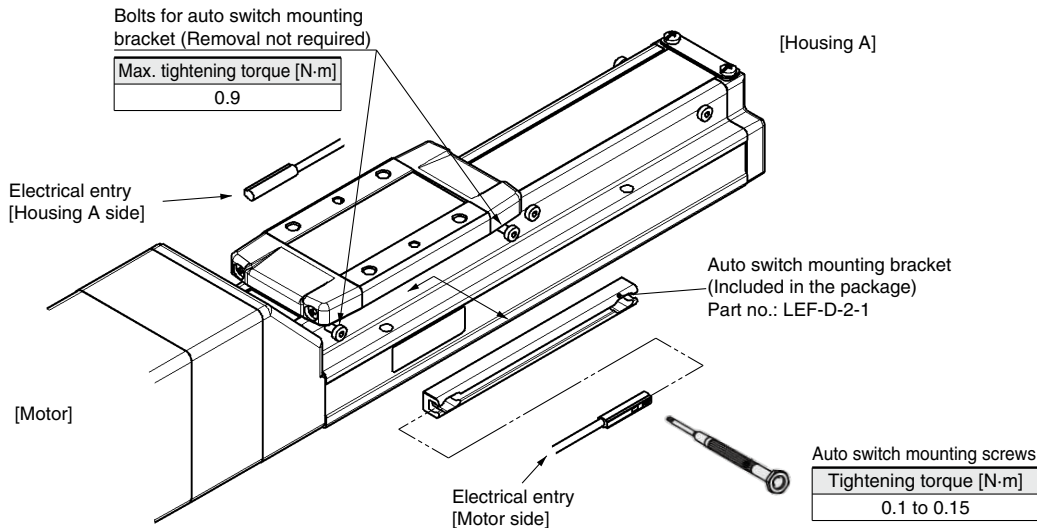

- * The applicable auto switch is D-M9 (N/P/B) (W) (M/L/Z).
- * The direction of the lead wire entry is specified. If it is mounted in the opposite direction, the auto switch may malfunction.
- * Tighten the auto switch mounting screws (provided together with the auto switch), using a precision screwdriver with a handle diameter of approximately 5 to 6 mm.
- * If more than two auto switch mounting brackets are required, please order them separately. All eight bolts for attaching the auto switch mounting bracket at the stroke end are tightened into the body when the product is shipped. For strokes of 99 mm or less, only four bolts are tightened on the motor side.

Solid State Auto Switch Direct Mounting Type D-M9N/D-M9P/D-M9B



Refer to the SMC website for details on products that are compliant with international standards.

Auto Switch Specifications

PLC: Programmable Logic Controller

D-M9□, D-M9□V (With indicator light)			
Auto switch model	D-M9N	D-M9P	D-M9B
Electrical entry direction	In-line		
Wiring type	3-wire		2-wire
Output type	NPN	PNP	—
Applicable load	IC circuit, Relay, PLC		24 VDC relay, PLC
Power supply voltage	5, 12, 24 VDC (4.5 to 28 V)		—
Current consumption	10 mA or less		—
Load voltage	28 VDC or less	—	24 VDC (10 to 28 VDC)
Load current	40 mA or less		2.5 to 40 mA
Internal voltage drop	0.8 V or less at 10 mA (2 V or less at 40 mA)		4 V or less
Leakage current	100 μA or less at 24 VDC		0.8 mA or less
Indicator light	Red LED illuminates when turned ON.		
Standard	CE marking, RoHS		

Grommet

- 2-wire load current is reduced (2.5 to 40 mA).
- Using flexible cable as standard spec.



Caution

Precautions

Fix the auto switch with the existing screw installed on the auto switch body. The auto switch may be damaged if a screw other than the one supplied is used.

Oilproof Heavy-duty Lead Wire Specifications

Auto switch model		D-M9N	D-M9P	D-M9B
Sheath	Outside diameter [mm]	2.6		
Insulator	Number of cores	3 cores (Brown/Blue/Black)		2 cores (Brown/Blue)
	Outside diameter [mm]	0.88		
Conductor	Effective area [mm ²]	0.15		
	Strand diameter [mm]	0.05		
Minimum bending radius [mm] (Reference values)		17		

- * Refer to page 996 for solid state auto switch common specifications.
- * Refer to page 996 for lead wire lengths.

Weight

[g]

Auto switch model		D-M9N	D-M9P	D-M9B
Lead wire length	0.5 m (Nil)	8	7	7
	1 m (M)	14	13	13
	3 m (L)	41	38	38
	5 m (Z)	68	63	63

Dimensions

[mm]

D-M9□

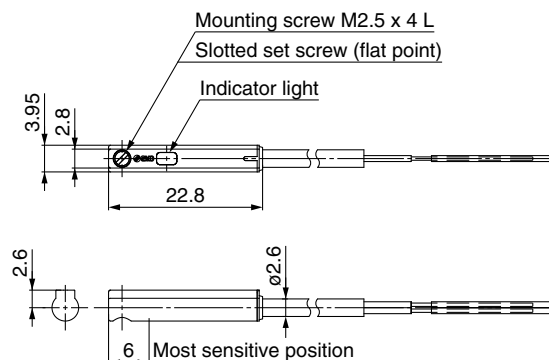

Normally Closed Solid State Auto Switch Direct Mounting Type

D-M9NE(V)/D-M9PE(V)/D-M9BE(V)



Refer to the SMC website for details on products that are compliant with international standards.

Grommet

- Output signal turns on when no magnetic force is detected.
- Can be used for the actuator adopted by the solid state auto switch D-M9 series (excluding special order products)



Caution

Precautions

Fix the auto switch with the existing screw installed on the auto switch body. The auto switch may be damaged if a screw other than the one supplied is used.

Auto Switch Specifications

PLC: Programmable Logic Controller

D-M9□E, D-M9□EV (With indicator light)						
Auto switch model	D-M9NE	D-M9NEV	D-M9PE	D-M9PEV	D-M9BE	D-M9BEV
Electrical entry direction	In-line	Perpendicular	In-line	Perpendicular	In-line	Perpendicular
Wiring type	3-wire				2-wire	
Output type	NPN		PNP		—	
Applicable load	IC circuit, Relay, PLC				24 VDC relay, PLC	
Power supply voltage	5, 12, 24 VDC (4.5 to 28 V)				—	
Current consumption	10 mA or less				—	
Load voltage	28 VDC or less		—		24 VDC (10 to 28 VDC)	
Load current	40 mA or less				2.5 to 40 mA	
Internal voltage drop	0.8 V or less at 10 mA (2 V or less at 40 mA)				4 V or less	
Leakage current	100 μA or less at 24 VDC				0.8 mA or less	
Indicator light	Red LED illuminates when turned ON.					
Standard	CE marking, RoHS					

Oilproof Heavy-duty Lead Wire Specifications

Auto switch model	D-M9NE(V)	D-M9PE(V)	D-M9BE(V)
Sheath	Outside diameter [mm]		
	2.6		
Insulator	Number of cores		2 cores (Brown/Blue)
	Outside diameter [mm]		0.88
Conductor	Effective area [mm ²]		0.15
	Strand diameter [mm]		0.05
Minimum bending radius [mm] (Reference values)			
17			

- * Refer to page 996 for solid state auto switch common specifications.
- * Refer to page 996 for lead wire lengths.

Weight

Auto switch model	D-M9NE(V)	D-M9PE(V)	D-M9BE(V)
Lead wire length	0.5 m (Nil)	8	7
	1 m (M)*1	14	13
	3 m (L)	41	38
	5 m (Z)*1	68	63

*1 The 1 m and 5 m options are produced upon receipt of order.

Dimensions

D-M9□E

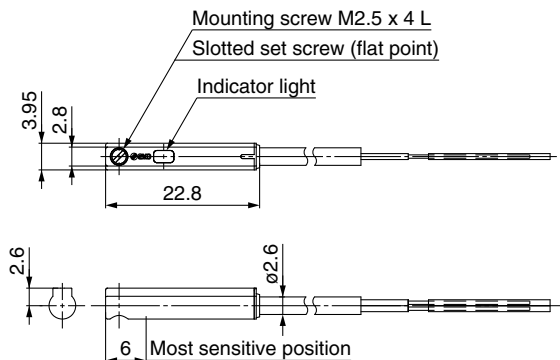

D-M9□EV

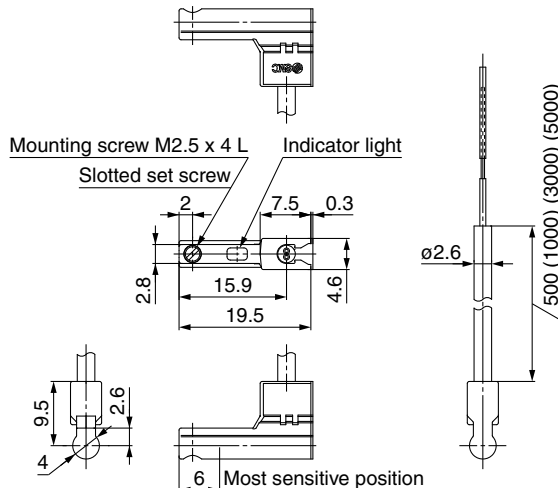

- LEFS
- LEFB
- LEJS
- LEJB
- LEL
- LEM
- LEMY
- LEYG
- LES
- LESH
- LEPY
- LEPS
- LER
- LEH
- LEH
- LEY-X5
- LEYS
- 11-LEFS
- 11-LEJS
- 25A-
- LEC□
- JXC□
- LECS□
- LECS□-T
- LECY□
- Motor/less
- LAT3

2-Color Indicator Solid State Auto Switch Direct Mounting Type

D-M9NW/D-M9PW/D-M9BW



Refer to the SMC website for details on products that are compliant with international standards.

Grommet

- 2-wire load current is reduced (2.5 to 40 mA).
- Using flexible cable as standard spec.
- The proper operating range can be determined by the color of the light. (Red → Green ← Red)



Caution

Precautions

Fix the auto switch with the existing screw installed on the auto switch body. The auto switch may be damaged if a screw other than the one supplied is used.

Auto Switch Specifications

PLC: Programmable Logic Controller

D-M9□W, D-M9□WV (With indicator light)			
Auto switch model	D-M9NW	D-M9PW	D-M9BW
Electrical entry direction	In-line		
Wiring type	3-wire		2-wire
Output type	NPN	PNP	—
Applicable load	IC circuit, Relay, PLC		24 VDC relay, PLC
Power supply voltage	5, 12, 24 VDC (4.5 to 28 V)		—
Current consumption	10 mA or less		
Load voltage	28 VDC or less	—	24 VDC (10 to 28 VDC)
Load current	40 mA or less		2.5 to 40 mA
Internal voltage drop	0.8 V or less at 10 mA (2 V or less at 40 mA)		4 V or less
Leakage current	100 μA or less at 24 VDC		0.8 mA or less
Indicator light	Operating range Red LED illuminates. Proper operating range Green LED illuminates.		
Standard	CE marking, RoHS		

Oilproof Flexible Heavy-duty Lead Wire Specifications

Auto switch model		D-M9NW	D-M9PW	D-M9BW
Sheath	Outside diameter [mm]	2.6		
Insulator	Number of cores	3 cores (Brown/Blue/Black)		2 cores (Brown/Blue)
	Outside diameter [mm]	0.88		
Conductor	Effective area [mm ²]	0.15		
	Strand diameter [mm]	0.05		
Minimum bending radius [mm] (Reference values)		17		

- * Refer to page 996 for solid state auto switch common specifications.
- * Refer to page 996 for lead wire lengths.

Weight

[g]

Auto switch model		D-M9NW	D-M9PW	D-M9BW
Lead wire length	0.5 m (Nil)	8	7	7
	1 m (M)	14	13	13
	3 m (L)	41	38	38
	5 m (Z)	68	63	63

Dimensions

[mm]

D-M9□W

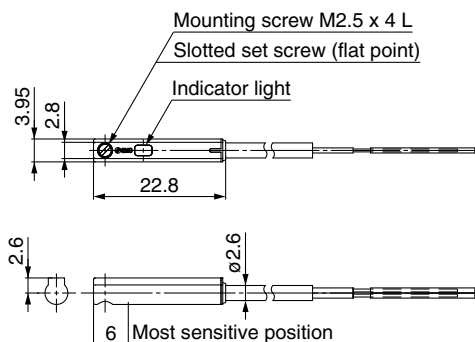



LEF Series Specific Product Precautions 1

Be sure to read this before handling the products. Refer to page 984 for safety instructions, pages 985 to 990 for electric actuator precautions, and pages 991 to 1000 for auto switch precautions.

Design

⚠ Caution

- Do not apply a load in excess of the specification limits.**
Select a suitable actuator by work load and allowable moment. If a load in excess of the specification limits is applied to the guide, adverse effects such as the generation of play in the guide, reduced accuracy, or reduced service life of the product may occur.
- Do not use the product in applications where excessive external force or impact force is applied to it.**
This can cause a malfunction.

Selection

⚠ Warning

- Do not increase the speed in excess of the specification limits.**
Select a suitable actuator by the relationship of the allowable work load and speed, and the allowable speed of each stroke. If the product is used outside of the specification limits, adverse effects such as the generation of noise, reduced accuracy, or reduced service life of the product may occur.
- Do not use the product in applications where excessive external force or impact force is applied to it.**
This can cause a malfunction.
- When the product repeatedly cycles with partial strokes (see the table below), operate it at a full stroke at least once every few dozens of cycles.**
Failure to do so may result in the product running out of lubrication.

Model	Partial stroke
LEF□25	65 mm or less
LEF□32	70 mm or less
LEF□40	105 mm or less

- When external force is to be applied to the table, it is necessary to add the external force to the work load as the total carried load when selecting a size.**
When a cable duct or flexible moving tube is attached to the actuator, the sliding resistance of the table will increase, which may lead to the malfunction of the product.
- Depending on the shape of the motor to be mounted, some of the product's interior parts (hub, spider, etc.) may be visible from the motor mounting surface. If this is undesirable, please contact your nearest sales office for details on options such as covers.**

Handling

⚠ Caution

- Never allow the table to collide with the stroke end.**
When the driver parameters, origin or programs are set incorrectly, the table may collide with the stroke end of the actuator during operation. Be sure to check these points before use. If the table collides with the stroke end of the actuator, the guide, ball screw, belt, or internal stopper may break. This can result in abnormal operation.

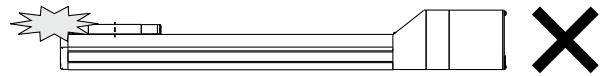

Handle the actuator with care when it is used in the vertical direction as the workpiece will fall freely from its own weight.

- The actual speed of this actuator is affected by the work load and stroke.**
Check the model selection section of the catalog.
- Do not apply a load, impact, or resistance in addition to the transferred load during return to origin.**
- Do not dent, scratch, or cause other damage to the body or table mounting surfaces.**
Doing so may cause unevenness in the mounting surface, play in the guide, or an increase in the sliding resistance.
- Do not apply strong impact or an excessive moment while mounting a workpiece.**
If an external force over the allowable moment is applied, it may cause play in the guide or an increase in the sliding resistance.
- Keep the flatness of the mounting surface within 0.1 mm/500 mm.**
If a workpiece or base does not sit evenly on the body of the product, play in the guide or an increase in the sliding resistance may occur.
- Do not allow a workpiece to collide with the table during the positioning operation or within the positioning range.**
- Grease is applied to the dust seal band for sliding. When wiping off the grease to remove foreign matter, etc., be sure to apply it again.**
- When bottom mounted, the dust seal band may become warped.**

LEFS
LEFBLEJS
LEJB

LEL

LEM
LEMBLEY
LEYGLES
LESHLEPY
LEPS

LER

LEH

LEY-X5

11-LEFS

11-LEJS

25A-

LEC□

JXC□

LECS□
LECS□-T

LECY□

Motorless

LAT3



LEF Series Specific Product Precautions 2

Be sure to read this before handling the products. Refer to page 984 for safety instructions, pages 985 to 990 for electric actuator precautions, and pages 991 to 1000 for auto switch precautions.

Handling

⚠ Caution

10. When mounting the product, use screws of adequate length and tighten them with adequate torque.

Tightening the screws with a higher torque than recommended may result in a malfunction, while tightening with a lower torque can result in the displacement of the mounting position or, in extreme conditions, the actuator could become detached from its mounting position.

Body fixed

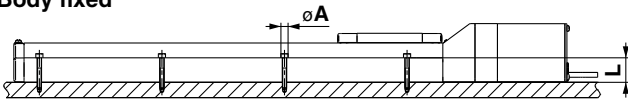

Model	Screw size	Max. tightening torque [N·m]	ϕA [mm]	L [mm]
LEF□25	M4	1.5	4.5	24
LEF□32	M5	3.0	5.5	30
LEF□40	M6	5.2	6.6	31

Body mounting

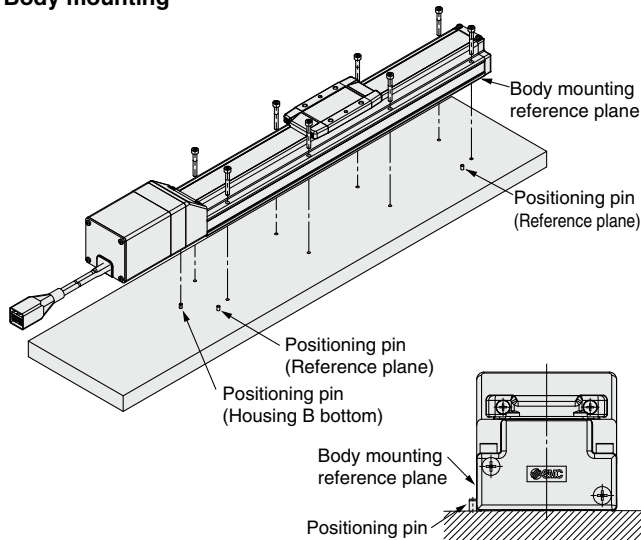

The traveling parallelism is the reference plane for the body mounting reference plane. If the traveling parallelism for a table is required, set the reference plane against parallel pins, etc.

Workpiece fixed

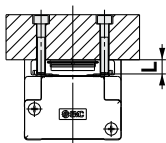

Model	Screw size	Max. tightening torque [N·m]	L (Max. screw-in depth) [mm]
LEF□25	M5 x 0.8	3.0	8
LEF□32	M6 x 1	5.2	9
LEF□40	M8 x 1.25	12.5	13

To prevent the workpiece retaining screws from touching the body, use screws that are 0.5 mm or shorter than the maximum screw-in depth. If long screws are used, they may touch the body and cause a malfunction.

11. Do not operate by fixing the table and moving the actuator body.

12. The belt drive actuator cannot be used for vertical applications.

13. Check the specifications for the minimum speed of each actuator.

Failure to do so may result in unexpected malfunctions such as knocking.

14. In the case of the belt drive actuator, vibration may occur during operation at speeds within the actuator specifications due to the operating conditions. Change the speed setting to a speed that does not cause vibration.

Maintenance

⚠ Warning

Maintenance frequency

Perform maintenance according to the table below.

Frequency	Appearance check	Internal check
Inspection before daily operation	○	—
Inspection every 6 months/1000 km/5 million cycles*1	○	○

*1 Select whichever comes first.

● Items for visual appearance check

1. Loose set screws, Abnormal amount of dirt, etc.
2. Check for visible damage, Check of cable joint
3. Vibration, Noise

● Items for internal check

1. Lubricant condition on moving parts
2. Loose or mechanical play in fixed parts or fixing screws

High Rigidity Slider Type

Ball Screw Drive *LEJS Series*

p. 875



- LEFS
LEFB
- LEJS
LEJB
- LEL
- LEM
- LEY
LEYG
- LES
LESH
- LEPY
LEPS
- LER
- LEH
- LEY-X5
- 11-LEFS
- 11-LEJS
- 25A-
- LEC
- JXC
- LECS
LECS-T
- LECY
- Motorless
- LAT3

Model Selection



LEJS Series ▶ p. 885 LEJS-M Series ▶ p. 889

Selection Procedure



Selection Example

The model selection method shown below corresponds to SMC's standard motor. For use in combination with a motor from a different manufacturer, check the available product information of the motor to be used.

Operating conditions

- Work load: 60 [kg]
 - Speed: 300 [mm/s]
 - Acceleration/Deceleration: 3000 [mm/s²]
 - Stroke: 300 [mm]
 - Mounting orientation: Horizontal
 - External force: 10 [N]
- Workpiece mounting condition:
-

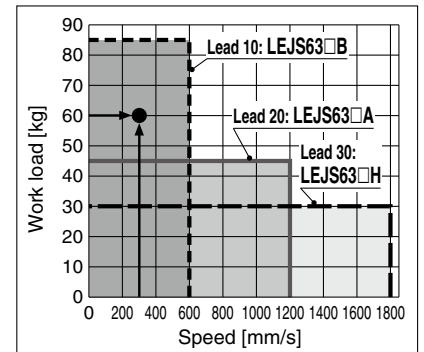

<Speed-Work Load Graph>
(LEJS63)

Step 1 Check the speed-work load.

Select a model based on the workpiece mass and speed which are within the range of the actuator body specifications while referencing the speed-work load graph (guide) on page 876.

Selection example) The LEJS63□B-300 can be temporarily selected as a possible candidate based on the graph shown on the right side.

* Refer to the selection method of motor manufacturers for regeneration resistance.

Step 2 Check the cycle time.

Refer to method 1 for a rough estimate, and method 2 for a more precise value.

Method 1: Check the cycle time graph. (Page 877)

The graph is based on the maximum speed of each size.

Method 2: Calculation

Cycle time:

T can be found from the following equation.

$$T = T1 + T2 + T3 + T4 \text{ [s]}$$

- T1 and T3 can be found by the following equation.

$$T1 = V/a1 \text{ [s]} \quad T3 = V/a2 \text{ [s]}$$

The acceleration and deceleration values have upper limits depending on the workpiece mass and the duty ratio.

Confirm that they do not exceed the upper limit, by referring to the "Work load-Acceleration/Deceleration Graph (Guide)" on pages 878 and 879.

For the ball screw type, there is an upper limit of the speed depending on the stroke. Confirm that it does not exceed the upper limit, by referring to the specifications on page 886.

- T2 can be found from the following equation.

$$T2 = \frac{L - 0.5 \cdot V \cdot (T1 + T3)}{V} \text{ [s]}$$

- T4 varies depending on the motor type and load. The value below is recommended.

$$T4 = 0.05 \text{ [s]}$$

* The conditions for the settling time vary depending on the motor or driver to be used.

Calculation example)

T1 to T4 can be calculated as follows.

$$T1 = V/a1 = 300/3000 = 0.1 \text{ [s]}$$

$$T3 = V/a2 = 300/3000 = 0.1 \text{ [s]}$$

$$T2 = \frac{L - 0.5 \cdot V \cdot (T1 + T3)}{V} = \frac{300 - 0.5 \cdot 300 \cdot (0.1 + 0.1)}{300} = 0.90 \text{ [s]}$$

$$T4 = 0.05 \text{ [s]}$$

The cycle time can be found as follows.

$$T = T1 + T2 + T3 + T4 = 0.1 + 0.90 + 0.1 + 0.05 = 1.15 \text{ [s]}$$

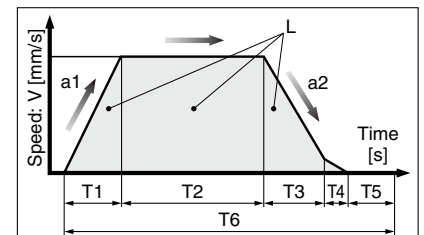

L : Stroke [mm]
V : Speed [mm/s]
a1 : Acceleration [mm/s²]
a2 : Deceleration [mm/s²]

- T1: Acceleration time [s]
Time until reaching the set speed
- T2: Constant speed time [s]
Time while the actuator is operating at a constant speed
- T3: Deceleration time [s]
Time from the beginning of the constant speed operation to stop
- T4: Settling time [s]
Time until positioning is completed
- T5: Resting time [s]
Time the product is not running
- T6: Total time [s]
Total time from T1 to T5

Duty ratio: Ratio of T to T6
 $T \div T6 \times 100$

Step 3 Check the allowable moment.

Refer to the "Dynamic Allowable Moment" graphs on pages 880 and 881.

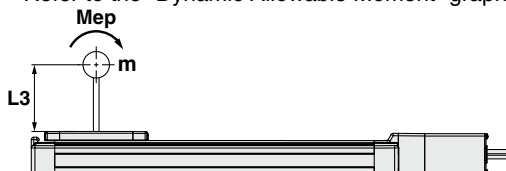

Selection example)

Select the LEJS63□B-300 from the graph on the right side.

Confirm that the external force is within the allowable external force (20 [N]).

(The external force is the resistance due to cable duct, flexible trunking or air tubing.)

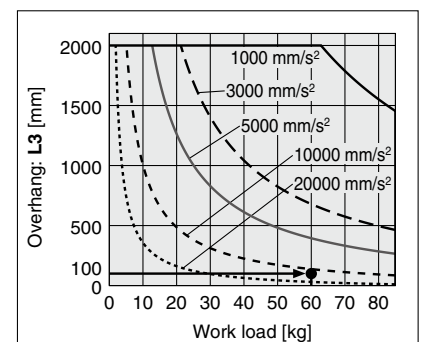

<Dynamic Allowable Moment>
(LEJS63)

* The values shown below are allowable values of the actuator body. Do not use the actuator so that it exceeds these specification ranges.

* The allowable speed is restricted depending on the stroke. Select it by referring to the "Allowable Stroke Speed."

Speed-Work Load Graph (Guide)

LEJS40/Ball Screw Drive

Horizontal

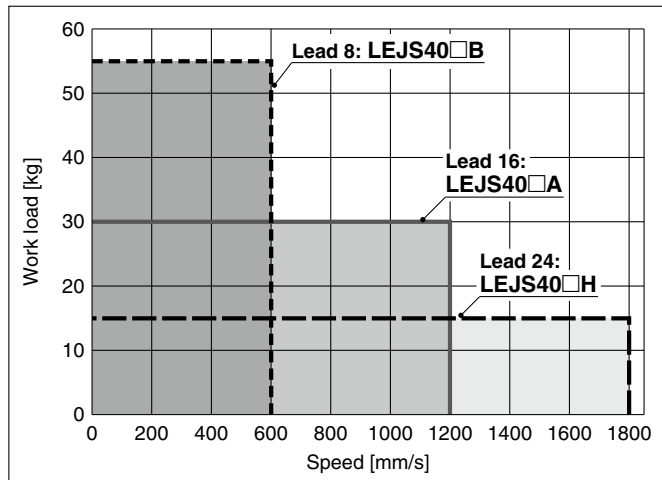

Vertical

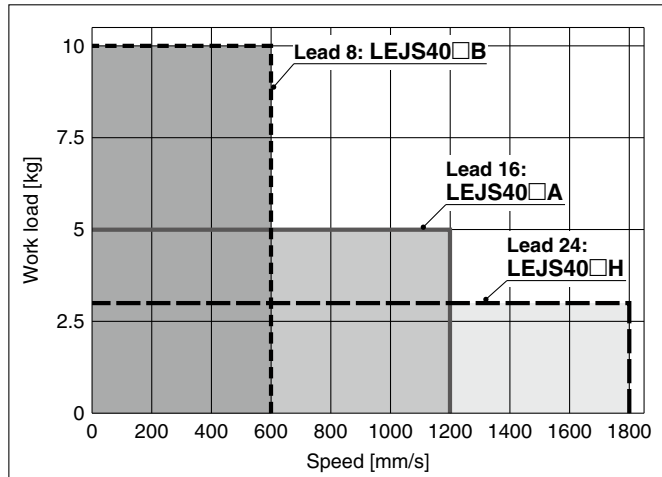

LEJS63/Ball Screw Drive

Horizontal

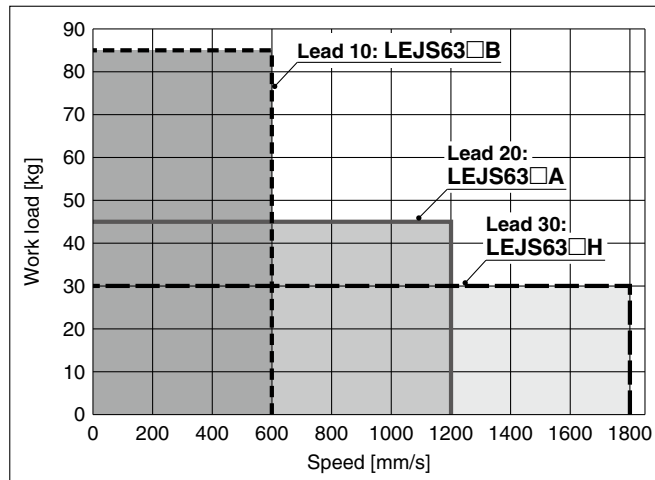

Vertical

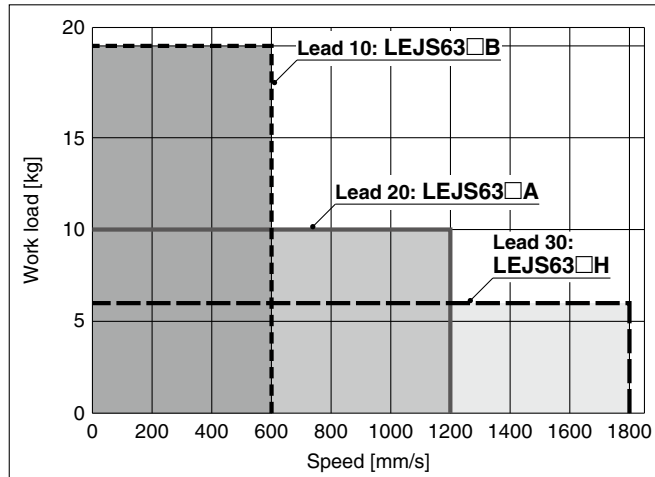

Allowable Stroke Speed

Model	Motor	Lead		Stroke [mm]														
		Symbol	[mm]	Up to 200	Up to 300	Up to 400	Up to 500	Up to 600	Up to 700	Up to 800	Up to 900	Up to 1000	Up to 1100	Up to 1200	Up to 1300	Up to 1400	Up to 1500	
LEJS40	100 W equivalent	H	24			1800			1580	1170	910	720	580	480	410	—	—	—
		A	16			1200			1050	780	600	480	390	320	270	—	—	—
		B	8			600			520	390	300	240	190	160	130	—	—	—
		(Motor rotation speed)		(4500 rpm)			(3938 rpm)			(2925 rpm)	(2250 rpm)	(1800 rpm)	(1463 rpm)	(1200 rpm)	(1013 rpm)	—	—	—
LEJS63	200 W equivalent	H	30	—			1800			1390	1110	900	750	630	540	470	410	
		A	20	—			1200			930	740	600	500	420	360	310	270	
		B	10	—			600			460	370	300	250	210	180	150	130	
		(Motor rotation speed)		(3600 rpm)			(2790 rpm)			(2220 rpm)	(1800 rpm)	(1500 rpm)	(1260 rpm)	(1080 rpm)	(930 rpm)	(810 rpm)	—	—

- LEFS
- LEFB
- LEJS
- LEJB
- LEL
- LEM
- LEY
- LEYG
- LES
- LESH
- LEPY
- LEPS
- LER
- LEH
- LEH
- LEY-X5
- 11-LEFS
- 11-LEJS
- 25A-
- LEC
- JXC
- LECS
- LECS-T
- LECY
- Motorless
- LAT3

Cycle Time Graph (Guide)

LEJS40/Ball Screw Drive

LEJS40□H

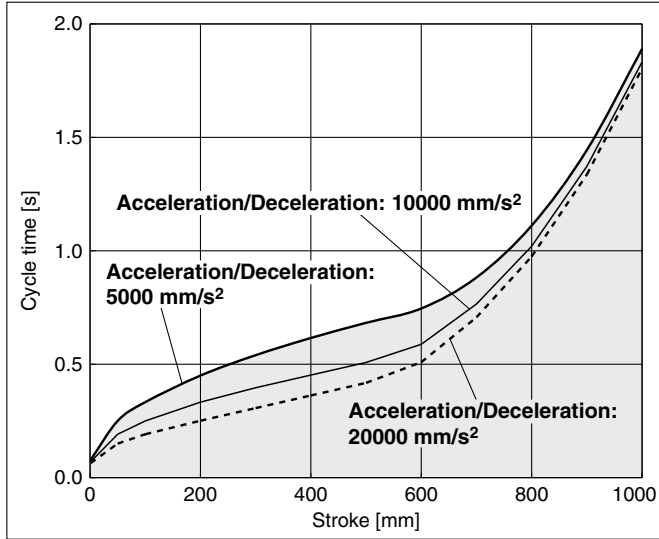

LEJS40□A

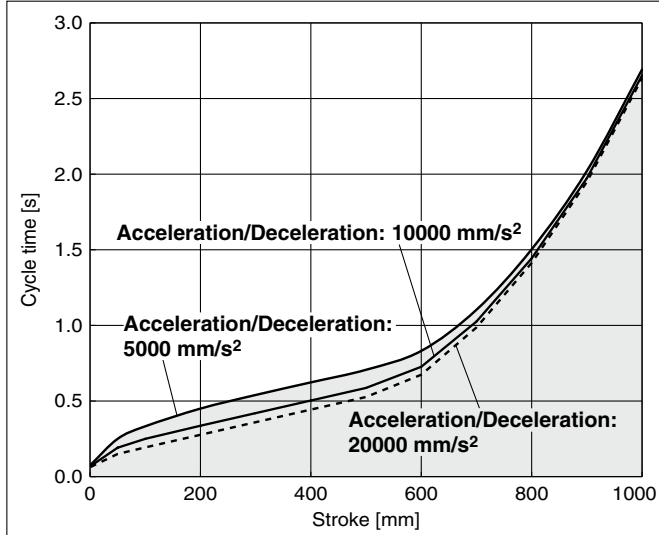

LEJS40□B

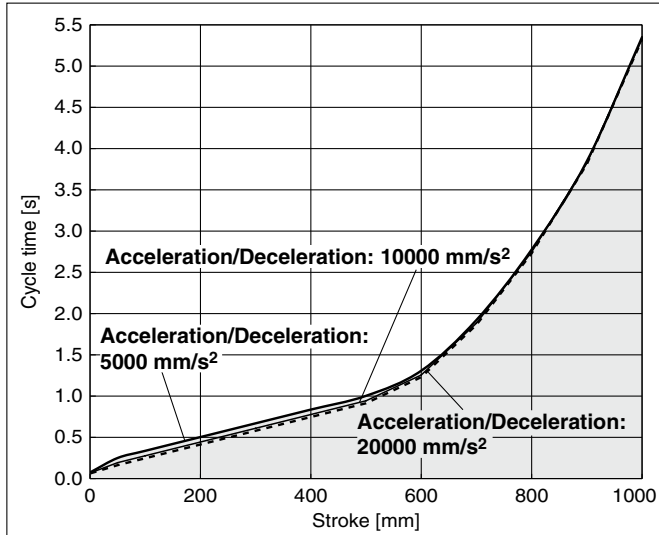

LEJS63/Ball Screw Drive

LEJS63□H

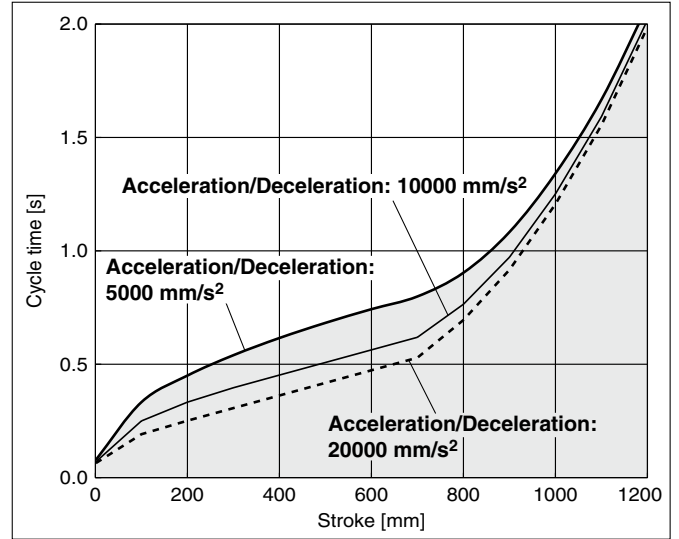

LEJS63□A

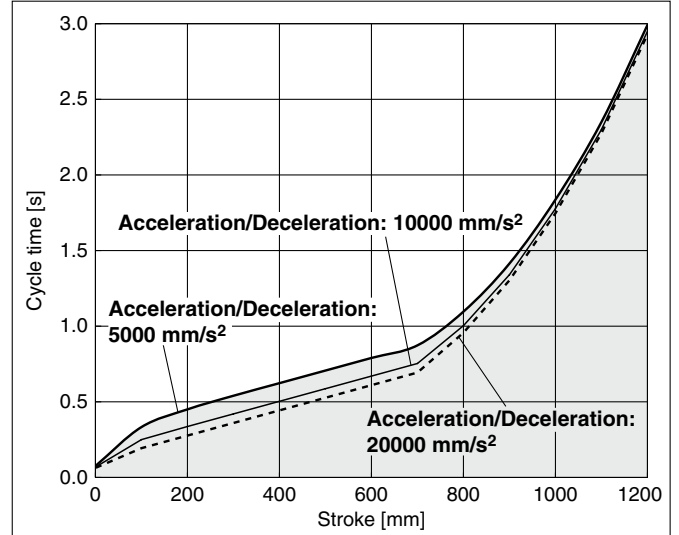

LEJS63□B

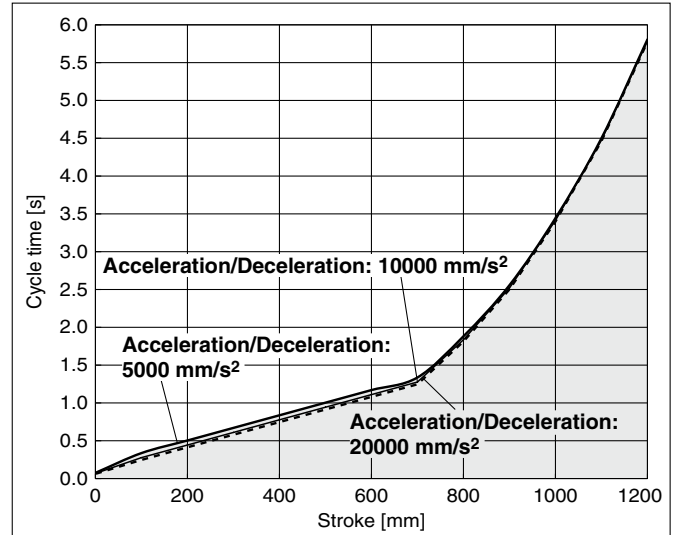

* These graphs show the cycle time for each acceleration/deceleration.
 * These graphs show the cycle time for each stroke at the maximum speed.

Work Load–Acceleration/Deceleration Graph (Guide)

LEJS40/Ball Screw Drive: Horizontal

LEJS40□H

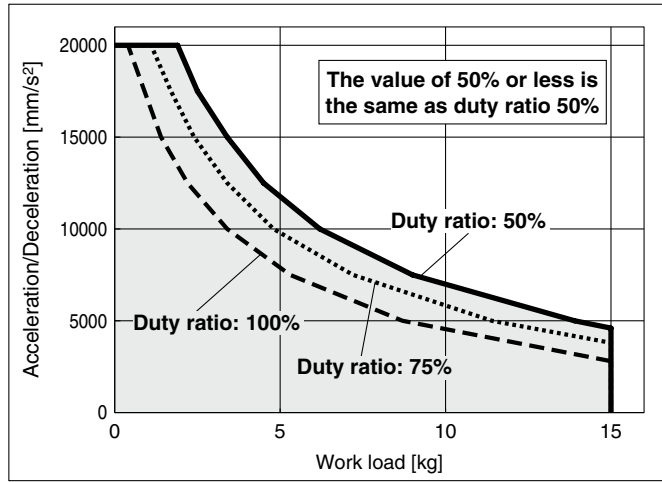

LEJS63/Ball Screw Drive: Horizontal

LEJS63□H

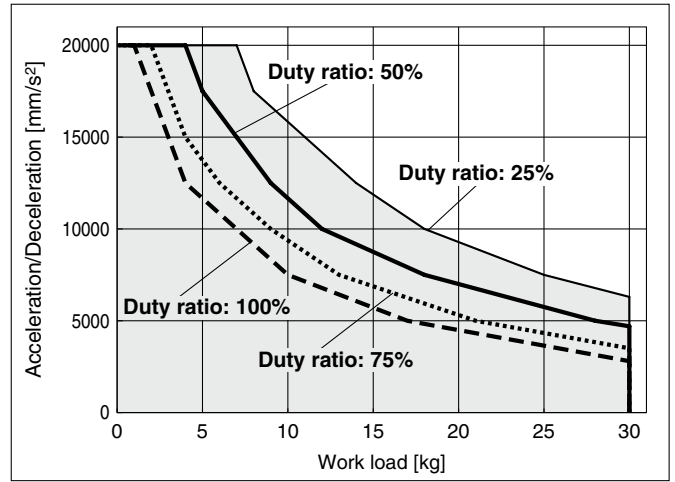

LEJS40□A

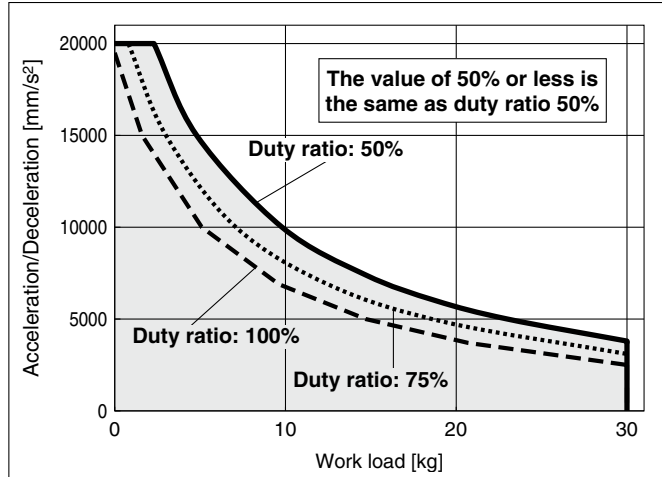

LEJS63□A

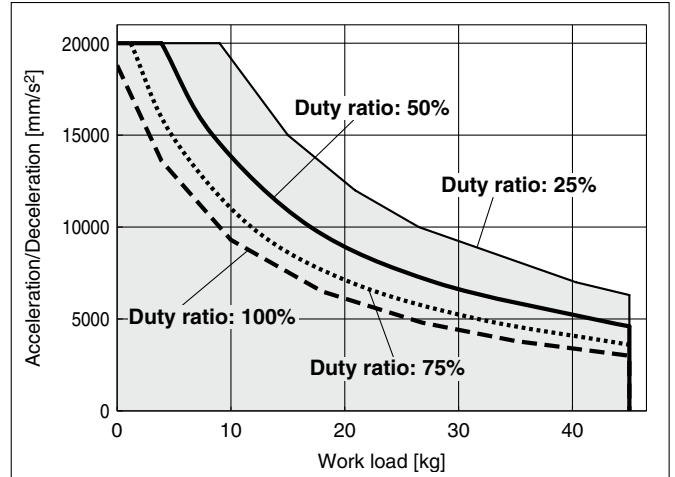

LEJS40□B

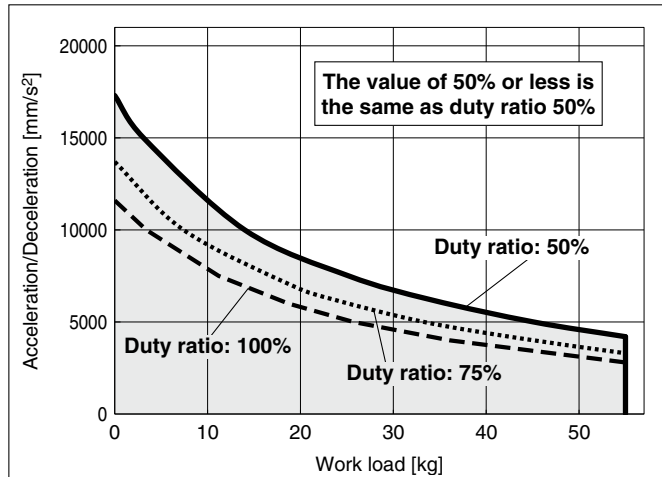

LEJS63□B

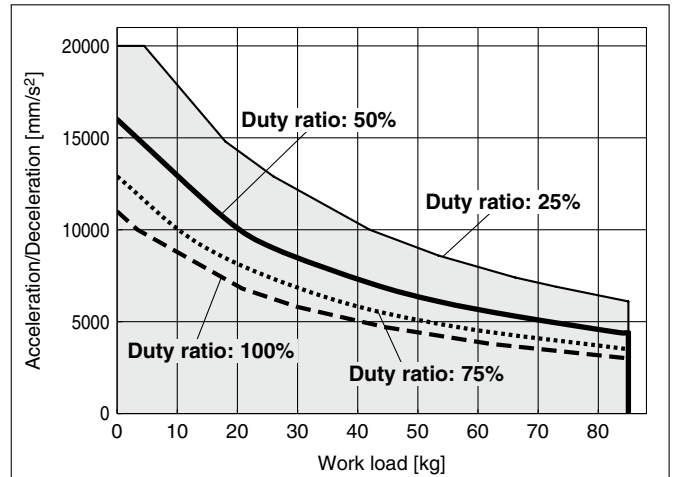

These graphs are examples of when the standard motor is mounted.
Determine the duty ratio after taking into account the load factor of the motor or driver to be used.

- LEFS
- LEFB
- LEJS
- LEJB
- LEL
- LEM
- LEYG
- LEYS
- LESH
- LEPY
- LEPS
- LER
- LEH
- LEY-X5
- 11-LEFS
- 11-LEJS
- 25A-
- LEC□
- JXC□
- LECS□
- LECS□-T
- LECY□
- Motorless
- LAT3

Work Load–Acceleration/Deceleration Graph (Guide)

LEJS40/Ball Screw Drive: Vertical

LEJS40□H

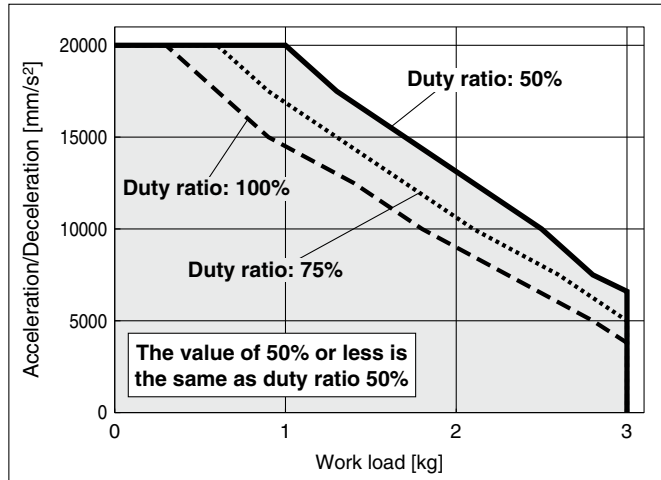

LEJS63/Ball Screw Drive: Vertical

LEJS63□H

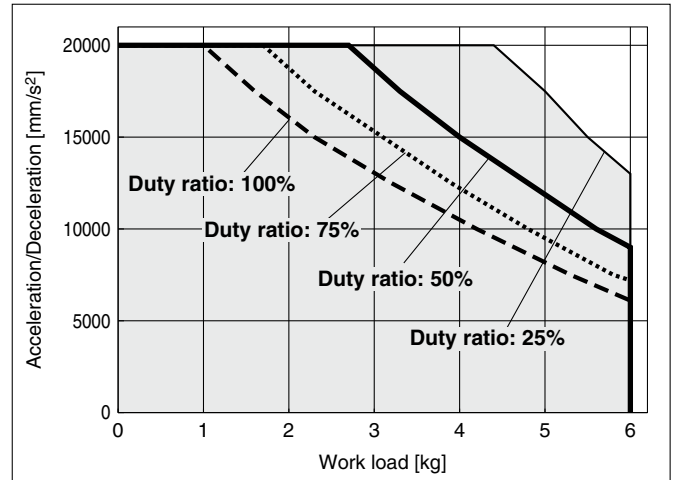

LEJS40□A

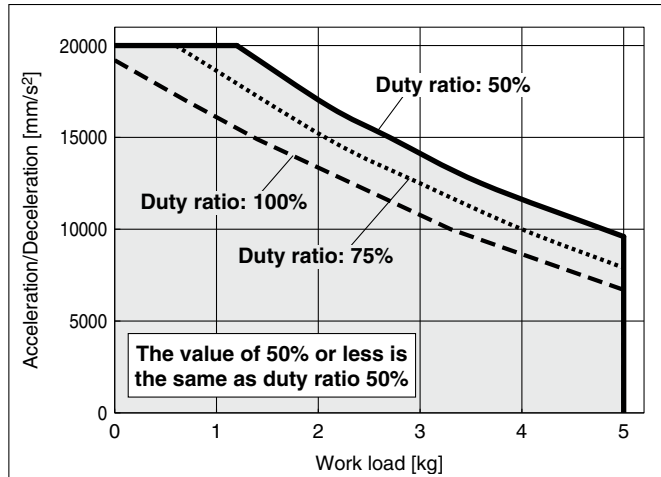

LEJS63□A

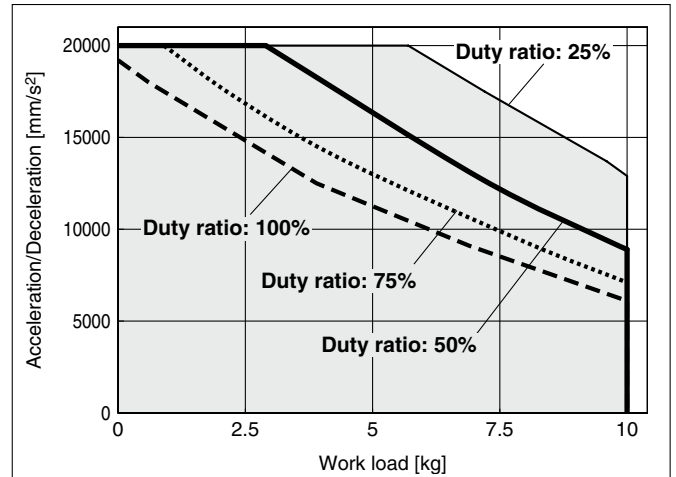

LEJS40□B

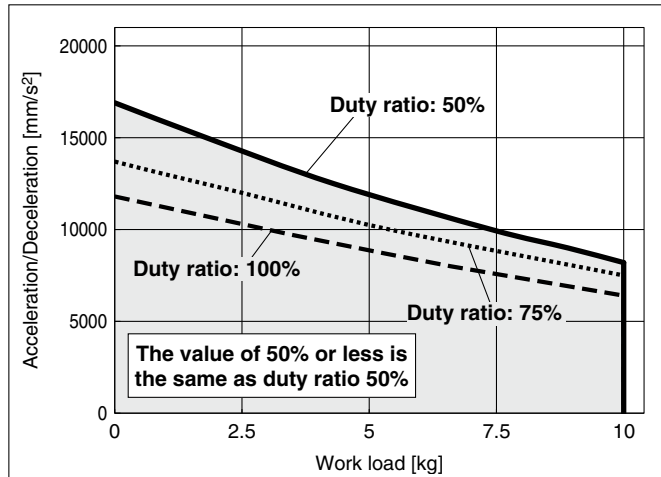

LEJS63□B

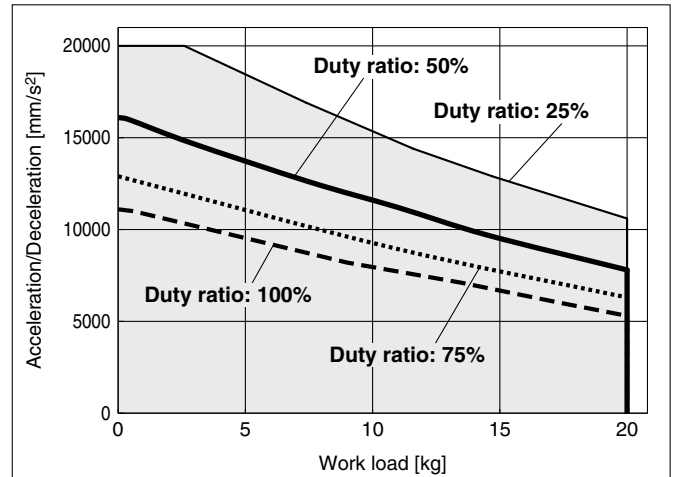

These graphs are examples of when the standard motor is mounted.
Determine the duty ratio after taking into account the load factor of the motor or driver to be used.

* This graph shows the amount of allowable overhang (guide unit) when the center of gravity of the work-piece overhangs in one direction. When selecting the overhang, refer to the "Calculation of Guide Load Factor" or the Electric Actuator Model Selection Software for confirmation: <https://www.smcworld.com>

Dynamic Allowable Moment

Acceleration/Deceleration ——— 1000 mm/s² - - - 3000 mm/s² ——— 5000 mm/s²
 - - - 10000 mm/s² ······ 20000 mm/s²

Orientation	Load overhanging direction m : Work load [kg] Me: Dynamic allowable moment [N·m] L : Overhang to the work load center of gravity [mm]	Model	
		LEJS40	LEJS63
Horizontal	X		
	Y		
	Z		
Bottom	X		
	Y		
	Z		

LEFS
LEFB

LEJS
LEJB

LEL

LEM

LEY
LEYG

LES
LESH

LEPY
LEPS

LER

LEH

LEY-X5

11-LEFS

11-LEJS

25A-

LEC

JXC

LECS
LECS-T

LECY



Motorless

LAT3

* This graph shows the amount of allowable overhang (guide unit) when the center of gravity of the work-piece overhangs in one direction. When selecting the overhang, refer to the "Calculation of Guide Load Factor" or the Electric Actuator Model Selection Software for confirmation: <https://www.smcworld.com>

Dynamic Allowable Moment

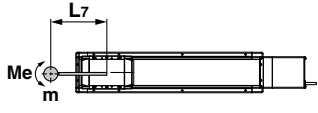
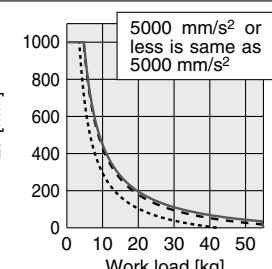
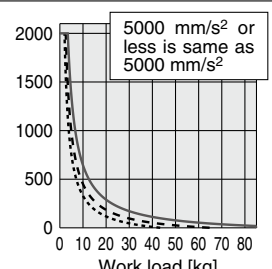
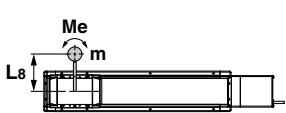
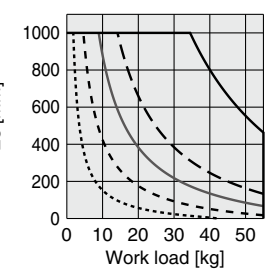
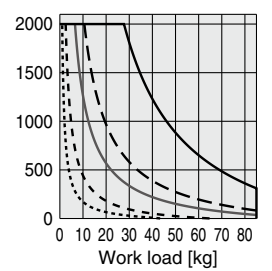
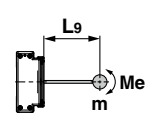
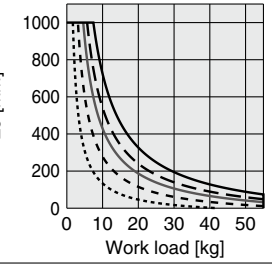
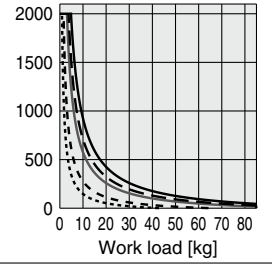
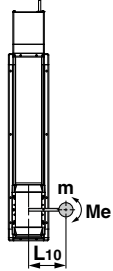
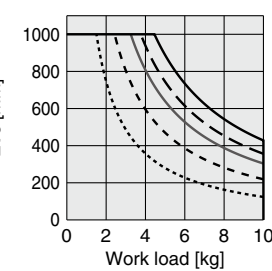
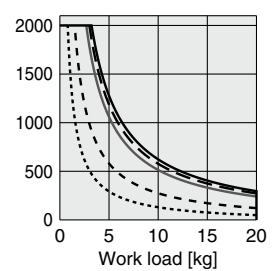
Acceleration/Deceleration ——— 1000 mm/s² - - - 3000 mm/s² ——— 5000 mm/s²
 - - - 10000 mm/s² ······ 20000 mm/s²

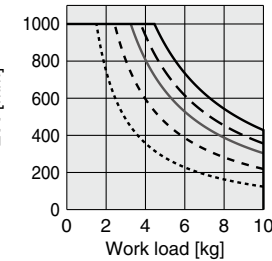
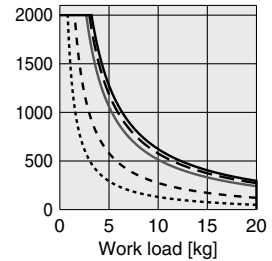
Orientation	Load overhanging direction m : Work load [kg] Me: Dynamic allowable moment [N·m] L : Overhang to the work load center of gravity [mm]	Model	
		LEJS40	LEJS63
Wall	 <p>X</p>		
	 <p>Y</p>		
	 <p>Z</p>		
Vertical	 <p>Y</p>		
	 <p>Z</p>		

Calculation of Guide Load Factor

- Decide operating conditions.

Model: LEJS

Size: 40/63

Mounting orientation: Horizontal/Bottom/Wall/Vertical

Acceleration [mm/s²]: **a**

Work load [kg]: **m**

Work load center position [mm]: **Xc/Yc/Zc**

- Select the target graph while referencing the model, size, and mounting orientation.

- Based on the acceleration and work load, find the overhang [mm]: **Lx/Ly/Lz** from the graph.

- Calculate the load factor for each direction.

$$\alpha_x = Xc/Lx, \alpha_y = Yc/Ly, \alpha_z = Zc/Lz$$

- Confirm the total of α_x , α_y , and α_z is 1 or less.

$$\alpha_x + \alpha_y + \alpha_z \leq 1$$

When 1 is exceeded, consider a reduction of acceleration and work load, or a change of the work load center position and series.

Example

- Operating conditions

Model: LEJS

Size: 40

Mounting orientation: Horizontal

Acceleration [mm/s²]: 5000

Work load [kg]: 20

Work load center position [mm]: **Xc = 0, Yc = 50, Zc = 200**

- Select the graph on page 880, top and left side first row.

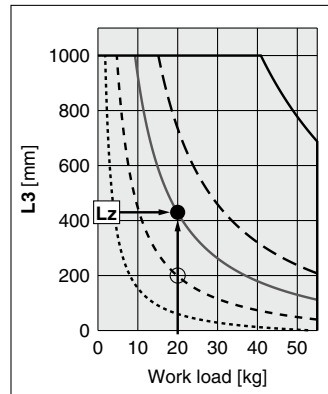
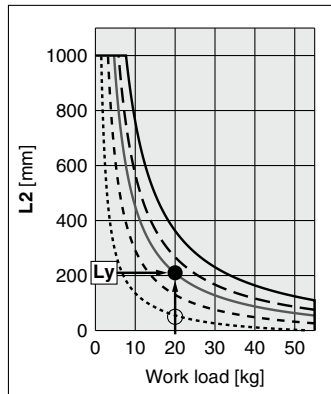
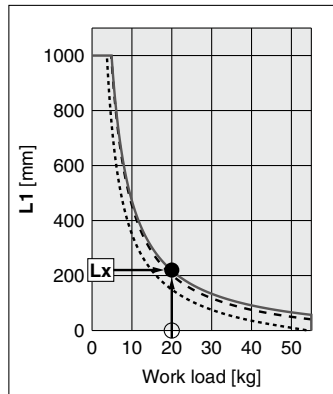

- Lx = 220 mm, Ly = 210 mm, Lz = 430 mm**

- The load factor for each direction can be found as follows.

$$\alpha_x = 0/220 = 0$$

$$\alpha_y = 50/210 = 0.24$$

$$\alpha_z = 200/430 = 0.47$$

- $\alpha_x + \alpha_y + \alpha_z = 0.71 \leq 1$

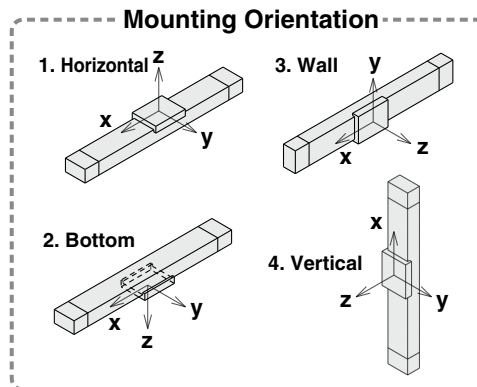

LEFS
LEFB

LEJS
LEJB

LEL

LEM

LEY
LEYG

LES
LESH

LEPY
LEPS

LER

LEH

LEY-X5

11-LEFS

11-LEJS

25A-

LEC

JXC

LECS
LECS-T

LECY

Motorless

LAT3

LEJS Series

Motorless Type

Table Accuracy (Reference Value)

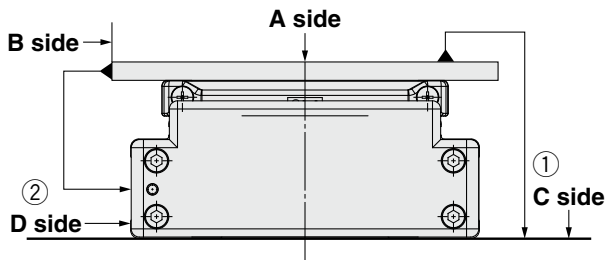

Model	Traveling parallelism [mm] (Every 300 mm)	
	① C side traveling parallelism to A side	② D side traveling parallelism to B side
LEJS40	0.05	0.03
LEJS63	0.05	0.03

* Traveling parallelism does not include the mounting surface accuracy.

Table Displacement (Reference Value)

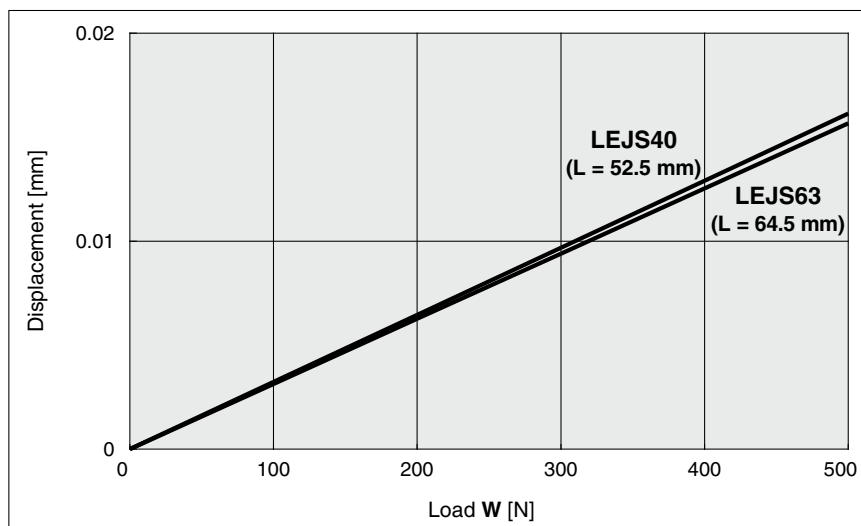
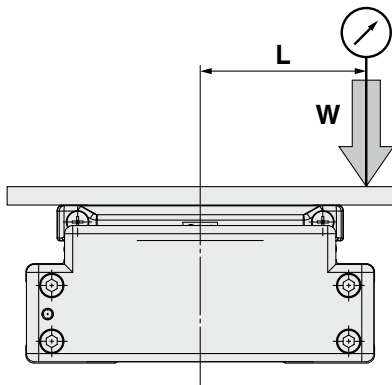

* This displacement is measured when a 15 mm aluminum plate is mounted and fixed on the table. (Table clearance is included.)

LAT3
Motorless
LECY <input type="checkbox"/>
LECS <input type="checkbox"/> LECS-T <input type="checkbox"/>
JXC <input type="checkbox"/>
LEC <input type="checkbox"/>
25A-
11-LEJS
11-LEFS
LEY-X5
LEH
LER
LEPY LEPS
LES LESH
LEY LEYG
LEM
LEL
LEJS LEJB
LEFS LEFB

Electric Actuator/High Rigidity Slider Type Ball Screw Drive

LEJS Series LEJS40, 63



How to Order

LEJS H 40 NZ A - 500

① ② ③ ④ ⑤

① Accuracy

Nil	Basic type
H	High-precision type

② Size

40
63

③ Motor type

Symbol	Type
NZ	Mounting type Z
NY	Mounting type Y
NX	Mounting type X
NW*1	Mounting type W
NV*1	Mounting type V
NU*1	Mounting type U
NT*1	Mounting type T

*1 Size 63 only

④ Lead [mm]

Symbol	LEJS40	LEJS63
H	24	30
A	16	20
B	8	10

⑤ Stroke [mm]

200
to
1500

* For details, refer to the table below.

Applicable Stroke Table

●: Standard

Model	Stroke [mm]	200	300	400	500	600	700	800	900	1000	1200	1500
LEJS40		●	●	●	●	●	●	●	●	●	●	—
LEJS63		—	●	●	●	●	●	●	●	●	●	●

* Please consult with SMC for non-standard strokes as they are produced as special orders.

For auto switches, refer to pages 894 to 897.

Compatible Motors

Applicable motor model			Size/Motor type									
Manufacturer	Series	Type	40			63						
			NZ Mounting type Z	NY Mounting type Y	NX Mounting type X	NZ Mounting type Z	NY Mounting type Y	NX Mounting type X	NW Mounting type W	NV Mounting type V	NU Mounting type U	NT Mounting type T
Mitsubishi Electric Corporation	MELSERVO-JN	HF-KN	●	—	—	●	—	—	—	—	—	—
	MELSERVO-J4	HG-KR	●	—	—	●	—	—	—	—	—	—
	MELSERVO-J5	HK-KT	●	—	—	●	—	—	—	—	—	—
YASKAWA Electric Corporation	Σ-V	SGMJV	●	—	—	●	—	—	—	—	—	—
	Σ-7	SGM7J/SGM7A	●	—	—	●	—	—	—	—	—	—
SANYO DENKI CO., LTD.	SANMOTION R	R2	●	—	—	●	—	—	—	—	—	
OMRON Corporation	Sysmac G5	R88M-K	●	—	—	●	—	—	—	—	—	—
	1 S	R88M-1	●	—	—	●	—	—	—	—	—	—
Panasonic Corporation	MINAS A5	MSM□/MHMD	—	●	—	—	●	—	—	—	—	—
	MINAS A6	MSMF	—	●	—	—	●	—	—	—	—	—
		MHMF	●	—	—	—	●	—	—	—	—	—
FANUC CORPORATION	βis (-B)	β	●	—	—	● (β1 only)	—	—	●	—	—	—
NIDEC SANKYO CORPORATION	S-FLAG	MA/MH/MM	●	—	—	●	—	—	—	—	—	—
KEYENCE CORPORATION	SV	SV-M/SV-B	●	—	—	●	—	—	—	—	—	—
	SV2	SV2-M/SV2-B	●	—	—	●	—	—	—	—	—	—
FUJI ELECTRIC CO., LTD.	ALPHA5	GYS/GYB	●	—	—	●	—	—	—	—	—	—
	ALPHA7	GYS/GYB	●	—	—	●	—	—	—	—	—	—
	FALDIC α	GYS	●	—	—	●	—	—	—	—	—	—
Rockwell Automation, Inc. (Allen-Bradley)	MP-/VP-	MP/VP	—	—	—	—	—	●	—	—	—	—
	TL	TLY-A	●	—	—	—	—	—	—	—	—	●
Beckhoff Automation GmbH	AM	AM30	●	—	—	—	—	—	—	●	—	—
	AM	AM31	●	—	—	—	—	—	—	—	●	—
	AM	AM80/AM81	●	—	—	—	—	●	—	—	—	—
Siemens AG	1FK7	1FK7	—	—	●	—	—	●	—	—	—	
Delta Electronics, Inc.	ASDA-A2	ECMA	●	—	—	●	—	—	—	—	—	
ANCA Motion	AMD2000	Alpha	●	—	—	●	—	—	—	—	—	

Specifications

- Values in this specifications table are the allowable values of the actuator body with the standard motor mounted.
- Do not use the actuator so that it exceeds these values.

Model		LEJS40			LEJS63				
Actuator specifications	Stroke [mm]*1	200, 300, 400, 500, 600, 700, 800 900, 1000, 1200			300, 400, 500, 600, 700, 800, 900 1000, 1200, 1500				
	Work load [kg]*2	Horizontal	15	30	55	30	45	85	
		Vertical	3	5	10	6	10	20	
	Speed*3 [mm/s]	Stroke range	Up to 500	1800	1200	600	1800	1200	600
			501 to 600	1580	1050	520			
			601 to 700	1170	780	390			
			701 to 800	910	600	300	1390	930	460
			801 to 900	720	480	240	1110	740	370
			901 to 1000	580	390	190	900	600	300
			1001 to 1100	480	320	160	750	500	250
			1101 to 1200	410	270	130	630	420	210
			1201 to 1300	—	—	—	540	360	180
	1301 to 1400	—	—	—	470	310	150		
	1401 to 1500	—	—	—	410	270	130		
	Max. acceleration/deceleration [mm/s ²]		20000						
	Positioning repeatability [mm]	Basic type	±0.02						
		High-precision type	±0.01						
	Lost motion [mm]*4	Basic type	0.1 or less						
		High-precision type	0.05 or less						
Ball screw specifications	Thread size [mm]	ø12			ø15				
	Lead [mm]	24	16	8	30	20	10		
	Shaft length [mm]	Stroke + 118.5			Stroke + 126.5				
Impact/Vibration resistance [m/s ²]*5		50/20							
Actuation type		Ball screw							
Guide type		Linear guide							
Operating temperature range [°C]		5 to 40							
Operating humidity range [%RH]		90 or less (No condensation)							
Other *6 specifications	Actuation unit weight [kg]	0.86			1.37				
	Other inertia [kg·cm ²]	0.031			0.129				
	Friction coefficient	0.05							
	Mechanical efficiency	0.8							
Reference motor *7 specifications	Motor shape	□40			□60				
	Motor type	AC servo motor (100 V/200 V)							
	Rated output capacity [W]	100			200				
	Rated torque [N·m]	0.32			0.64				

- *1 Please consult with SMC for non-standard strokes as they are produced as special orders.
 *2 Check the "Speed-Work Load Graph (Guide)" on page 876.
 *3 The allowable speed changes according to the stroke.
 *4 A reference value for correcting an error in reciprocal operation
 *5 Impact resistance: No malfunction occurred when the actuator was tested with a drop tester in both an axial direction and a perpendicular direction to the lead screw. (The test was performed with the actuator in the initial state.)
 Vibration resistance: No malfunction occurred in a test ranging between 45 to 2000 Hz. The test was performed in both an axial direction and a perpendicular direction to the lead screw. (The test was performed with the actuator in the initial state.)
 *6 Each value is only to be used as a guide to select a motor of the appropriate capacity.
 *7 For other specifications, refer to the specifications of the motor that is to be installed.
 * Sensor magnet position is located in the table center.
 For detailed dimensions, refer to the "Auto Switch Mounting Position."
 * Do not allow collisions at either end of the table traveling distance.
 Additionally, when running the positioning operation, do not set within 2 mm of both ends.
 * Please consult with SMC for the manufacture of intermediate strokes.
 (LEJS40/Manufacturable stroke range: 200 to 1200 mm, LEJS63/Manufacturable stroke range: 300 to 1500 mm)

Weight

Model	LEJS40									
Stroke [mm]	200	300	400	500	600	700	800	900	1000	1200
Product weight [kg]	5.0	5.8	6.5	7.3	8.1	8.8	9.6	10.4	11.1	12.7

Model	LEJS63									
Stroke [mm]	300	400	500	600	700	800	900	1000	1200	1500
Product weight [kg]	10.4	11.7	12.9	14.2	15.4	16.7	17.9	19.1	21.6	25.4



LEJS Series

Motorless Type

Refer to the "Motor Mounting" on page 891 for details about motor mounting and included parts.

Dimensions: Ball Screw Drive

LEJS40

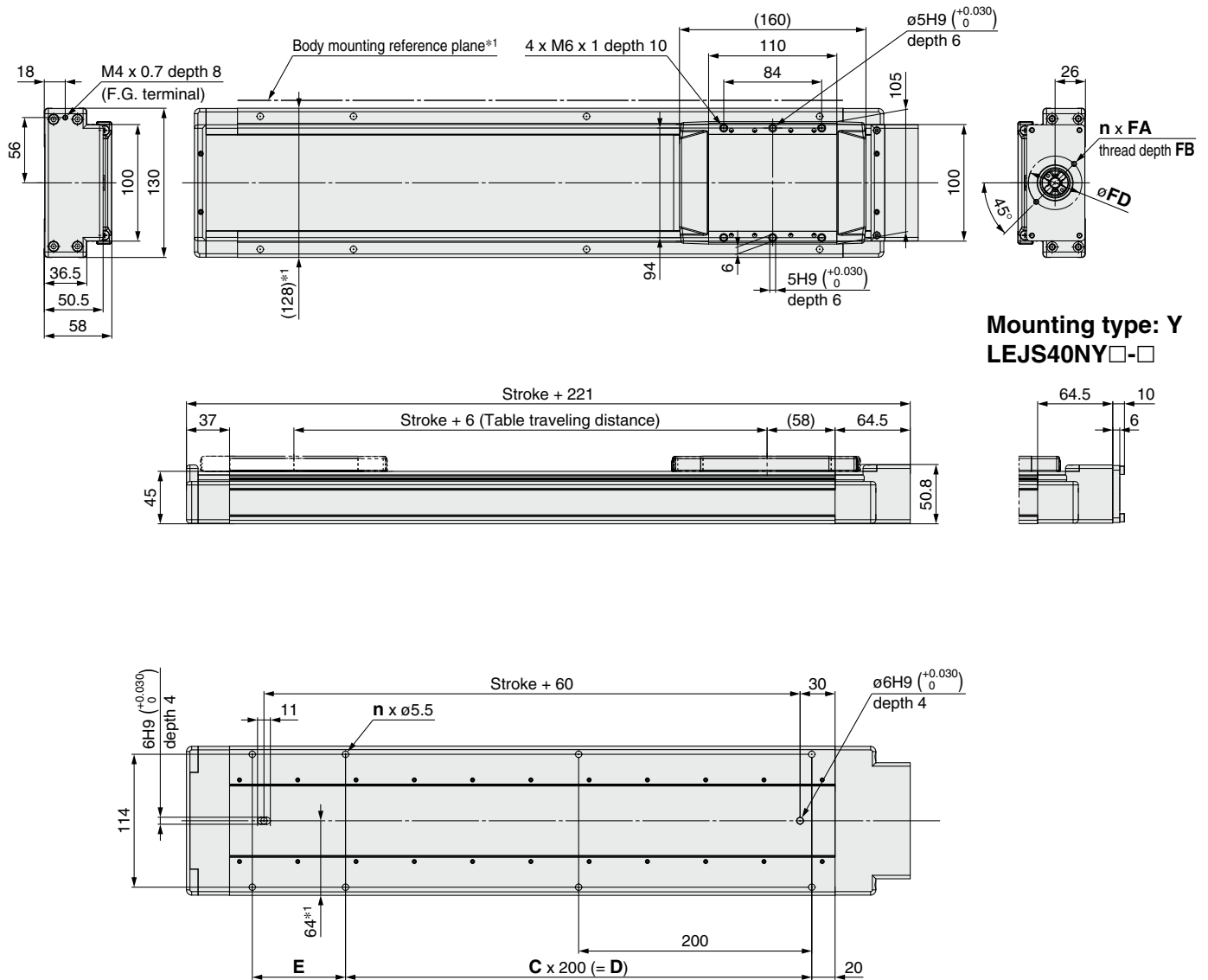

Mounting type: Y
LEJS40NY□-□

*1 When mounting the actuator using the body mounting reference plane, use a pin. Set the height of the pin to be 5 mm or more because of round chamfering. (Recommended height 6 mm)

Dimensions [mm]

Model	n	C	D	E
LEJS40N□□-200	6	1	200	80
LEJS40N□□-300	6	1	200	180
LEJS40N□□-400	8	2	400	80
LEJS40N□□-500	8	2	400	180
LEJS40N□□-600	10	3	600	80
LEJS40N□□-700	10	3	600	180
LEJS40N□□-800	12	4	800	80
LEJS40N□□-900	12	4	800	180
LEJS40N□□-1000	14	5	1000	80
LEJS40N□□-1200	16	6	1200	80

Motor Mounting Dimensions [mm]

Motor type	n	FA	FB	FD
NZ/Mounting type Z	2	M4 x 0.7	7	46
NY/Mounting type Y	4	M3 x 0.5	6	45
NX/Mounting type X	2	M4 x 0.7	7	46

Refer to the "Motor Mounting" on page 891 for details about motor mounting and included parts.

Dimensions: Ball Screw Drive

LEJS63

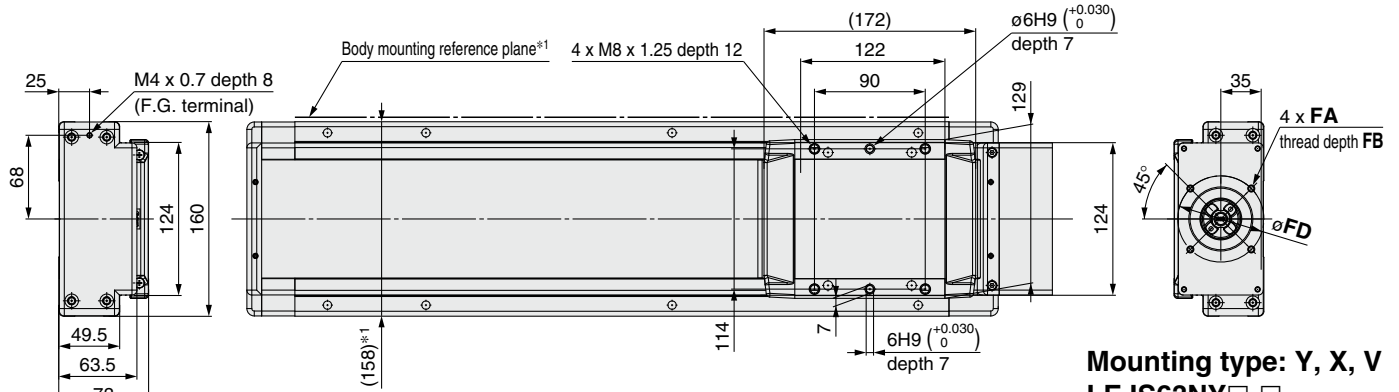

Mounting type: Y, X, V

- LEJS63NY□-□
- LEJS63NX□-□
- LEJS63NV□-□

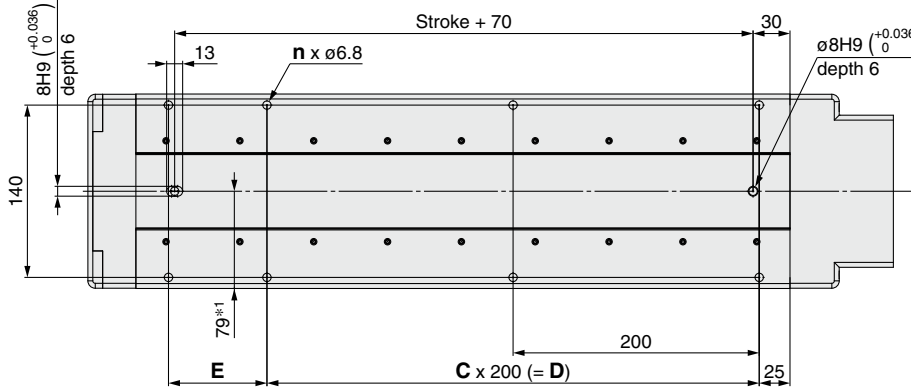
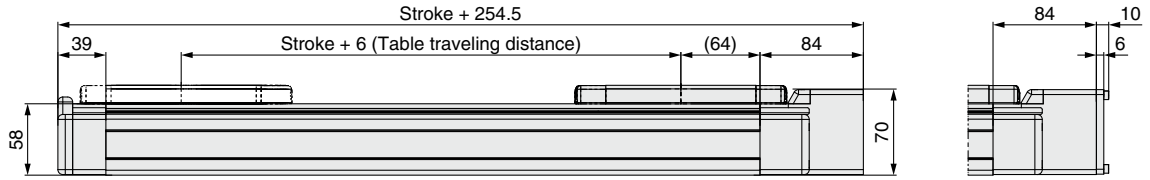

*1 When mounting the actuator using the body mounting reference plane, use a pin. Set the height of the pin to be 5 mm or more because of round chamfering. (Recommended height 6 mm)

Dimensions [mm]

Model	n	C	D	E
LEJS63N□□-300	6	1	200	180
LEJS63N□□-400	8	2	400	80
LEJS63N□□-500	8	2	400	180
LEJS63N□□-600	10	3	600	80
LEJS63N□□-700	10	3	600	180
LEJS63N□□-800	12	4	800	80
LEJS63N□□-900	12	4	800	180
LEJS63N□□-1000	14	5	1000	80
LEJS63N□□-1200	16	6	1200	80
LEJS63N□□-1500	18	7	1400	180

Motor Mounting Dimensions [mm]

Motor type	FA	FB	FD
NZ/Mounting type Z	M5 x 0.8	7	70
NY/Mounting type Y	M4 x 0.7	6	70
NX/Mounting type X	M5 x 0.8	6	63
NW/Mounting type W	M5 x 0.8	7	70
NV/Mounting type V	M4 x 0.7	6	63
NU/Mounting type U	M5 x 0.8	7	70
NT/Mounting type T	M5 x 0.8	7	70

- LEFS
- LEFB
- LEJS
- LEJB
- LEL
- LEM
- LEY
- LEYG
- LES
- LESH
- LEPY
- LEPS
- LER
- LEH
- LEY-X5
- 11-LEFS
- 11-LEJS
- 25A-
- LEC□
- JXC□
- LECS□
- LECS□-T
- LECY□
- Motorless
- LAT3

Built-in Intermediate Supports Type

These specifications enable the maximum speed to be realized throughout the entire stroke.

Electric Actuator/High Rigidity Slider Type Ball Screw Drive

LEJS63□-□M Series

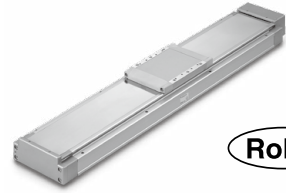

Standard LEJS Series ▶ p. 885

How to Order

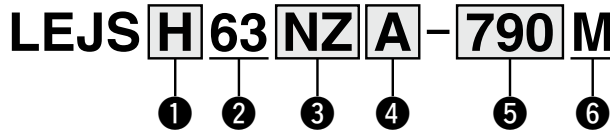

1 Accuracy

Nil	Basic type
H	High-precision type

2 Size

63

3 Motor type

NZ	Mounting type Z
NY	Mounting type Y
NX	Mounting type X
NW	Mounting type W
NV	Mounting type V
NU	Mounting type U
NT	Mounting type T

4 Lead [mm]

H	30
A	20
B	10

5 Stroke [mm]*1

●Standard ○Produced upon receipt of order

790	890	990	1190	1490	1790
●	●	○	○	○	○

*1 Please consult with SMC for non-standard strokes as they are produced as special orders.

6 Built-in intermediate supports

M	Built-in intermediate supports
---	--------------------------------

Specifications

Lead [mm]		30	20	10	
Speed [mm/s]	Stroke range	790	1800	1200	600
		890			
		990			
		1190			
		1490			
1790					

For the model selection method, refer to page 875. Specifications other than those listed are the same as the standard product. Refer to page 886 for details. For details on the construction, refer to page 194.

For auto switches, refer to pages 894 to 897.

Compatible Motors

Applicable motor model			Size/Motor type						
Manufacturer	Series	Type	63						
			NZ Mounting type Z	NY Mounting type Y	NX Mounting type X	NW Mounting type W	NV Mounting type V	NU Mounting type U	NT Mounting type T
Mitsubishi Electric Corporation	MELSERVO-JN	HF-KN	●	—	—	—	—	—	—
	MELSERVO-J4	HG-KR	●	—	—	—	—	—	—
	MELSERVO-J5	HK-KT	●	—	—	—	—	—	—
YASKAWA Electric Corporation	Σ-V	SGMJV	●	—	—	—	—	—	—
	Σ-7	SGM7J/SGM7A	●	—	—	—	—	—	—
SANYO DENKI CO., LTD.	SANMOTION R	R2	●	—	—	—	—	—	—
OMRON Corporation	Sysmac G5	R88M-K	—	●	—	—	—	—	—
	1 S	R88M-1	—	●	—	—	—	—	—
Panasonic Corporation	MINAS A5	MSM□/MHMD	—	●	—	—	—	—	—
	MINAS A6	MSMF/MHMF	—	●	—	—	—	—	—
FANUC CORPORATION	βis (-B)	β	● (β1 only)	—	—	●	—	—	—
NIDEC SANKYO CORPORATION	S-FLAG	MA/MH/MM	●	—	—	—	—	—	—
KEYENCE CORPORATION	SV	SV-M/SV-B	●	—	—	—	—	—	—
	SV2	SV2-M/SV2-B	●	—	—	—	—	—	—
FUJI ELECTRIC CO., LTD.	ALPHA5	GYS/GYB	●	—	—	—	—	—	—
	ALPHA7	GYS/GYB	●	—	—	—	—	—	—
	FALDIC α	GYS	●	—	—	—	—	—	—
Rockwell Automation, Inc. (Allen-Bradley)	MP-/VP-	MP/VP	—	—	●	—	—	—	—
	TL	TLY-A	—	—	—	—	—	—	●
Beckhoff Automation GmbH	AM	AM30	—	—	—	—	●	—	—
	AM	AM31	—	—	—	—	—	●	—
	AM	AM80/AM81	—	—	●	—	—	—	—
Siemens AG	1FK7	1FK7	—	—	●	—	—	—	—
Delta Electronics, Inc.	ASDA-A2	ECMA	●	—	—	—	—	—	—
ANCA Motion	AMD2000	Alpha	●	—	—	—	—	—	—

The motor mounting method and the included parts are the same as the standard product. Refer to page 891 for details.

Dimensions: Ball Screw Drive

Motorless

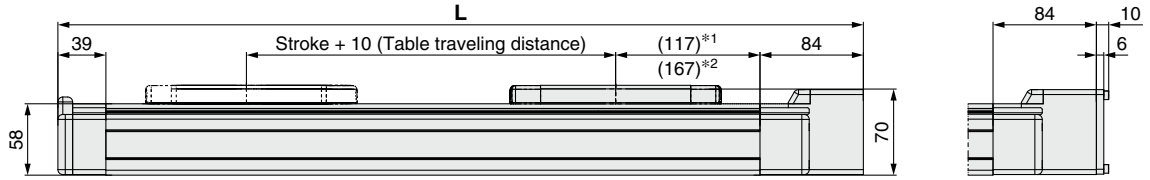
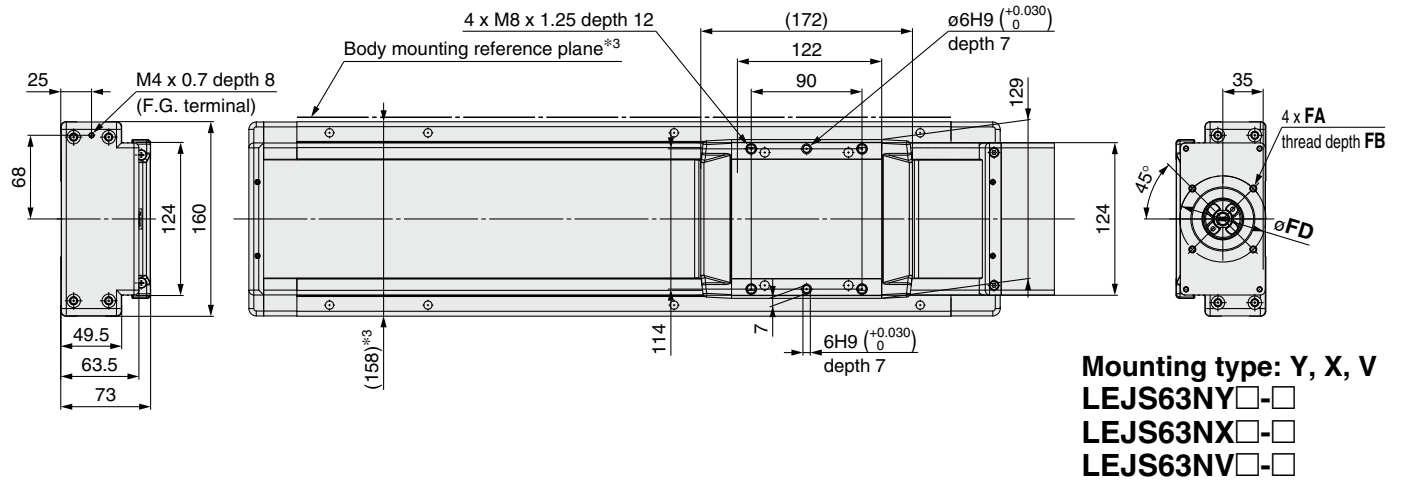

*1 Upper dimension: 790 to 1190 mm stroke
 *2 Lower dimension: 1490 to 1790 mm stroke

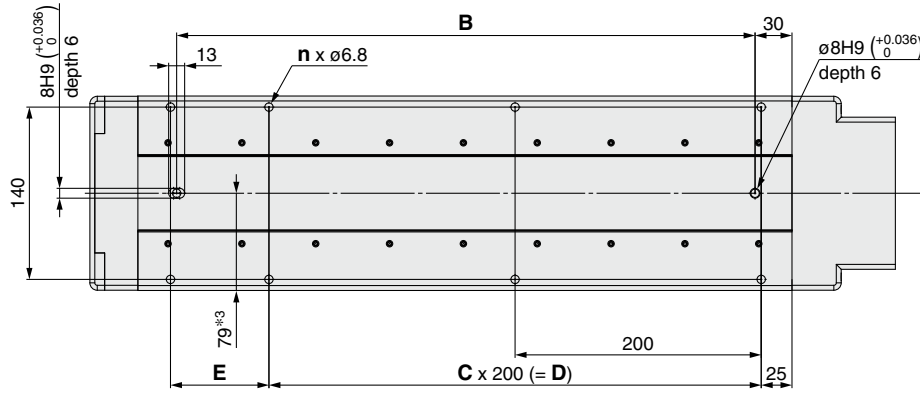

*3 When mounting the actuator using the body mounting reference plane, use a pin. Set the height of the pin to be 5 mm or more because of round chamfering. (Recommended height 6 mm)

⚠ Caution

1. During operation, the intermediate support mechanism emits a collision noise due to the structure.
2. Compared to the standard product, the entire length of the product will be longer for each stroke. For details, refer to the dimensions.
3. The stopper type origin position return method cannot be used as the return to origin method (due to the bumper as shown in Construction ④ on page 194).

Dimensions and Weight

Model	L	B	n	C	D	E	Product weight [kg]
LEJS□63N□□-790M	1154.5	970	12	4	800	180	18.4
LEJS□63N□□-890M	1254.5	1070	14	5	1000	80	19.7
LEJS□63N□□-990M	1354.5	1170	14	5	1000	180	20.9
LEJS□63N□□-1190M	1554.5	1370	16	6	1200	180	23.4
LEJS□63N□□-1490M	1954.5	1770	20	8	1600	180	28.9
LEJS□63N□□-1790M	2254.5	2070	24	10	2000	80	32.7

Motor Mounting Dimensions

Motor type	FA	FB	FD
NZ/Mounting type Z	M5 x 0.8	7	70
NY/Mounting type Y	M4 x 0.7	6	70
NX/Mounting type X	M5 x 0.8	6	63
NW/Mounting type W	M5 x 0.8	7	70
NV/Mounting type V	M4 x 0.7	6	63
NU/Mounting type U	M5 x 0.8	7	70
NT/Mounting type T	M5 x 0.8	7	70

LEFS
LEFB
LEJS
LEJB
LEL
LEM
LEMY
LEYG
LES
LESH
LEPY
LEPS
LER
LEH
LEY-X5
11-LEFS
11-LEJS
25A-
LEC□
JXC□
LECS□
LECS□-T
LECY□
Motorless
LAT3

LEJS Series

Motorless Type

- When mounting a hub, remove all oil content, dust, and dirt adhered to the shaft and the inside of the hub.
- This product does not include the motor and motor mounting screws. (Provided by the customer)
Prepare a motor with a round shaft end.
- Take measures to prevent the loosening of the motor mounting screws.

Motor Mounting

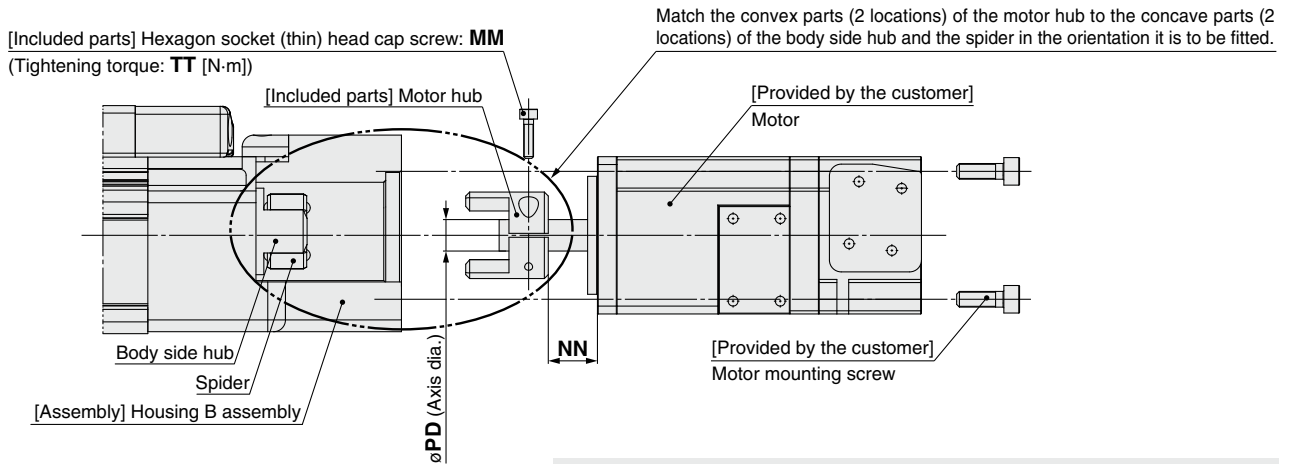

Mounting procedure

- 1) Secure the motor hub to the motor (provided by the customer) with the MM hexagon socket head cap screw.
- 2) Check the motor hub position, and then insert it.
- 3) Secure the motor to the housing B assembly with the motor mounting screws (provided by the customer).

Dimensions

Size	Motor type	MM	TT	NN	PD
40	NZ/Mounting type Z	M2.5 x 10	0.65	12.5	8
	NY/Mounting type Y	M2.5 x 10	0.65	12.5	8
	NX/Mounting type X	M2.5 x 10	0.65	7	8
63	NZ/Mounting type Z	M3 x 12	1.5	18	14
	NY/Mounting type Y	M4 x 12	2.7	18	11
	NX/Mounting type X	M4 x 12	2.7	8	9
	NW/Mounting type W	M4 x 12	2.7	12	9
	NV/Mounting type V	M4 x 12	2.7	8	9
	NU/Mounting type U	M4 x 12	2.7	12	11
	NT/Mounting type T	M3 x 12	1.5	18	12

Included Parts List

Size: 40

Description	Quantity	Note
Motor hub	1	—
Hexagon socket head cap screw (to secure the hub)	1	M2.5 x 10: Motor type "NZ," "NY," "NX"

Size: 63

Description	Quantity	Note
Motor hub	1	—
Hexagon socket head cap screw (to secure the hub)	1	M3 x 12: Motor type "NZ," "NT"
Hexagon socket thin head cap screw (to secure the hub)		M4 x 12: Motor type "NY," "NX," "NW," "NV," "NU"

LEJS Series Motor Mounting Parts

Motor Flange Option

As the motor type "NZ" is selected for the model and this option is mounted, the motor types that can be used are shown below.

How to Order

LEJ-MF **63** D-**NY**

①

②

① Size

40	For LEJ40
63	For LEJ63

② Motor type

Symbol	Type
NY	Mounting type Y
NX	Mounting type X
NW	Mounting type W
NV	Mounting type V
NU	Mounting type U
NT	Mounting type T

* Component parts vary depending on the motor type. Refer to the "Component Parts" on page 893.

Compatible Motors

Applicable motor model			Size/Motor type									
Manufacturer	Series	Type	40			63						
			NZ Mounting type Z	NY Mounting type Y	NX Mounting type X	NZ Mounting type Z	NY Mounting type Y	NX Mounting type X	NW Mounting type W	NV Mounting type V	NU Mounting type U	NT Mounting type T
Mitsubishi Electric Corporation	MELSERVO-JN	HF-KN	●	—	—	●	—	—	—	—	—	—
	MELSERVO-J4	HG-KR	●	—	—	●	—	—	—	—	—	—
	MELSERVO-J5	HK-KT	●	—	—	●	—	—	—	—	—	—
YASKAWA Electric Corporation	Σ-V	SGMJV	●	—	—	●	—	—	—	—	—	—
	Σ-7	SGM7J/SGM7A	●	—	—	●	—	—	—	—	—	—
SANYO DENKI CO., LTD.	SANMOTION R	R2	●	—	—	●	—	—	—	—	—	—
OMRON Corporation	Sysmac G5	R88M-K	●	—	—	—	●	—	—	—	—	—
	1 S	R88M-1	●	—	—	—	●	—	—	—	—	—
Panasonic Corporation	MINAS A5	MSM□/MHMD	—	●	—	—	●	—	—	—	—	—
		MSMF	—	●	—	—	●	—	—	—	—	—
	MINAS A6	MHMF	●	—	—	—	●	—	—	—	—	—
FANUC CORPORATION	βis (-B)	β	●	—	—	● (β1 only)	—	—	●	—	—	—
NIDEC SANKYO CORPORATION	S-FLAG	MA/MH/MM	●	—	—	●	—	—	—	—	—	—
KEYENCE CORPORATION	SV	SV-M/SV-B	●	—	—	●	—	—	—	—	—	—
	SV2	SV2-M/SV2-B	●	—	—	●	—	—	—	—	—	—
FUJI ELECTRIC CO., LTD.	ALPHA5	GYS/GYB	●	—	—	●	—	—	—	—	—	—
	ALPHA7	GYS/GYB	●	—	—	●	—	—	—	—	—	—
	FALDIC α	GYS	●	—	—	●	—	—	—	—	—	—
Rockwell Automation, Inc. (Allen-Bradley)	MP-/VP-	MP/VP	—	—	—	—	—	●	—	—	—	—
	TL	TLY-A	●	—	—	—	—	—	—	—	—	●
Beckhoff Automation GmbH	AM	AM30	●	—	—	—	—	—	—	●	—	—
	AM	AM31	●	—	—	—	—	—	—	—	●	—
	AM	AM80/AM81	●	—	—	—	—	—	●	—	—	—
Siemens AG	1FK7	1FK7	—	—	●	—	—	●	—	—	—	—
Delta Electronics, Inc.	ASDA-A2	ECMA	●	—	—	●	—	—	—	—	—	—
ANCA Motion	AMD2000	Alpha	●	—	—	●	—	—	—	—	—	—

LEFS
LEFB

LEJS
LEJB

LEL

LEM

LEY
LEYG

LES
LESH

LEPY
LEPS

LER

LEH

LEY-X5

11-LEFS

11-LEJS

25A-

LEC□

JXC□

LECS□
LECS□-T

LECY□

Motor/less

LAT3

LEJS Series

Motorless Type

Dimensions: Motor Flange Option

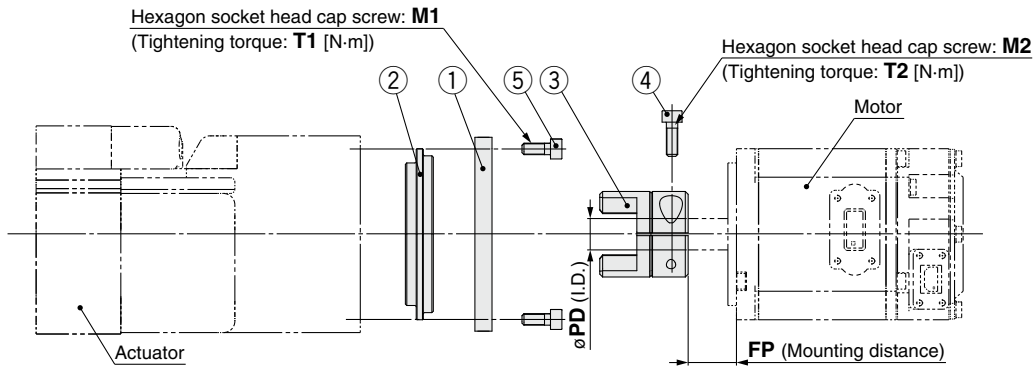

Motor plate details

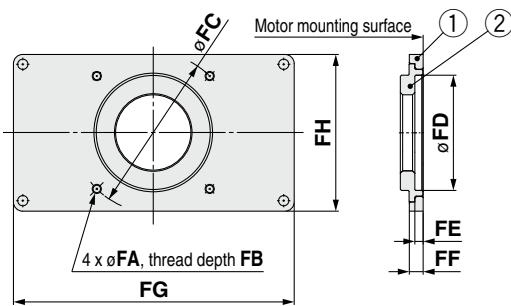

Dimensions

Size	Motor type	FA	FB	FC	FD	FE	FF	FG	FH	M1	T1	M2	T2	PD	FP
40	NY	M3 x 0.5	6	45	30	3.5	6	99	49	M4 x 12	2.7	M2.5 x 10	0.65	8	12.5
	NX	—	—	—	—	—	—	—	—	—	—	M2.5 x 10	0.65	8	7
63	NY	M4 x 0.7	6	70	50	3.5	6	123	68	M4 x 12	2.7	M4 x 12	2.7	11	18
	NX	M5 x 0.8	6	63	40	3.5	6	123	68	M4 x 12	2.7	M4 x 12	2.7	9	8
	NW	—	—	—	—	—	—	—	—	—	—	M4 x 12	2.7	9	12
	NV	M4 x 0.7	6	63	40	3.5	6	123	68	M4 x 12	2.7	M4 x 12	2.7	9	8
	NU	—	—	—	—	—	—	—	—	—	—	M4 x 12	2.7	11	12
	NT	—	—	—	—	—	—	—	—	—	—	M3 x 12	1.5	12	18

Component Parts

Size: 40

No.	Description	Quantity	
		Motor type	
		NY	NX
1	Motor plate	1	—
2	Ring	1	—
3	Hub (Motor side)	1	1
4	Hexagon socket thin head cap screw	1	1
5	Hexagon socket head cap screw	4	—

Size: 63

No.	Description	Quantity					
		Motor type					
		NY	NX	NW	NV	NU	NT
1	Motor plate	1	1	—	1	—	—
2	Ring	1	1	—	1	—	—
3	Hub (Motor side)	1	1	1	1	1	1
4	Hexagon socket thin head cap screw	1	1	1	1	1	1
5	Hexagon socket head cap screw	4	4	—	4	—	—

LEJS Series Auto Switch Mounting

Auto Switch Mounting Position

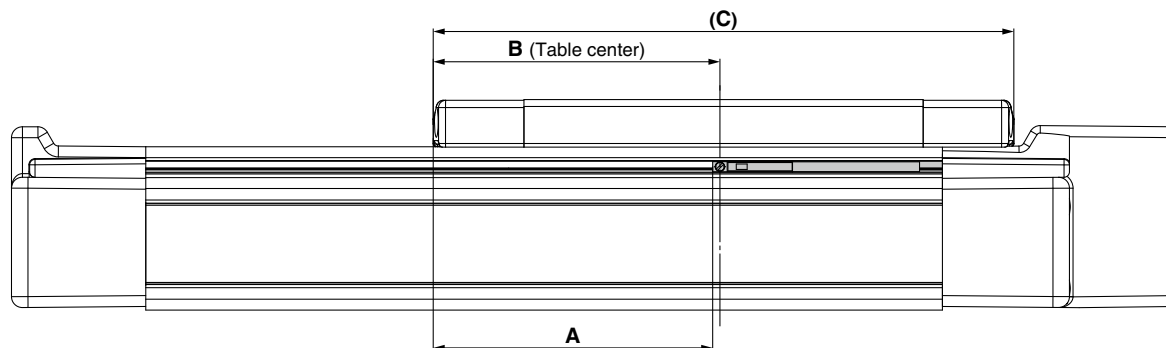

[mm]					
Model	Size	A	B	C	Operating range
LEJS	40	77	80	160	5.5
	63	83	86	172	7.0

* Since the operating range is provided as a guideline including hysteresis, it cannot be guaranteed (assuming approximately $\pm 30\%$ dispersion). It may change substantially depending on the ambient environment.

Auto Switch Mounting

When mounting the auto switches, they should be inserted into the actuator's auto switch mounting groove as shown in the drawing below. After setting in the mounting position, use a flat head watchmaker's screwdriver to tighten the auto switch mounting screw that is included.

Auto Switch Mounting Screw Tightening Torque [N·m]

Auto switch model	Tightening torque
D-M9□(V) D-M9□W(V)	0.10 to 0.15

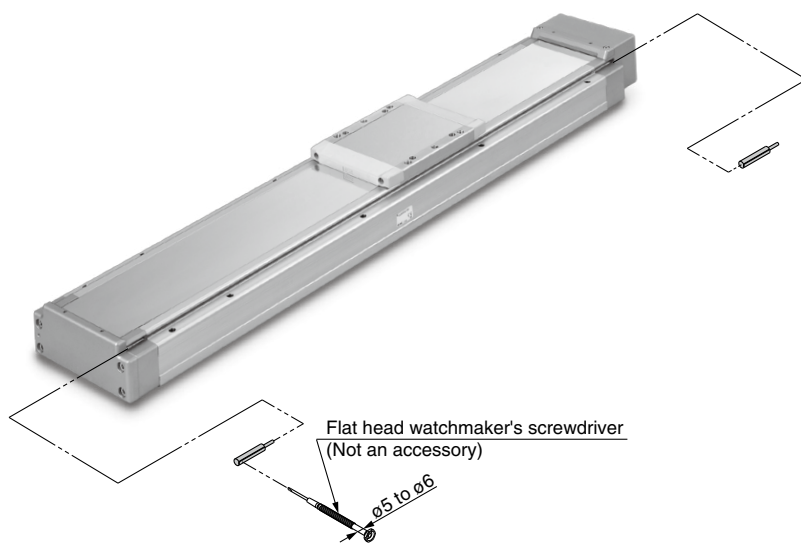

* When tightening the auto switch mounting screw (included with auto switch), use a watchmaker's screwdriver with a handle diameter of about 5 to 6 mm.

LEFS
LEFBLEJS
LEJB

LEL

LEM

LEY
LEYGLES
LESHLEPY
LEPS

LER

LEH

LEY-X5

11-LEFS

11-LEJS

25A-

LEC□

JXC□

LECS□
LECS□-T

LECY□

Motorless

LAT3

Solid State Auto Switch Direct Mounting Type D-M9N(V)/D-M9P(V)/D-M9B(V)



Refer to the SMC website for details on products that are compliant with international standards.

Grommet

- 2-wire load current is reduced (2.5 to 40 mA).
- Using flexible cable as standard spec.



Caution

Precautions

Fix the auto switch with the existing screw installed on the auto switch body. The auto switch may be damaged if a screw other than the one supplied is used.

Auto Switch Specifications

PLC: Programmable Logic Controller

D-M9□, D-M9□V (With indicator light)						
Auto switch model	D-M9N	D-M9NV	D-M9P	D-M9PV	D-M9B	D-M9BV
Electrical entry direction	In-line	Perpendicular	In-line	Perpendicular	In-line	Perpendicular
Wiring type	3-wire				2-wire	
Output type	NPN		PNP		—	
Applicable load	IC circuit, Relay, PLC				24 VDC relay, PLC	
Power supply voltage	5, 12, 24 VDC (4.5 to 28 V)				—	
Current consumption	10 mA or less				—	
Load voltage	28 VDC or less		—		24 VDC (10 to 28 VDC)	
Load current	40 mA or less				2.5 to 40 mA	
Internal voltage drop	0.8 V or less at 10 mA (2 V or less at 40 mA)				4 V or less	
Leakage current	100 μA or less at 24 VDC				0.8 mA or less	
Indicator light	Red LED illuminates when turned ON.					
Standard	CE marking, RoHS					

Oilproof Heavy-duty Lead Wire Specifications

Auto switch model		D-M9N(V)	D-M9P(V)	D-M9B(V)
Sheath	Outside diameter [mm]	2.6		
Insulator	Number of cores	3 cores (Brown/Blue/Black)		2 cores (Brown/Blue)
	Outside diameter [mm]	0.88		
Conductor	Effective area [mm ²]	0.15		
	Strand diameter [mm]	0.05		
Minimum bending radius [mm] (Reference values)		17		

- * Refer to page 996 for solid state auto switch common specifications.
- * Refer to page 996 for lead wire lengths.

Weight

[g]

Auto switch model		D-M9N(V)	D-M9P(V)	D-M9B(V)
Lead wire length	0.5 m (Nil)	8	7	7
	1 m (M)	14	13	13
	3 m (L)	41	38	38
	5 m (Z)	68	63	63

Dimensions

[mm]

D-M9□

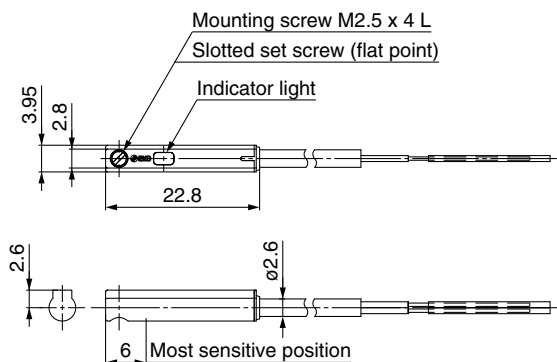

D-M9□V

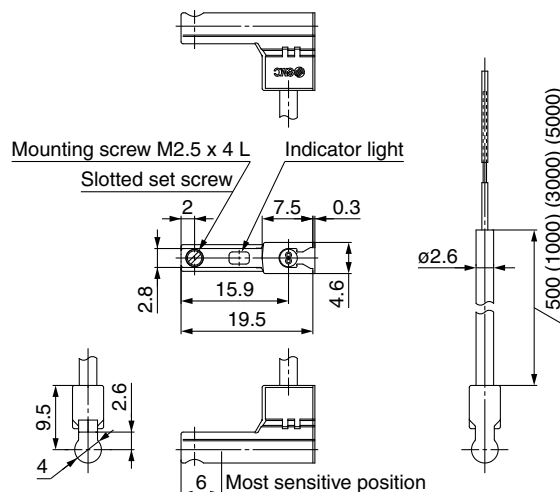

Normally Closed Solid State Auto Switch Direct Mounting Type D-M9NE(V)/D-M9PE(V)/D-M9BE(V)

Refer to the SMC website for details on products that are compliant with international standards.

PLC: Programmable Logic Controller

Grommet

- Output signal turns on when no magnetic force is detected.
- Can be used for the actuator adopted by the solid state auto switch D-M9 series (excluding special order products)



Caution

Precautions

Fix the auto switch with the existing screw installed on the auto switch body. The auto switch may be damaged if a screw other than the one supplied is used.

Auto Switch Specifications

D-M9□E, D-M9□EV (With indicator light)						
Auto switch model	D-M9NE	D-M9NEV	D-M9PE	D-M9PEV	D-M9BE	D-M9BEV
Electrical entry direction	In-line	Perpendicular	In-line	Perpendicular	In-line	Perpendicular
Wiring type	3-wire				2-wire	
Output type	NPN		PNP		—	
Applicable load	IC circuit, Relay, PLC				24 VDC relay, PLC	
Power supply voltage	5, 12, 24 VDC (4.5 to 28 V)				—	
Current consumption	10 mA or less				—	
Load voltage	28 VDC or less		—		24 VDC (10 to 28 VDC)	
Load current	40 mA or less				2.5 to 40 mA	
Internal voltage drop	0.8 V or less at 10 mA (2 V or less at 40 mA)				4 V or less	
Leakage current	100 μA or less at 24 VDC				0.8 mA or less	
Indicator light	Red LED illuminates when turned ON.					
Standard	CE marking, RoHS					

Oilproof Heavy-duty Lead Wire Specifications

Auto switch model	D-M9NE(V)	D-M9PE(V)	D-M9BE(V)
Sheath	Outside diameter [mm]		
	2.6		
Insulator	Number of cores		2 cores (Brown/Blue)
	Outside diameter [mm]		0.88
Conductor	Effective area [mm ²]		0.15
	Strand diameter [mm]		0.05
Minimum bending radius [mm] (Reference values)			
17			

- * Refer to page 996 for solid state auto switch common specifications.
- * Refer to page 996 for lead wire lengths.

Weight

Auto switch model	D-M9NE(V)	D-M9PE(V)	D-M9BE(V)
Lead wire length	0.5 m (Nil)	8	7
	1 m (M)*1	14	13
	3 m (L)	41	38
	5 m (Z)*1	68	63

*1 The 1 m and 5 m options are produced upon receipt of order.

Dimensions

D-M9□E

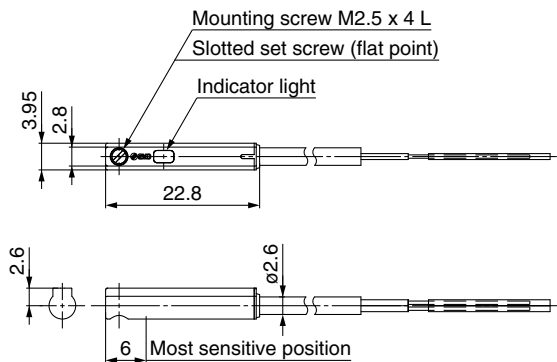

D-M9□EV

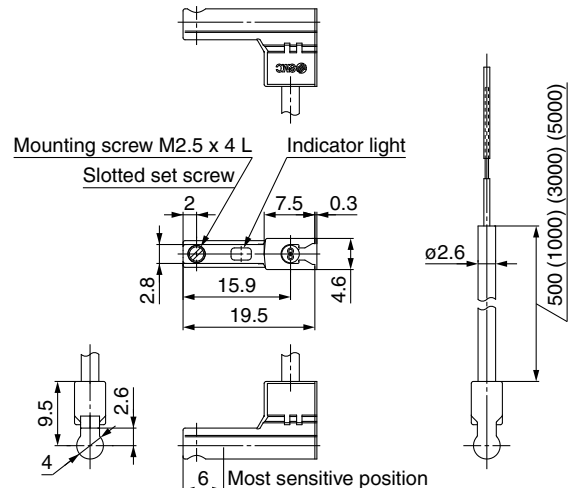

LEFS
LEFB

LEJS
LEJB

LEL

LEM

LEY
LEYG

LES
LESH

LEPY
LEPS

LER

LEH

LEY-X5

11-LEFS

11-LEJS

25A-

LEC□

JXC□

LECS□
LECS□-T

LECY□

Motor/less

LAT3

2-Color Indicator Solid State Auto Switch Direct Mounting Type

D-M9NW(V)/D-M9PW(V)/D-M9BW(V)



Refer to the SMC website for details on products that are compliant with international standards.

Grommet

- 2-wire load current is reduced (2.5 to 40 mA).
- Using flexible cable as standard spec.
- The proper operating range can be determined by the color of the light. (Red → Green ← Red)



Caution

Precautions

Fix the auto switch with the existing screw installed on the auto switch body. The auto switch may be damaged if a screw other than the one supplied is used.

Auto Switch Specifications

PLC: Programmable Logic Controller

D-M9□W, D-M9□WV (With indicator light)						
Auto switch model	D-M9NW	D-M9NWV	D-M9PW	D-M9PWV	D-M9BW	D-M9BWV
Electrical entry direction	In-line	Perpendicular	In-line	Perpendicular	In-line	Perpendicular
Wiring type	3-wire				2-wire	
Output type	NPN		PNP		—	
Applicable load	IC circuit, Relay, PLC				24 VDC relay, PLC	
Power supply voltage	5, 12, 24 VDC (4.5 to 28 V)				—	
Current consumption	10 mA or less				—	
Load voltage	28 VDC or less		—		24 VDC (10 to 28 VDC)	
Load current	40 mA or less				2.5 to 40 mA	
Internal voltage drop	0.8 V or less at 10 mA (2 V or less at 40 mA)				4 V or less	
Leakage current	100 μA or less at 24 VDC				0.8 mA or less	
Indicator light	Operating range Red LED illuminates. Proper operating range Green LED illuminates.					
Standard	CE marking, RoHS					

Oilproof Flexible Heavy-duty Lead Wire Specifications

Auto switch model		D-M9NW(V)	D-M9PW(V)	D-M9BW(V)
Sheath	Outside diameter [mm]	2.6		
Insulator	Number of cores	3 cores (Brown/Blue/Black)		2 cores (Brown/Blue)
	Outside diameter [mm]	0.88		
Conductor	Effective area [mm ²]	0.15		
	Strand diameter [mm]	0.05		
Minimum bending radius [mm] (Reference values)		17		

- * Refer to page 996 for solid state auto switch common specifications.
- * Refer to page 996 for lead wire lengths.

Weight

[g]

Auto switch model		D-M9NW(V)	D-M9PW(V)	D-M9BW(V)
Lead wire length	0.5 m (Nil)	8	7	7
	1 m (M)	14	13	13
	3 m (L)	41	38	38
	5 m (Z)	68	63	63

Dimensions

[mm]

D-M9□W

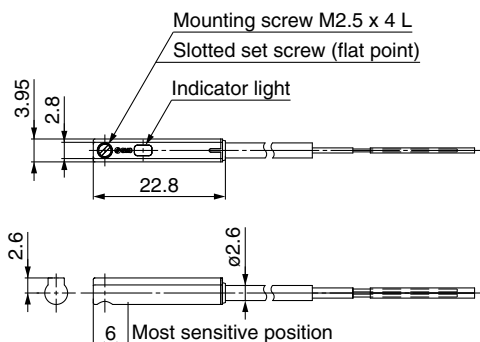

D-M9□WV

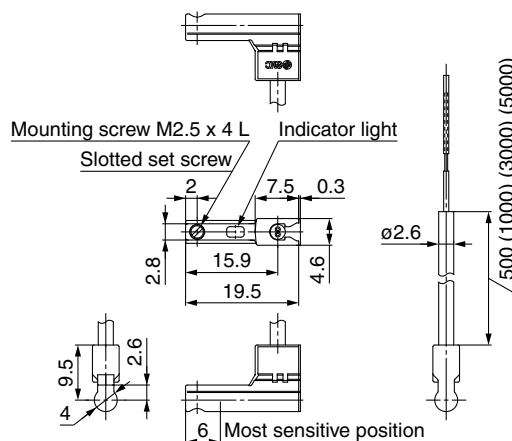



LEJS Series Specific Product Precautions 1

Be sure to read this before handling the products. Refer to page 984 for safety instructions, pages 985 to 990 for electric actuator precautions, and pages 991 to 1000 for auto switch precautions.

Design

⚠ Caution

1. Do not apply a load in excess of the specification limits.

Select a suitable actuator by work load and allowable moment. If a load in excess of the specification limits is applied to the guide, adverse effects such as the generation of play in the guide, reduced accuracy, or reduced service life of the product may occur.

2. Do not use the product in applications where excessive external force or impact force is applied to it.

The product can be damaged. The components including the motor are manufactured to precise tolerances. So that even a slight deformation may cause a malfunction or seizure.

Selection

⚠ Warning

1. Do not increase the speed in excess of the specification limits.

Select a suitable actuator by the relationship of the allowable work load and speed, and the allowable speed of each stroke. If the product is used outside of the specification limits, adverse effects such as the generation of noise, reduced accuracy, or reduced service life of the product may occur.

2. When the product repeatedly cycles with partial strokes (100 mm or less), lubrication can run out. Operate it at a full stroke at least once a day or every a thousand cycles.

3. When external force is to be applied to the table, it is necessary to add the external force to the work load as the total carried load when selecting a size.

When a cable duct or flexible moving tube is attached to the actuator, the sliding resistance of the table will increase, which may lead to the malfunction of the product.

4. Depending on the shape of the motor to be mounted, some of the product's interior parts (hub, spider, etc.) may be visible from the motor mounting surface. If this is undesirable, please contact your nearest sales office for details on options such as covers.

Handling

⚠ Caution

1. Never allow the table to collide with the end of stroke.

When the driver parameters, origin or programs are set incorrectly, the table may collide with the stroke end of the actuator during operation. Be sure to check these points before use.

If the table collides with the stroke end of the actuator, the guide, ball screw, belt, or internal stopper may break. This can result in abnormal operation.



Handle the actuator with care when it is used in the vertical direction as the workpiece will fall freely from its own weight.

2. The actual speed of this actuator is affected by the work load and stroke.

Check the model selection section of the catalog.

3. Do not apply a load, impact, or resistance in addition to the transferred load during return to origin.

4. Do not dent, scratch, or cause other damage to the body or table mounting surfaces.

Doing so may cause unevenness in the mounting surface, play in the guide, or an increase in the sliding resistance.

5. Do not apply strong impact or an excessive moment while mounting the product or a workpiece.

If an external force over the allowable moment is applied, it may cause play in the guide or an increase in the sliding resistance.

6. Keep the flatness of the mounting surface within 0.1 mm/500 mm.

If a workpiece or base does not sit evenly on the body of the product, play in the guide or an increase in the sliding resistance may occur.

In the case of overhang mounting (including cantilever), use a support plate or support guide to avoid deflection of the actuator body.

7. When mounting the actuator, use all mounting holes.

If all mounting holes are not used, it influences the specifications, e.g., the amount of displacement of the table increases.

8. Do not allow a workpiece to collide with the table during the positioning operation or within the positioning range.

9. Do not apply external force to the dust seal band.

Particularly during the transportation

LEFS
LEFBLEJS
LEJB

LEL

LEM
LEMBLEY
LEYGLES
LESHLEPY
LEPS

LER

LEH

LEY-X5

11-LEFS

11-LEJS

25A-

LEC

JXC

LECS
LECS-T

LECY

Motorless

LAT3



LEJS Series Specific Product Precautions 2

Be sure to read this before handling the products. Refer to page 984 for safety instructions, pages 985 to 990 for electric actuator precautions, and pages 991 to 1000 for auto switch precautions.

Handling

⚠ Caution

10. When mounting the product, use screws of adequate length and tighten them with adequate torque.

Tightening the screws with a higher torque than recommended may result in a malfunction, while tightening with a lower torque can result in the displacement of the mounting position or, in extreme conditions, the actuator could become detached from its mounting position.

Body fixed

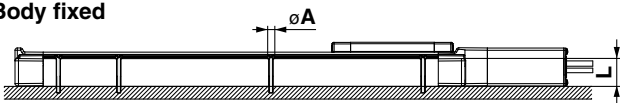

Model	Screw size	Max. tightening torque [N·m]	ϕA [mm]	L [mm]
LEJS40	M5	3.0	5.5	36.5
LEJS63	M6	5.2	6.8	49.5

Workpiece fixed

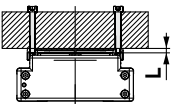

Model	Screw size	Max. tightening torque [N·m]	L (Max. screw-in depth) [mm]
LEJS40	M6 x 1	5.2	10
LEJS63	M8 x 1.25	12.5	12

To prevent the workpiece retaining screws from touching the body, use screws that are 0.5 mm or shorter than the maximum screw-in depth. If long screws are used, they may touch the body and cause a malfunction.

11. Do not operate by fixing the table and moving the actuator body.

12. When mounting the actuator using the body mounting reference plane, use a pin. Set the height of the pin to be 5 mm or more because of round chamfering. (Recommended height 6 mm)

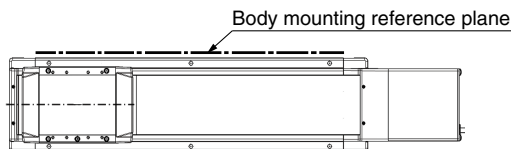

Maintenance

⚠ Warning

Maintenance frequency

Perform maintenance according to the table below.

Frequency	Appearance check	Internal check
Inspection before daily operation	○	—
Inspection every 6 months/1000 km/5 million cycles*1	○	○

*1 Select whichever comes first.

• Items for visual appearance check

1. Loose set screws, Abnormal amount of dirt, etc.
2. Check for visible damage, Check of cable joint
3. Vibration, Noise

• Items for internal check

1. Lubricant condition on moving parts
 - * For lubrication, use lithium grease No. 2.
2. Loose or mechanical play in fixed parts or fixing screws

Rod Type *LEY Series*

p. 901



Guide Rod Type *LEYG Series*

p. 917

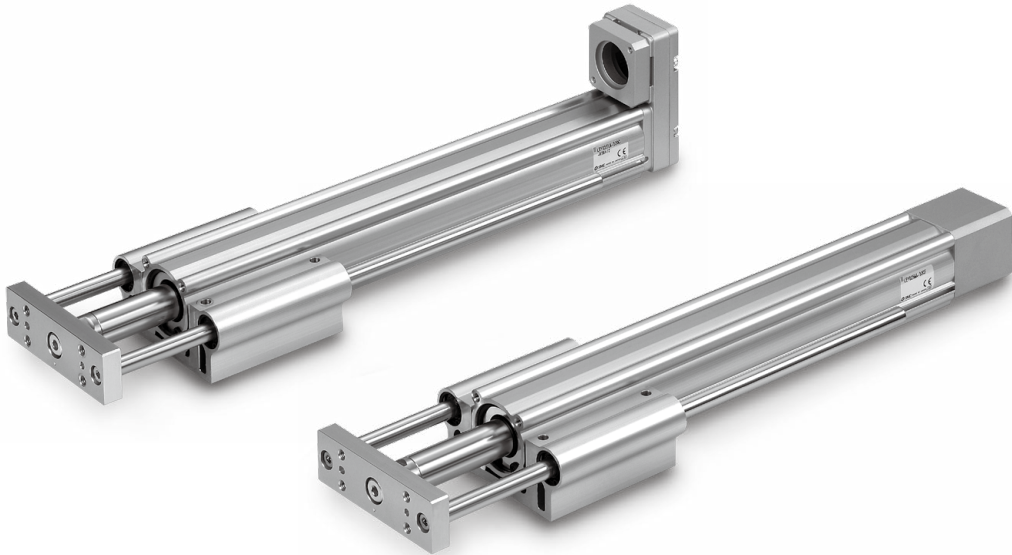

LEFS
LEFB

LEJS
LEJB

LEL

LEM

LEY
LEYG

LES
LESH

LEPY
LEPS

LER

LEH

LEY-X5

11-LEFS

11-LEJS

25A-

LEC

JXC

LECS
LECS-T

LECY

Motorless

LAT3



Selection Procedure

Positioning Control Selection Procedure



Selection Example

The model selection method shown below corresponds to SMC's standard motor. For use in combination with a motor from a different manufacturer, check the available product information of the motor to be used.

Operating conditions

- Work load: 16 [kg]
- Speed: 300 [mm/s]
- Acceleration/Deceleration: 5000 [mm/s²]
- Stroke: 300 [mm]
- Workpiece mounting condition: Vertical upward downward transfer

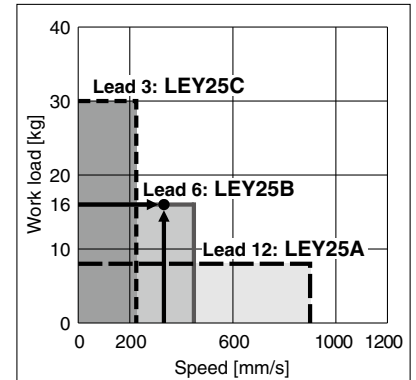

<Speed-Vertical Work Load Graph> (LEY25)

Step 1 Check the work load–speed. <Speed-Vertical Work Load Graph>

Select a model based on the workpiece mass and speed which are within the range of the actuator body specifications while referencing the speed–vertical work load graph on page 903.

Selection example) The **LEY25B** can be temporarily selected as a possible candidate based on the graph shown on the right side.

* It is necessary to mount a guide outside the actuator when used for horizontal transfer. When selecting the target model, refer to horizontal work load in the specifications on pages 908 and 909 and, the precautions.

* Refer to the selection method of motor manufacturers for regeneration resistance.

Step 2 Check the cycle time.

Calculate the cycle time using the following calculation method.

Cycle time:

T can be found from the following equation.

$$T = T1 + T2 + T3 + T4 \text{ [s]}$$

- T1: Acceleration time and T3: Deceleration time can be found by the following equation.

$$T1 = V/a1 \text{ [s]} \quad T3 = V/a2 \text{ [s]}$$

- T2: Constant speed time can be found from the following equation.

$$T2 = \frac{L - 0.5 \cdot V \cdot (T1 + T3)}{V} \text{ [s]}$$

- T4: Settling time varies depending on the motor type and load. The value below is recommended.

$$T4 = 0.05 \text{ [s]}$$

* The conditions for the settling time vary depending on the motor or driver to be used.

Calculation example)

T1 to T4 can be calculated as follows.

$$T1 = V/a1 = 300/5000 = 0.06 \text{ [s]}, \quad T3 = V/a2 = 300/5000 = 0.06 \text{ [s]}$$

$$T2 = \frac{L - 0.5 \cdot V \cdot (T1 + T3)}{V} = \frac{300 - 0.5 \cdot 300 \cdot (0.06 + 0.06)}{300} = 0.94 \text{ [s]}$$

$$T4 = 0.05 \text{ [s]}$$

The cycle time can be found as follows.

$$T = T1 + T2 + T3 + T4 = 0.06 + 0.94 + 0.06 + 0.05 = 1.11 \text{ [s]}$$

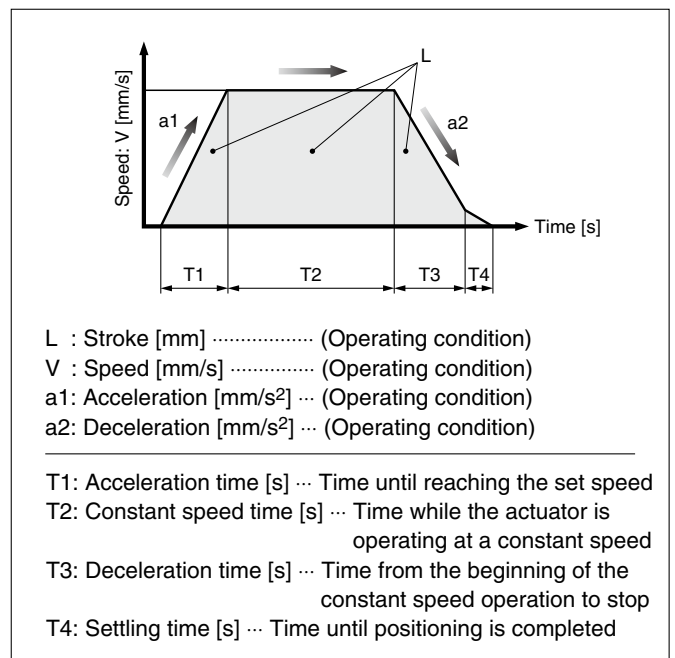

Based on the above calculation result, the **LEY25B-300** should be selected.

Selection Procedure

Pushing Control Selection Procedure

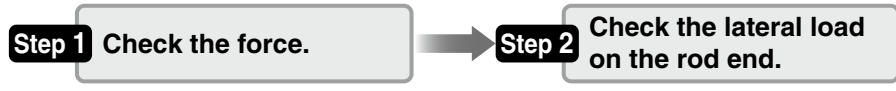

Selection Example

The model selection method shown below corresponds to SMC's standard motor. For use in combination with a motor from a different manufacturer, check the available product information of the motor to be used.

Operating conditions

- Mounting condition: Horizontal (pushing)
- Speed: 100 [mm/s]
- Jig weight: 0.5 [kg]
- Stroke: 300 [mm]
- Force: 255 [N]

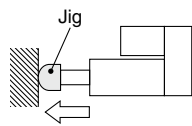

Step 1 Check the force. <Force Conversion Graph>

Select a model based on the ratio to rated torque and force while referencing the force conversion graph.

Selection example)

Based on the graph shown on the right side,

- Ratio to rated torque: 90 [%]
- Force: 255 [N]

The LEY25B can be temporarily selected as a possible candidate.

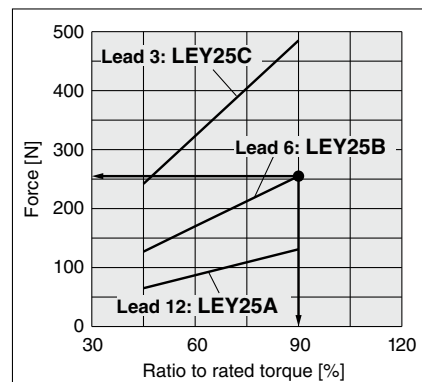

Step 2 Check the lateral load on the rod end. <Graph of Allowable Lateral Load on the Rod End>

Confirm the allowable lateral load on the rod end of the actuator: LEY25B, which has been selected temporarily while referencing the graph of allowable lateral load on the rod end.

Selection example)

Based on the graph shown on the right side,

- Jig weight: 0.5 [kg] ≈ 5 [N]
- Product stroke: 300 [mm]

The lateral load on the rod end is within the allowable range.

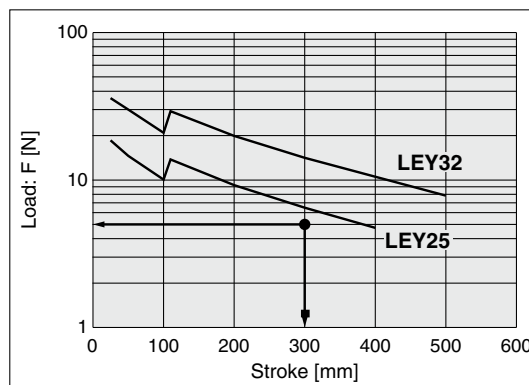

Based on the above calculation result, the LEY25B-300 should be selected.

- LEFS
- LEFB
- LEJS
- LEJB
- LEL
- LEM
- LEY
- LEYG
- LES
- LESH
- LEPY
- LEPS
- LER
- LEH
- LEH
- LEY-X5
- 11-LEFS
- 11-LEJS
- 25A-
- LEC
- JXC
- LECS
- LECS-T
- LECY
- Motorless
- LAT3

LEY Series

Motorless Type

Size 25, 32, 63

* The values shown below are allowable values of the actuator body. Do not use the actuator so that it exceeds these specification ranges.

* The allowable speed is restricted depending on the stroke. Select it by referring to the "Allowable Stroke Speed."

Speed-Vertical Work Load Graph

LEY25□ (Motor mounting position: Top/Parallel, In-line)

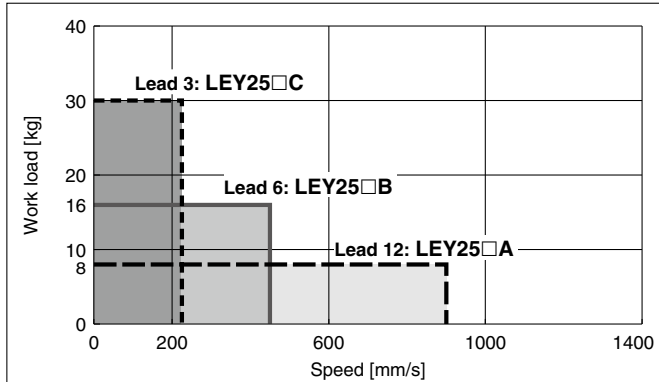

LEY32□ (Motor mounting position: Top/Parallel)

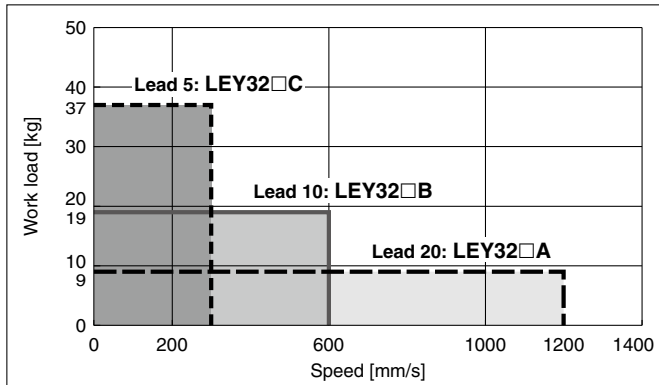

LEY32D (Motor mounting position: In-line)

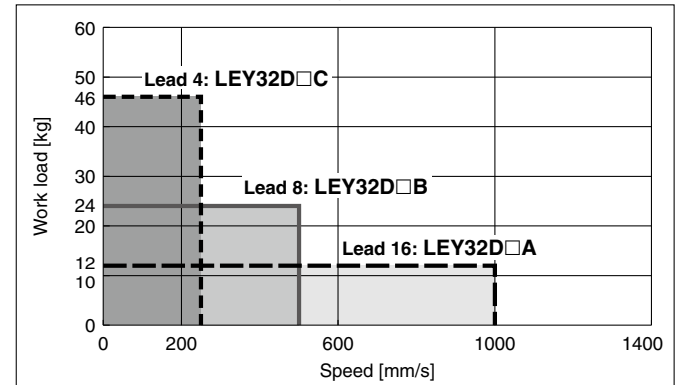

LEY63□ (Motor mounting position: Top/Parallel, In-line)

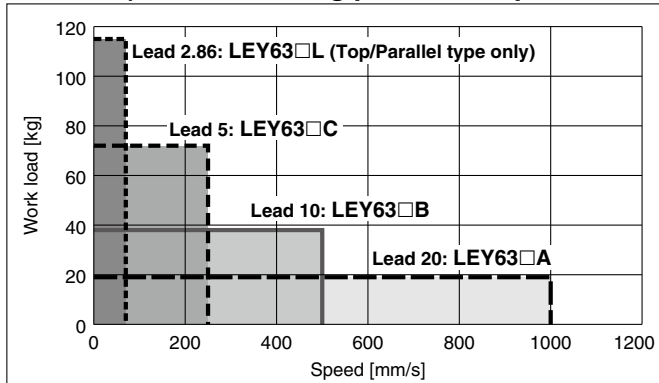

* The values shown below are allowable values of the actuator body. Do not use the actuator so that it exceeds these specification ranges.

* The allowable speed is restricted depending on the stroke. Select it by referring to the "Allowable Stroke Speed."

Speed–Horizontal Work Load Graph

LEY25□ (Motor mounting position: Top/Parallel, In-line)

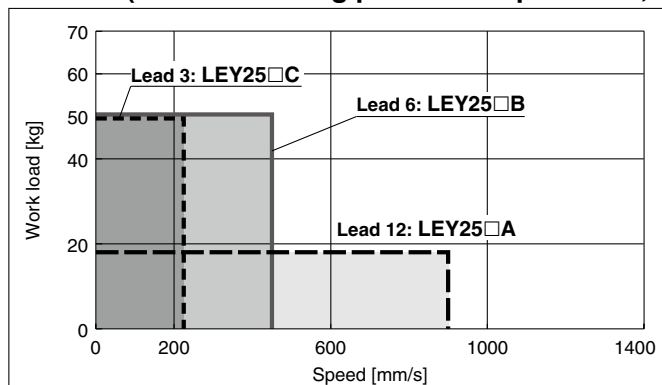

LEY32□ (Motor mounting position: Top/Parallel)

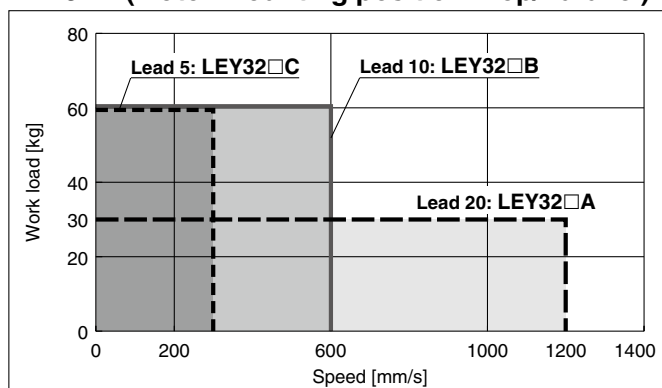

LEY32D (Motor mounting position: In-line)

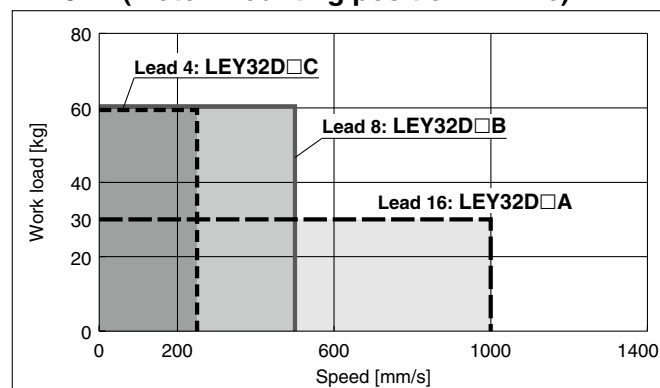

LEY63□ (Motor mounting position: Top/Parallel, In-line)

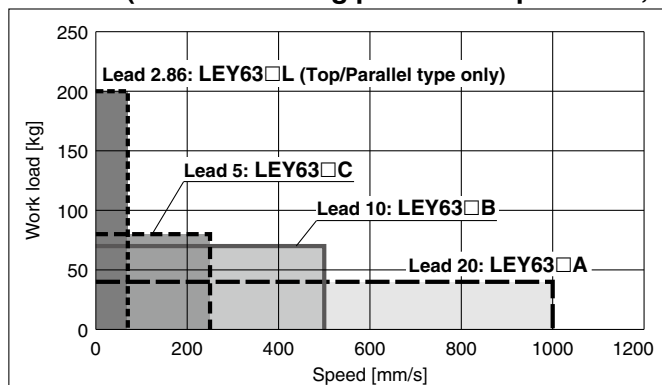

Allowable Stroke Speed

Model	Motor	Lead		Stroke [mm]								
		Symbol	[mm]	Up to 100	Up to 200	Up to 300	Up to 400	Up to 500	Up to 600	Up to 700	Up to 800	
LEY25□ (Motor mounting position: Top/Parallel, In-line)	100 W equivalent	A	12		900		600	—	—	—	—	
		B	6		450		300	—	—	—	—	
		C	3		225		150	—	—	—	—	
		(Motor rotation speed)			(4500 rpm)		(3000 rpm)		—	—	—	—
LEY32□ (Motor mounting position: Top/Parallel)	200 W equivalent	A	20		1200		800	—	—	—	—	
		B	10		600		400	—	—	—	—	
		C	5		300		200	—	—	—	—	
		(Motor rotation speed)			(3600 rpm)		(2400 rpm)		—	—	—	—
LEY32D (Motor mounting position: In-line)	200 W equivalent	A	16		1000		640	—	—	—	—	
		B	8		500		320	—	—	—	—	
		C	4		250		160	—	—	—	—	
		(Motor rotation speed)			(3750 rpm)		(2400 rpm)		—	—	—	—
LEY63□	400 W equivalent	A	20		1000		800	600	500			
		B	10		500		400	300	250			
		C	5		250		200	150	125			
		(Motor rotation speed)			(3000 rpm)		(2400 rpm)		(1800 rpm)	(1500 rpm)		
		L	2.86*1				70					
(Motor rotation speed)					(1470 rpm)							

*1 Equivalent lead which includes the screw lead 5 and the pulley ratio 4:7

- LEFS
- LEFB
- LEJS
- LEJB
- LEL
- LEM
- LEY
- LEYG
- LES
- LESH
- LEPY
- LEPS
- LER
- LEH
- LEH-X5
- 11-LEFS
- 11-LEJS
- 11-LEJS
- 25A-
- LEC
- JXC
- LECS
- LECS-T
- LECY
- Motorless
- LAT3

LEY Series

Motorless Type

Size 25, 32, 63

Force Conversion Graph (Guide)

* These graphs show an example of when the standard motor is mounted. Calculate the force based on used motor and driver.

LEY25□ (Motor mounting position: Top/Parallel, In-line)

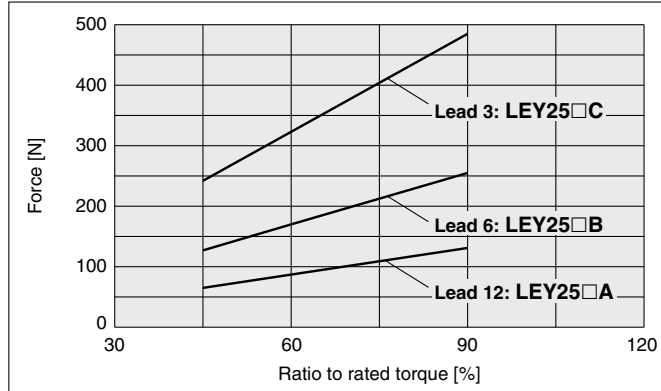

LEY32□ (Motor mounting position: Top/Parallel)

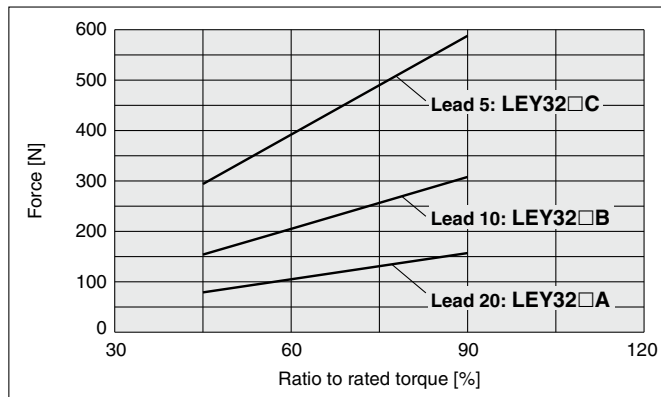

LEY32D□ (Motor mounting position: In-line)

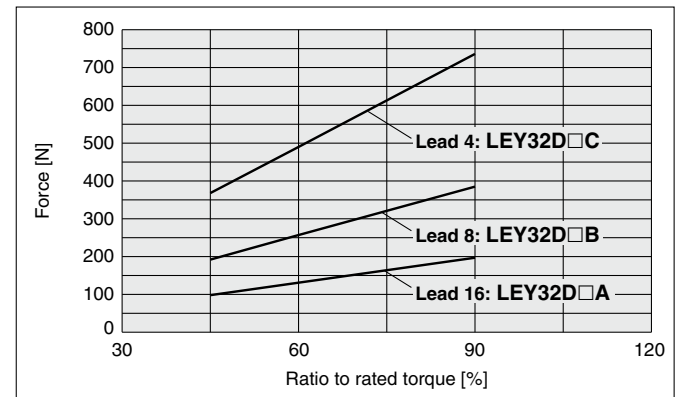

* When using the force control or speed control, set the maximum value to be no more than 90% of the rated torque.

LEY63□ (Motor mounting position: Top/Parallel, In-line)

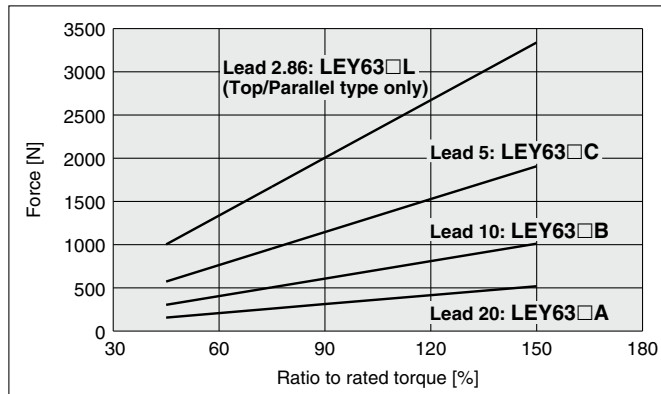

Graph of Allowable Lateral Load on the Rod End (Guide)

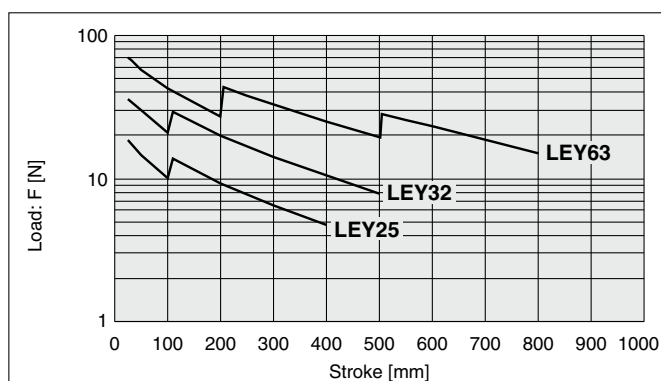

$$[\text{Stroke}] = [\text{Product stroke}] + [\text{Distance from the rod end to the center of gravity of the workpiece}]$$

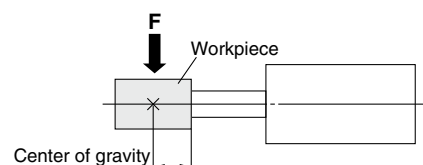

- LAT3
- Motorless
- LECY
- LECS JXC LEC
- LECS T
- 25A-
- 11-LEJS
- 11-LEFS
- LEY-X5
- LEH
- LER
- LEPY
LEPS
- LES
LESH
- LEY
LEYG
- LEM
- LEL
- LEJS
LEJB
- LEFS
LEFB

Electric Actuator Rod Type

LEY Series LEY25, 32, 63



RoHS

How to Order

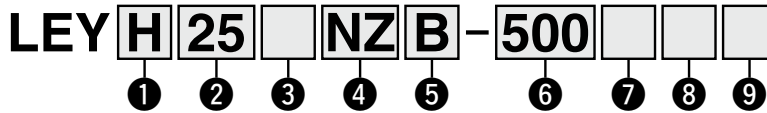

1 Accuracy

Nil	Basic type
H	High-precision type

2 Size

25
32
63

4 Motor type

Symbol	Type	Symbol	Type
NZ	Mounting type Z	NU	Mounting type U
NY	Mounting type Y	NT	Mounting type T
NX	Mounting type X	NM1	Mounting type M1
NW	Mounting type W	NM2	Mounting type M2
NV	Mounting type V	NM3	Mounting type M3

5 Lead [mm]

Symbol	LEY25	LEY32	LEY63
A	12	16 (20)	20
B	6	8 (10)	10
C	3	4 (5)	5
L	—	—	2.86*1

6 Stroke [mm]

30	30
to	to
800	800

* Refer to the applicable stroke table.

3 Motor mounting position

Nil	Top mounting
R	Right side parallel
L	Left side parallel
D	In-line

*1 Only available for top mounting and right/left side parallel types (Equivalent leads which include the pulley ratio [4:7])
 * The values shown in () are the leads for the top mounting, right/left side parallel types. Except motor type NM1 (Equivalent leads which include the pulley ratio [1.25:1])

8 Rod end thread

Nil	Rod end female thread
M	Rod end male thread (1 rod end nut is included.)

7 Dust-tight/Water-jet-proof <Only available for LEY63>

Symbol	LEY25/32	LEY63
Nil	IP4x equivalent	IP5x equivalent (Dust protected)
P	—	IP65 equivalent (Dust-tight/Water-jet-proof)/With vent hole tap

* When using the dust-tight/water-jet-proof (IP65 equivalent), correctly mount the fitting and tubing to the vent hole tap, and then place the end of the tubing in an area not exposed to dust or water.
 * The fitting and tubing should be provided separately by the customer. Select [Applicable tubing O.D.: φ4 or more, Connection thread: Rc1/8].
 * Cannot be used in environments exposed to cutting oil, etc. Take appropriate protective measures.
 * For details on enclosure, refer to the "Enclosure" on pages 937 and 938.

Applicable Stroke Table

●: Standard

Model	Stroke [mm]	30	50	100	150	200	250	300	350	400	450	500	600	700	800
LEY25		●	●	●	●	●	●	●	●	●	—	—	—	—	—
LEY32		●	●	●	●	●	●	●	●	●	●	●	—	—	—
LEY63		—	●	●	●	●	●	●	●	●	●	●	●	●	●

* Please consult with SMC for non-standard strokes as they are produced as special orders.

Compatible Motors

Applicable motor model			Size/Motor type																					
Manufacturer	Series	Type	25								32				63									
			NZ	NY	NX	NM1	NM2	NM3	NZ	NY	NX	NW	NU	NT	NM1	NM2	NZ	NY	NX	NW	NV	NU	NT	
Mitsubishi Electric Corporation	MELSERVO-JN	HF-KN	●	—	—	—	—	—	—	—	—	—	—	—	—	—	—	—	—	—	—	—	—	—
	MELSERVO-J4	HG-KR	●	—	—	—	—	—	—	—	—	—	—	—	—	—	—	—	—	—	—	—	—	—
	MELSERVO-J5	HK-KT	●	—	—	—	—	—	—	—	—	—	—	—	—	—	—	—	—	—	—	—	—	—
YASKAWA Electric Corporation	Σ-V	SGMJV	●	—	—	—	—	—	—	—	—	—	—	—	—	—	—	—	—	—	—	—	—	—
	Σ-7	SGM7J/SGM7A	●	—	—	—	—	—	—	—	—	—	—	—	—	—	—	—	—	—	—	—	—	—
SANYO DENKI CO., LTD.	SANMOTION R	R2	●	—	—	—	—	—	—	—	—	—	—	—	—	—	—	—	—	—	—	—	—	—
OMRON Corporation	Symac G5	R88M-K	●	—	—	—	—	—	—	—	—	—	—	—	—	—	—	—	—	—	—	—	—	—
	1 S	R88M-1	●	—	—	—	—	—	—	—	—	—	—	—	—	—	—	—	—	—	—	—	—	—
Panasonic Corporation	MINAS A5	MSM□/MHMD	—	●	—	—	—	—	—	—	—	—	—	—	—	—	—	—	—	—	—	—	—	—
		MSMF	—	●	—	—	—	—	—	—	—	—	—	—	—	—	—	—	—	—	—	—	—	—
		MHMF	●	—	—	—	—	—	—	—	—	—	—	—	—	—	—	—	—	—	—	—	—	—
FANUC CORPORATION	βis (-B)	β	●	—	—	—	—	—	—	—	—	—	—	—	—	—	—	—	—	—	—	—	—	
NIDEC SANKYO CORPORATION	S-FLAG	MA/MH/MM	●	—	—	—	—	—	—	—	—	—	—	—	—	—	—	—	—	—	—	—	—	—
KEYENCE CORPORATION	SV	SV-M/SV-B	●	—	—	—	—	—	—	—	—	—	—	—	—	—	—	—	—	—	—	—	—	—
	SV2	SV2-M/SV2-B	●	—	—	—	—	—	—	—	—	—	—	—	—	—	—	—	—	—	—	—	—	—
FUJI ELECTRIC CO., LTD.	ALPHA5	GYS/GYB	●	—	—	—	—	—	—	—	—	—	—	—	—	—	—	—	—	—	—	—	—	—
	ALPHA7	GYS/GYB	●	—	—	—	—	—	—	—	—	—	—	—	—	—	—	—	—	—	—	—	—	—
	FALDIC α	GYS	●	—	—	—	—	—	—	—	—	—	—	—	—	—	—	—	—	—	—	—	—	—
MinebeaMitsumi Inc.	SZ	A17PM/A23KM	—	—	—	—	●*1	—	—	—	—	—	—	—	—	—	—	—	—	—	—	—	—	
Shinano Kenshi Co., Ltd.	CSB-BZ	CSB-BZ	—	—	—	—	—	●*1	—	—	—	—	—	—	—	—	—	—	—	—	—	—	—	
ORIENTAL MOTOR Co., Ltd.	AR/AZ	AR/AZ (46 only)	—	—	—	—	—	—	—	—	—	—	—	—	—	—	—	—	—	—	—	—	—	—
	AR/AZ	AR/AZ	—	—	—	—	—	—	—	—	—	—	—	—	—	—	—	—	—	—	—	—	—	—
FASTECH Co., Ltd.	Ezi-SERVO	EzM	—	—	—	—	—	—	—	—	—	—	—	—	—	—	—	—	—	—	—	—	—	
Rockwell Automation, Inc. (Allen-Bradley)	MP-/VP-	MP/VP	—	—	—	—	—	—	—	—	—	—	—	—	—	—	—	—	—	—	—	—	—	
	TL	TLY-A	●	—	—	—	—	—	—	—	—	—	—	—	—	—	—	—	—	—	—	—	—	
Beckhoff Automation GmbH	AM	AM30	●	—	—	—	—	—	—	—	—	—	—	—	—	—	—	—	—	—	—	—	—	
	AM	AM31	●	—	—	—	—	—	—	—	—	—	—	—	—	—	—	—	—	—	—	—	—	
	AM	AM80/AM81	●	—	—	—	—	—	—	—	—	—	—	—	—	—	—	—	—	—	—	—	—	
Siemens AG	1FK7	1FK7	—	—	—	—	—	—	—	—	—	—	—	—	—	—	—	—	—	—	—	—	—	
Delta Electronics, Inc.	ASDA-A2	ECMA	●	—	—	—	—	—	—	—	—	—	—	—	—	—	—	—	—	—	—	—	—	
ANCA Motion	AMD2000	Alpha	●	—	—	—	—	—	—	—	—	—	—	—	—	—	—	—	—	—	—	—	—	

*1 Motor mounting position: In-line only *2 Motor mounting position: Top/parallel only

For auto switches, refer to pages 933 to 936.

Specifications

- Values in this specifications table are the allowable values of the actuator body with the standard motor mounted.
- Do not use the actuator so that it exceeds these values.

Model			LEY25 (Top/Parallel) LEY25D (In-line)			LEY32 (Top/Parallel)			LEY32D (In-line)		
Work load [kg]	Horizontal*1		18	50	50	30	60	60	30	60	60
	Vertical		8	16	30	9	19	37	12	24	46
Force [N]*2 (Set value: Rated torque 45 to 90%)			65 to 131	127 to 255	242 to 485	79 to 157	154 to 308	294 to 588	98 to 197	192 to 385	368 to 736
Max.*3 speed [mm/s]	Stroke range	Up to 300	900	450	225	1200	600	300	1000	500	250
		305 to 400	600	300	150						
		405 to 500	—	—	—	800	400	200	640	320	160
Pushing speed [mm/s]*4			35 or less			30 or less					
Max. acceleration/deceleration [mm/s ²]						5000					
Positioning repeatability [mm]	Basic type					±0.02					
	High-precision type					±0.01					
Lost motion*5 [mm]	Basic type					0.1 or less					
	High-precision type					0.05 or less					
Ball screw specifications	Thread size [mm]		ø10			ø12					
	Lead [mm] (including pulley ratio)		12	6	3	16 (20)	8 (10)	4 (5)	16	8	4
	Shaft length [mm]		Stroke + 93.5			Stroke + 104.5					
Impact/Vibration resistance [m/s ²]*6						50/20					
Actuation type			Ball screw + Belt (Top/Parallel) Ball screw (In-line)			Ball screw + Belt [Pulley ratio 1.25:1]			Ball screw		
Guide type						Sliding bushing (Piston rod)					
Operating temperature range [°C]						5 to 40					
Operating humidity range [%RH]						90 or less (No condensation)					
Actuation unit weight [kg] (* [ST]: Stroke)			0.15 + (0.69 × 10 ⁻³) × [ST]: 100 st or less 0.16 + (0.69 × 10 ⁻³) × [ST]: Over 100 st			0.24 + (1.40 × 10 ⁻³) × [ST]: 100 st or less 0.28 + (1.40 × 10 ⁻³) × [ST]: Over 100 st					
Other inertia [kg·cm ²]			0.012 (LEY25), 0.015 (LEY25D)			0.035 (LEY32), 0.061 (LEY32D)					
Friction coefficient						0.05					
Mechanical efficiency						0.8					
Motor shape			<input type="checkbox"/> 40			<input type="checkbox"/> 60					
Motor type						AC servo motor					
Rated output capacity [W]			100			200					
Rated torque [N·m]			0.32			0.64					

- *1 This is the maximum value of the horizontal work load. An external guide is necessary to support the load (Friction coefficient of guide: 0.1 or less). The actual work load changes according to the condition of the external guide. Confirm the load using the actual device.
- *2 The force setting range for the force control (Speed control mode, Torque control mode)
The force changes according to the set value. Set it with reference to the "Force Conversion Graph (Guide)" on page 905.
- *3 The allowable speed changes according to the stroke.
- *4 The allowable collision speed for collision with the workpiece
- *5 A reference value for correcting an error in reciprocal operation

- *6 Impact resistance: No malfunction occurred when the actuator was tested with a drop tester in both an axial direction and a perpendicular direction to the lead screw. (The test was performed with the actuator in the initial state.)
Vibration resistance: No malfunction occurred in a test ranging between 45 to 2000 Hz. The test was performed in both an axial direction and a perpendicular direction to the lead screw. (The test was performed with the actuator in the initial state.)
- *7 Each value is only to be used as a guide to select a motor of the appropriate capacity.
- *8 For other specifications, refer to the specifications of the motor that is to be installed.

Weight

Product Weight

Series	LEY25 (Motor mounting position: Top/Parallel)										LEY32 (Motor mounting position: Top/Parallel)									
Stroke [mm]	30	50	100	150	200	250	300	350	400	30	50	100	150	200	250	300	350	400	450	500
Product weight [kg]	0.8	0.9	1.1	1.3	1.5	1.7	1.8	2.0	2.2	1.4	1.5	1.8	2.3	2.6	2.9	3.1	3.4	3.7	4.0	4.3

Series	LEY25D (Motor mounting position: In-line)										LEY32D (Motor mounting position: In-line)									
Stroke [mm]	30	50	100	150	200	250	300	350	400	30	50	100	150	200	250	300	350	400	450	500
Product weight [kg]	0.8	0.9	1.1	1.3	1.5	1.7	1.9	2.0	2.2	1.4	1.6	1.8	2.3	2.6	2.9	3.2	3.4	3.7	4.0	4.3

Additional Weight

Size		25	32
Rod end male thread	Male thread	0.03	0.03
	Nut	0.02	0.02
Foot bracket (2 sets including mounting bolt)		0.08	0.14
Rod flange (including mounting bolt)		0.17	0.20
Head flange (including mounting bolt)			
Double clevis (including pin, retaining ring, and mounting bolt)		0.16	0.22

- LEFS
- LEFB
- LEJS
- LEJB
- LEL
- LEM
- LEY
- LEYG
- LES
- LESH
- LEPY
- LEPS
- LER
- LEH
- LEH
- LEY-X5
- 11-LEFS
- 11-LEJS
- 11-LEIS
- 25A-
- LEC
- JXC
- LECS
- LECS-T
- LECY
- Motorless
- LAT3

LEY Series

Motorless Type

Size **63**

Specifications

- Values in this specifications table are the allowable values of the actuator body with the standard motor mounted.
- Do not use the actuator so that it exceeds these values.

Model		LEY63D (In-line)					LEY63 (Top/Parallel)			
Actuator specifications	Work load [kg]	Horizontal*1	40	70	80	40	70	80	200	
		Vertical	19	38	72	19	38	72	115	
	Force [N]*2 (Set value: Rated torque 45 to 150%)		156 to 521	304 to 1012	573 to 1910	156 to 521	304 to 1012	573 to 1910	1003 to 3343	
	Max.*3 speed [mm/s]	Stroke range	Up to 500	1000	500	250	1000	500	250	70
			505 to 600	800	400	200	800	400	200	
			605 to 700	600	300	150	600	300	150	
			705 to 800	500	250	125	500	250	125	
	Pushing speed [mm/s]*4		30 or less							
	Max. acceleration/deceleration [mm/s ²]		5000						3000	
	Positioning repeatability [mm]	Basic type	±0.02							
High-precision type		±0.01								
Lost motion*5 [mm]	Basic type	0.1 or less								
	High-precision type	0.05 or less								
Ball screw specifications	Thread size [mm]	ø20								
	Lead [mm]	20	10	5	20	10	5	5 (2.86)		
	Shaft length [mm]	Stroke + 147								
Impact/Vibration resistance [m/s ²]*6		50/20								
Actuation type		Ball screw			Ball screw + Belt [Pulley ratio 1:1]			Ball screw + Belt [Pulley ratio 4:7]		
Guide type		Sliding bushing (Piston rod)								
Operating temperature range [°C]		5 to 40								
Operating humidity range [%RH]		90 or less (No condensation)								
* Other specifications	Actuation unit weight [kg] (* [ST]: Stroke)		0.84 + (2.77 × 10 ⁻³) × [ST]: 200 st or less 0.94 + (2.77 × 10 ⁻³) × [ST]: Over 200 st, 500 st or less 1.03 + (2.77 × 10 ⁻³) × [ST]: Over 500 st							
	Other inertia [kg·cm ²]		0.056 (LEY63D)			0.110		0.053		
	Friction coefficient		0.05							
	Mechanical efficiency		0.8							
* Reference motor spec.	Motor shape		□60							
	Motor type		AC servo motor							
	Rated output capacity [W]		400							
	Rated torque [N·m]		1.27							

- *1 This is the maximum value of the horizontal work load. An external guide is necessary to support the load (Friction coefficient of guide: 0.1 or less). The actual work load changes according to the condition of the external guide. Confirm the load using the actual device.
- *2 The force setting range for the force control (Speed control mode, Torque control mode)
The force changes according to the set value. Set it with reference to the "Force Conversion Graph (Guide)" on page 905.
- *3 The allowable speed changes according to the stroke.
- *4 The allowable collision speed for collision with the workpiece
- *5 A reference value for correcting an error in reciprocal operation

- *6 Impact resistance: No malfunction occurred when the actuator was tested with a drop tester in both an axial direction and a perpendicular direction to the lead screw. (The test was performed with the actuator in the initial state.)
Vibration resistance: No malfunction occurred in a test ranging between 45 to 2000 Hz. The test was performed in both an axial direction and a perpendicular direction to the lead screw. (The test was performed with the actuator in the initial state.)
- *7 Each value is only to be used as a guide to select a motor of the appropriate capacity.
- *8 For other specifications, refer to the specifications of the motor that is to be installed.

Weight

Product Weight

Model	LEY63D (Motor mounting position: In-line)												
Stroke [mm]	50	100	150	200	250	300	350	400	450	500	600	700	800
Product weight [kg]	3.7	4.2	4.8	5.3	6.5	7.0	7.6	8.2	8.8	9.3	11.0	12.1	13.3

Model	LEY63 (Motor mounting position: Top/Parallel)												
Stroke [mm]	50	100	150	200	250	300	350	400	450	500	600	700	800
Product weight [kg]	3.5	4.0	4.7	5.2	6.4	6.9	7.5	8.0	8.6	9.1	10.8	12.0	13.1

Additional Weight

Size		63
Rod end male thread	Male thread	0.12
	Nut	0.04
Rod flange (including mounting bolt)		0.51
Foot bracket (2 sets including mounting bolt)		0.26
Double clevis (including pin, retaining ring, and mounting bolt)		0.58

Refer to the "Motor Mounting" on pages 925 and 926 for details about motor mounting and included parts.

Dimensions: Motor Top/Parallel

LEY25, 32, 63

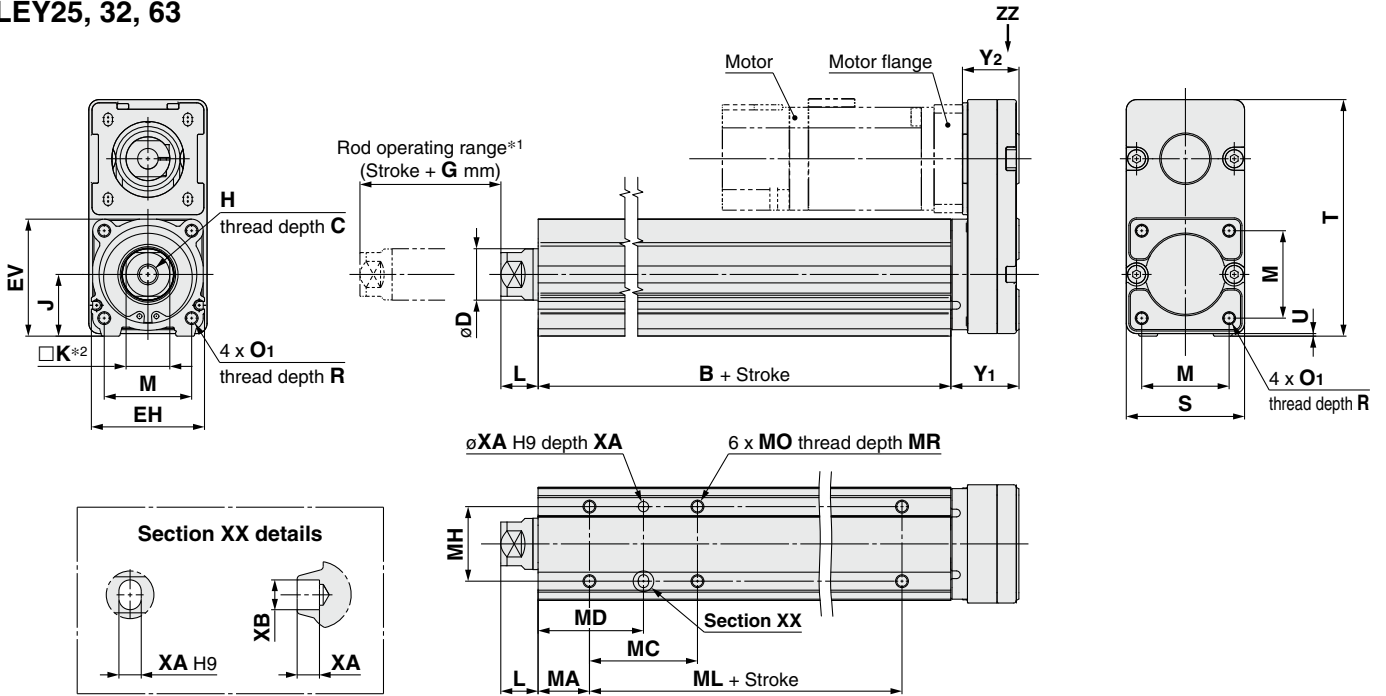

- *1 Do not allow collisions at either end of the rod operating range at a speed exceeding "pushing speed." Additionally, when running the positioning operation, do not set within 2 mm of both ends for size 25, 32, and do not set within 4 mm of both ends for size 63.
- *2 The direction of rod end width across flats (□K) differs depending on the products.

**IP65 equivalent (Dust-tight/Water-jet-proof):
LEY63□□□-□P (View ZZ)**

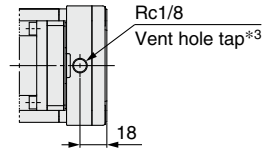

- *3 When using the dust-tight/water-jet-proof (IP65 equivalent), correctly mount the fitting and tubing to the vent hole tap, and then place the end of the tubing in an area not exposed to dust or water. The fitting and tubing should be provided separately by the customer. Select [Applicable tubing O.D.: ø4 or more, Connection thread: Rc1/8].

Dimensions

Size	Stroke range [mm]	B	C	D	EH	EV	H	J	K	L	M	O ₁	R	S	T	U	Y ₁	Y ₂	G
25	15 to 100	89.5	13	20	44	45.5	M8 x 1.25	24	17	12.5	34	M5 x 0.8	8	46	92	1	26.5	22	4
	105 to 400	114.5																	
32	20 to 100	96	13	25	51	56.5	M8 x 1.25	31	22	16.5	40	M6 x 1.0	10	60	118	1	34	27	4
	105 to 500	126																	
63	Up to 200	123																	
	205 to 500	158	21	40	76	82	M16 x 2	44	36	33.4	60	M8 x 1.25	16	80	146	4	32.2	29	8
	505 to 800	193																	

* The L measurement is when the unit is at the retracted stroke end position.

Size	Stroke range [mm]	MA	MC	MD	MH	ML	MO	MR	XA	XB
25	15 to 39		24	32						
	40 to 100		42	41		50	M5 x 0.8	6.5	4	5
	101 to 124	20	59	49.5	29	75				
	125 to 200		76	58						
201 to 400		22	36							
32	20 to 39		22	36		50	M6 x 1	8.5	5	6
	40 to 100	25	36	43	30	80				
	101 to 124		53	51.5						
	125 to 200		70	60						
63	201 to 500		70	60			M8 x 1.25	10	6	7
	50 to 70		24	50		65				
	75 to 120		45	60.5						
	125 to 200	38	58	67	44	100				
	205 to 500		86	81		135				

- LEFS
- LEFB
- LEJS
- LEJB
- LEL
- LEM
- LEY
- LEYG
- LES
- LESH
- LEPY
- LEPS
- LER
- LEH
- LEH
- LEY-X5
- 11-LEFS
- 11-LEJS
- 25A-
- LEC
- JXC
- LECS
- LECS-T
- LECY
- Motorless
- LAT3

LEY Series

Motorless Type

Size 25, 32, 63

Refer to the "Motor Mounting" on pages 925 and 926 for details about motor mounting and included parts.

Dimensions: Motor Top/Parallel

Motor flange dimensions

LEY25: NM1, NM2, NM3

LEY32: NM1, NM2

LEY25: NZ, NY, NX

LEY32: NZ, NY, NW, NU, NT

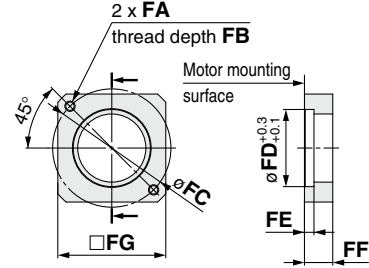
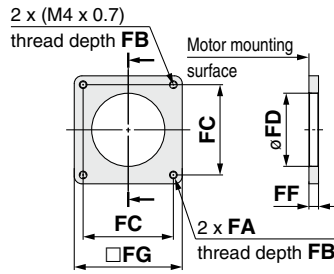
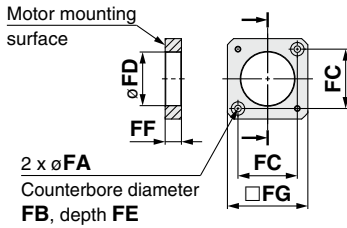

Dimensions

[mm]

Size	Motor type	FA	FB	FC	FD	FE	FF	FG
25	NZ	M4 x 0.7	7.5	46	30	3.7	11	42
	NY	M3 x 0.5	5.5	45	30	5	11	38
	NX	M4 x 0.7	7	46	30	3.7	8	42
	NM1, NM2	ø3.4	7	31	28	3.5	8.5	42
	NM3	ø3.4	7	31	28	3.5	5.5	42
32	NZ, NW, NU	M5 x 0.8	8.5	70	50	4.6	13	60
	NY	M4 x 0.7	7	70	50	4.6	13	60
	NT	M5 x 0.8	8.5	70	50	4.6	17	60
	NM1	M4 x 0.7	(5)	47.1	38.2	—	5	56.4
	NM2	M4 x 0.7	8	50	38.2	—	11.5	60
63	NZ, NW	M5 x 0.8	8.5	70	50	4.6	11	60
	NY	M4 x 0.7	8	70	50	4.6	11	60
	NT	M5 x 0.8	8.5	70	50	4.6	14.5	60

LEY63: NZ, NY, NW, NT

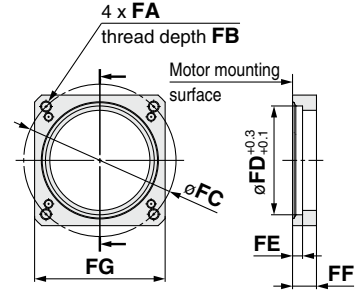

Motor left side parallel type: LEY32L
25
63

Motor right side parallel type: LEY32R
25
63

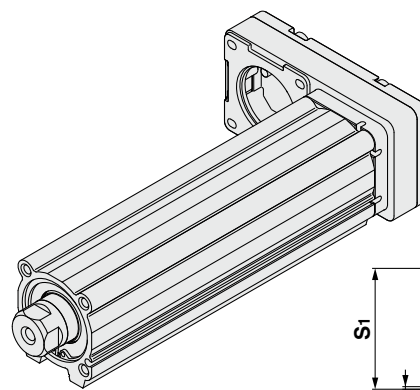
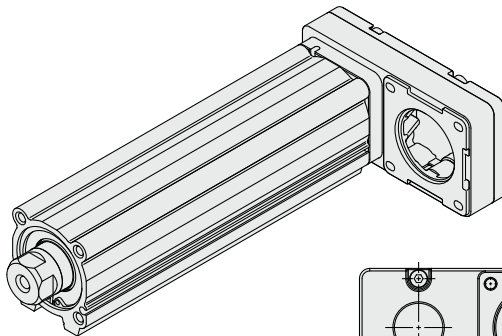

Size	S1	T2	U
25	47	91	1
32	61	117	1
63	84	142	4

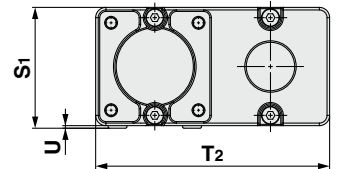
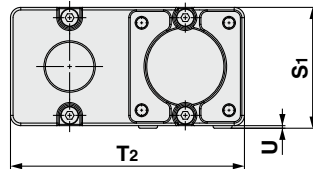

* When the motor is mounted on the left or right side in parallel, the groove for auto switch on the side to which the motor is mounted is hidden.

Refer to the "Motor Mounting" on page 927 for details about motor mounting and included parts.

Dimensions: In-line Motor

LEY25, 32

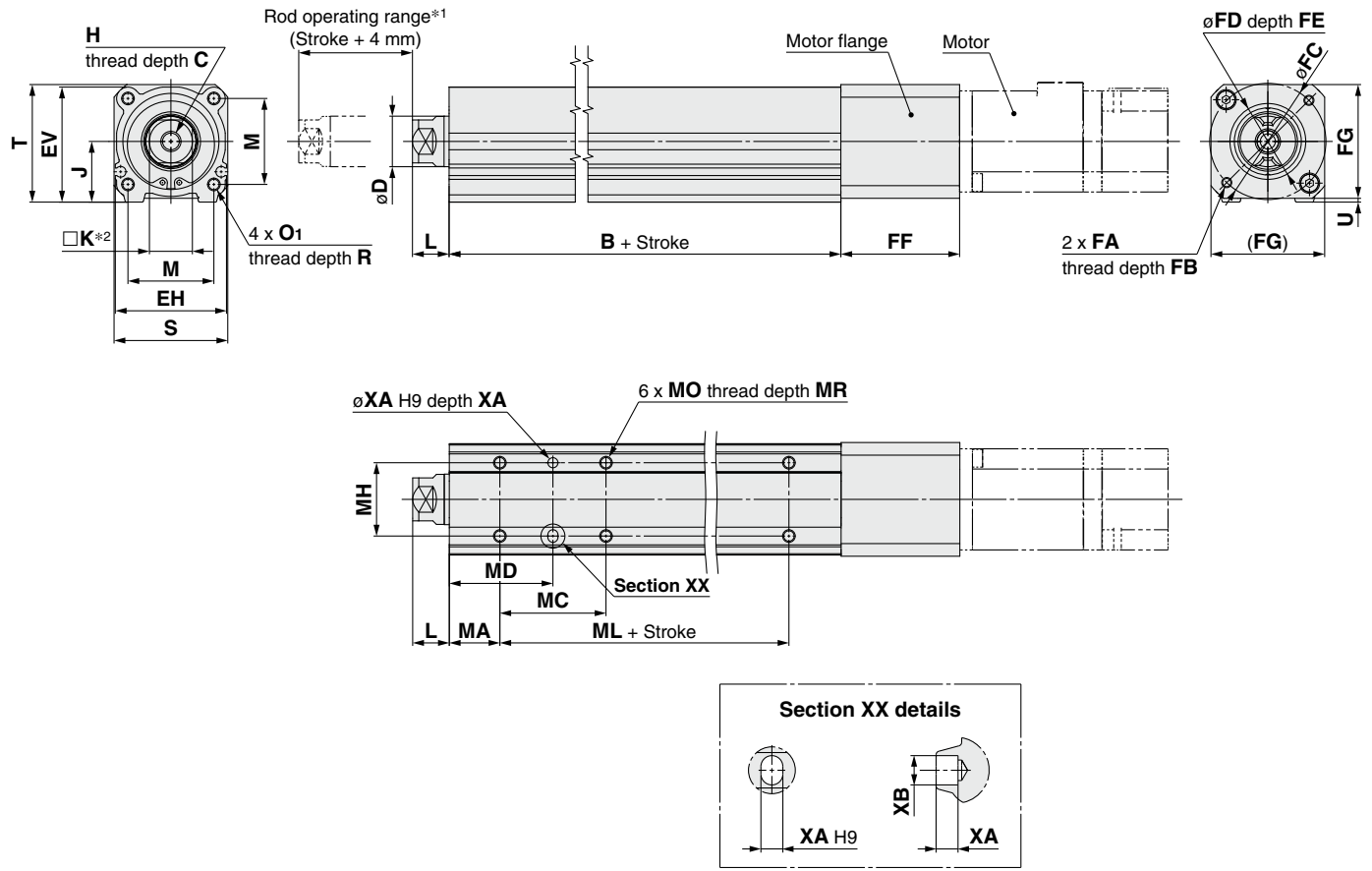

*1 Do not allow collisions at either end of the rod operating range at a speed exceeding "pushing speed." Additionally, when running the positioning operation, do not set within 2 mm of both ends.
*2 The direction of rod end width across flats ($\square K$) differs depending on the products.

Dimensions

Size	Stroke range [mm]	B	C	D	EH	EV	H	J	K	L	M	O ₁	R	S	T	U
25	15 to 100	89.5	13	20	44	45.5	M8 x 1.25	24	17	12.5	34	M5 x 0.8	8	45	46.5	1.5
	105 to 400	114.5														
32	20 to 100	96	13	25	51	56.5	M8 x 1.25	31	22	16.5	40	M6 x 1.0	10	60	61	1
	105 to 500	126														

* The L measurement is when the unit is at the retracted stroke end position.

Size	Stroke range [mm]	MA	MC	MD	MH	ML	MO	MR	XA	XB
25	15 to 35	20	24	32	29	50	M5 x 0.8	6.5	4	5
	40 to 100		42	41		75				
	105 to 120		59	49.5						
	125 to 200		76	58						
	205 to 400		76	58						
32	20 to 35	25	22	36	30	50	M6 x 1.0	8.5	5	6
	40 to 100		36	43		80				
	105 to 120		53	51.5						
	125 to 200		70	60						
	205 to 500		70	60						

- LEFS
- LEFB
- LEJS
- LEJB
- LEL
- LEM
- LEY
- LEYG
- LES
- LESH
- LEPY
- LEPS
- LER
- LEH
- LEY-X5
- 11-LEFS
- 11-LEJS
- 25A-
- LEC
- JXC
- LECS
- LECS-T
- LECY
- Motorless
- LAT3

Refer to the "Motor Mounting" on page 927 for details about motor mounting and included parts.

Dimensions: In-line Motor

LEY25: NM1, NM2

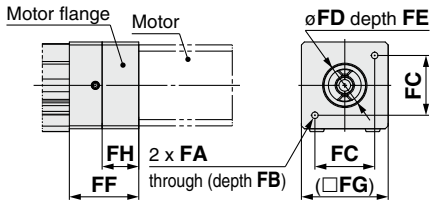

LEY32: NM1

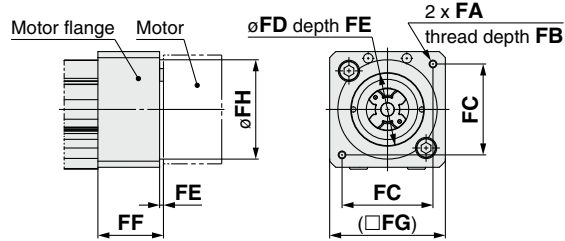

LEY32: NM2

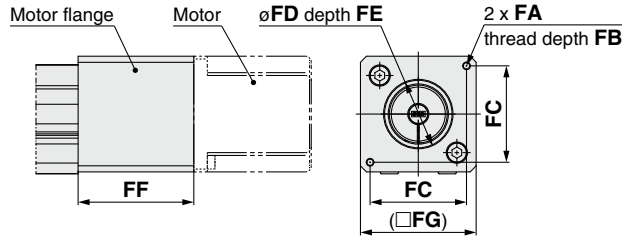

Dimensions

[mm]

Size	Motor type	FA	FB	FC	FD	FE	FF	FG	FH
25	NZ/NX	M4 x 0.7	7.5	46	30	3.7	47	45	—
	NY	M3 x 0.5	6	45	30	4.2	47	45	—
	NM1	ϕ 3.4	17	31	22	2.5	36	45	19
	NM2	ϕ 3.4	28	31	22	2.5	47	45	30
32	NZ/NW/NU/NT	M5 x 0.8	8.5	70	50	3.3	60	60	—
	NY	M4 x 0.7	8	70	50	3.3	60	60	—
	NX	M5 x 0.8	8.5	63	40	3.5	63	60	—
	NV	M4 x 0.7	8	63	40	3.3	63	60	—
	NM1	M4 x 0.7	9.5	47.14	38.1	2	34	60	51.5
	NM2	M4 x 0.7	8	50	36	3.3	60	60	—

Dimensions: In-line Motor

Refer to the "Motor Mounting" on page 928 for details about motor mounting and included parts.

LEY63

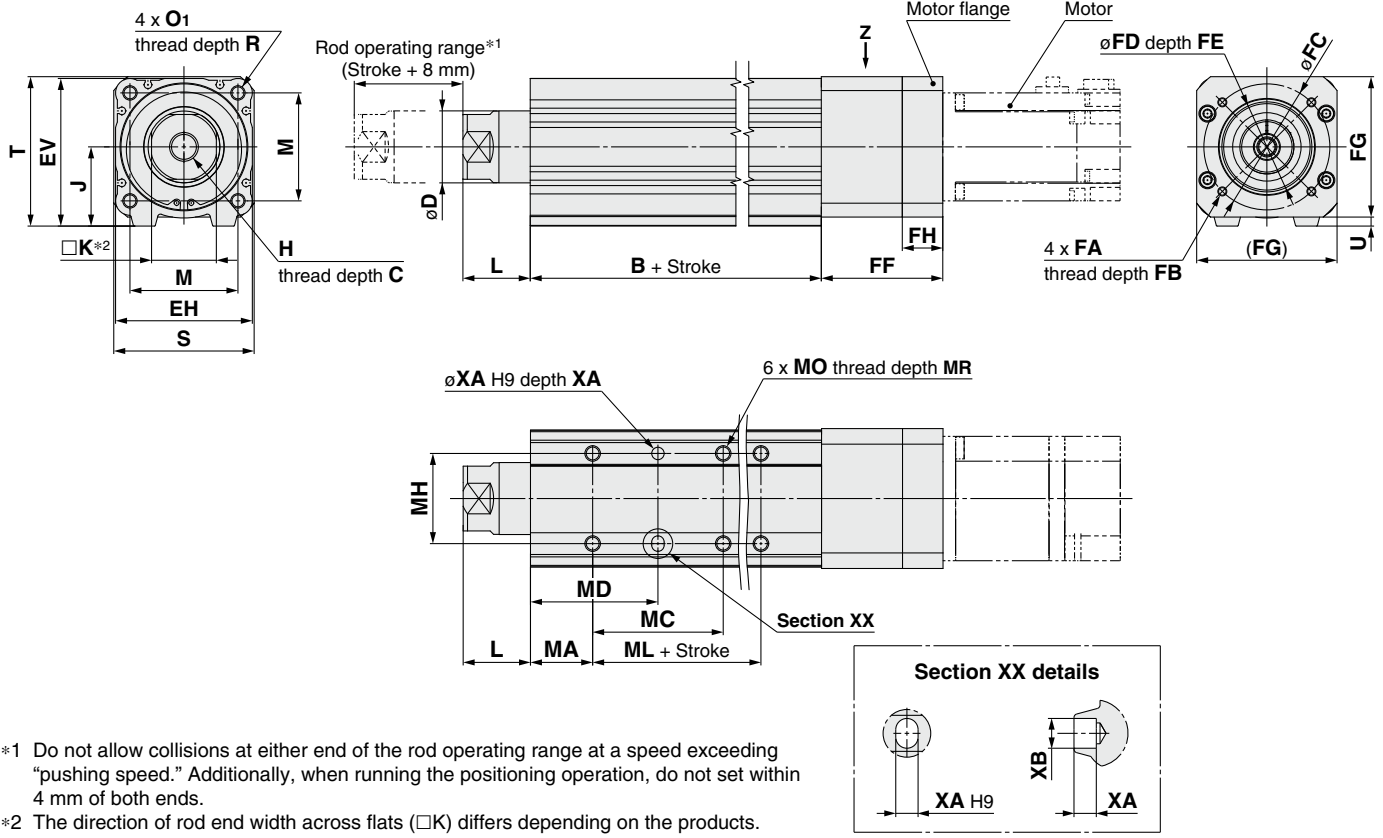

*1 Do not allow collisions at either end of the rod operating range at a speed exceeding "pushing speed." Additionally, when running the positioning operation, do not set within 4 mm of both ends.
*2 The direction of rod end width across flats (□K) differs depending on the products.

IP65 equivalent (Dust-tight/Water-jet-proof): LEY63DN□□-□P (View Z)

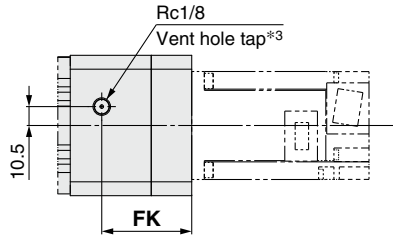

*3 When using the dust-tight/water-jet-proof (IP65 equivalent), correctly mount the fitting and tubing to the vent hole tap, and then place the end of the tubing in an area not exposed to dust or water. The fitting and tubing should be provided separately by the customer. Select [Applicable tubing O.D.: ø4 or more, Connection thread: Rc1/8].

Dimensions

Size	Stroke range [mm]	B	C	D	EH	EV	H	J	K	L	M	O1	R	S	T	U
63	50 to 200	123	21	40	76	82	M16 x 2	44	36	33.4	60	M8 x 1.25	16	78	83	5
	205 to 500	158														
	505 to 800	193														

* The L measurement is when the unit is at the retracted stroke end position.

Size	Stroke range [mm]	MA	MC	MD	MH	ML	MO	MR	XA	XB	
63	50 to 70	38	24	50	44	65	M8 x 1.25	10	6	7	
	75 to 120		45	60.5							
	125 to 200		58	67							
	205 to 500		86	81							100
	505 to 800										135

Size	Motor type	FA	FB	FC	FD	FE	FF	FG	FH	FK
63	NZ/NW/NU/NT	M5 x 0.8	10	70	50	3.5	67.7	78	22.5	50
	NY	M4 x 0.7	8	70	50	3.5	67.7	78	22.5	50
	NX	M5 x 0.8	10	63	40	3.5	72.7	78	27.5	55
	NV	M4 x 0.7	8	63	40	3.5	72.7	78	27.5	55

- LEFS
- LEFB
- LEJS
- LEJB
- LEL
- LEM
- LEY
- LEYG
- LES
- LESH
- LEPY
- LEPS
- LER
- LEH
- LEY-X5
- 11-LEFS
- 11-LEJS
- 25A-
- LEC
- JXC
- LECS
- LECS-T
- LECY
- Motorless
- LAT3

LEY Series

Motorless Type

Size **25, 32, 63**

Dimensions

Rod end male thread: LEY32□□B-□□M
 25 A
 63 C

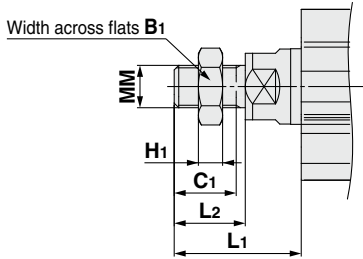

- * Refer to page 361 for details on the rod end nut and mounting bracket.
- * Refer to the precautions on pages 938 and 939 when mounting end brackets such as knuckle joint or workpieces.

Size	B1	C1	H1	L1	L2	MM
25	22	20.5	8	36	23.5	M14 x 1.5
32	22	20.5	8	40	23.5	M14 x 1.5
63	27	26	11	72.4	39	M18 x 1.5

* The L1 measurement is when the unit is at the retracted stroke end position.

Foot: LEY32□□B-□□□L
 25 A
 63 C

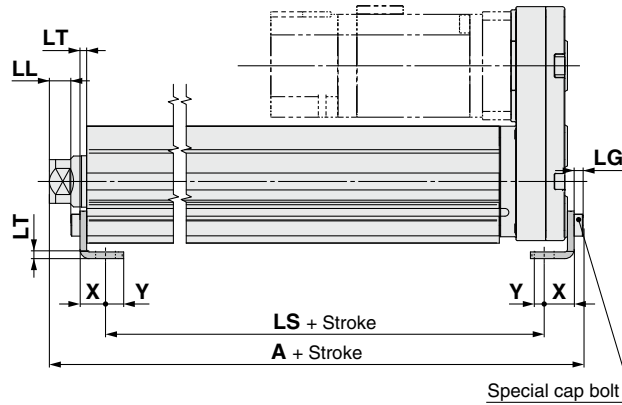
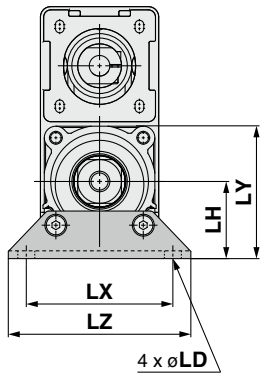

Included parts
 · Foot bracket
 · Body mounting bolt

Outward mounting

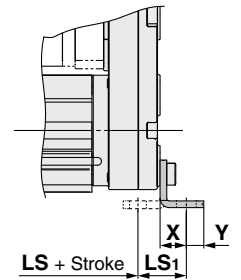

Foot

Size	Stroke range [mm]	A	LS	LS ₁	LL	LD	LG	LH	LT	LX	LY	LZ	X	Y
25	15 to 100	134.6	98.8	19.8	6.4	6.6	3.5	30	2.6	57	51.5	71	11.2	5.8
	105 to 400	159.6	123.8											
32	20 to 100	153.7	114	19.2	9.3	6.6	4	36	3.2	76	61.5	90	11.2	7
	105 to 500	183.7	144											
63	50 to 200	196.8	133.2	25.2	25.2	9	5	50	3.2	95	88	110	14.2	8
	205 to 500	231.8	168.2											
	505 to 800	266.8	203.2											

Material: Carbon steel (Chromating)

* The A and LL measurements are when the unit is at the retracted stroke end position.

* When the motor mounting is the right or left side parallel type, the head side foot bracket should be mounted outward.

Dimensions

Rod flange: LEY32□□B-□□□F
25 A
63 C

Head flange: LEY25□□B-□□□G
A
C

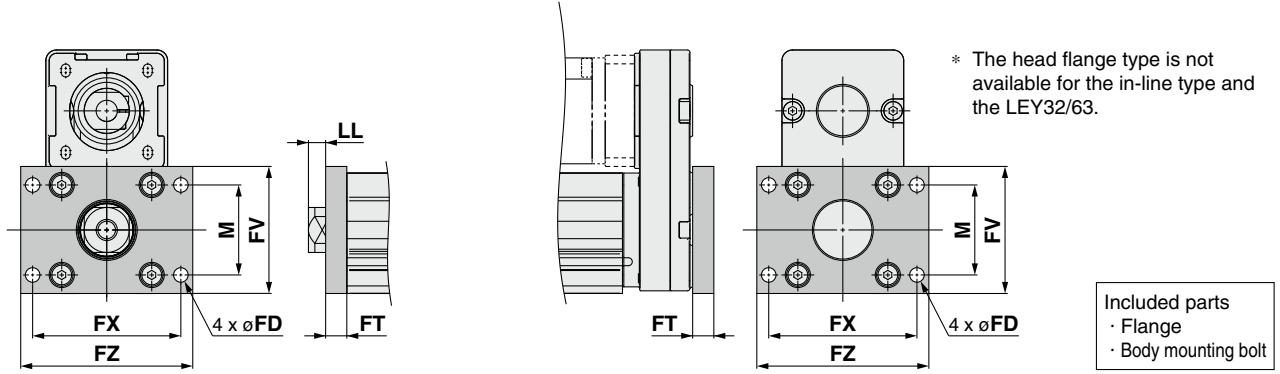

Rod/Head Flange [mm]

Size	FD	FT	FV	FX	FZ	LL	M
25	5.5	8	48	56	65	4.5	34
32	5.5	8	54	62	72	8.5	40
63	9	9	80	92	108	24.4	60

Material: Carbon steel (Nickel plating)

* The LL measurement is when the unit is at the retracted stroke end position.

Double clevis: LEY32□□B-□□□□D
25 A
63 C

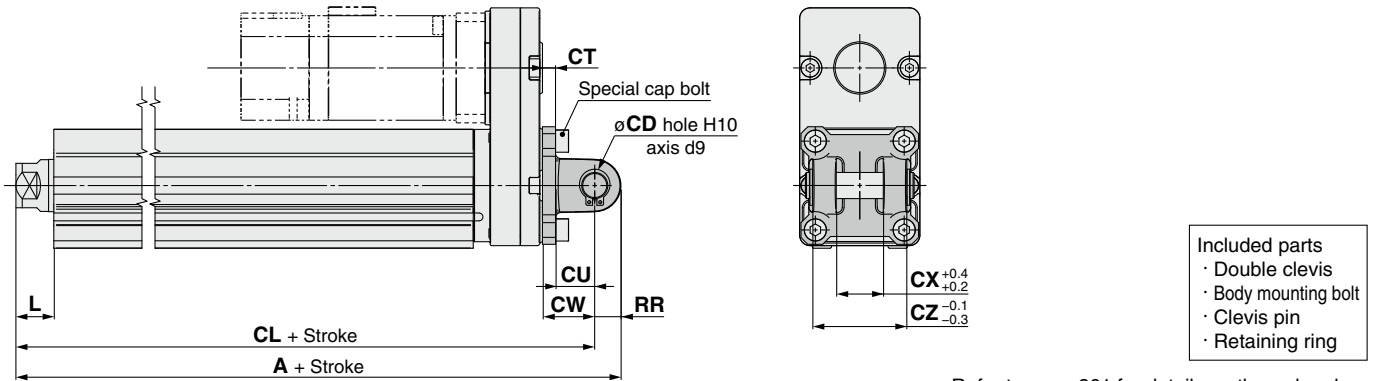

* Refer to page 361 for details on the rod end nut and mounting bracket.

Double Clevis

Size	Stroke range [mm]	A	CL	CD	CT	CU	CW	CX	CZ	L	RR
25	15 to 100	158.5	148.5	10	5	14	20	18	36	12.5	10
	105 to 200	183.5	173.5								
32	20 to 100	178.5	168.5	10	6	14	22	18	36	16.5	10
	105 to 200	208.5	198.5								
63	50 to 200	232.6	218.6	14	8	22	30	22	44	33.4	14
	205 to 300	267.6	253.6								

Material: Cast iron (Coating)

* The A, CL, and L measurements are when the unit is at the retracted stroke end position.

- LEFS
- LEFB
- LEJS
- LEJB
- LEL
- LEM
- LEY
- LEYG
- LES
- LESH
- LEPY
- LEPS
- LER
- LEH
- LEY-X5
- 11-LEFS
- 11-LEJS
- 25A-
- LEC□
- JXC□
- LECS□
- LECS□-T
- LECY□
- Motorless
- LAT3

Model Selection



LEYG Series ▶ p. 921

Moment Load Graph

The model selection method shown below corresponds to SMC's standard motor.
For use in combination with a motor from a different manufacturer, check the available product information of the motor to be used.

Selection Conditions

Mounting orientation		Vertical		Horizontal	
Max. speed [mm/s]		"Speed-Vertical Work Load Graph"		200 or less	Over 200
Bearing	Sliding bearing	Graph ①, ②		Graph ⑤, ⑥*1	Graph ⑦, ⑧
	Ball bushing bearing	Graph ③, ④		Graph ⑨, ⑩	Graph ⑪, ⑫

*1 For the sliding bearing type, the speed is restricted with a horizontal/moment load.

Vertical Mounting, Sliding Bearing

① 70 mm stroke or less

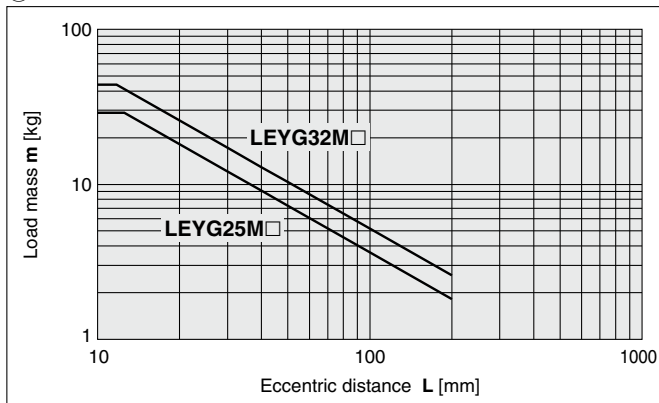

* The limit of vertical load mass varies depending on "lead" and "speed."
Check the "Speed-Vertical Work Load Graph" on page 919.

② Over 75 mm stroke

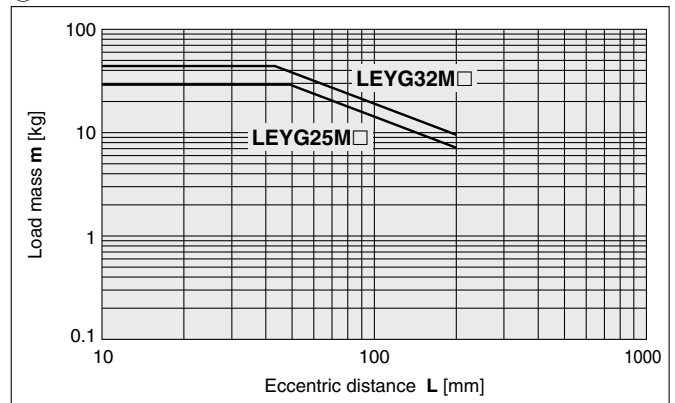

Vertical Mounting, Ball Bushing Bearing

③ 35 mm stroke or less

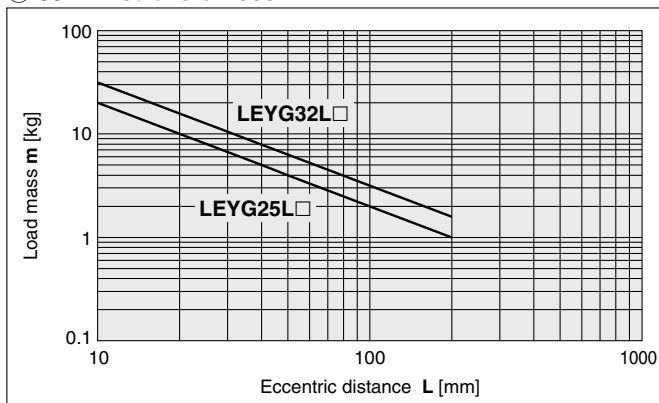

* The limit of vertical load mass varies depending on "lead" and "speed."
Check the "Speed-Vertical Work Load Graph" on page 919.

④ Over 40 mm stroke

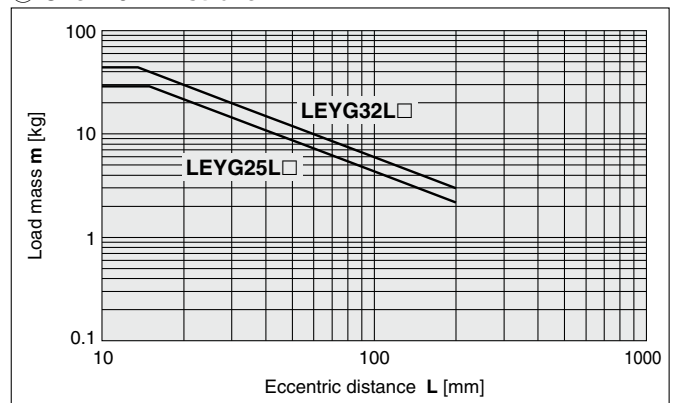

Moment Load Graph

Horizontal Mounting, Sliding Bearing

⑤ L = 50 mm Max. speed = 200 mm/s or less

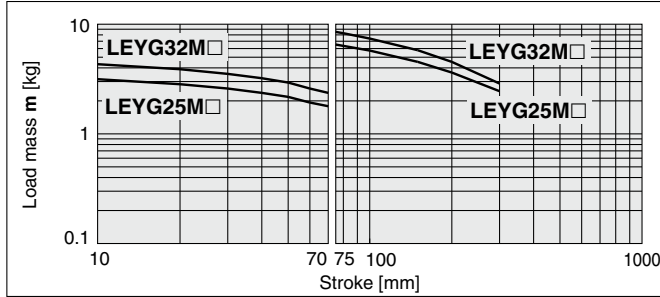

⑥ L = 100 mm Max. speed = 200 mm/s or less

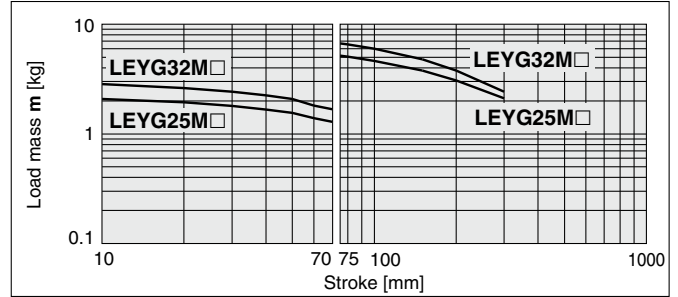

⑦ L = 50 mm Max. speed = Over 200 mm/s

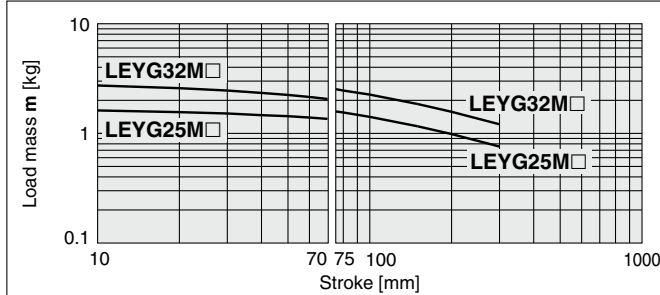

⑧ L = 100 mm Max. speed = Over 200 mm/s

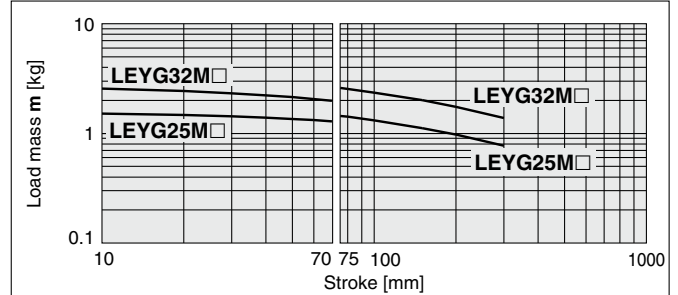

Horizontal Mounting, Ball Bushing Bearing

⑨ L = 50 mm Max. speed = 200 mm/s or less

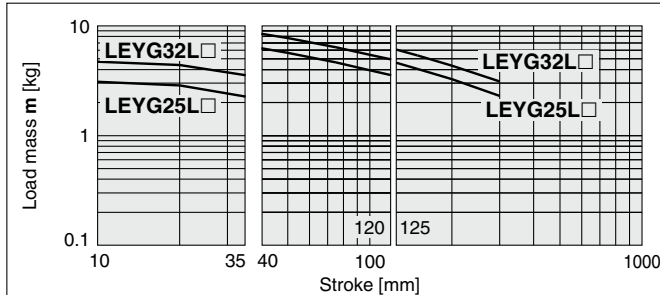

⑩ L = 100 mm Max. speed = 200 mm/s or less

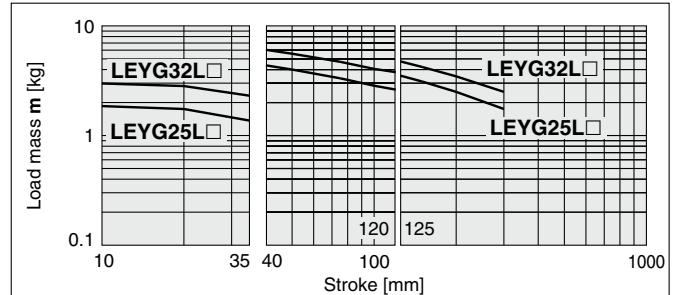

⑪ L = 50 mm Max. speed = Over 200 mm/s

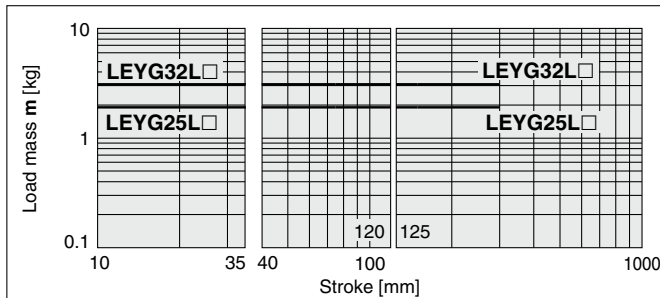

⑫ L = 100 mm Max. speed = Over 200 mm/s

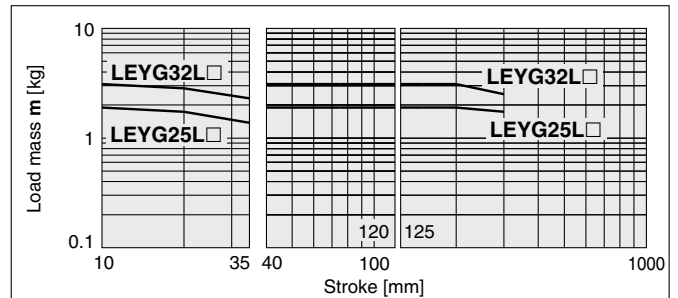

Operating Range when Used as a Stopper

LEYG□M (Sliding bearing)

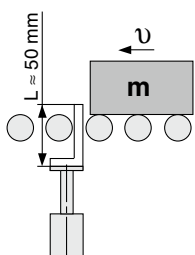

⚠ Caution

Handling Precautions

- * When used as a stopper, select a model with a stroke of 30 mm or less.
- * LEYG□L (ball bushing bearing) cannot be used as a stopper.
- * Workpiece collision in series with guide rod cannot be permitted (Fig. a).
- * The body should not be mounted on the end. It must be mounted on the top or bottom (Fig. b).

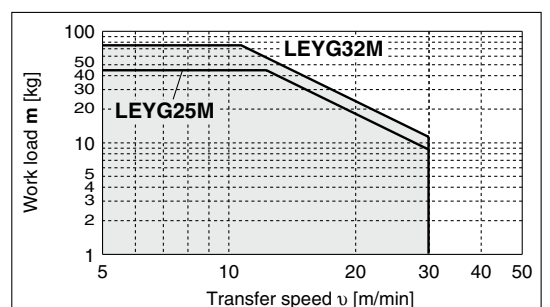
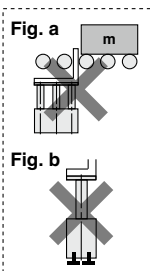

LEYG Series

Motorless Type

Speed-Vertical Work Load Graph

* These graphs show the work load when the external guide is used together. When using the LEYG alone, refer to pages 917 and 918.
 * The values shown below are allowable values of the actuator body. Do not use the actuator so that it exceeds these specification ranges.

LEYG25□ (Motor mounting position: Top mounting/In-line)

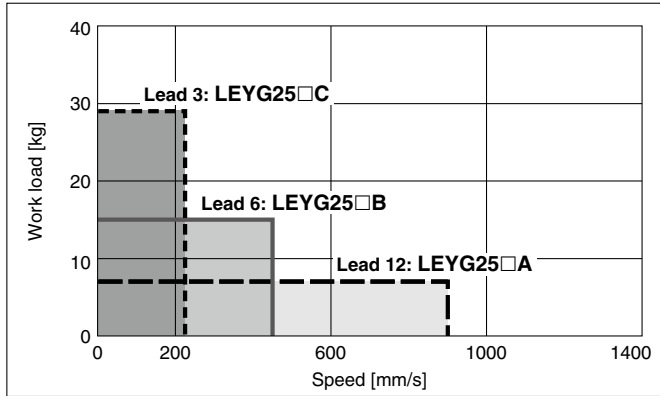

LEYG32□ (Motor mounting position: Top mounting)

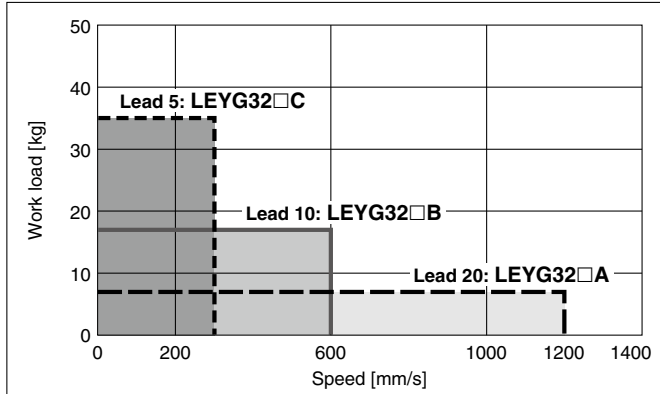

LEYG32D (Motor mounting position: In-line)

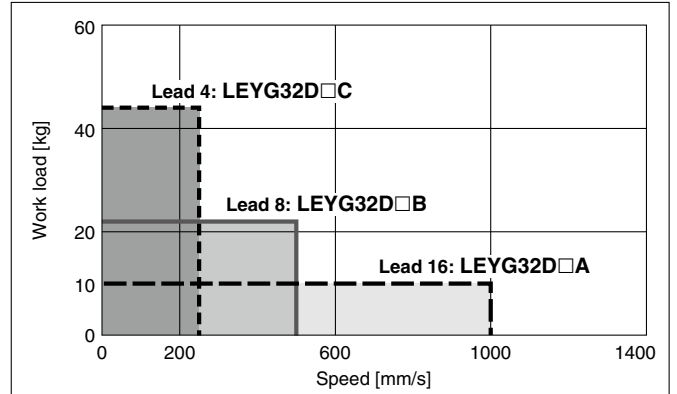

Speed-Horizontal Work Load Graph

* These graphs show the work load when the external guide is used together. When using the LEYG alone, refer to pages 917 and 918.

LEYG25□ (Motor mounting position: Top mounting/In-line)

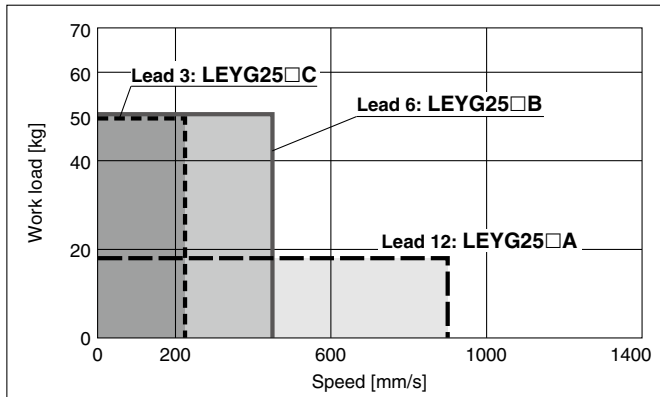

LEYG32□ (Motor mounting position: Top mounting)

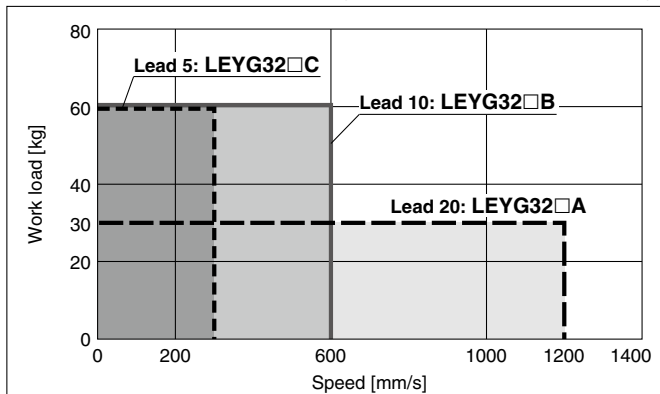

LEYG32D (Motor mounting position: In-line)

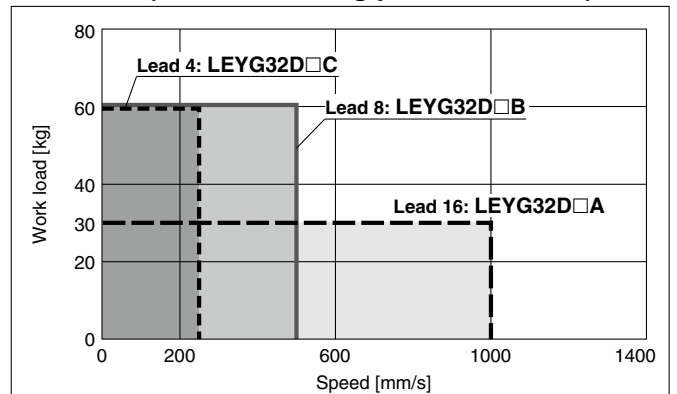

Force Conversion Graph

* These graphs show an example of when the standard motor is mounted. Calculate the force based on used motor and driver.

LEYG25□ (Motor mounting position: Top mounting/In-line)

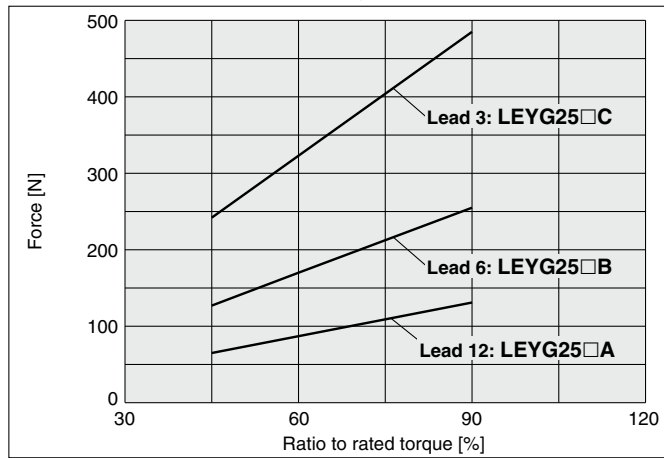

LEYG32□ (Motor mounting position: Top mounting)

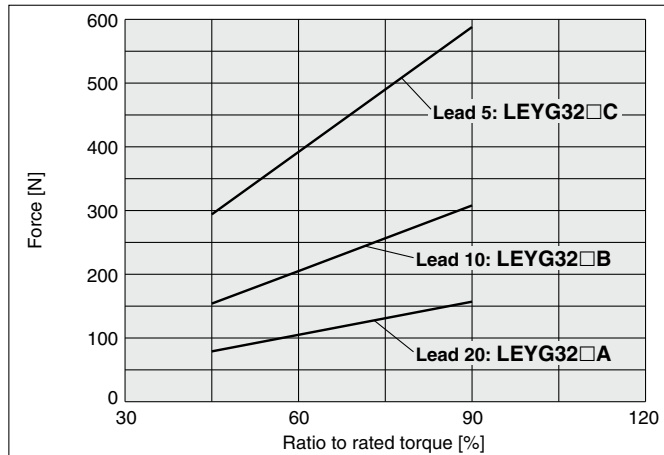

LEYG32D (Motor mounting position: In-line)

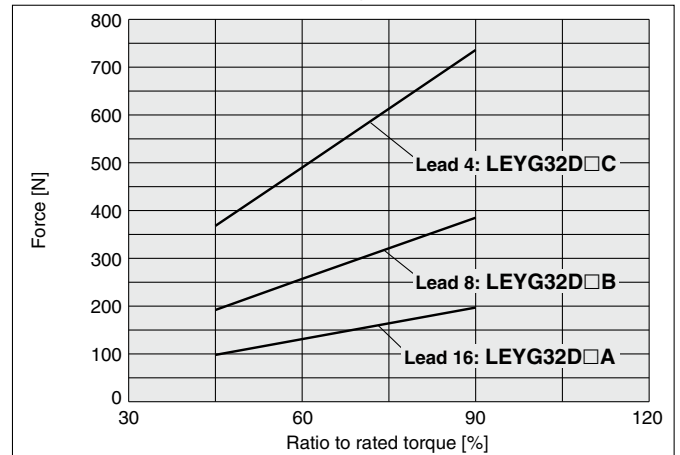

* When using the force control or speed control, set the maximum value to be no more than 90% of the rated torque.

LEFS
LEFB

LEJS
LEJB

LEL

LEM

LEY
LEYG

LES
LESH

LEPY
LEPS

LER

LEH

LEY-X5

11-LEFS

11-LEJS

25A-

LEC□

JXC□

LECS□
LECS□-T

LECY□

Motorless
LAT3

Electric Actuator Guide Rod Type

LEYG Series LEYG25, 32



How to Order

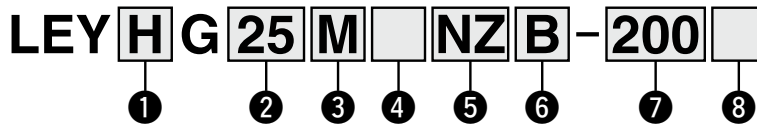

① Accuracy

Nil	Basic type
H	High-precision type

② Size

25
32

③ Bearing type

M	Sliding bearing
L	Ball bushing bearing

④ Motor mounting position

Nil	Top mounting
D	In-line

⑤ Motor type

Symbol	Type
NZ	Mounting type Z
NY	Mounting type Y
NX	Mounting type X
NW	Mounting type W
NV	Mounting type V
NU	Mounting type U
NT	Mounting type T
NM1	Mounting type M1
NM2	Mounting type M2
NM3	Mounting type M3

⑥ Lead [mm]

Symbol	LEYG25	LEYG32*1
A	12	16 (20)
B	6	8 (10)
C	3	4 (5)

*1 The values shown in () are the leads for the size 32 top mounting type. Except motor type NM1 (Equivalent leads which include the pulley ratio [1.25:1])

⑦ Stroke [mm]

30	30
to	to
300	300

* Refer to the applicable stroke table.

⑧ Guide option

Nil	Without option
F	With grease retaining function

* Only available for sliding bearing

* Refer to the "Compatible Motors."

Applicable Stroke Table

Model	Stroke [mm]	● Standard						
		30	50	100	150	200	250	300
LEYG25		●	●	●	●	●	●	●
LEYG32		●	●	●	●	●	●	●

* Please consult with SMC for non-standard strokes as they are produced as special orders.

Use of auto switches for the guide rod type LEYG series

- Auto switches must be inserted from the front side with the rod (plate) sticking out.
- Auto switches cannot be fixed with the parts hidden behind the guide attachment (the side of the rod that sticks out).
- Please consult with SMC when using auto switches on the side of the rod that sticks out, as it is produced as a special order.

For auto switches, refer to pages 933 to 936.

Compatible Motors

Applicable motor model			Size/Motor type															
Manufacturer	Series	Type	25						32									
			NZ Mounting type Z	NY Mounting type Y	NX Mounting type X	NM1 Mounting type M1	NM2 Mounting type M2	NM3 Mounting type M3	NZ Mounting type Z	NY Mounting type Y	NX Mounting type X	NW Mounting type W	NV Mounting type V	NU Mounting type U	NT Mounting type T	NM1 Mounting type M1	NM2 Mounting type M2	
Mitsubishi Electric Corporation	MELSERVO-JN	HF-KN	●	—	—	—	—	—	●	—	—	—	—	—	—	—	—	—
	MELSERVO-J4	HG-KR	●	—	—	—	—	—	●	—	—	—	—	—	—	—	—	—
	MELSERVO-J5	HK-KT	●	—	—	—	—	—	●	—	—	—	—	—	—	—	—	—
YASKAWA Electric Corporation	Σ-V	SGMJV	●	—	—	—	—	—	●	—	—	—	—	—	—	—	—	—
	Σ-7	SGM7J/SGM7A	●	—	—	—	—	—	●	—	—	—	—	—	—	—	—	—
SANYO DENKI CO., LTD.	SANMOTION R	R2	●	—	—	—	—	—	●	—	—	—	—	—	—	—	—	—
OMRON Corporation	Sysmac G5	R88M-K	●	—	—	—	—	—	—	●	—	—	—	—	—	—	—	—
	1 S	R88M-1	●	—	—	—	—	—	—	●	—	—	—	—	—	—	—	—
Panasonic Corporation	MINAS A5	MSM□/MHMD	—	●	—	—	—	—	—	●	—	—	—	—	—	—	—	—
	MINAS A6	MSMF	—	●	—	—	—	—	—	●	—	—	—	—	—	—	—	—
		MHMF	●	—	—	—	—	—	—	●	—	—	—	—	—	—	—	—
FANUC CORPORATION	βis (-B)	β	●	—	—	—	—	—	—	● (β1 only)	—	—	●	—	—	—	—	
NIDEC SANKYO CORPORATION	S-FLAG	MA/MH/MM	●	—	—	—	—	—	—	●	—	—	—	—	—	—	—	—
KEYENCE CORPORATION	SV	SV-M/SV-B	●	—	—	—	—	—	—	●	—	—	—	—	—	—	—	—
	SV2	SV2-M/SV2-B	●	—	—	—	—	—	—	●	—	—	—	—	—	—	—	—
FUJI ELECTRIC CO., LTD.	ALPHA5	GYS/GYB	●	—	—	—	—	—	—	●	—	—	—	—	—	—	—	—
	ALPHA7	GYS/GYB	●	—	—	—	—	—	—	●	—	—	—	—	—	—	—	—
	FALDIC α	GYS	●	—	—	—	—	—	—	●	—	—	—	—	—	—	—	—
MinebeaMitsumi Inc.	SZ	A17PM/A23KM	—	—	—	●*1	—	—	●*2	—	—	—	—	—	—	—	●	—
Shinano Kenshi Co., Ltd.	CSB-BZ	CSB-BZ	—	—	—	●*1	—	—	●*2	—	—	—	—	—	—	—	—	—
ORIENTAL MOTOR Co., Ltd.	AR/AZ	AR/AZ (46 only)	—	—	—	—	—	—	—	●	—	—	—	—	—	—	—	—
	AR/AZ	AR/AZ	—	—	—	—	—	—	—	—	—	—	—	—	—	—	—	●
FASTECH Co., Ltd.	Ezi-SERVO	EzM	—	—	—	●	—	—	—	—	—	—	—	—	—	—	●	
Rockwell Automation, Inc. (Allen-Bradley)	MP-/VP-	MP/VP	—	—	—	—	—	—	—	—	—	—	—	—	—	—	—	—
	TL	TLY-A	●	—	—	—	—	—	—	—	—	—	—	—	—	—	—	●*1
Beckhoff Automation GmbH	AM	AM30	●	—	—	—	—	—	—	—	—	—	—	—	—	—	—	●*1
	AM	AM31	●	—	—	—	—	—	—	—	—	—	—	—	—	—	—	●
	AM	AM80/AM81	●	—	—	—	—	—	—	—	—	—	—	—	—	—	—	—
Siemens AG	1FK7	1FK7	—	—	—	●	—	—	—	—	—	—	—	—	—	—	—	
Delta Electronics, Inc.	ASDA-A2	ECMA	●	—	—	—	—	—	—	—	—	—	—	—	—	—	—	—
ANCA Motion	AMD2000	Alpha	●	—	—	—	—	—	—	—	—	—	—	—	—	—	—	—

*1 Motor mounting position: In-line only *2 Motor mounting position: Top only

Specifications

- Values in this specifications table are the allowable values of the actuator body with the standard motor mounted.
- Do not use the actuator so that it exceeds these values.

Model		LEYG25 ^M (Top mounting) LEYG25 ^M D (In-line)			LEYG32 ^M (Top mounting)			LEYG32 ^M D (In-line)			
Actuator specifications	Work load [kg]	Horizontal ^{*1}	18	50	50	30	60	60	30	60	60
		Vertical	7	15	29	7	17	35	10	22	44
	Force [N] ^{*2} (Set value: Rated torque 30 to 90%)		65 to 131	127 to 255	242 to 485	79 to 157	154 to 308	294 to 588	98 to 197	192 to 385	368 to 736
	Max. speed [mm/s]		900	450	225	1200	600	300	1000	500	250
	Pushing speed [mm/s] ^{*3}		35 or less			30 or less					
	Max. acceleration/deceleration [mm/s ²]		5000								
	Positioning repeatability [mm]	Basic type	±0.02								
		High-precision type	±0.01								
	Lost motion ^{*4} [mm]	Basic type	0.1 or less								
		High-precision type	0.05 or less								
	Ball screw specifications	Thread size [mm]	ø10			ø12					
		Lead [mm] (including pulley ratio)	12	6	3	16 (20)	8 (10)	4 (5)	16	8	4
	Shaft length [mm]		Stroke + 93.5			Stroke + 104.5					
	Impact/Vibration resistance [m/s ²] ^{*5}		50/20								
	Actuation type		Ball screw + Belt (LEY□)			Ball screw + Belt (Pulley ratio 1.25:1)			Ball screw		
Guide type		Sliding bearing (LEYG□M), Ball bushing bearing (LEYG□L)									
Operating temperature range [°C]		5 to 40									
Operating humidity range [%RH]		90 or less (No condensation)									
* Other specifications	Actuation unit weight [kg] (* [ST]: Stroke)	Sliding bearing LEYG□M	0.29 + (2.20 × 10 ⁻³) × [ST]: 185 st or less 0.34 + (1.92 × 10 ⁻³) × [ST]: Over 185 st			0.48 + (2.91 × 10 ⁻³) × [ST]: 180 st or less 0.55 + (2.62 × 10 ⁻³) × [ST]: Over 180 st					
		Ball bushing bearing LEYG□L	0.33 + (1.69 × 10 ⁻³) × [ST]: 110 st or less 0.36 + (1.80 × 10 ⁻³) × [ST]: Over 110 st			0.50 + (2.40 × 10 ⁻³) × [ST]: 110 st or less 0.55 + (2.51 × 10 ⁻³) × [ST]: Over 110 st					
	Other inertia [kg·cm ²]		0.012 (LEYG25) 0.015 (LEYG25D)			0.035 (LEYG32)			0.061 (LEYG32D)		
	Friction coefficient		0.05								
	Mechanical efficiency		0.8								
* Reference motor spec.	Motor shape		□40			□60					
	Motor type		AC servo motor								
	Rated output capacity [W]		100			200					
	Rated torque [N·m]		0.32			0.64					

*1 This is the maximum value of the horizontal work load. An external guide is necessary to support the load (Friction coefficient of guide: 0.1 or less). The actual work load changes according to the condition of the external guide. Confirm the load using the actual device.

*2 The force setting range for the force control (Speed control mode, Torque control mode)

The force changes according to the set value. Set it with reference to the "Force Conversion Graph" on page 920.

*3 The allowable collision speed for collision with the workpiece

*4 A reference value for correcting an error in reciprocal operation

*5 Impact resistance: No malfunction occurred when the actuator was tested with a drop tester in both an axial direction and a perpendicular direction to the lead screw. (The test was performed with the actuator in the initial state.)
Vibration resistance: No malfunction occurred in a test ranging between 45 to 2000 Hz. The test was performed in both an axial direction and a perpendicular direction to the lead screw. (The test was performed with the actuator in the initial state.)

*6 Each value is only to be used as a guide to select a motor of the appropriate capacity.

*7 For other specifications, refer to the specifications of the motor that is to be installed.

Weight

Product Weight

Model	LEYG25 ^M (Motor mounting position: Top mounting)							LEYG32 ^M (Motor mounting position: Top mounting)						
	Stroke [mm]	30	50	100	150	200	250	300	30	50	100	150	200	250
Sliding bearing LEYG□M	1.3	1.5	1.8	2.2	2.6	2.9	3.2	2.2	2.5	3.1	3.8	4.4	4.8	5.3
Ball bushing bearing LEYG□L	1.3	1.5	1.8	2.2	2.5	2.8	3.0	2.2	2.5	2.9	3.6	4.1	4.6	5.0

Model	LEYG25 ^M D (Motor mounting position: In-line)							LEYG32 ^M D (Motor mounting position: In-line)						
	Stroke [mm]	30	50	100	150	200	250	300	30	50	100	150	200	250
Sliding bearing LEYG□M	1.3	1.5	1.8	2.3	2.6	2.9	3.2	2.3	2.5	3.1	3.8	4.4	4.9	5.3
Ball bushing bearing LEYG□L	1.3	1.6	1.8	2.2	2.5	2.8	3.0	2.3	2.5	2.9	3.7	4.1	4.6	5.0

LEYG Series

Motorless Type

Refer to the "Motor Mounting" on page 925 for details about motor mounting and included parts.

Dimensions: Motor Top Mounting

LEYG25, 32

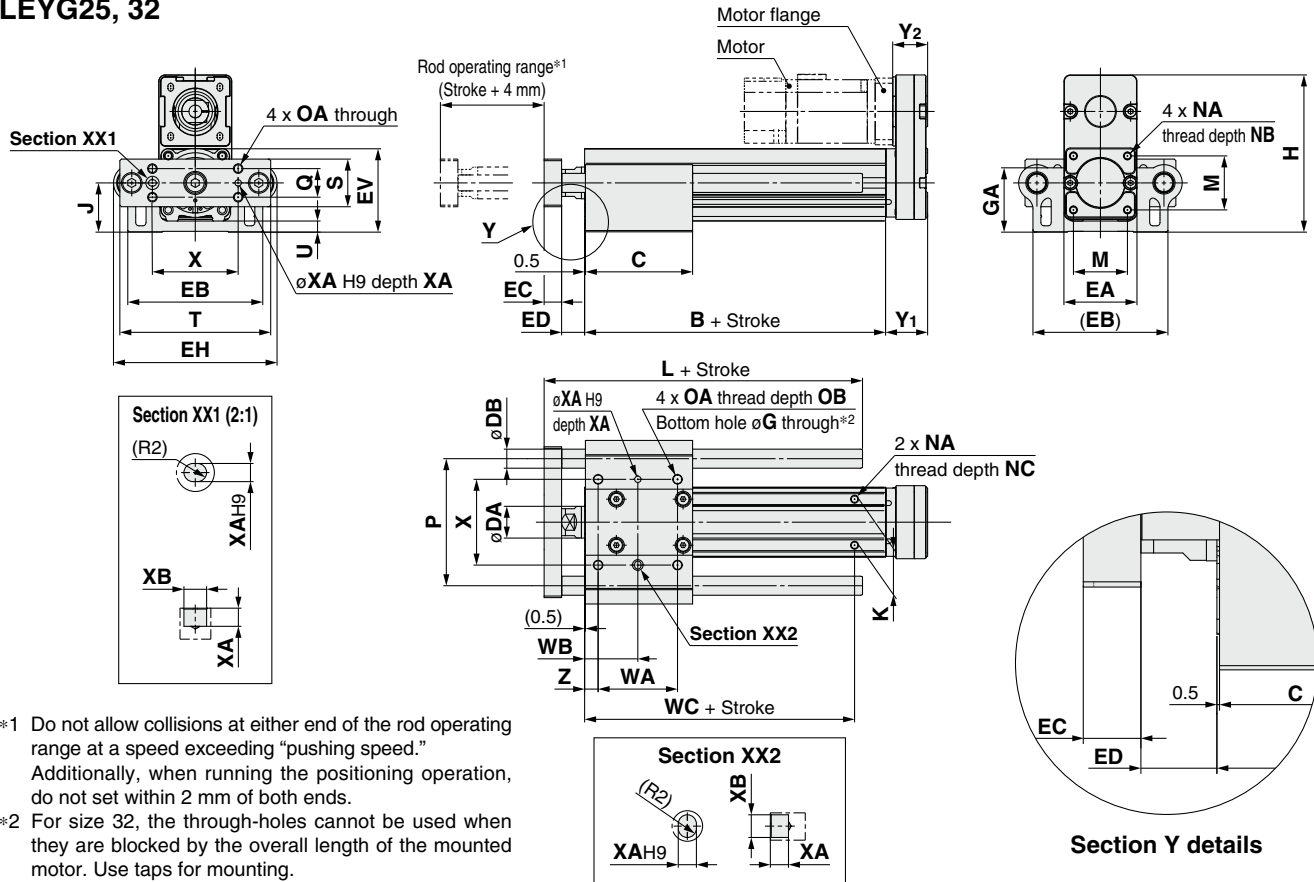

- *1 Do not allow collisions at either end of the rod operating range at a speed exceeding "pushing speed." Additionally, when running the positioning operation, do not set within 2 mm of both ends.
- *2 For size 32, the through-holes cannot be used when they are blocked by the overall length of the mounted motor. Use taps for mounting.

LEYG□L (Ball bushing bearing) [mm]			
Size	Stroke range [mm]	L	DB
25	Up to 110	91	10
	115 to 190	115	
	195 to 300	133	
32	Up to 110	97.5	13
	115 to 190	116.5	
	195 to 300	134	

LEYG□M (Sliding bearing) [mm]			
Size	Stroke range [mm]	L	DB
25	Up to 55	67.5	12
	60 to 185	100.5	
	190 to 300	138	
32	Up to 55	74	16
	60 to 185	107	
	190 to 300	144	

* Refer to page 925 for the dimensions of motor flange.

LEYG□M, LEYG□L Common

[mm]																		
Size	Stroke range [mm]	B	C	DA	EA	EB	EH	EV	EC	ED	G	GA	H	J	K	M	NA	NB
25	Up to 35	89.5	50	20	46	85	103	52.3	11	12.5	5.4	40.3	98.8	30.8	29	34	M5 x 0.8	8
	40 to 100		67.5															
	105 to 120		84.5															
	125 to 200		102															
32	Up to 35	96	55	25	60	101	123	63.8	12	16.5	5.4	50.3	125.3	38.3	30	40	M6 x 1.0	10
	40 to 100		68															
	105 to 120		85															
	125 to 200		102															
Size	Stroke range [mm]	NC	OA	OB	P	Q	S	T	U	WA	WB	WC	X	XA	XB	Y1	Y2	Z
25	Up to 35	6.5	M6 x 1.0	12	80	18	30	95	6.8	35	26	70	54	4	5	26.5	22	8.5
	40 to 100									50	33.5							
	105 to 120																	
	125 to 200																	
32	Up to 35	8.5	M6 x 1.0	12	95	28	40	117	7.3	40	28.5	75	64	5	6	34	27	8.5
	40 to 100									50	33.5							
	105 to 120																	
	125 to 200																	
205 to 300	85	51	95	105														
	85	51																

* The ED measurement is when the unit is at the retracted stroke end position.

Refer to the "Motor Mounting" on page 927 for details about motor mounting and included parts.

Dimensions: In-line Motor

LEYG25, 32

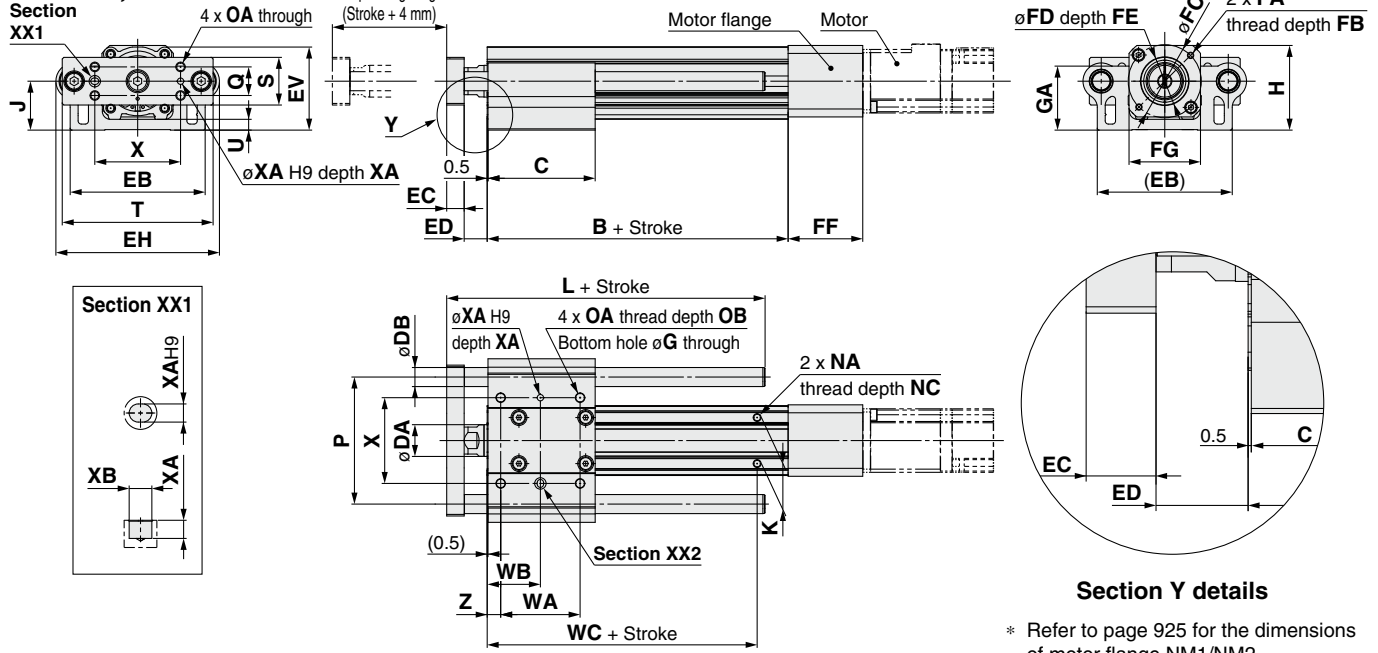

LEYG□L (Ball bushing bearing) [mm]

Size	Stroke range [mm]	L	DB
25	Up to 114	91	10
	115 to 190	115	
	191 to 300	133	
32	Up to 114	97.5	13
	115 to 190	116.5	
	191 to 300	134	

LEYG□M (Sliding bearing) [mm]

Size	Stroke range [mm]	L	DB
25	Up to 55	67.5	12
	60 to 185	100.5	
	190 to 300	138	
32	Up to 55	74	16
	60 to 185	107	
	190 to 300	144	

Dimensions [mm]

Size	Motor type	FA	FB	FC	FD	FE	FF	FG	FH
25	NZ/NX	M4 x 0.7	7.5	46	30	3.7	47	45	—
	NY	M3 x 0.5	6	45	30	4.2	47	45	—
	NM1	ø3.4	17	31	22	2.5	36	45	19
	NM2	ø3.4	28	31	22	2.5	47	45	30
32	NZ/NW/NU/NT	M5 x 0.8	8.5	70	50	3.3	60	60	—
	NY	M4 x 0.7	8	70	50	3.3	60	60	—
	NX	M5 x 0.8	8.5	63	40	3.5	63	60	—
	NV	M4 x 0.7	8	63	40	3.5	63	60	—
32	NM1	M4 x 0.7	9.5	47.14	38.1	2	34	60	51.5
	NM2	M4 x 0.7	8	50	36	3.3	60	60	—

LEYG□M, LEYG□L Common

Size	Stroke range [mm]	B	C	DA	EB	EH	EV	EC	ED	G	GA	H	J	K	NA		
25	Up to 35	89.5	50	20	85	103	52.3	11	12.5	5.4	40.3	53.3	30.8	29	M5 x 0.8		
	40 to 100		67.5														
	105 to 120		84.5														
	125 to 200		102														
32	Up to 35	96	55	25	101	123	63.8	12	16.5	5.4	50.3	68.3	38.3	30	M6 x 1.0		
	40 to 100		68														
	105 to 120		85														
	125 to 200		102														
25	Up to 35	6.5	M6 x 1.0	12	80	18	30	95	6.8	35	26	70	54	4	5	8.5	
	40 to 100									50	33.5						
	105 to 120									70	43.5						
	125 to 200									85	51						
	205 to 300									85	51						
	205 to 300									85	51						
	32	Up to 35	8.5	M6 x 1.0	12	95	28	40	117	7.3	40	28.5	75	64	5	6	8.5
		40 to 100									50	33.5					
		105 to 120									70	43.5					
		125 to 200									85	51					
		205 to 300									85	51					
		205 to 300									85	51					

* The ED measurement is when the unit is at the retracted stroke end position.

- LEFS
- LEFB
- LEJS
- LEJB
- LEL
- LEM
- LEY
- LEYG
- LES
- LESH
- LEPY
- LEPS
- LER
- LEH
- LEY-X5
- 11-LEFS
- 11-LEJS
- 25A-
- LEC□
- JXC□
- LECS□
- LECS□-T
- LECY□
- Motorless
- LAT3

LEY/LEYG Series

Motorless Type

- The motor and motor mounting screws should be provided by the customer.
- Motor shaft type should be cylindrical for the NZ, NY, NW, NM2 motor types, and D-cut type for the NM1 and NM3 motor type.
- When mounting a pulley, remove all oil content, dust, and dirt adhered to the shaft and the inside of the pulley.
- Take measures to prevent the loosening of the motor mounting screws and hexagon socket head set screws.

Motor Mounting: Top/Parallel

LEY25, LEYG25
32, LEYG32

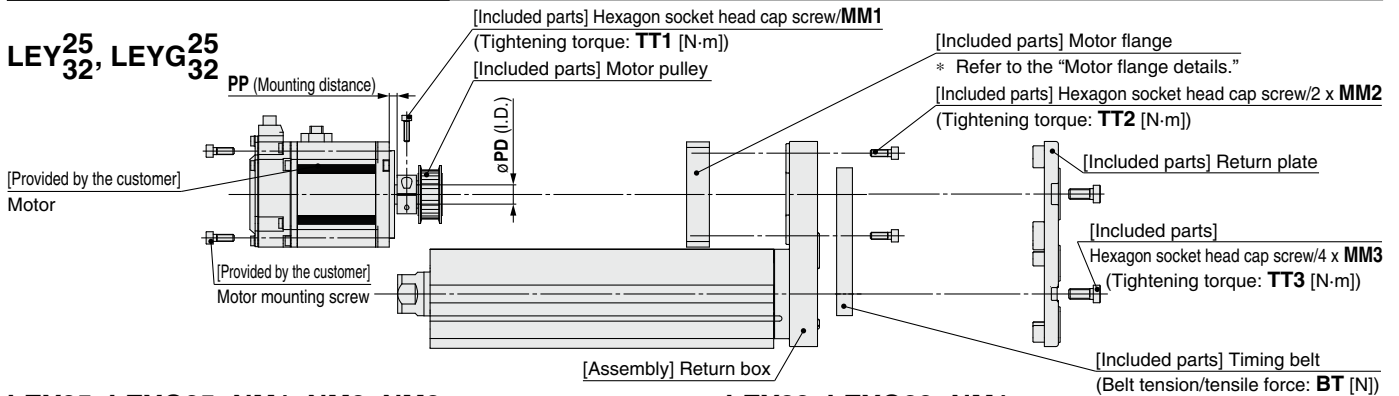

LEY25, LEYG25: NM1, NM2, NM3

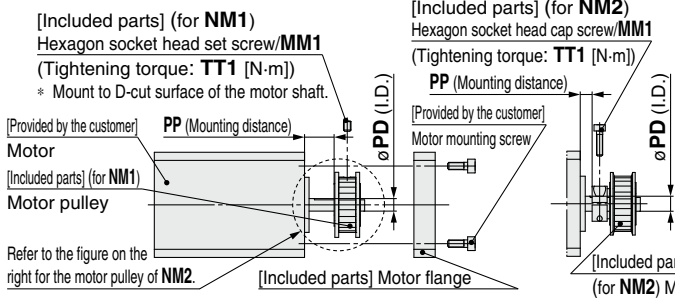

LEY32, LEYG32: NM1

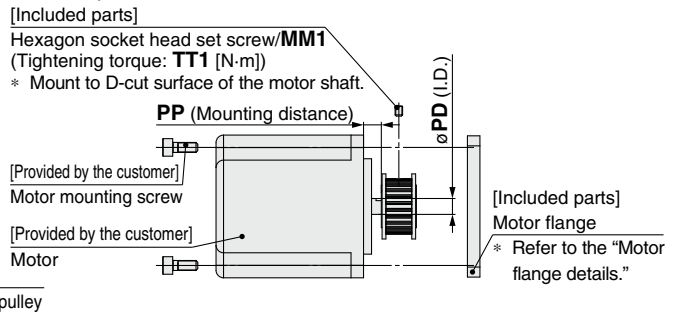

Motor flange details

LEY25: NZ, NY, NX

LEY32: NZ, NY, NW, NU, NT

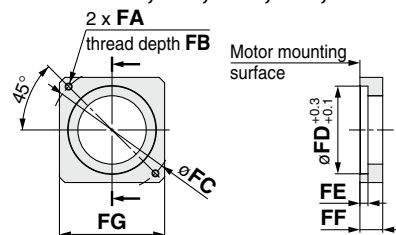

LEY25: NM1, NM2, NM3

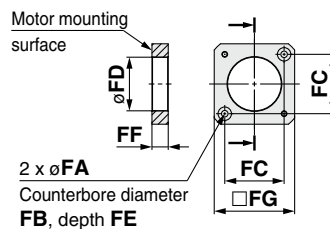

LEY32: NM1, NM2

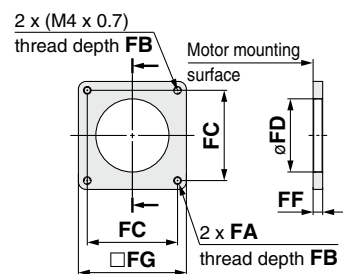

Dimensions

Size	Motor type	MM1	TT1	MM2	TT2	MM3	TT3	PD	PP	BT	FA	FB	FC	FD	FE	FF	FG
25	NZ	M2.5 x 10	1.0	M3 x 8	0.63	M4 x 10	1.5	8	7.5	19	M4 x 0.7	7.5	46	30	3.7	11	42
	NY	M2.5 x 10	1.0	M3 x 8	0.63	M4 x 10	1.5	8	7.5	19	M3 x 0.5	5.5	45	30	5	11	38
	NX	M2.5 x 10	1.0	M3 x 8	0.63	M4 x 10	1.5	8	4.5	19	M4 x 0.7	7	46	30	3.7	8	42
	NM1	M3 x 5	0.63	M3 x 8	0.63	M4 x 10	1.5	5	11.8	19	ø3.4	7	31	28	3.5	8.5	42
	NM2	M2.5 x 10	1.0	M3 x 8	0.63	M4 x 10	1.5	6	4.8	19	ø3.4	7	31	28	3.5	8.5	42
	NM3	M3 x 5	0.63	M3 x 8	0.63	M4 x 10	1.5	5	8.8	19	ø3.4	7	31	28	3.5	5.5	42
32	NZ	M3 x 12	1.5	M4 x 12	1.5	M6 x 14	5.2	14	4.5	30	M5 x 0.8	8.5	70	50	4.6	13	60
	NY	M3 x 12	1.5	M4 x 12	1.5	M6 x 14	5.2	11	4.5	30	M4 x 0.7	7	70	50	4.6	13	60
	NW	M4 x 12	3.6	M4 x 12	1.5	M6 x 14	5.2	9	4.5	30	M5 x 0.8	8.5	70	50	4.6	13	60
	NU	M3 x 12	1.5	M4 x 12	1.5	M6 x 14	5.2	11	4.5	30	M5 x 0.8	8.5	70	50	4.6	13	60
	NT	M3 x 12	1.5	M4 x 12	1.5	M6 x 14	5.2	12	8.5	30	M5 x 0.8	8.5	70	50	4.6	17	60
	NM1	M3 x 5	0.63	M4 x 12	1.5	M6 x 14	5.2	6.35	8	30	M4 x 0.7	(5)	47.1	38.2	—	5	56.4
NM2	M3 x 12	1.5	M4 x 12	1.5	M6 x 14	5.2	10	3	30	M4 x 0.7	8	50	38.2	—	11.5	60	

Motor Mounting Diagram

Mounting procedure

- 1) Secure the motor pulley to the motor (provided by the customer) with the MM1 hexagon socket head cap screw or hexagon socket head set screw.
- 2) Secure the motor to the motor flange with the motor mounting screws (provided by the customer).
- 3) Put the timing belt on the motor pulley and body side pulley, and then secure it temporarily with the MM2 hexagon socket head cap screws. (Refer to the mounting diagram.)
- 4) Apply the belt tension and tighten the timing belt with the MM2 hexagon socket head cap screws. (The reference level is the elimination of the belt deflection.)
- 5) Secure the return plate with the MM3 hexagon socket head cap screws.

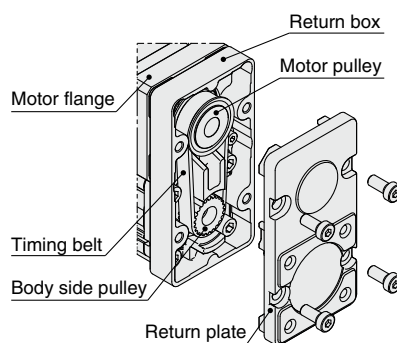

Included Parts List

Size: 25, 32

Description	Quantity	
	Motor type	
	NZ/NY/NW/NT/NM2	NM1/NM3
Motor flange	1	1
Motor pulley	1	1
Return plate	1	1
Timing belt	1	1
Hexagon socket head cap screw (to mount the return plate)	4	4
Hexagon socket head cap screw (to mount the motor flange)	2	2
Hexagon socket head cap screw (to secure the pulley)	1	—
Hexagon socket head set screw (to secure the pulley)	—	1

Motor Mounting: Top/Parallel

LEY63

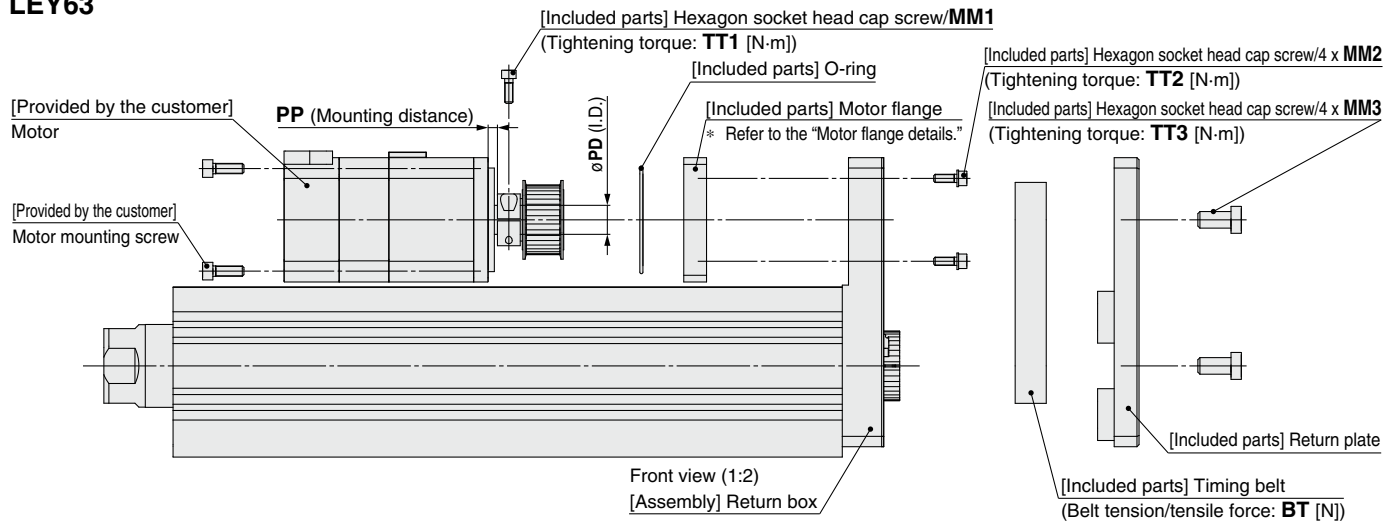

Motor flange details

LEY63: NZ, NY, NW, NT

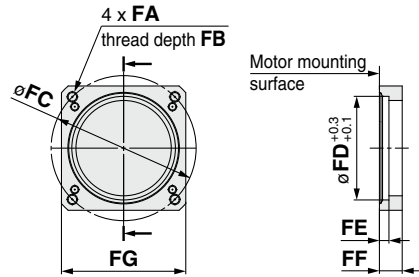

⚠ Be careful about the motor flange mounting direction.

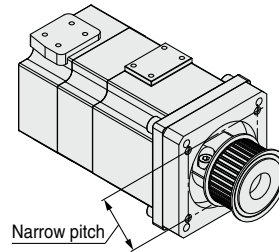

Dimensions

Motor type	MM1	TT1	MM2	TT2	MM3	TT3	PD	PP	BT	FA	FB	FC	FD	FE	FF	FG
NZ	M4 x 12	3.6	M4 x 12	2.7	M8 x 16	12.5	14	4.5	98	M5 x 0.8	8.5	70	50	4.6	11	60
NY	M4 x 12	3.6	M4 x 12	2.7	M8 x 16	12.5	14	4.5	98	M4 x 0.7	8	70	50	4.6	11	60
NW	M4 x 12	3.6	M4 x 12	2.7	M8 x 16	12.5	9	4.5	98	M5 x 0.8	8.5	70	50	4.6	11	60
NT	M4 x 12	3.6	M4 x 12	2.7	M8 x 16	12.5	12	8	98	M5 x 0.8	8.5	70	50	4.6	14.5	60

Motor Mounting Diagram

Mounting procedure

- 1) Secure the motor pulley to the motor (provided by the customer) with the MM1 hexagon socket head cap screw.
- 2) Secure the motor to the motor flange with the motor mounting screws (provided by the customer).
- 3) Put the timing belt on the motor pulley and body side pulley, and then secure it temporarily with the MM2 hexagon socket head cap screws. (Refer to the mounting diagram.)
- 4) Apply the belt tension and tighten the timing belt with the MM2 hexagon socket head cap screws. (The reference level is the elimination of the belt deflection.)
- 5) Secure the return plate with the MM3 hexagon socket head cap screws.

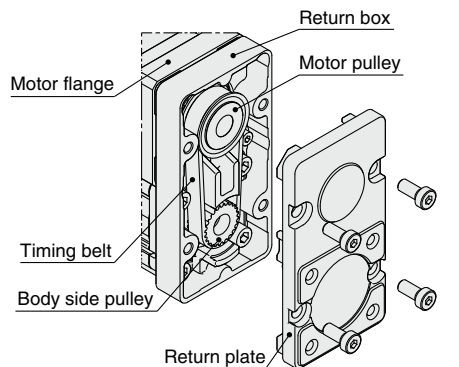

Included Parts List

Size: 63

Description	Quantity	
	Motor type	
	NZ/NY/NW/NT	
Motor flange	1	
Motor pulley	1	
Return plate	1	
Timing belt	1	
Hexagon socket head cap screw (to mount the return plate)	4	
Hexagon socket head cap screw (to mount the motor flange)	4	
Hexagon socket head cap screw (to secure the pulley)	1	
O-ring	1	

LEFS
LEJB
LEJ
LEM
LEYG
LESH
LEPS
LER
LEH
LEY-X5
11-LEFS
11-LEJS
25A-
LEC
JXC
LECS
LECS-T
LECY
Motorless
LAT3

LEY/LEYG Series

Motorless Type

- The motor and motor mounting screws should be provided by the customer.
- Motor shaft type should be cylindrical for the NZ, NY, NX, NW, NM2 motor types, and D-cut type for the NM1 motor type.
- When mounting a hub, remove all oil content, dust, and dirt adhered to the shaft and the inside of the hub.
- Take measures to prevent the loosening of the motor mounting screws and hexagon socket head set screws.

Motor Mounting: In-line

LEY₃₂D, LEYG₃₂□D

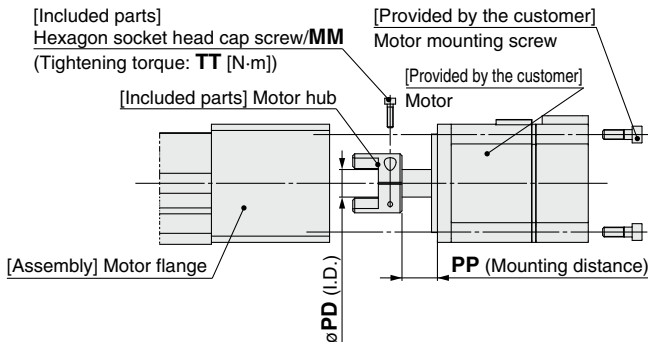

Mounting procedure

- 1) Secure the motor hub to the motor (provided by the customer) with the MM hexagon socket head cap screw.
- 2) Check the motor hub position, and then insert it. (Refer to the mounting diagram.)
- 3) Secure the motor to the motor flange with the motor mounting screws (provided by the customer).

LEY25D, LEYG25□D: NM1

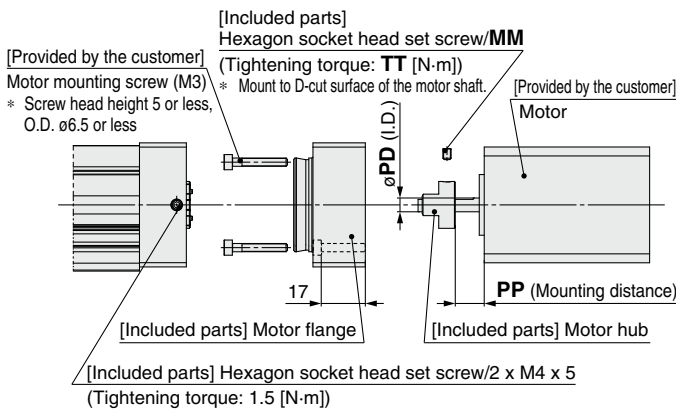

Mounting procedure

- 1) Secure the motor hub to the motor (provided by the customer) with the M3 x 4 hexagon socket head set screw.
- 2) Secure the motor to the motor flange with the motor mounting screws (provided by the customer).
- 3) Check the motor hub position, and then insert it. (Refer to the mounting diagram.)
- 4) Secure the motor flange with the M4 x 5 hexagon socket head set screws.

LEY32D, LEYG32□D: NM1

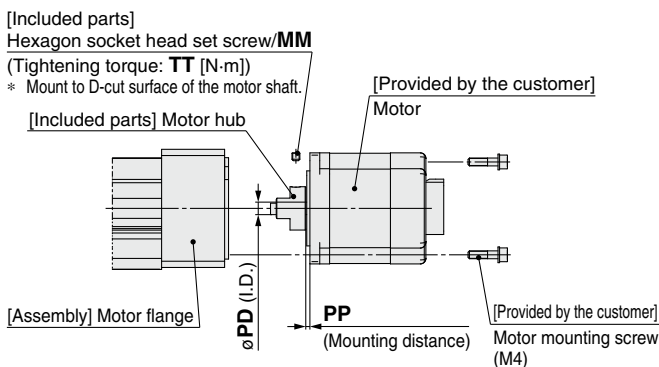

Mounting procedure

- 1) Secure the motor hub to the motor (provided by the customer) with the MM hexagon socket head set screw.
- 2) Check the motor hub position, and then insert it. (Refer to the mounting diagram.)
- 3) Secure the motor to the motor block with the motor mounting screws (provided by the customer).

LEY25D, LEYG25□D: NM2

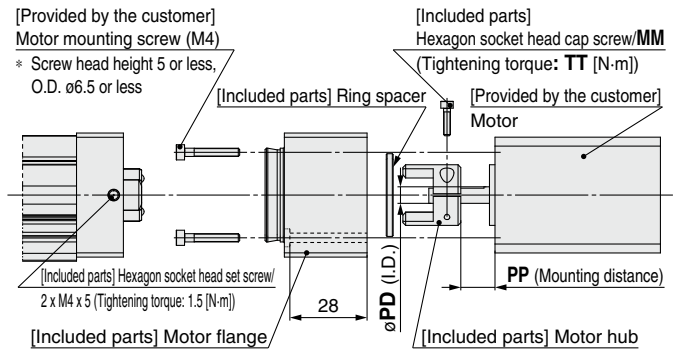

Mounting procedure

- 1) Insert the ring spacer into the motor (provided by the customer).
- 2) Secure the motor hub to the motor (provided by the customer) with the M2.5 x 10 hexagon socket head cap screw.
- 3) Secure the motor to the motor flange with the motor mounting screws (provided by the customer).
- 4) Check the motor hub position, and then insert it. (Refer to the mounting diagram.)
- 5) Secure the motor flange with the M4 x 5 hexagon socket head set screws.

Motor Mounting Diagram

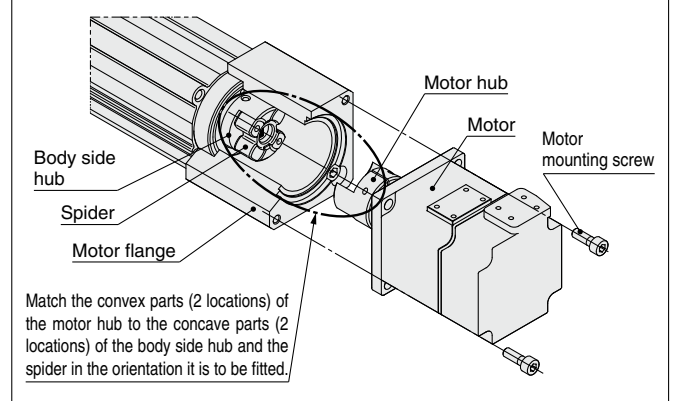

Dimensions

Size	Motor type	MM	TT	PD	PP
25	NZ	M2.5 x 10	1.0	8	12.5
	NY	M2.5 x 10	1.0	8	12.5
	NX	M2.5 x 10	1.0	8	7
	NM1	M3 x 5	0.63	5	10.5
	NM2	M2.5 x 10	1.0	6	12.4
32	NZ	M3 x 12	1.5	14	18
	NY	M4 x 12	3.6	11	18
	NX	M4 x 12	3.6	9	5
	NW	M4 x 12	3.6	9	12
	NV	M4 x 12	3.6	9	5
	NU	M4 x 12	3.6	11	12
	NT	M3 x 12	1.5	12	18
	NM1	M4 x 5	1.5	6.35	2.1
NM2	M4 x 12	3.6	10	12	

Included Parts List

Size: 25

Description	Quantity		
	NZ/NY/NX	NM1	NM2
Motor hub	1	1	1
Hexagon socket head cap screw (to secure the hub)	1	—	1
Motor flange	—	1	1
Hexagon socket head set screw (to secure the hub)	—	1	—
Hexagon socket head set screw (to secure the motor flange)	—	2	2
Ring spacer	—	—	1

Size: 32

Description	Quantity	
	NZ/NY/NX/NW/NV/NU/NT/NM2	NM1
Motor hub	1	1
Hexagon socket head cap screw (to secure the hub)	1	—
Hexagon socket head set screw (to secure the hub)	—	1

- The motor and motor mounting screws should be provided by the customer.
- Prepare a motor with a round shaft end.
- When mounting a hub, remove all oil content, dust, and dirt adhered to the shaft and the inside of the hub.
- Take measures to prevent the loosening of the motor mounting screws.

Motor Mounting: In-line

LEY63D

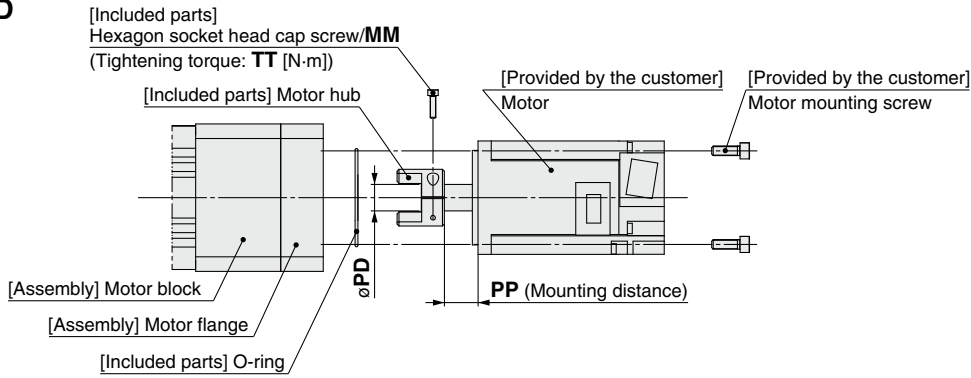

Motor Mounting Diagram

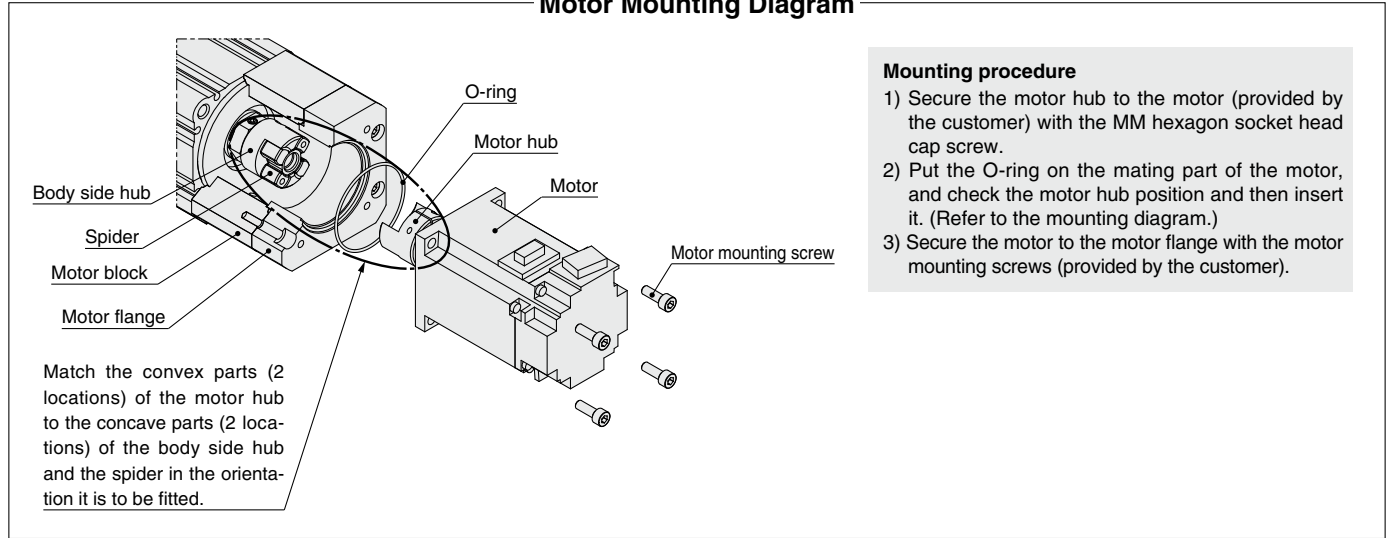

Mounting procedure

- 1) Secure the motor hub to the motor (provided by the customer) with the MM hexagon socket head cap screw.
- 2) Put the O-ring on the mating part of the motor, and check the motor hub position and then insert it. (Refer to the mounting diagram.)
- 3) Secure the motor to the motor flange with the motor mounting screws (provided by the customer).

Dimensions

Size	Motor type	MM	TT	PD	PP
63	NZ	M3 x 12	1.5	14	17.7
	NY				
	NX	M4 x 12	3.6	9	6.7
	NW				11.7
	NV	M4 x 12	3.6	9	6.7
	NU	M4 x 12	3.6	11	11.7
NT	M3 x 12	1.5	12	17.7	

Included Parts List

Size: 63

Description	Quantity
	Motor type
Motor hub	1
Hexagon socket head cap screw (to secure the hub)	1
O-ring	1

LEFS
LEFB

LEJS
LEJB

LEL

LEM

LEY
LEYG

LES
LESH

LEPY
LEPS

LER

LEH

LEY-X5

11-LEFS

11-LEJS

25A-

LEC

JXC

LECS
LECS-T

LECY

Motorless

LAT3

LEY/LEYG Series Motor Mounting Parts

Motor Flange Option

A motor can be added to the motorless specification after purchase. The applicable motor types are shown below. (Except NM1 and NM3)
Use the following part numbers to select a compatible motor flange option and place an order.

How to Order

LEY-MF **25** - **NZ**

①
②
③

① Size

25	For LEY25/LEYG25
32	For LEY32/LEYG32
63	For LEY63

② Motor mounting position

P	Top/Parallel
PL*1	Top/Parallel (Lead L)
D	In-line

*1 Size 63 only

③ Motor type

Symbol	Type	Symbol	Type
NZ	Mounting type Z	NV	Mounting type V
NY	Mounting type Y	NU	Mounting type U
NX	Mounting type X	NT	Mounting type T
NW	Mounting type W	NM2	Mounting type M2

* Refer to the "Compatible Motors."

Compatible Motors

Applicable motor model			Size/Motor type												
Manufacturer	Series	Type	25				32/63								
			NZ Mounting type Z	NY Mounting type Y	NX Mounting type X	NM2 Mounting type M2	NZ Mounting type Z	NY Mounting type Y	NX Mounting type X	NW Mounting type W	NV Mounting type V	NU Mounting type U	NT Mounting type T	NM2 Mounting type M2	
Mitsubishi Electric Corporation	MELSERVO-JN	HF-KN	●	—	—	—	●	—	—	—	—	—	—	—	—
	MELSERVO-J4	HG-KR	●	—	—	—	●	—	—	—	—	—	—	—	—
	MELSERVO-J5	HK-KT	●	—	—	—	●	—	—	—	—	—	—	—	—
YASKAWA Electric Corporation	Σ-V	SGMJV	●	—	—	—	●	—	—	—	—	—	—	—	—
	Σ-7	SGM7J/SGM7A	●	—	—	—	●	—	—	—	—	—	—	—	—
SANYO DENKI CO., LTD.	SANMOTION R	R2	●	—	—	—	●	—	—	—	—	—	—	—	—
OMRON Corporation	Sysmac G5	R88M-K	●	—	—	—	—	●	—	—	—	—	—	—	—
	1 S	R88M-1	●	—	—	—	—	●	—	—	—	—	—	—	—
Panasonic Corporation	MINAS A5	MSM□/MHMD	—	●	—	—	—	●	—	—	—	—	—	—	—
		MSMF	—	●	—	—	—	●	—	—	—	—	—	—	
	MINAS A6	MHMF	●	—	—	—	—	●	—	—	—	—	—	—	—
FANUC CORPORATION	βis (-B)	β	●	—	—	—	● (β1 only)	—	—	●	—	—	—	—	—
NIDEC SANKYO CORPORATION	S-FLAG	MA/MH/MM	●	—	—	—	●	—	—	—	—	—	—	—	—
KEYENCE CORPORATION	SV	SV-M/SV-B	●	—	—	—	●	—	—	—	—	—	—	—	—
	SV2	SV2-M/SV2-B	●	—	—	—	●	—	—	—	—	—	—	—	—
FUJI ELECTRIC CO., LTD.	ALPHA5	GYS/GYB	●	—	—	—	●	—	—	—	—	—	—	—	—
	ALPHA7	GYS/GYB	●	—	—	—	●	—	—	—	—	—	—	—	—
	FALDIC α	GYS	●	—	—	—	●	—	—	—	—	—	—	—	—
ORIENTAL MOTOR Co., Ltd.	AR/AZ	AR/AZ (46 only)	—	—	—	●	—	—	—	—	—	—	—	—	—
	AR/AZ	AR/AZ	—	—	—	—	—	—	—	—	—	—	—	—	●*3
Rockwell Automation, Inc. (Allen-Bradley)	MP-/VP-	MP/VP	—	—	—	—	—	—	—	●*1	—	—	—	—	—
	TL	TLY-A	●	—	—	—	—	—	—	—	—	—	—	●	—
Beckhoff Automation GmbH	AM	AM30	●	—	—	—	—	—	—	—	●*1	—	—	—	—
	AM	AM31	●	—	—	—	—	—	—	—	—	●*2	—	—	—
	AM	AM80/AM81	●	—	—	—	—	—	—	●*1	—	—	—	—	—
Siemens AG	1FK7	1FK7	—	—	●	—	—	—	—	●*1	—	—	—	—	—
Delta Electronics, Inc.	ASDA-A2	ECMA	●	—	—	—	●	—	—	—	—	—	—	—	—
ANCA Motion	AMD2000	Alpha	●	—	—	—	●	—	—	—	—	—	—	—	—

* When the LEY□²⁵□□^{NM1}□□ or LEY□G²⁵□□□□^{NM3}□□ is purchased, it is not possible to change to other motor types.

*1 Motor mounting position: In-line only
*2 Only in-line type is available for size 63.
*3 Except size 63

Dimensions: Motor Flange Option

Motor mounting position: Top/Parallel

Hexagon socket head cap screw: **M1**
(Tightening torque: **T1** [N·m])

Hexagon socket head cap screw: **M2**
(Tightening torque: **T2** [N·m])

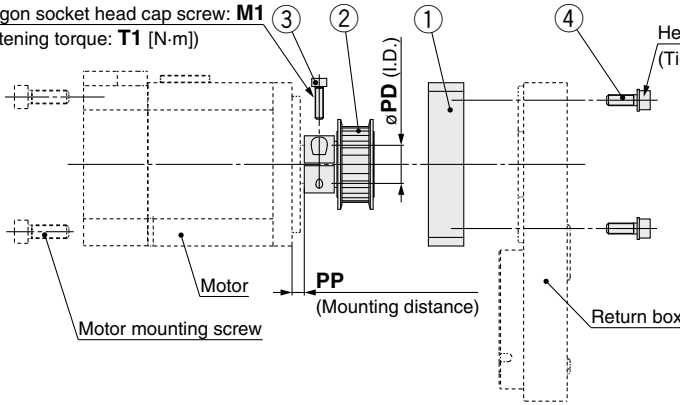

Component Parts

No.	Description	Quantity	
		25, 32	63
1	Motor flange	1	1
2	Motor pulley	1	1
3	Hexagon socket head cap screw (to secure the pulley)	1	1
4	Hexagon socket head cap screw (to mount the motor flange)	2	4

Motor flange details

Size: 25, 32

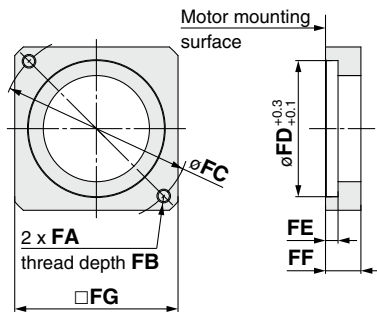

Size 25: NM2

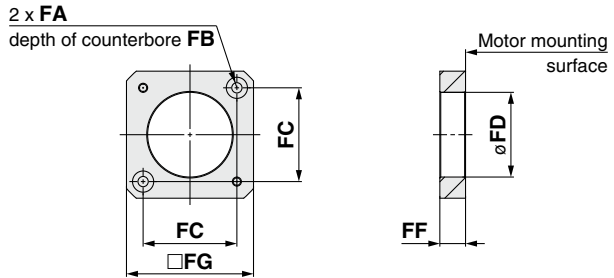

Size: 63

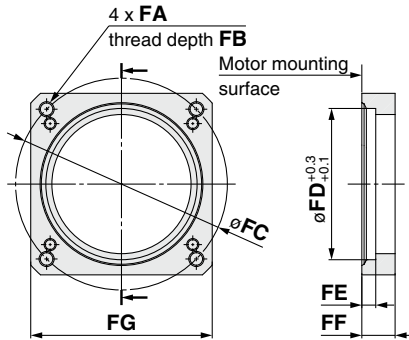

Size 32: NM2

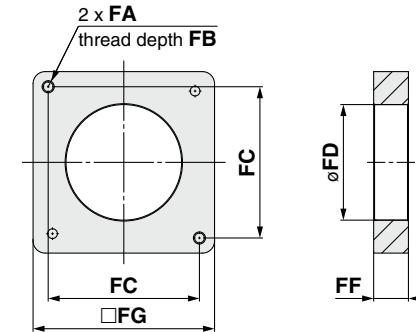

Dimensions

Size	Motor type	FA	FB	FC	FD	FE	FF	FG	M1	T1	M2	T2	PD	PP
25	NZ	M4 x 0.7	7.5	46	30	3.7	11	42	M2.5 x 10	1.0	M3 x 8	0.63	8	7.5
	NY	M3 x 0.5	5.5	45	30	5	11	42	M2.5 x 10	1.0	M3 x 8	0.63	8	7.5
	NX	M4 x 0.7	7	46	30	3.7	8	42	M2.5 x 10	1.0	M3 x 8	0.63	8	4.5
	NM2	ø3.4	7	31	30	3.7	8.5	42	M2.5 x 10	1.0	M3 x 8	0.63	6	4.8
32	NZ	M5 x 0.8	8.5	70	50	4.6	13	60	M3 x 12	1.5	M4 x 12	1.5	14	4.5
	NY	M4 x 0.7	7	70	50	4.6	13	60	M3 x 12	1.5	M4 x 12	1.5	11	4.5
	NW	M5 x 0.8	8.5	70	50	4.6	13	60	M4 x 12	3.6	M4 x 12	1.5	9	4.5
	NU	M5 x 0.8	8.5	70	50	4.6	13	60	M3 x 12	1.5	M4 x 12	1.5	11	4.5
	NT	M5 x 0.8	8.5	70	50	4.6	17	60	M3 x 12	1.5	M4 x 12	1.5	12	8.5
63	NM2	M4 x 0.7	8	50	38.2	—	11.5	60	M3 x 12	1.5	M4 x 12	1.5	10	3
	NZ	M5 x 0.8	8.5	70	50	4.6	11	60	M4 x 12	3.6	M4 x 12	2.7	14	4.5
	NY	M4 x 0.7	8	70	50	4.6	11	60	M4 x 12	3.6	M4 x 12	2.7	14	4.5
	NW	M5 x 0.8	8.5	70	50	4.6	11	60	M4 x 12	3.6	M4 x 12	2.7	9	4.5
	NT	M5 x 0.8	8.5	70	50	4.6	14.5	60	M4 x 12	3.6	M4 x 12	2.7	12	8

LEFS
LEFB
LEJS
LEJB
LEL
LEM
LEY
LEYG
LES
LESH
LEPY
LEPS
LER
LEH
LEY-X5
11-LEFS
11-LEJS
25A-
LEC
JXC
LECS
LECS-T
LECY
Motor/less
LAT3

LEY/LEYG Series

Dimensions: Motor Flange Option

Motor mounting position: In-line [Size: 25, 32]

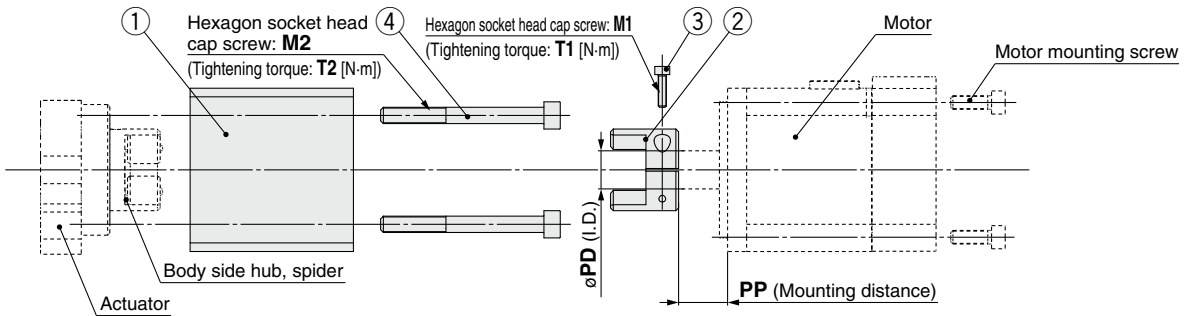

Motor flange details

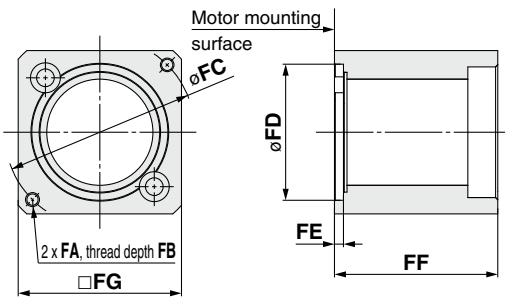

Component Parts

No.	Description	Quantity
1	Motor flange	1
2	Motor hub	1
3	Hexagon socket head cap screw (to secure the hub)	1
4	Hexagon socket head cap screw (to mount the motor block)	2

Size: 25, Motor type: NM2

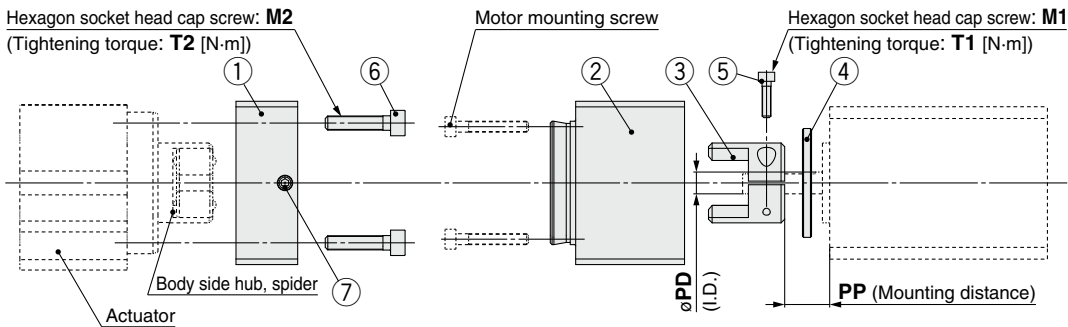

Motor flange B details

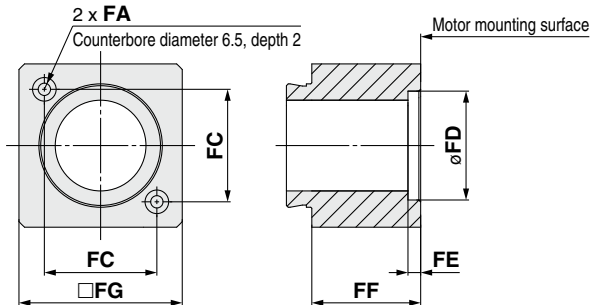

Component Parts

No.	Description	Quantity
1	Motor flange A	1
2	Motor flange B	1
3	Motor hub	1
4	Ring spacer	1
5	Hexagon socket head cap screw (to secure the hub)	1
6	Hexagon socket head cap screw (to mount the motor flange A)	2
7	Hexagon socket head set screw (to secure the motor flange B)	2

Dimensions

Size	Motor type	FA	FB	FC	FD	FE	FF	FG	M1	T1	M2	T2	PD	PP
25	NZ	M4 x 0.7	7.5	46	30	3.7	47	45	M2.5 x 10	1.0	M4 x 40	1.5	8	12.5
	NY	M3 x 0.5	6	45	30	4.2	47	45	M2.5 x 10	1.0	M4 x 40	1.5	8	12.5
	NX	M4 x 0.7	7.5	46	30	3.7	47	45	M2.5 x 10	1.0	M4 x 40	1.5	8	7
	NM2	$\phi 3.4$	28	31	22	2.5	30	45	M2.5 x 10	1.0	M4 x 40	1.5	6	12.4
32	NZ	M5 x 0.8	8.5	70	50	3.3	60	60	M3 x 12	1.5	M6 x 60	5.2	14	18
	NY	M4 x 0.7	8	70	50	3.3	60	60	M4 x 12	3.6	M6 x 60	5.2	11	18
	NX	M5 x 0.8	8.5	63	40	3.5	63	60	M4 x 12	3.6	M6 x 60	5.2	9	5
	NW	M5 x 0.8	8.5	70	50	3.3	60	60	M4 x 12	3.6	M6 x 60	5.2	9	12
	NV	M4 x 0.7	8	63	40	3.3	63	60	M4 x 12	3.6	M6 x 60	5.2	9	5
	NU	M5 x 0.8	8.5	70	50	3.3	60	60	M4 x 12	3.6	M6 x 60	5.2	11	12
	NT	M5 x 0.8	8.5	70	50	3.3	60	60	M3 x 12	1.5	M6 x 60	5.2	12	18
	NM2	M4 x 0.7	8	50	36	3.3	60	60	M4 x 12	3.6	M6 x 60	5.2	10	12

Dimensions: Motor Flange Option

Motor mounting position: In-line [Size: 63]

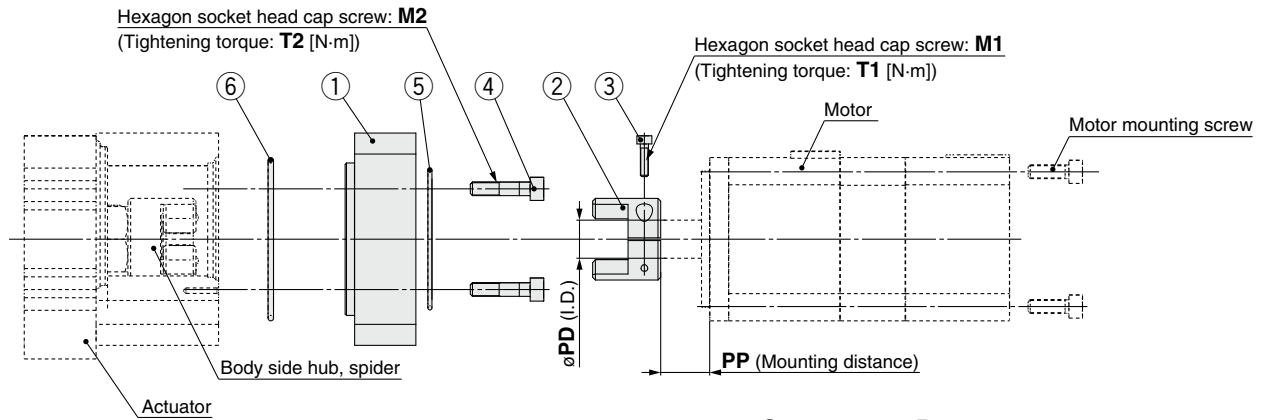

Motor flange details

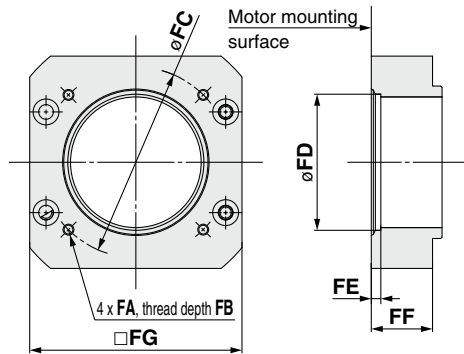

Component Parts

No.	Description	Quantity
1	Motor flange	1
2	Motor hub	1
3	Hexagon socket head cap screw (to secure the hub)	1
4	Hexagon socket head cap screw (to mount the motor adapter)	4
5	O-ring (Wire diameter $\phi 1.5$)	1
6	O-ring (Wire diameter $\phi 2.0$)	1

Dimensions

Size	Motor type	FA	FB	FC	FD	FE	FF	FG	M1	T1	M2	T2	PD	PP
63	NZ	M5 x 0.8	10	70	50	3.5	22.5	78	M3 x 12	1.5	M5 x 22	3	14	17.7
	NY	M4 x 0.7	8	70	50	3.5	22.5	78	M3 x 12	1.5	M5 x 22	3	14	17.7
	NX	M5 x 0.8	10	63	40	3.5	27.5	78	M4 x 12	3.6	M5 x 22	3	9	6.7
	NW	M5 x 0.8	10	70	50	3.5	22.5	78	M4 x 12	3.6	M5 x 22	3	9	11.7
	NV	M4 x 0.7	8	63	40	3.5	27.5	78	M4 x 12	3.6	M5 x 22	3	9	6.7
	NU	M5 x 0.8	10	70	50	3.5	22.5	78	M4 x 12	3.6	M5 x 22	3	11	11.7
	NT	M5 x 0.8	10	70	50	3.5	22.5	78	M3 x 12	1.5	M5 x 22	3	12	17.7

LEFS
LEFB

LEJS
LEJB

LEL

LEM

LEY
LEYG

LES
LESH

LEPY
LEPS

LER

LEH

LEY-X5

11-LEFS

11-LEJS

25A-

LEC

JXC

LECS
LECS-T

LECY

Motorless

LAT3

Solid State Auto Switch Direct Mounting Type D-M9N(V)/D-M9P(V)/D-M9B(V)



Refer to the SMC website for details on products that are compliant with international standards.

Grommet

- 2-wire load current is reduced (2.5 to 40 mA).
- Using flexible cable as standard spec.



Caution

Precautions

Fix the auto switch with the existing screw installed on the auto switch body. The auto switch may be damaged if a screw other than the one supplied is used.

Auto Switch Specifications

PLC: Programmable Logic Controller

D-M9□, D-M9□V (With indicator light)						
Auto switch model	D-M9N	D-M9NV	D-M9P	D-M9PV	D-M9B	D-M9BV
Electrical entry direction	In-line	Perpendicular	In-line	Perpendicular	In-line	Perpendicular
Wiring type	3-wire				2-wire	
Output type	NPN		PNP		—	
Applicable load	IC circuit, Relay, PLC				24 VDC relay, PLC	
Power supply voltage	5, 12, 24 VDC (4.5 to 28 V)				—	
Current consumption	10 mA or less				—	
Load voltage	28 VDC or less		—		24 VDC (10 to 28 VDC)	
Load current	40 mA or less				2.5 to 40 mA	
Internal voltage drop	0.8 V or less at 10 mA (2 V or less at 40 mA)				4 V or less	
Leakage current	100 μA or less at 24 VDC				0.8 mA or less	
Indicator light	Red LED illuminates when turned ON.					
Standard	CE marking, RoHS					

Oilproof Heavy-duty Lead Wire Specifications

Auto switch model		D-M9N(V)	D-M9P(V)	D-M9B(V)
Sheath	Outside diameter [mm]	2.6		
Insulator	Number of cores	3 cores (Brown/Blue/Black)		2 cores (Brown/Blue)
	Outside diameter [mm]	0.88		
Conductor	Effective area [mm ²]	0.15		
	Strand diameter [mm]	0.05		
Minimum bending radius [mm] (Reference values)		17		

- * Refer to page 996 for solid state auto switch common specifications.
- * Refer to page 996 for lead wire lengths.

Weight

[g]

Auto switch model		D-M9N(V)	D-M9P(V)	D-M9B(V)
Lead wire length	0.5 m (Nil)	8	7	7
	1 m (M)	14	13	13
	3 m (L)	41	38	38
	5 m (Z)	68	63	63

Dimensions

[mm]

D-M9□

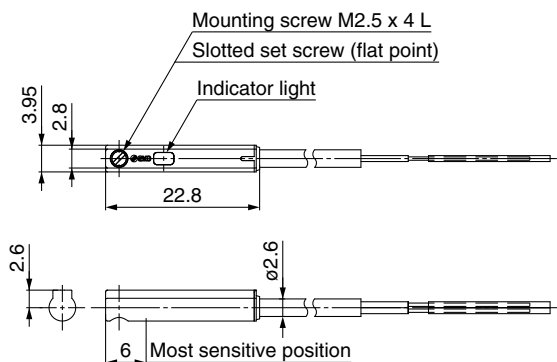

D-M9□V

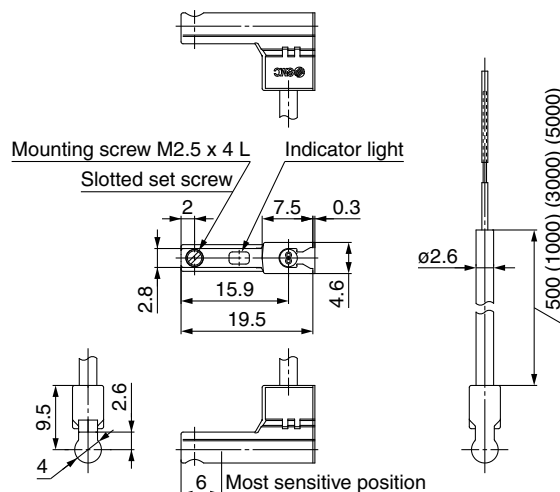

Normally Closed Solid State Auto Switch Direct Mounting Type

D-M9NE(V)/D-M9PE(V)/D-M9BE(V)



Refer to the SMC website for details on products that are compliant with international standards.

Grommet

- Output signal turns on when no magnetic force is detected.
- Can be used for the actuator adopted by the solid state auto switch D-M9 series (excluding special order products)



Caution

Precautions

Fix the auto switch with the existing screw installed on the auto switch body. The auto switch may be damaged if a screw other than the one supplied is used.

Auto Switch Specifications

PLC: Programmable Logic Controller

D-M9□E, D-M9□EV (With indicator light)						
Auto switch model	D-M9NE	D-M9NEV	D-M9PE	D-M9PEV	D-M9BE	D-M9BEV
Electrical entry direction	In-line	Perpendicular	In-line	Perpendicular	In-line	Perpendicular
Wiring type	3-wire				2-wire	
Output type	NPN		PNP		—	
Applicable load	IC circuit, Relay, PLC				24 VDC relay, PLC	
Power supply voltage	5, 12, 24 VDC (4.5 to 28 V)				—	
Current consumption	10 mA or less				—	
Load voltage	28 VDC or less		—		24 VDC (10 to 28 VDC)	
Load current	40 mA or less				2.5 to 40 mA	
Internal voltage drop	0.8 V or less at 10 mA (2 V or less at 40 mA)				4 V or less	
Leakage current	100 μA or less at 24 VDC				0.8 mA or less	
Indicator light	Red LED illuminates when turned ON.					
Standard	CE marking, RoHS					

Oilproof Heavy-duty Lead Wire Specifications

Auto switch model		D-M9NE(V)	D-M9PE(V)	D-M9BE(V)
Sheath	Outside diameter [mm]	2.6		
Insulator	Number of cores	3 cores (Brown/Blue/Black)		2 cores (Brown/Blue)
	Outside diameter [mm]	0.88		
Conductor	Effective area [mm ²]	0.15		
	Strand diameter [mm]	0.05		
Minimum bending radius [mm] (Reference values)		17		

* Refer to page 996 for solid state auto switch common specifications.
* Refer to page 996 for lead wire lengths.

Weight

[g]

Auto switch model		D-M9NE(V)	D-M9PE(V)	D-M9BE(V)
Lead wire length	0.5 m (Nil)	8		7
	1 m (M)*1	14		13
	3 m (L)	41		38
	5 m (Z)*1	68		63

*1 The 1 m and 5 m options are produced upon receipt of order.

Dimensions

[mm]

D-M9□E

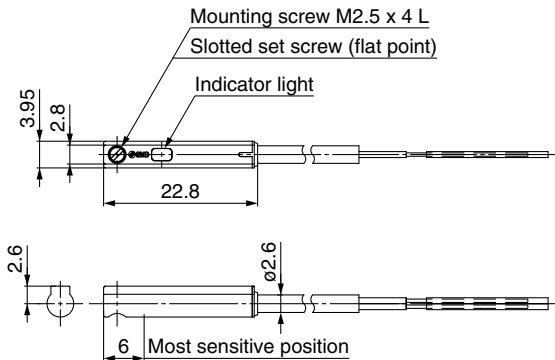

D-M9□EV

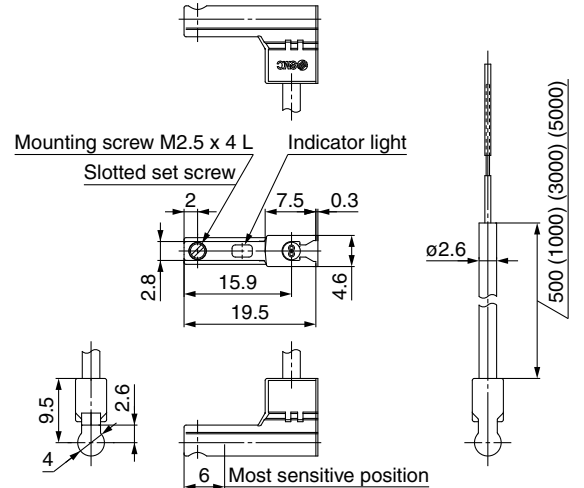

LEFS
LEFB
LEJS
LEJB
LEL
LEM
LEY
LEYG
LES
LESH
LEPY
LEPS
LER
LEH
LEH
LEY-X5
LEF-X5
LEF-X5
11-LEFS
11-LEFS
11-LEJS
25A-
LEC
LEC
JXC
LECS
LECS-T
LECY
Motor/less
LAT3

2-Color Indicator Solid State Auto Switch Direct Mounting Type

D-M9NW(V)/D-M9PW(V)/D-M9BW(V)



Refer to the SMC website for details on products that are compliant with international standards.

PLC: Programmable Logic Controller

Grommet

- 2-wire load current is reduced (2.5 to 40 mA).
- Using flexible cable as standard spec.
- The proper operating range can be determined by the color of the light. (Red → Green ← Red)



Caution

Precautions

Fix the auto switch with the existing screw installed on the auto switch body. The auto switch may be damaged if a screw other than the one supplied is used.

Auto Switch Specifications

D-M9□W, D-M9□WV (With indicator light)						
Auto switch model	D-M9NW	D-M9NWV	D-M9PW	D-M9PWV	D-M9BW	D-M9BWV
Electrical entry direction	In-line	Perpendicular	In-line	Perpendicular	In-line	Perpendicular
Wiring type	3-wire				2-wire	
Output type	NPN		PNP		—	
Applicable load	IC circuit, Relay, PLC				24 VDC relay, PLC	
Power supply voltage	5, 12, 24 VDC (4.5 to 28 V)				—	
Current consumption	10 mA or less				—	
Load voltage	28 VDC or less		—		24 VDC (10 to 28 VDC)	
Load current	40 mA or less				2.5 to 40 mA	
Internal voltage drop	0.8 V or less at 10 mA (2 V or less at 40 mA)				4 V or less	
Leakage current	100 μA or less at 24 VDC				0.8 mA or less	
Indicator light	Operating range Red LED illuminates. Proper operating range Green LED illuminates.					
Standard	CE marking, RoHS					

Oilproof Flexible Heavy-duty Lead Wire Specifications

Auto switch model		D-M9NW(V)	D-M9PW(V)	D-M9BW(V)
Sheath	Outside diameter [mm]	2.6		
Insulator	Number of cores	3 cores (Brown/Blue/Black)		2 cores (Brown/Blue)
	Outside diameter [mm]	0.88		
Conductor	Effective area [mm ²]	0.15		
	Strand diameter [mm]	0.05		
Minimum bending radius [mm] (Reference values)		17		

- * Refer to page 996 for solid state auto switch common specifications.
- * Refer to page 996 for lead wire lengths.

Weight

[g]

Auto switch model		D-M9NW(V)	D-M9PW(V)	D-M9BW(V)
Lead wire length	0.5 m (Nil)	8	7	7
	1 m (M)	14	13	13
	3 m (L)	41	38	38
	5 m (Z)	68	63	63

Dimensions

[mm]

D-M9□W

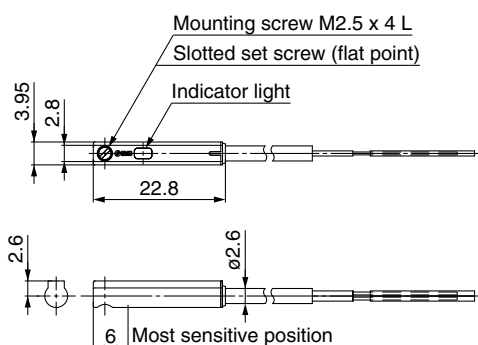

D-M9□WV

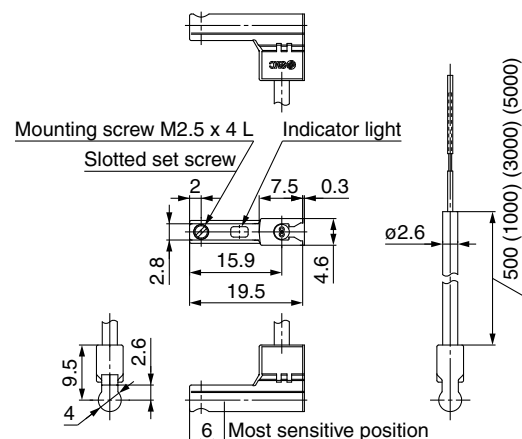

Water Resistant 2-Color Indicator Solid State Auto Switch: Direct Mounting Type D-M9NA(V)/D-M9PA(V)/D-M9BA(V)

Grommet

- Water (coolant) resistant type
- 2-wire load current is reduced (2.5 to 40 mA).
- The proper operating range can be determined by the color of the light. (Red → Green ← Red)
- Using flexible cable as standard spec.

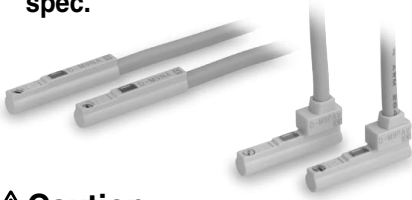

Caution

Precautions

Fix the auto switch with the existing screw installed on the auto switch body. The auto switch may be damaged if a screw other than the one supplied is used. Please consult with SMC if using coolant liquid other than water based solution.

Weight

[g]

Auto switch model	D-M9NA(V)	D-M9PA(V)	D-M9BA(V)
Lead wire length			
0.5 m (Nil)	8	7	
1 m (M)	14	13	
3 m (L)	41	38	
5 m (Z)	68	63	

Dimensions

[mm]

D-M9□A

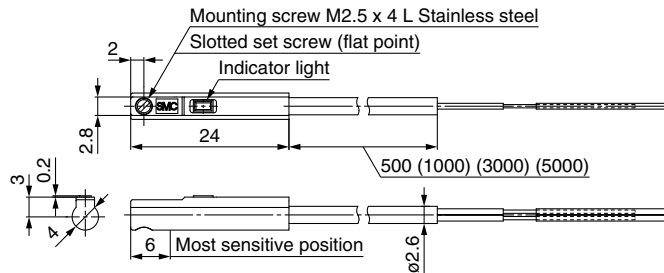

D-M9□AV

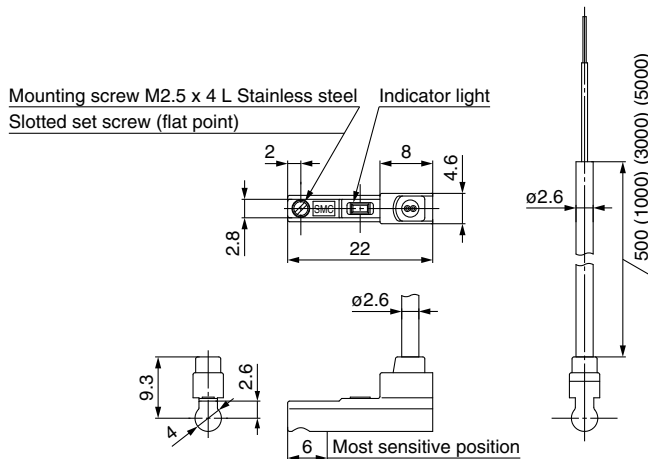

Auto Switch Specifications

PLC: Programmable Logic Controller

D-M9□A, D-M9□AV (With indicator light)						
Auto switch model	D-M9NA	D-M9NAV	D-M9PA	D-M9PAV	D-M9BA	D-M9BAV
Electrical entry direction	In-line	Perpendicular	In-line	Perpendicular	In-line	Perpendicular
Wiring type	3-wire			2-wire		
Output type	NPN		PNP		—	
Applicable load	IC circuit, Relay, PLC				24 VDC relay, PLC	
Power supply voltage	5, 12, 24 VDC (4.5 to 28 V)				—	
Current consumption	10 mA or less				—	
Load voltage	28 VDC or less		—		24 VDC (10 to 28 VDC)	
Load current	40 mA or less				2.5 to 40 mA	
Internal voltage drop	0.8 V or less at 10 mA (2 V or less at 40 mA)				4 V or less	
Leakage current	100 μA or less at 24 VDC				0.8 mA or less	
Indicator light	Operating range Red LED illuminates. Proper operating range Green LED illuminates.					
Standard	CE marking (EMC directive/RoHS directive)					

Oilproof Flexible Heavy-duty Lead Wire Specifications

Auto switch model		D-M9NA□	D-M9NAV□	D-M9PA□	D-M9PAV□	D-M9BA□	D-M9BAV□
Sheath	Outside diameter [mm]	2.6					
Insulator	Number of cores	3 cores (Brown/Blue/Black)			2 cores (Brown/Blue)		
	Outside diameter [mm]	0.88					
Conductor	Effective area [mm ²]	0.15					
	Strand diameter [mm]	0.05					
Minimum bending radius [mm] (Reference values)		17					

* Refer to page 996 for solid state auto switch common specifications.

* Refer to page 996 for lead wire lengths.

LEFS
LEFB

LEJS
LEJB

LEL

LEM

LEY
LEYG

LES
LESH

LEPY
LEPS

LER

LEH

LEH-X5

LEY-X5

11-LEFS

11-LEJS

25A-

LEC□

JXC□

LECS□
LECS□-T

LECY□

Motorless

LAT3



LEY/LEYG Series Specific Product Precautions 1

Be sure to read this before handling the products. Refer to page 984 for safety instructions, pages 985 to 990 for electric actuator precautions, and pages 991 to 1000 for auto switch precautions.

Design / Selection

Warning

- Do not apply a load in excess of the specification limits.**
Select a suitable actuator by work load and allowable lateral load on the rod end. If a load in excess of the specification limits is applied to the piston rod, the generation of play in the piston rod sliding parts, reduced accuracy, etc., may occur and adversely affect the operation and service life of the product.
- Do not use the product in applications where excessive external force or impact force is applied to it.**
This can cause a malfunction.
- When used as a stopper, select the LEYG series "Sliding bearing" for strokes of 30 mm or less.**
- When used as a stopper, fix the main body with a guide attachment ("Top mounting" or "Bottom mounting").**
If the end of the actuator is used to fix the main body (end mounting), the excessive load acts on the actuator, which may adversely affect the operation and service life of the product.

Handling

Caution

- To conduct a pushing operation, be sure to set the product to force/speed control, and use the product within the specified pushing speed range for each series.**
Do not allow the piston rod to hit the workpiece and end of the stroke in the position control. The lead screw, bearing and internal stopper may be damaged and lead to malfunction.
- For pushing operations, the maximum torque value of the motor to be used should be set to 90% or less of the rated torque of the reference motor. For the LEY63, 150% or less.**
Failure to do so may result in damage or malfunction.
- The maximum speed of this actuator is affected by the product stroke.**
Check the model selection section of the catalog.
- Do not apply a load, impact, or resistance in addition to the transferred load during return to origin.**
Additional force will cause the displacement of the origin position.
- Do not scratch or dent the sliding parts of the piston rod by bumping them or placing objects on them.**
The piston rod and guide rod are manufactured to precise tolerances, so even a slight deformation may result in a malfunction.
- When an external guide is used, connect it in such a way that no impact or load is applied to it.**
Use a freely moving connector (such as a floating joint).
- Do not operate by fixing the piston rod and moving the actuator body.**
Excessive load will be applied to the piston rod, resulting in damage to the actuator and a reduced service life of the product.

Handling

Caution

- When an actuator is operated with one end fixed and the other free (ends tapped or flange), a bending moment may act on the actuator due to vibration generated at the stroke end, which can damage the actuator. In such cases, install a mounting bracket to suppress the vibration of the actuator body or reduce the speed so that the actuator does not vibrate at the stroke end.**
Also, use a mounting bracket when moving the actuator body or when a long stroke actuator is mounted horizontally and fixed at one end.
- Avoid using the electric actuator in such a way that rotational torque would be applied to the piston rod.**
Failure to do so may result in the deformation of the non-rotating guide, abnormal auto switch responses play in the internal guide, or an increase in the sliding resistance.
Refer to the table below for the approximate values of the allowable range of rotational torque.

Allowable rotational torque [N·m] or less	LEY25□	LEY32	LEY63
	1.1	1.4	2.8

When screwing a bracket or nut into the piston rod end, hold the flats of the end of the "socket" with a wrench (the piston rod should be fully retracted). Do not apply tightening torque to the non-rotating mechanism.

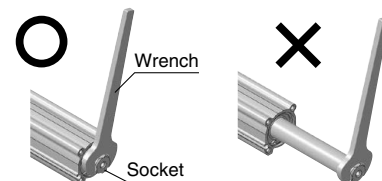

- When using auto switches with the guide rod type LEYG series, the following limits apply. Please consider the following before selecting the product.**
 - Auto switches must be inserted from the front side with the rod (plate) sticking out.
 - Auto switches with perpendicular electrical entries cannot be used.
 - Auto switches cannot be fixed with the parts hidden behind the guide attachment (the side of the rod that sticks out).
 - Please consult with SMC when using auto switches on the side of the rod that sticks out.

Enclosure

IP-□□

First digit • Second digit

- **First Digit: Degree of protection against solid foreign objects**

0	Not protected
1	Protected against solid foreign objects of 50 mmø and larger
2	Protected against solid foreign objects of 12 mmø and larger
3	Protected against solid foreign objects of 2.5 mmø and larger
4	Protected against solid foreign objects of 1.0 mmø and larger
5	Dust protected
6	Dust-tight



LEY/LEYG Series Specific Product Precautions 2

Be sure to read this before handling the products. Refer to page 984 for safety instructions, pages 985 to 990 for electric actuator precautions, and pages 991 to 1000 for auto switch precautions.

Enclosure

• Second Digit: Degree of protection against water

0	Not protected	—
1	Protected against vertically falling water droplets	Dripproof type 1
2	Protected against vertically falling water droplets when enclosure is tilted up to 15°	Dripproof type 2
3	Protected against rainfall when enclosure tilted up to 60°	Rainproof type
4	Protected against splashing water	Splashproof type
5	Protected against water jets	Water-jet-proof type
6	Protected against powerful water jets	Powerful water-jet-proof type
7	Protected against the effects of temporary immersion in water	Immersible type
8	Protected against the effects of continuous immersion in water	Submersible type

Example) IP65: Dust-tight, Water-jet-proof type
 “Water-jet-proof” means that no water enters the equipment that could hinder it from operating normally when water is applied for 3 minutes in the prescribed manner. Take appropriate protective measures as the device is not usable in environments where droplets of water are splashed constantly.

Mounting

⚠ Caution

- When mounting workpieces or jigs to the piston rod end “socket,” hold the flats of the “socket” with a wrench so that the piston rod does not rotate. The bolt should be tightened within the specified torque range.

Failure to do so may cause abnormal auto switch responses, play in the internal guide, or an increase in the sliding resistance.

- When mounting the product and/or a workpiece, tighten the mounting screws within the specified torque range.

Tightening the screws with a higher torque than recommended may result in a malfunction, while tightening with a lower torque can result in the displacement of the mounting position or, in extreme conditions, the actuator could become detached from its mounting position.

<LEY Series>

Workpiece fixed/Rod end female thread

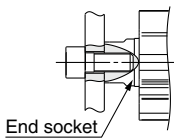

Model	Screw size	Max. tightening torque [N·m]	Max. screw-in depth [mm]	End socket width across flats [mm]
LEY25	M8 x 1.25	12.5	13	17
LEY32	M8 x 1.25	12.5	13	22
LEY63	M16 x 2	106	21	36

Workpiece fixed/Rod end male thread (When “Rod end male thread” is selected.)

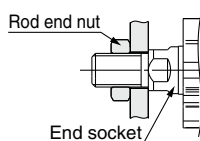

Model	Thread size	Max. tightening torque [N·m]	Effective thread length [mm]	End socket width across flats [mm]
LEY25	M14 x 1.5	65.0	20.5	17
LEY32	M14 x 1.5	65.0	20.5	22
LEY63	M18 x 1.5	97.0	26	36

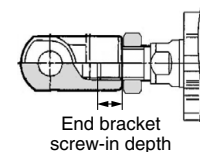

Model	Rod end nut		End bracket screw-in depth [mm]
	Width across flats [mm]	Length [mm]	
LEY25	22	8	8 or more
LEY32	22	8	8 or more
LEY63	27	11	11 or more

* Rod end nut is an accessory.

Mounting

⚠ Caution

Body fixed/Body bottom tapped type (When “Body bottom tapped” is selected.)

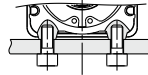

Model	Screw size	Max. tightening torque [N·m]	Max. screw-in depth [mm]
LEY25	M5 x 0.8	3.0	6.5
LEY32	M6 x 1.0	5.2	8.8
LEY63	M8 x 1.25	12.5	10

Body fixed/Rod side/Head side tapped type

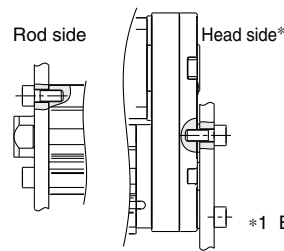

Model	Screw size	Max. tightening torque [N·m]	Max. screw-in depth [mm]
LEY25	M5 x 0.8	3.0	8
LEY32	M6 x 1.0	5.2	10
LEY63	M8 x 1.25	12.5	14

*1 Excludes the LEY□D

<LEYG Series>

Workpiece fixed/Plate tapped type

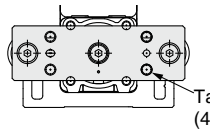

Model	Screw size	Max. tightening torque [N·m]	Max. screw-in depth [mm]
LEYG25 ^M _L	M6 x 1.0	5.2	11
LEYG32 ^M _L	M6 x 1.0	5.2	12

Body fixed/Top mounting

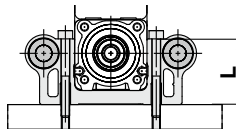

Model	Screw size	Max. tightening torque [N·m]	Length: L [mm]
LEYG25 ^M _L	M5 x 0.8	3.0	40.3
LEYG32 ^M _L	M5 x 0.8	3.0	50.3

Body fixed/Bottom mounting

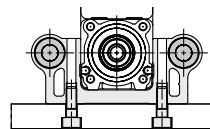

Model	Screw size	Max. tightening torque [N·m]	Max. screw-in depth [mm]
LEYG25 ^M _L	M6 x 1.0	5.2	12
LEYG32 ^M _L	M6 x 1.0	5.2	12

Body fixed/Head side tapped type

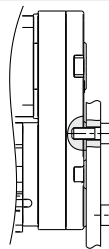

Model	Screw size	Max. tightening torque [N·m]	Max. screw-in depth [mm]
LEYG25 ^M _L	M5 x 0.8	3.0	8
LEYG32 ^M _L	M6 x 1.0	5.2	10

LEFS
LEFB

LEJS
LEJB

LEL

LEM

LEY
LEYG

LES
LESH

LEPY
LEPS

LER

LEH
LEH

LEY-X5

11-LEFS

11-LEJS

25A-

LEC□

JXC□

LECS□
LECS□-T

LECY□

Motorless

LAT3



LEY/LEYG Series Specific Product Precautions 3

Be sure to read this before handling the products. Refer to page 984 for safety instructions, pages 985 to 990 for electric actuator precautions, and pages 991 to 1000 for auto switch precautions.

Mounting

⚠ Caution

3. Keep the flatness of the mounting surface within the following ranges when mounting the actuator body and workpiece.

Mounting the product on an uneven workpiece or base may result in an increase in the sliding resistance.

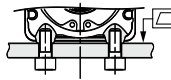
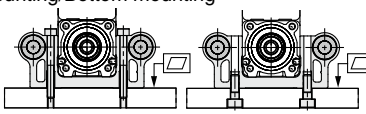
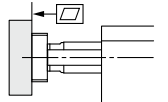
Model	Mounting position	Flatness
LEY□	Body/Body bottom 	0.1 mm or less
LEYG□	Top mounting/Bottom mounting 	0.02 mm or less
	Workpiece/Plate mounting 	0.02 mm or less

Maintenance

⚠ Warning

1. Ensure that the power supply is stopped and the workpiece is removed before starting maintenance work or replacing the product.

● Maintenance frequency

Perform maintenance according to the table below.

Frequency	Appearance check	Belt check
Inspection before daily operation	○	—
Inspection every 6 months/ 250 km/5 million cycles*1	○	○

*1 Select whichever comes first.

● Items for visual appearance check

1. Loose set screws, Abnormal amount of dirt, etc.
2. Check for visible damage, Check of cable joint
3. Vibration, Noise

● Items for belt check

Stop operation immediately and replace the belt when any of the following occur. In addition, ensure your operating environment and conditions satisfy the requirements specified for the product.

a. Tooth shape canvas is worn out

Canvas fiber becomes fuzzy, Rubber is coming off and the fiber has become whitish, Lines of fibers have become unclear

b. Peeling off or wearing of the side of the belt

Belt corner has become rounded and frayed threads sticks out

c. Belt partially cut

Belt is partially cut, Foreign matter caught in the teeth of other parts is causing damage

d. A vertical line on belt teeth is visible

Damage which is made when the belt runs on the flange

e. Rubber back of the belt is softened and sticky

f. Cracks on the back of the belt are visible

2. For IP65 equivalent type, apply grease on the piston rod periodically. Grease should be applied at 1 million cycles or 200 km, whichever comes first.

· Grease pack order number: GR-S-010 (10 g)/GR-S-020 (20 g)