



Air Gripper Unit for Collaborative Robots

MELFA ASSISTA Series
Mitsubishi Electric Corporation
collaborative robot compliant



JMHZ2-X7400B-ASSISTA



More information
can be viewed here.

P-E20-20

Air Gripper Unit for Collaborative Robots

Mitsubishi Electric Corporation collaborative robot

MELFA ASSISTA Series compliant



- Compact, lightweight product with high gripping force due to air operation
- An air gripper that realizes high rigidity and high precision due to its guide-integrated construction

With high-precision linear guide

Repeatability: ± 0.01 mm

Linear guide of the higher rigidity and precision is used.

Higher rigidity (Compared with the same size of the existing MHZ2)

- Operate by simply connecting 1 air supply tube and an electrical wiring M12 connector.
- Integrated solenoid valve, speed adjustment mechanism, and auto switch
- A split protective cover for easy air gripper maintenance
Allows you to maintain the air gripper without removing the user-specific attachment

Component Parts

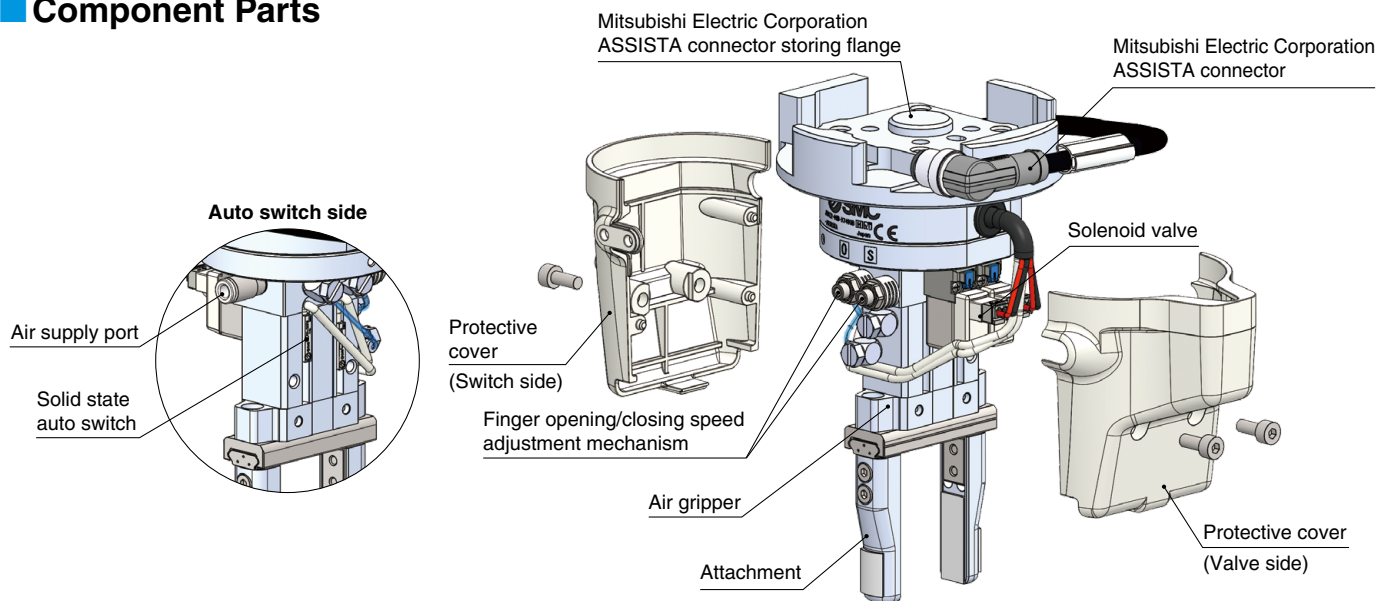

How to Order



JMHZ2-16D-X7400B-ASSISTA-**P**

Auto switch output type ●

Symbol	Auto switch model	Output type
Nil	D-M9N-5	NPN
P	D-M9P-5	PNP

Specifications

Bore size [mm]	16	
Fluid	Air	
Action	Double acting	
Operating pressure [MPa]	0.1 to 0.7	
Repeatability [mm]	± 0.01	
Number of fingers	2	
Gripping force Effective value per finger [N]	External	32.7
	Internal	43.5
Opening/Closing stroke (Both sides) [mm]	10	
Weight [g]	680	
Standards	ISO 9409-1-31.5-4-M5	
Connector type	M12 8-pin connector (Plug)	

■ Included parts: Coil tube for piping, fitting

Model Selection

Gripping force

● Indication of effective gripping force

The gripping force shown in the graphs below represents the gripping force of one finger when all fingers and attachments are in contact with the workpiece. **F** = One finger thrust

External gripping force

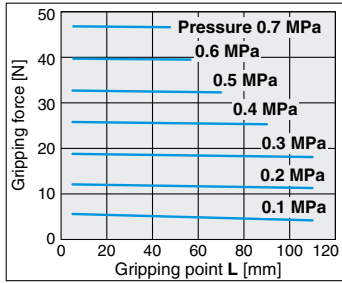
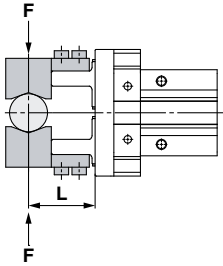

Internal gripping force

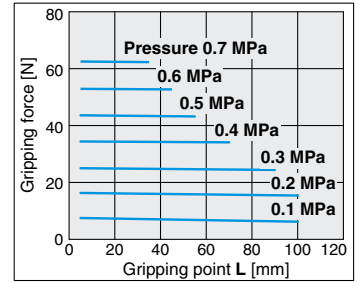
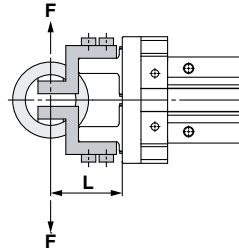

Gripping point

- The air gripper should be operated so that the workpiece gripping point "L" and the amount of overhang "H" stay within the range shown for each operating pressure given in the graphs below.
- If the workpiece gripping point goes beyond the range limits, this will have an adverse effect on the life of the air gripper.

External grip

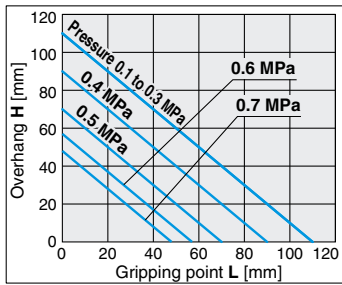
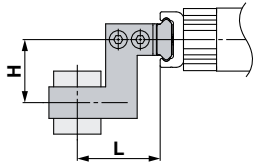

Internal grip

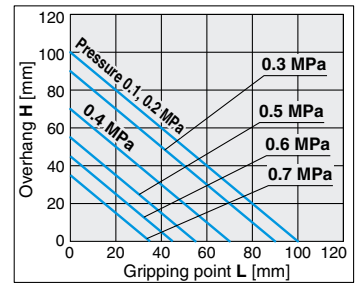
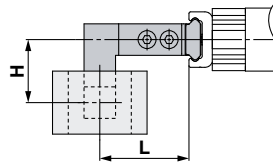

Dimensions

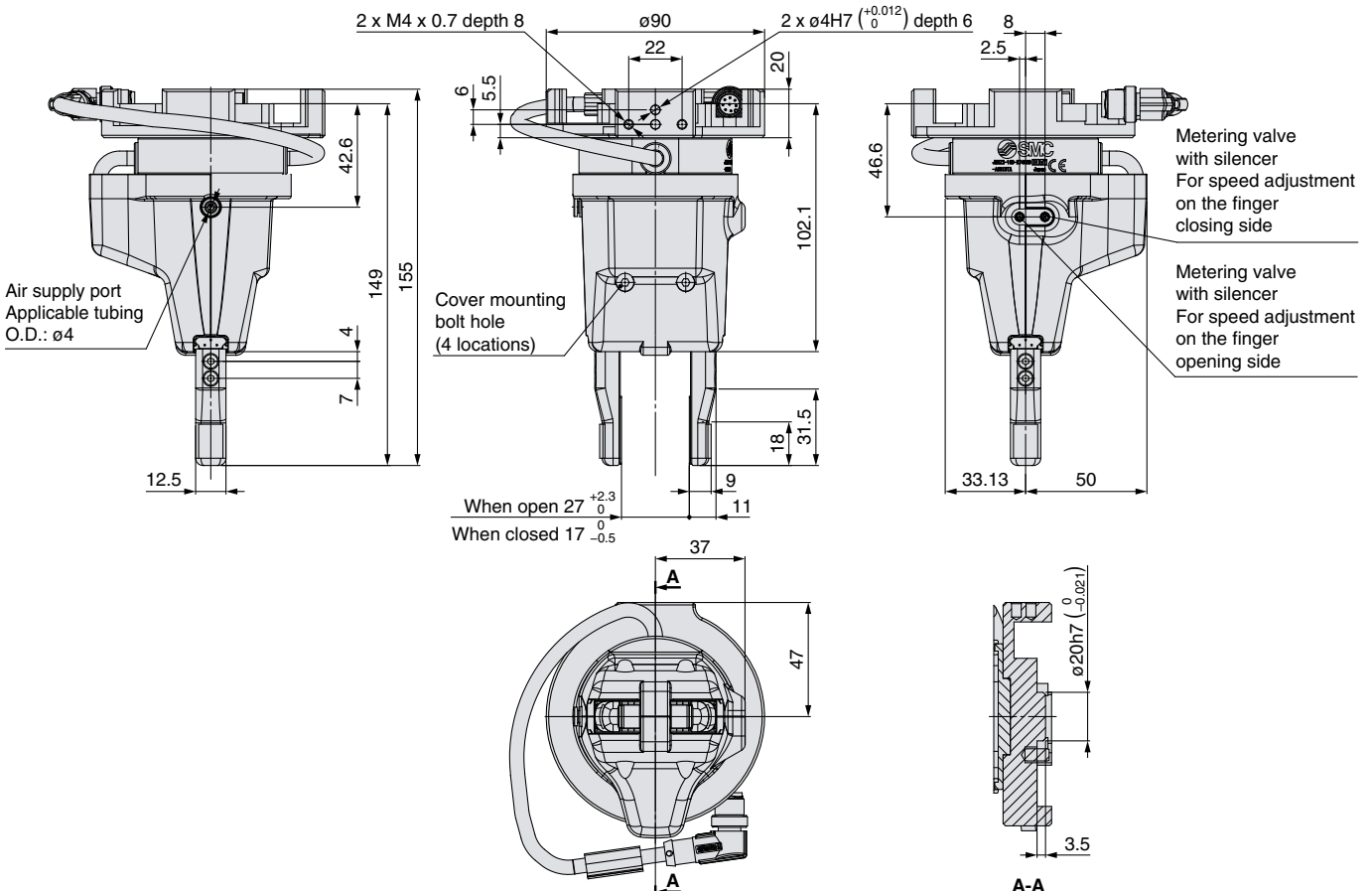



Air Gripper Unit for Collaborative Robots

MELFA
assist^a

 **Safety Instructions** Be sure to read the “Handling Precautions for SMC Products” (M-E03-3) and “Operation Manual” before use.