

High Performance

Electric Actuator



Cycle time can be reduced.

Cycle time

Reduced by **33%**
(0.62 s ← 0.93 s) compared with the existing model*1

*1 When LEFS25FH-400 is operated from 0 to 400 mm.

Acceleration/
Deceleration

9800 mm/s²
(327% increase compared with the existing model)

Max. speed

1500 mm/s
(Improved by 25% compared with the existing model)

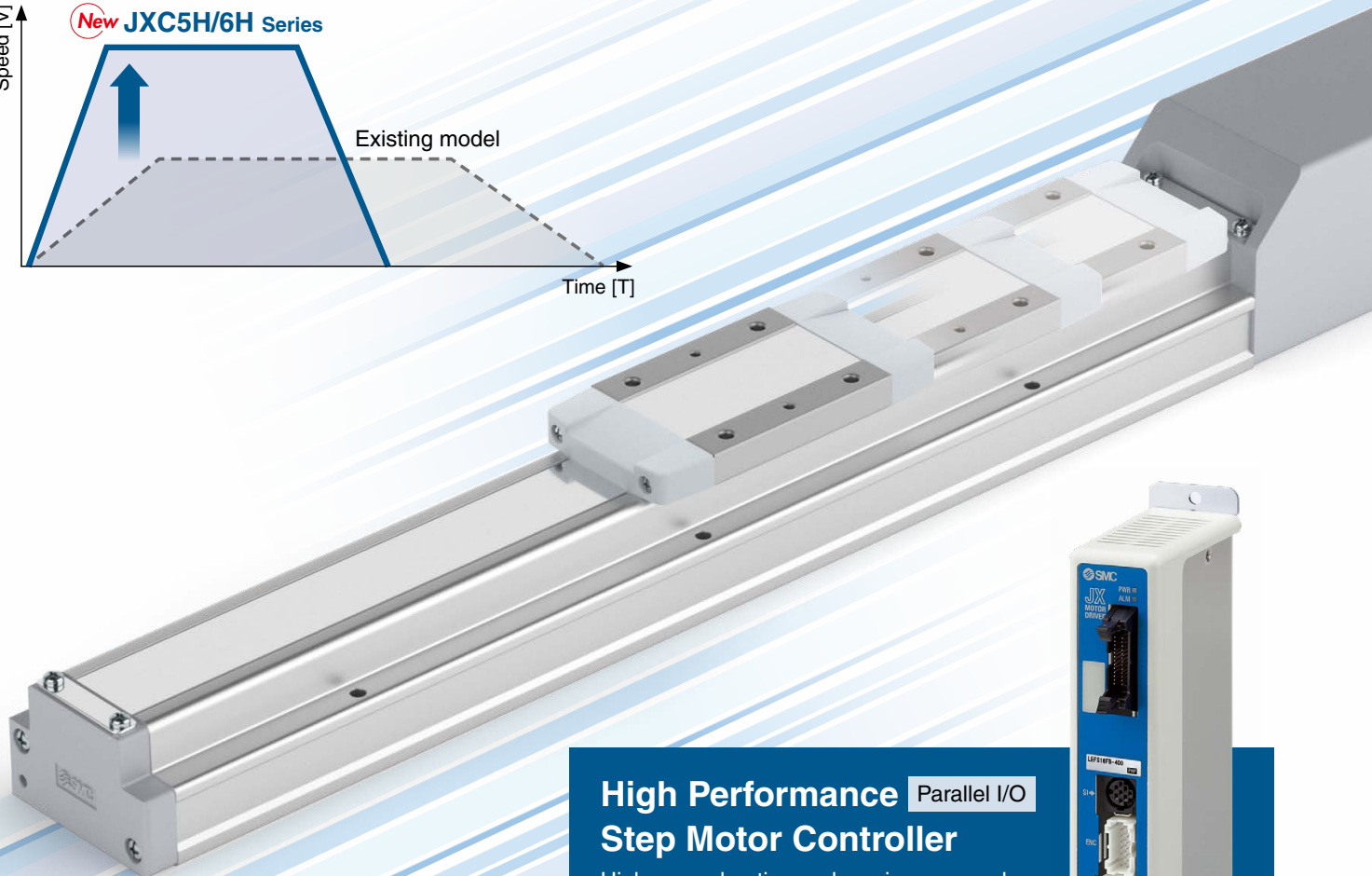
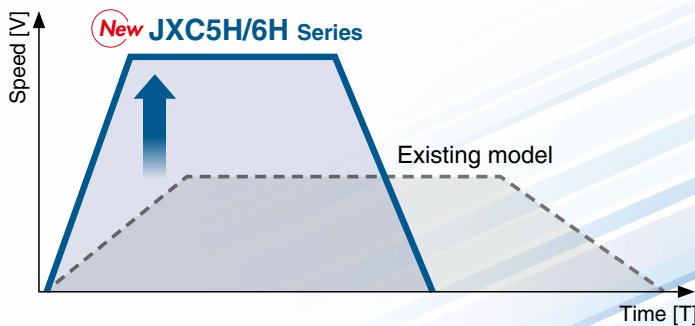

High Performance Parallel I/O
Step Motor Controller

Higher acceleration and maximum speed
can be set with the special controller
(for LEFS□F Series).

JXC5H/6H Series p. 24



LEFS□F Series



CAT.ES100-138A

Model Selection

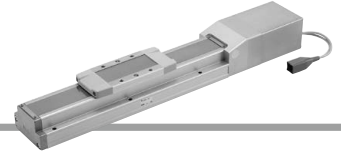

Selection Procedure



Selection Example

Operating conditions

- Workpiece mass: 10 [kg]
- Speed: 300 [mm/s]
- Acceleration/Deceleration: 9800 [mm/s²]
- Stroke: 200 [mm]
- Mounting orientation: Horizontal upward
- Workpiece mounting condition:

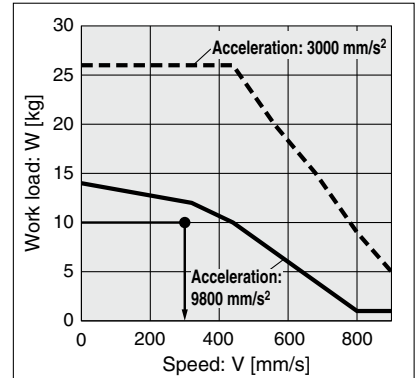
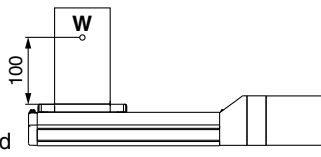

<Speed-Work load graph>
(LEFS25FA/Step motor)

Step 1 Check the work load-speed. <Speed-Work load graph> (pages 2 to 5)
Select a model based on the workpiece mass and speed while referencing the speed-work load graph.

Selection example) The **LEFS25FA-200** can be temporarily selected as a possible candidate based on the graph shown on the right side.

Step 2 Check the cycle time.

Calculate the **cycle time** using the following calculation method.

Cycle time:

T can be found from the following equation.

$$T = T1 + T2 + T3 + T4 \text{ [s]}$$

- T1: Acceleration time and T3: Deceleration time can be found by the following equation.

$$T1 = V/a1 \text{ [s]} \quad T3 = V/a2 \text{ [s]}$$

- T2: Constant speed time can be found from the following equation.

$$T2 = \frac{L - 0.5 \cdot V \cdot (T1 + T3)}{V} \text{ [s]}$$

- T4: Settling time varies depending on the conditions such as actuator types, load, and in position of the step data.

Reference value for settling time: 0.04 to 0.15 s
[Conditions: Horizontal transfer, In position 0.5 mm (Initial value)]

The following value is used for this calculation.

$$T4 = 0.04 \text{ [s]}$$

Calculation example)

T1 to T4 can be calculated as follows.

$$T1 = V/a1 = 300/9800 = 0.03 \text{ [s]}$$

$$T3 = V/a2 = 300/9800 = 0.03 \text{ [s]}$$

$$T2 = \frac{L - 0.5 \cdot V \cdot (T1 + T3)}{V} = \frac{200 - 0.5 \cdot 300 \cdot (0.03 + 0.03)}{300} = 0.64 \text{ [s]}$$

$$T4 = 0.04 \text{ [s]}$$

The **cycle time** can be found as follows.

$$T = T1 + T2 + T3 + T4 = 0.03 + 0.64 + 0.03 + 0.04 = 0.74 \text{ [s]}$$

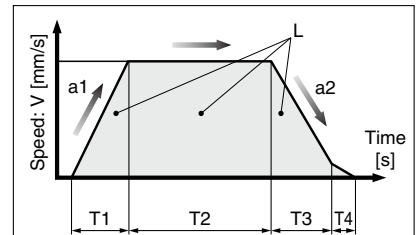

- L : Stroke [mm] ... (Operating condition)
- V : Speed [mm/s] ... (Operating condition)
- a1: Acceleration [mm/s²] ... (Operating condition)
- a2: Deceleration [mm/s²] ... (Operating condition)

- T1: Acceleration time [s]
Time until reaching the set speed
- T2: Constant speed time [s]
Time while the actuator is operating at a constant speed
- T3: Deceleration time [s]
Time from the beginning of the constant speed operation to stop
- T4: Settling time [s]
Time until positioning is completed

Step 3 Check the guide moment.

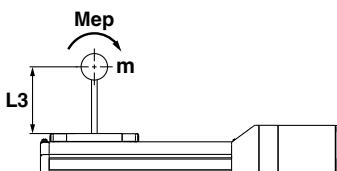

Based on the above calculation result, the **LEFS25FA-200** should be selected.

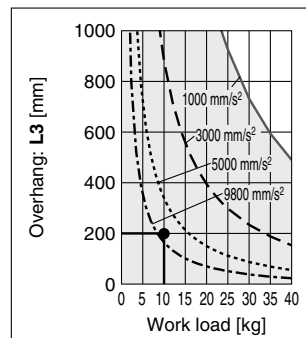

Speed-Work Load Graph (Guide)

* The following graphs show the values when moving force is 100%.

LEFS16FA/Ball Screw Drive

Horizontal/Lead 10

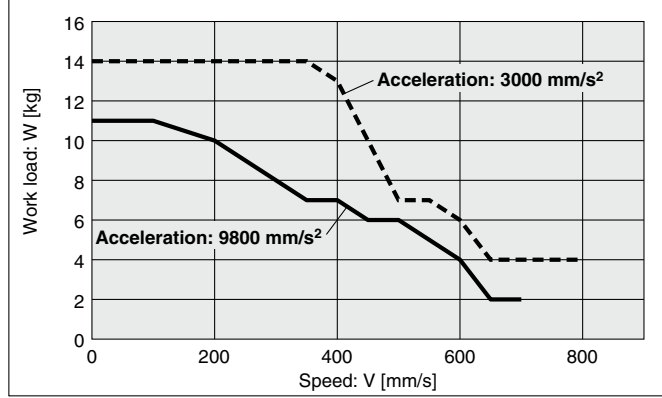

Vertical/Lead 10

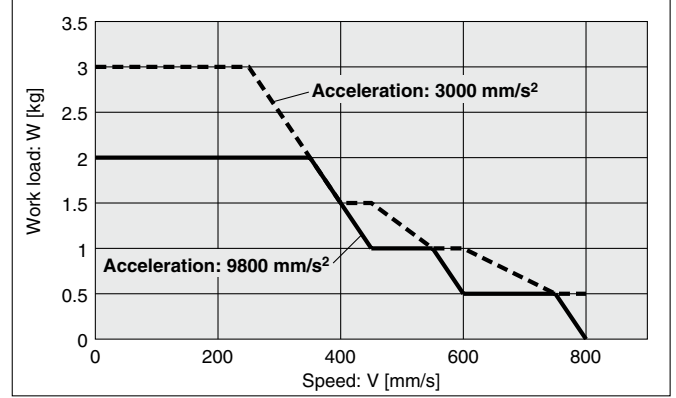

LEFS16FB/Ball Screw Drive

Horizontal/Lead 5

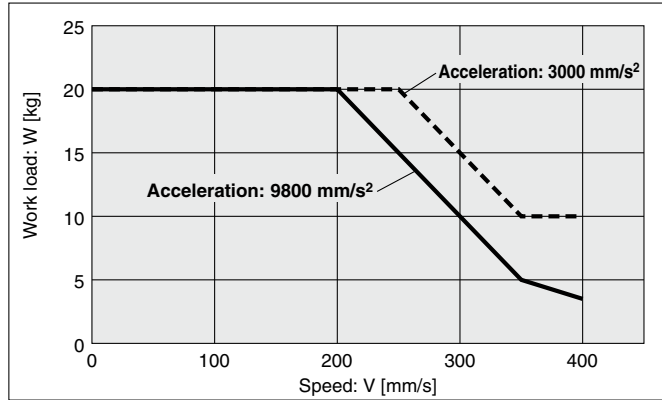

Vertical/Lead 5

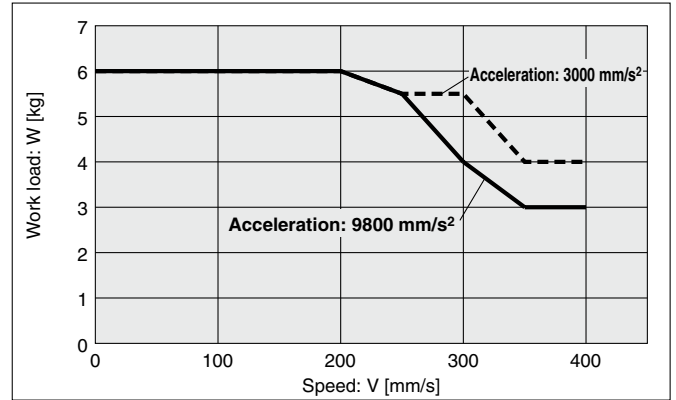

Model Selection
LEFS□F
Auto Switch
JXC5H/6H

Speed-Work Load Graph (Guide)

* The following graphs show the values when moving force is 100%.

LEFS25FH/Ball Screw Drive

Horizontal/Lead 20

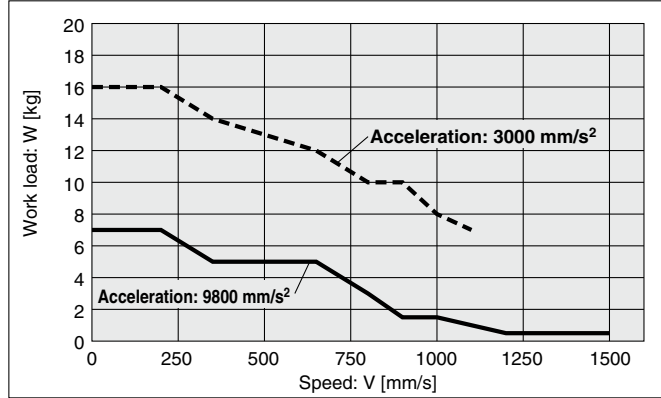

Vertical/Lead 20

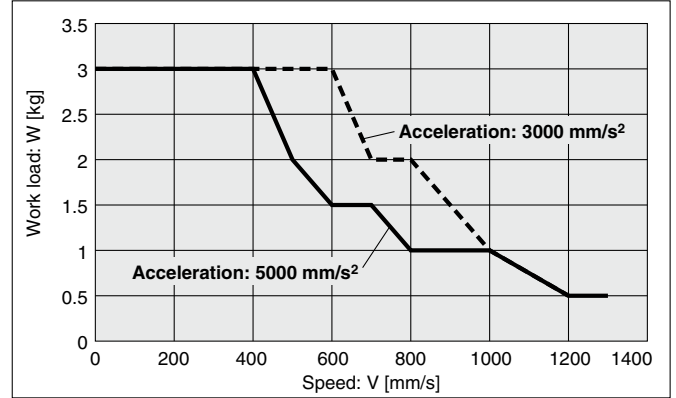

LEFS25FA/Ball Screw Drive

Horizontal/Lead 12

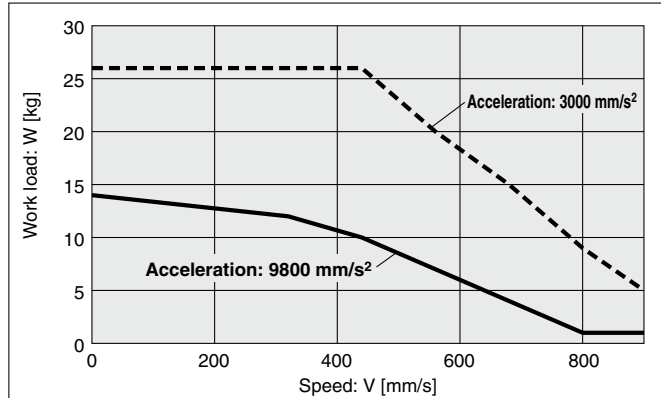

Vertical/Lead 12

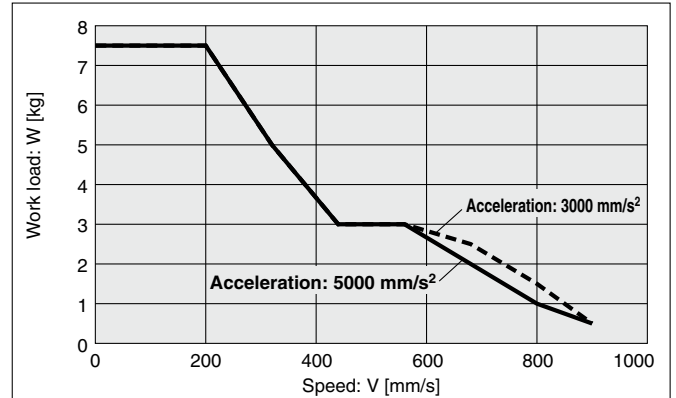

LEFS25FB/Ball Screw Drive

Horizontal/Lead 6

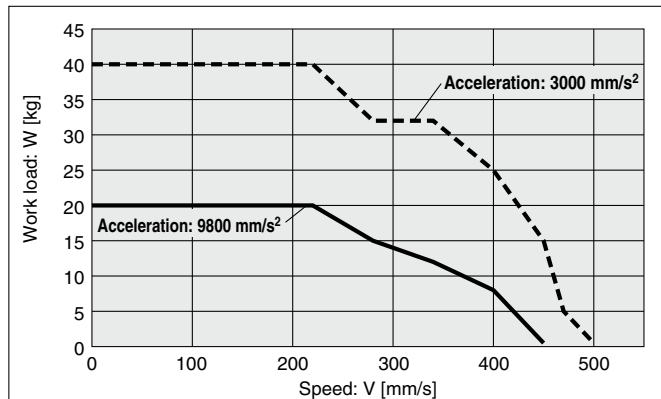

Vertical/Lead 6

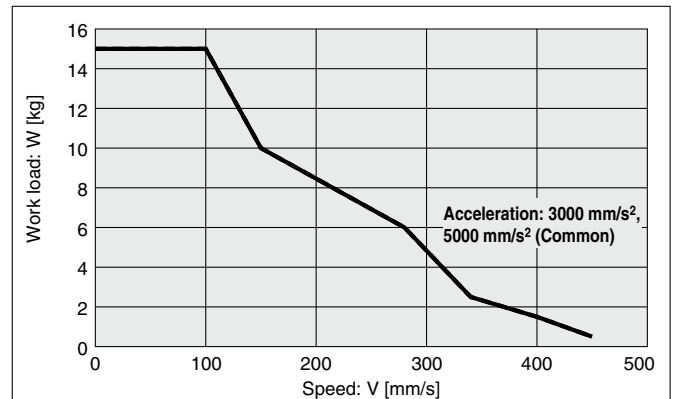

Speed-Work Load Graph (Guide)

* The following graphs show the values when moving force is 100%.

LEFS32FH/Ball Screw Drive

Horizontal/Lead 24

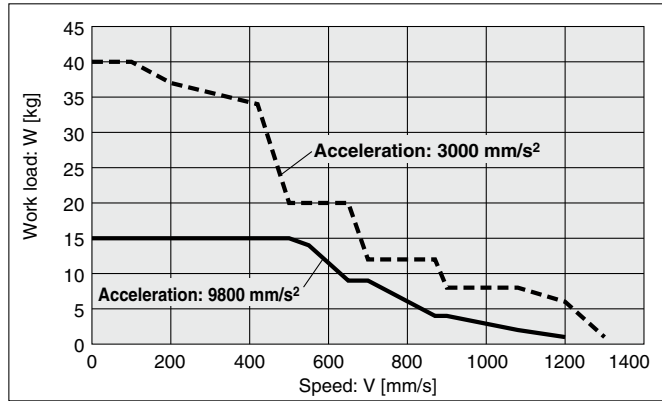

Vertical/Lead 24

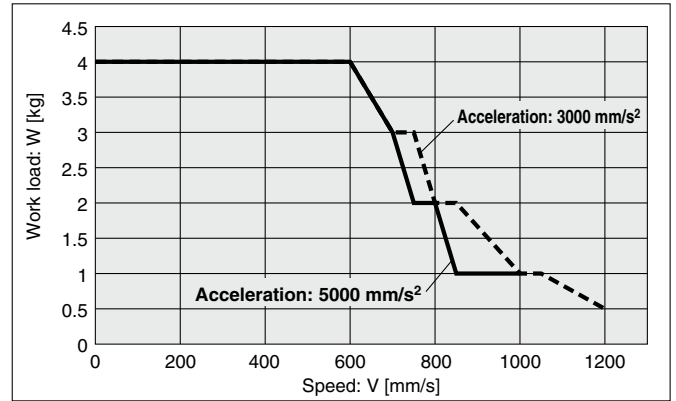

LEFS32FA/Ball Screw Drive

Horizontal/Lead 16

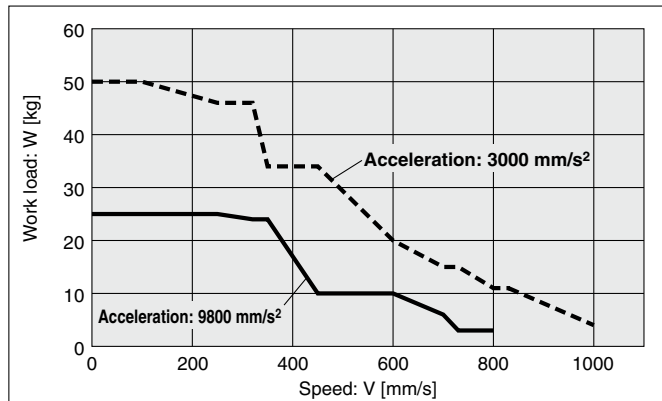

Vertical/Lead 16

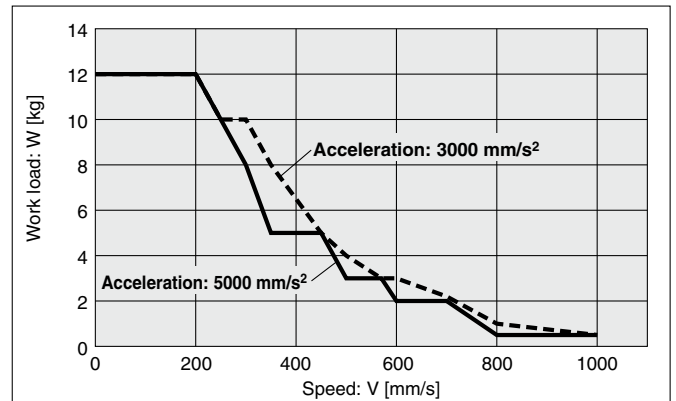

LEFS32FB/Ball Screw Drive

Horizontal/Lead 8

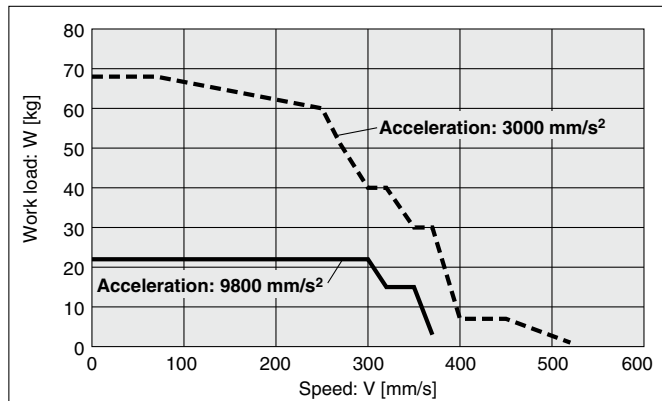

Vertical/Lead 8

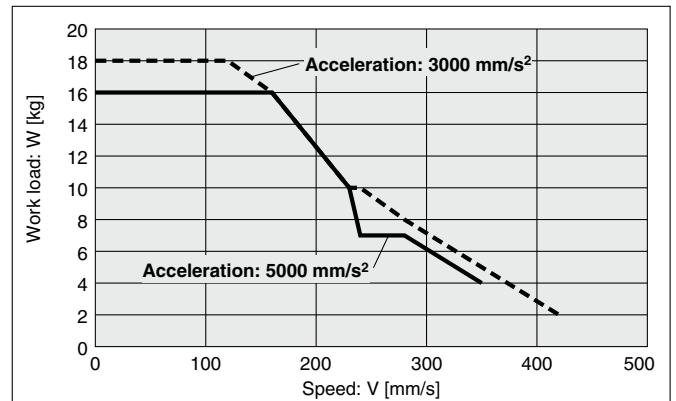

Model Selection
LEFS□F
Auto Switch
JXC5H/6H

Speed-Work Load Graph (Guide)

* The following graphs show the values when moving force is 100%.

LEFS40FH/Ball Screw Drive

Horizontal/Lead 30

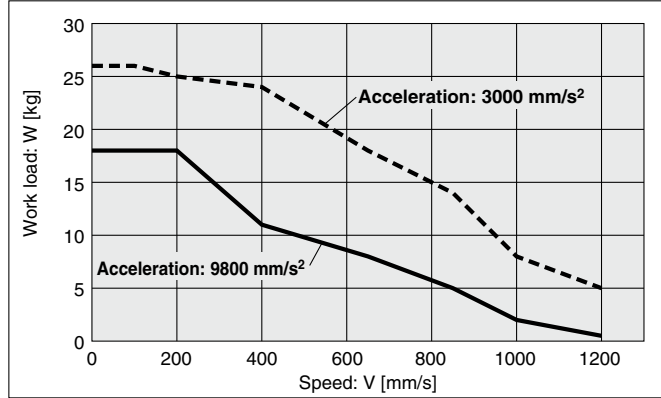

Vertical/Lead 30

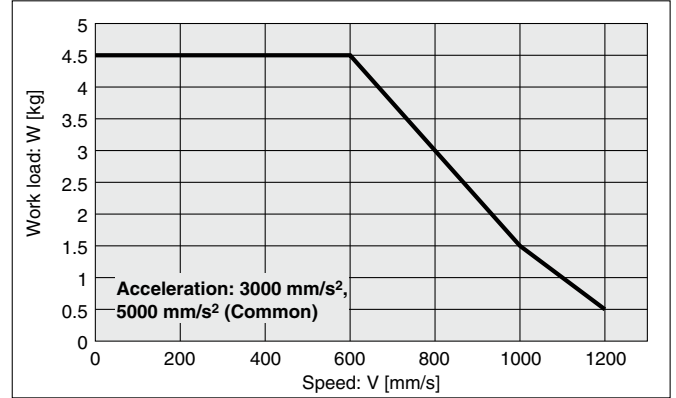

LEFS40FA/Ball Screw Drive

Horizontal/Lead 20

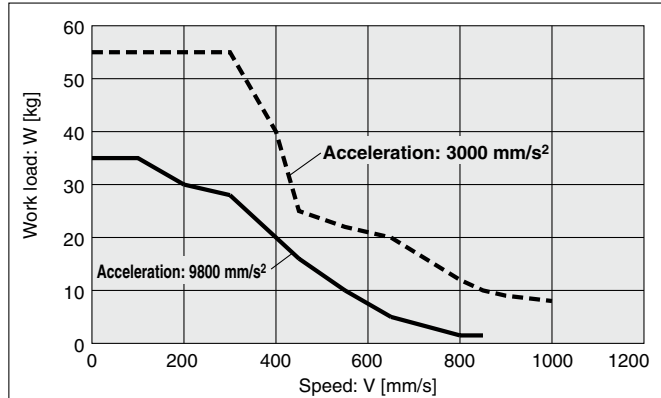

Vertical/Lead 20

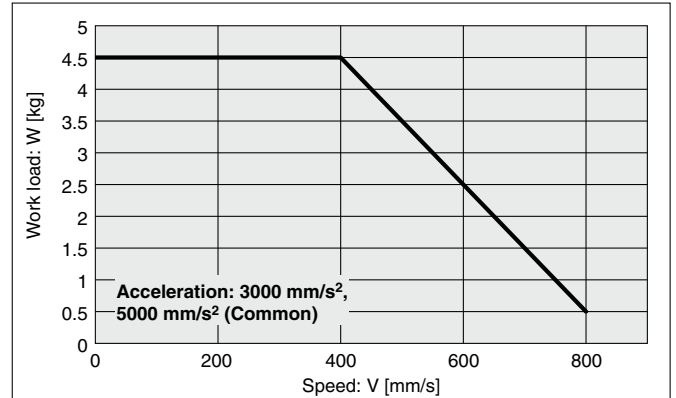

LEFS40FB/Ball Screw Drive

Horizontal/Lead 10

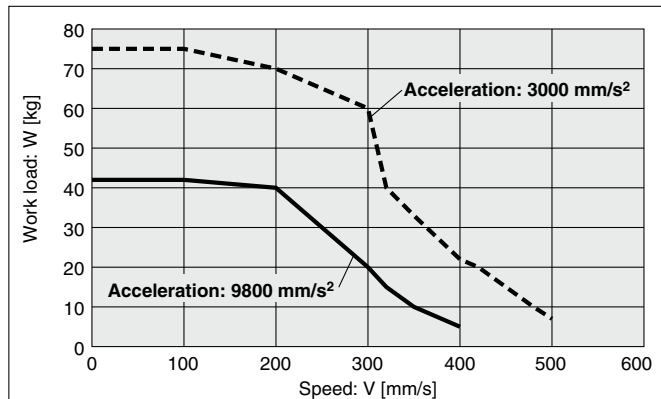

Vertical/Lead 10

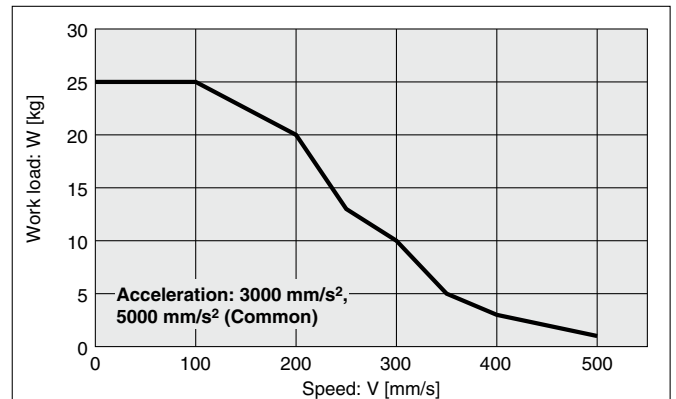

Dynamic Allowable Moment

* This graph shows the amount of allowable overhang (guide unit) when the center of gravity of the workpiece overhangs in one direction.

Acceleration ——— 1000 mm/s² - - - - 3000 mm/s² ······ 5000 mm/s² - - - - 9800 mm/s²

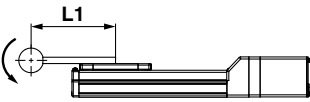
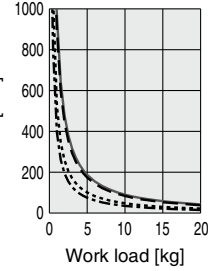
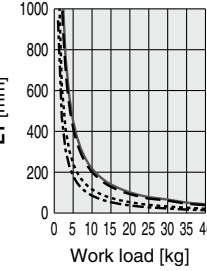
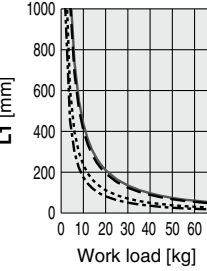
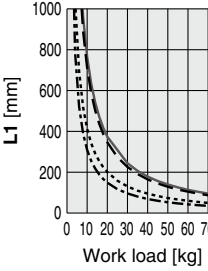
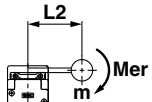
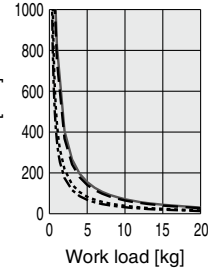
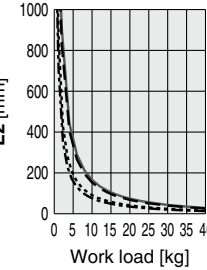
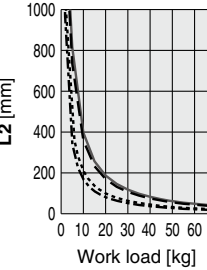
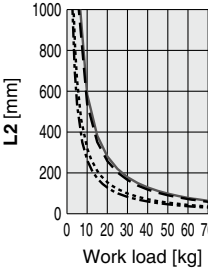
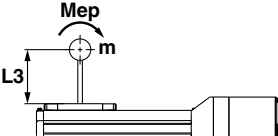
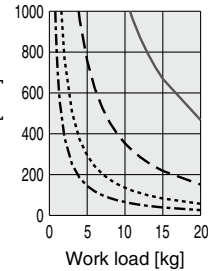
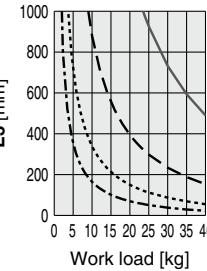
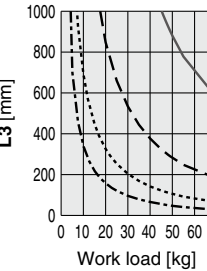
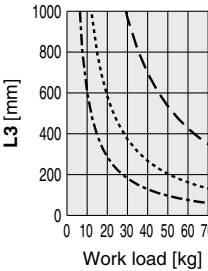
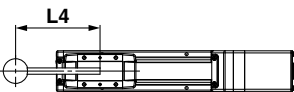
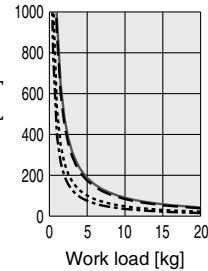
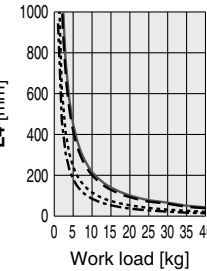
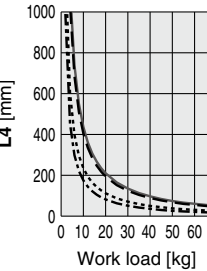
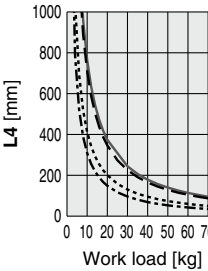
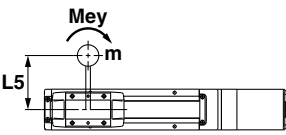
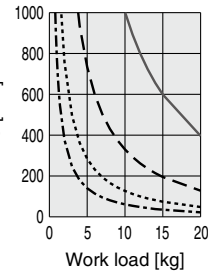
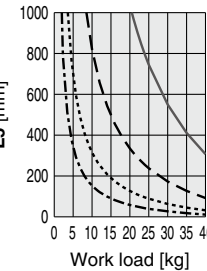
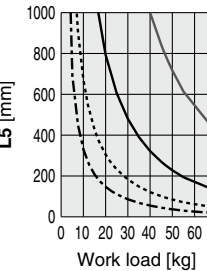
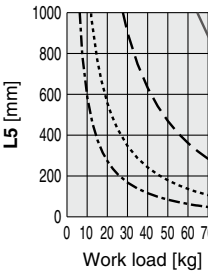
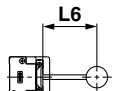
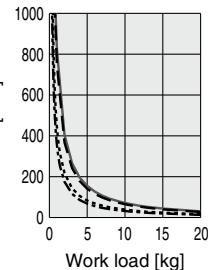
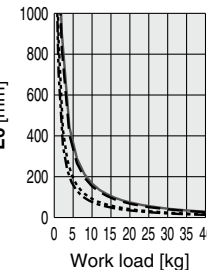
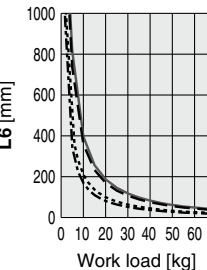
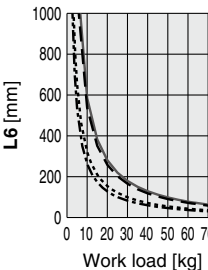
| Orientation | Load overhanging direction m : Work load [kg] Me: Dynamic allowable moment [N·m] L : Overhang to the work load center of gravity [mm] | Model | | | |
|-------------------|--|---|---|---|---|
| | | LEFS16F | LEFS25F | LEFS32F | LEFS40F |
| Horizontal/Bottom |  X |  |  |  |  |
| |  Y |  |  |  |  |
| |  Z |  |  |  |  |
| Wall |  X |  |  |  |  |
| |  Y |  |  |  |  |
| |  Z |  |  |  |  |

Model Selection
LEFS□F
Auto Switch
JXC5H/6H

Dynamic Allowable Moment

* This graph shows the amount of allowable overhang (guide unit) when the center of gravity of the workpiece overhangs in one direction.

Acceleration ——— 1000 mm/s² - - - 3000 mm/s² ······ 5000 mm/s²

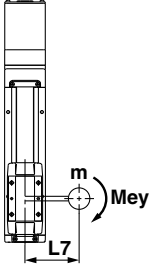
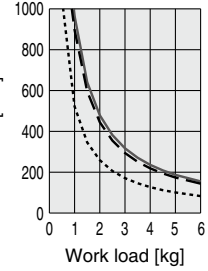
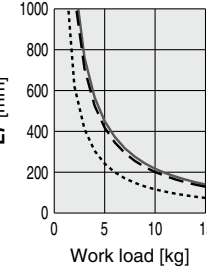
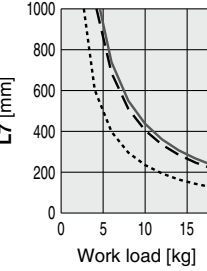
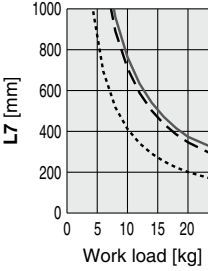
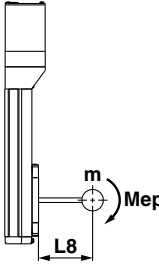
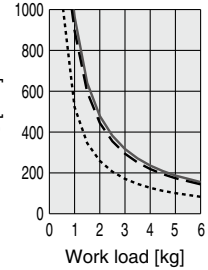
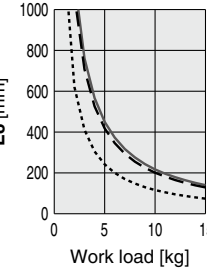
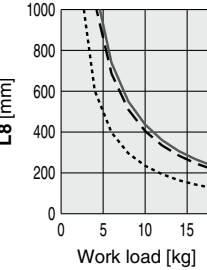
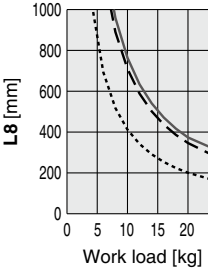
| Orientation | Load overhanging direction m : Work load [kg] Me: Dynamic allowable moment [N·m] L : Overhang to the work load center of gravity [mm] | Model | | | |
|-------------|--|--|--|--|--|
| | | LEFS16F | LEFS25F | LEFS32F | LEFS40F |
| Vertical | Y  |  |  |  |  |
| | Z  |  |  |  |  |

Calculation of Guide Load Factor

- Decide operating conditions.

Model: LEFS□F

Size: 25/32/40

Mounting orientation: Horizontal/Bottom/Wall/Vertical

Acceleration [mm/s²]: a

Work load [kg]: m

Work load center position [mm]: Xc/Yc/Zc

- Select the target graph while referencing the model, size, and mounting orientation.

- Based on the acceleration and work load, find the overhang [mm]: Lx/Ly/Lz from the graph.

- Calculate the load factor for each direction.

$$\alpha_x = X_c/L_x, \alpha_y = Y_c/L_y, \alpha_z = Z_c/L_z$$

- Confirm the total of α_x , α_y , and α_z is 1 or less.

$$\alpha_x + \alpha_y + \alpha_z \leq 1$$

When 1 is exceeded, please consider a reduction of acceleration and work load, or a change of the work load center position and series.

Mounting orientation

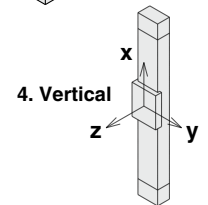
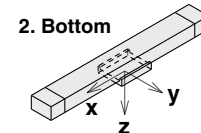
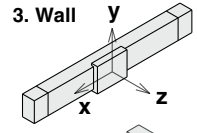
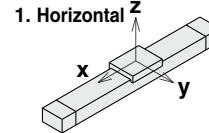

Example

- Operating conditions

Model: LEFS40F

Size: 40

Mounting orientation: Horizontal

Acceleration [mm/s²]: 3000

Work load [kg]: 20

Work load center position [mm]: Xc = 0, Yc = 50, Zc = 200

- Select the graphs for horizontal of the LEFS40F on page 6.

- Lx = 350 mm, Ly = 250 mm, Lz = 1000 mm

- The load factor for each direction can be found as follows.

$$\alpha_x = 0/350 = 0$$

$$\alpha_y = 50/250 = 0.2$$

$$\alpha_z = 200/1000 = 0.2$$

- $\alpha_x + \alpha_y + \alpha_z = 0.4 \leq 1$

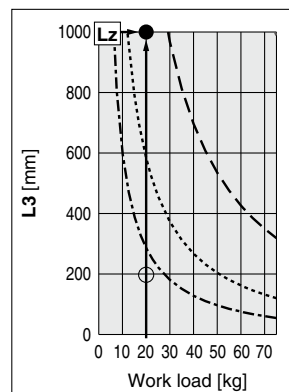
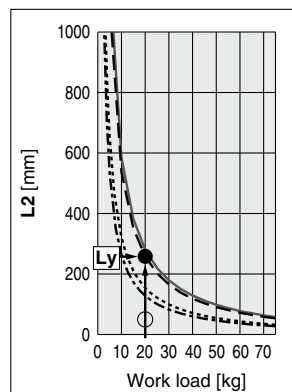
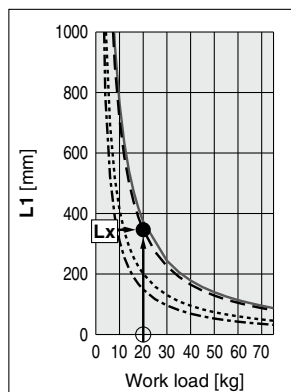
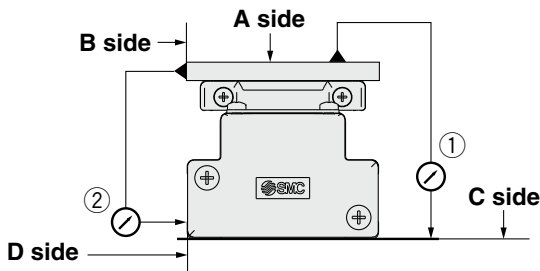

Table Accuracy (Reference Value)



| Model | Traveling parallelism [mm] (Every 300 mm) | |
|---------|---|--|
| | ① C side traveling parallelism to A side | ② D side traveling parallelism to B side |
| LEFS16F | 0.05 | 0.03 |
| LEFS25F | 0.05 | 0.03 |
| LEFS32F | 0.05 | 0.03 |
| LEFS40F | 0.05 | 0.03 |

* Traveling parallelism does not include the mounting surface accuracy. (Excludes when the stroke exceeds 2000 mm)

Table Displacement (Reference Value)

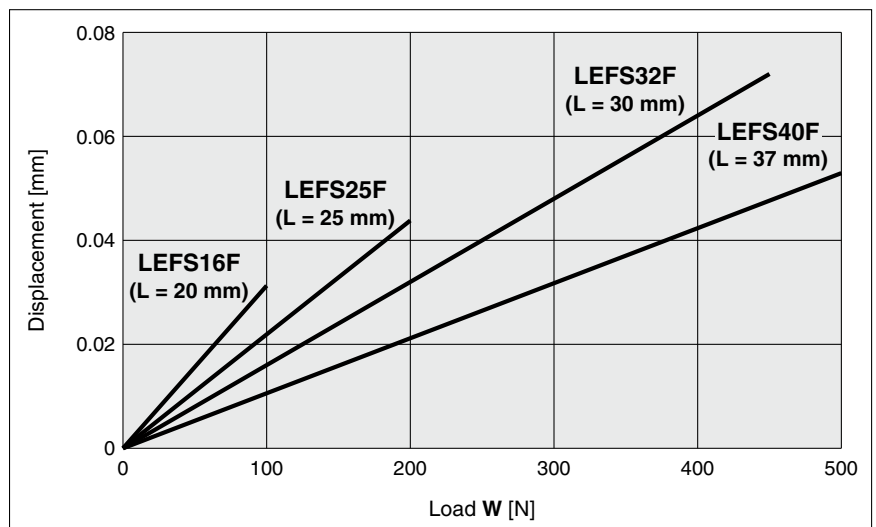
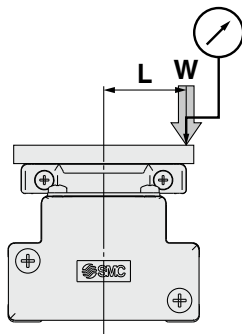

* This displacement is measured when a 15 mm aluminum plate is mounted and fixed on the table.
 * Check the clearance and play of the guide separately.

Overhang Displacement Due to Table Clearance (Initial Reference Value)

Basic type

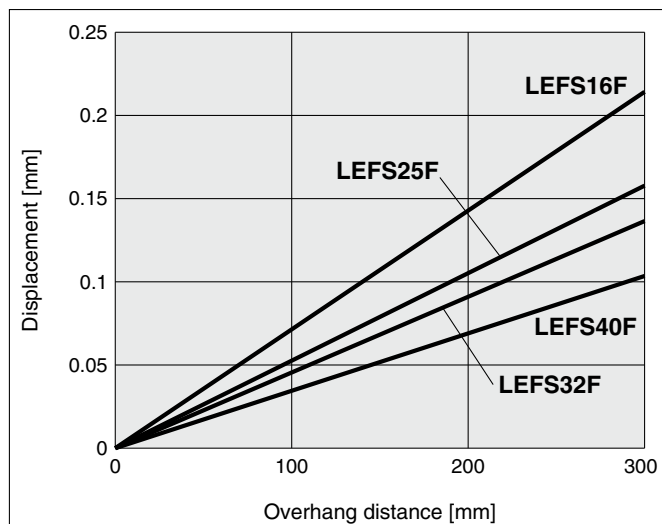

High-precision type

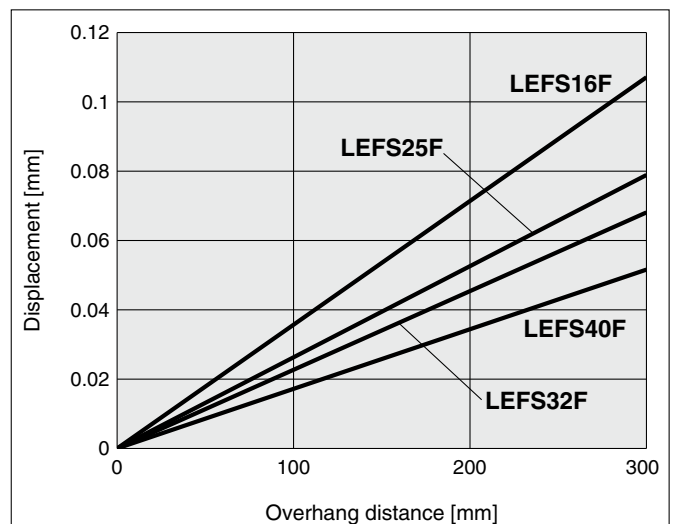

High Performance

Electric Actuator/Slider Type Ball Screw Drive

LEFS□F Series LEFS16, 25, 32, 40



How to Order

LEFS **H** **25** **F** **B** - **200** **C** **N** **K** - **S1** **C5H73**

①
②
③
④
⑤
⑥
⑦
⑧
⑨
⑩
⑪
⑫

For details on controllers, refer to page 24.

① Accuracy

| | |
|-----|---------------------|
| Nil | Basic type |
| H | High-precision type |

② Size

| |
|----|
| 16 |
| 25 |
| 32 |
| 40 |

④ Motor type

| Symbol | Type | Applicable size | | | | Compatible controllers |
|--------|--------------------------------------|-----------------|--------|--------|--------|------------------------|
| | | LEFS16 | LEFS25 | LEFS32 | LEFS40 | |
| F | High performance (Step motor 24 VDC) | ● | ● | ● | ● | JXC5H JXC6H |

③ Motor mounting position

| | |
|-----|---------|
| Nil | In-line |
|-----|---------|

⑤ Lead [mm]

| Symbol | LEFS16 | LEFS25 | LEFS32 | LEFS40 |
|--------|--------|--------|--------|--------|
| H | — | 20 | 24 | 30 |
| A | 10 | 12 | 16 | 20 |
| B | 5 | 6 | 8 | 10 |

⑥ Stroke*1 [mm]

| Stroke | Note | |
|-------------|------|---|
| | Size | Applicable stroke |
| 50 to 500 | 16 | 50, 100, 150, 200, 250, 300, 350, 400, 450, 500 |
| 50 to 800 | 25 | 50, 100, 150, 200, 250, 300, 350, 400, 450, 500, 550, 600, 650, 700, 750, 800 |
| 50 to 1000 | 32 | 50, 100, 150, 200, 250, 300, 350, 400, 450, 500, 550, 600, 650, 700, 750, 800, 850, 900, 950, 1000 |
| 150 to 1200 | 40 | 150, 200, 250, 300, 350, 400, 450, 500, 550, 600, 650, 700, 750, 800, 850, 900, 950, 1000, 1100, 1200 |

⑦ Motor option

| | |
|-----|----------------|
| Nil | Without option |
| B | With lock |

⑧ Auto switch compatibility*2 *3 *4 *5

| | |
|-----|------------------------------------|
| Nil | None |
| C | With (Includes 1 mounting bracket) |

⑨ Grease application (Seal band part)

| | |
|-----|--------------------------------|
| Nil | With |
| N | Without (Roller specification) |

⑩ Positioning pin hole

| | | |
|-----|-------------------------|--|
| Nil | Housing B bottom*6 | |
| K | Body bottom 2 locations | |

⑪ Actuator cable type/length*8

| Standard cable [m] | | Robotic cable [m] | | | |
|--------------------|------|-------------------|-----|----|------|
| Nil | None | R1 | 1.5 | RA | 10*7 |
| S1 | 1.5 | R3 | 3 | RB | 15*7 |
| S3 | 3 | R5 | 5 | RC | 20*7 |
| S5 | 5 | R8 | 8*7 | | |

For auto switches, refer to pages 20 to 23.

12 Controller

| | |
|-------|--------------------|
| Nil | Without controller |
| C□H□□ | With controller |



Controller type

| | |
|---|-------------------------|
| 5 | Parallel I/O (NPN) type |
| 6 | Parallel I/O (PNP) type |

Mounting

| | |
|-----|----------------|
| 7 | Screw mounting |
| 8*9 | DIN rail |

I/O cable length

| | |
|-----|---------------|
| Nil | Without cable |
| 1 | 1.5 m |
| 3 | 3 m |
| 5 | 5 m |

Number of axes/Special specification

| | |
|---|------------------------------|
| H | 1 axis/High performance type |
|---|------------------------------|

- *1 Please consult with SMC for non-standard strokes as they are produced as special orders.
- *2 Excluding the LEFS16
- *3 If 2 or more are required, please order them separately. (Part no.: LEF-D-2-1 For details, refer to the **Web Catalog**.)
- *4 The auto switches must be ordered separately. (For details, refer to the **Web Catalog**.)

- *5 When "Nil" is selected, the product will not come with a built-in magnet for an auto switch, and so a mounting bracket cannot be secured. Be sure to select an appropriate model initially as the product cannot be changed to have auto switch compatibility after purchase.
- *6 For details on the mounting method, refer to the **Web Catalog**.
- *7 Produced upon receipt of order (Robotic cable only)
- *8 The standard cable should only be used on fixed parts. For use on moving parts, select the robotic cable.
- *9 The DIN rail is not included. It must be ordered separately.

⚠ Caution

[CE-compliant products]

EMC compliance was tested by combining the electric actuator LEF series and the controller JXC series.

The EMC depends on the configuration of the customer's control panel and the relationship with other electrical equipment and wiring. Therefore, compliance with the EMC directive cannot be certified for SMC components incorporated into the customer's equipment under actual operating conditions. As a result, it is necessary for the customer to verify compliance with the EMC directive for the machinery and equipment as a whole.

[UL-compliant products]

The product with the controller which product number contains C□H□□ is UL approved. See 12 Controller above.

The actuator and controller are sold as a package.

Confirm that the combination of the controller and actuator is correct.

<Check the following before use.>

- *1 Check the actuator label for the model number. This number should match that of the controller.

LEFS25FA-400

*1



* Refer to the Operation Manual for using the products. Please download it via our website: <https://www.smcworld.com>

| | |
|---------------------------------|--|
| Type | Step data input type  |
| Series | JXC5H JXC6H |
| Features | Parallel I/O |
| Compatible motor | Step motor 24 VDC |
| Max. number of step data | 64 points |
| Power supply voltage | 24 VDC |
| Reference page | 24 |

Model Selection
LEFS□F
Auto Switch
JXC5H/6H

Specifications

| Model | | LEFS16F | | LEFS25F | | | LEFS32F | | | LEFS40F | | | | |
|---|--|--|------------------------|-----------|----------|------------|------------|----------|------------|-------------|-----------|------------|------------|-----------|
| Actuator specifications | Stroke [mm]* ¹ | 50 to 500 | | 50 to 800 | | | 50 to 1000 | | | 150 to 1200 | | | | |
| | Work load [kg]* ² | Horizontal | | 14 | 20 | 16 | 28* | 40 | 40 | 50 | 68 | 26 | 60* | 75 |
| | | Vertical | | 3 | 6 | 3 | 7.5 | 15 | 4 | 12 | 18 | 4.5 | 4.5 | 25 |
| | Speed [mm/s] | Stroke range | Up to 400 | 10 to 800 | 5 to 400 | 20 to 1500 | 12 to 900 | 6 to 500 | 24 to 1300 | 16 to 1000 | 8 to 520 | 30 to 1200 | 20 to 1000 | 10 to 500 |
| | | | 401 to 500 | 10 to 700 | 5 to 360 | 20 to 1100 | 12 to 750 | 6 to 400 | 24 to 1300 | 16 to 950 | 8 to 520 | 30 to 1200 | 20 to 1000 | 10 to 500 |
| | | | 501 to 600 | — | — | 20 to 900 | 12 to 540 | 6 to 270 | 24 to 1200 | 16 to 800 | 8 to 400 | 30 to 1200 | 20 to 1000 | 10 to 500 |
| | | | 601 to 700 | — | — | 20 to 630 | 12 to 420 | 6 to 230 | 24 to 930 | 16 to 620 | 8 to 310 | 30 to 1200 | 20 to 900 | 10 to 440 |
| | | | 701 to 800 | — | — | 20 to 550 | 12 to 330 | 6 to 180 | 24 to 750 | 16 to 500 | 8 to 250 | 30 to 1140 | 20 to 760 | 10 to 350 |
| | | | 801 to 900 | — | — | — | — | — | 24 to 610 | 16 to 410 | 8 to 200 | 30 to 930 | 20 to 620 | 10 to 280 |
| | | | 901 to 1000 | — | — | — | — | — | 24 to 500 | 16 to 340 | 8 to 170 | 30 to 780 | 20 to 520 | 10 to 250 |
| | | | 1001 to 1100 | — | — | — | — | — | — | — | — | 30 to 660 | 20 to 440 | 10 to 220 |
| | 1101 to 1200 | — | — | — | — | — | — | — | — | 30 to 570 | 20 to 380 | 10 to 190 | | |
| | Max. acceleration/deceleration [mm/s ²] | Horizontal | 9800 | | | | | | | | | | | |
| | | Vertical | 5000 | | | | | | | | | | | |
| | Positioning repeatability [mm] | Basic type | ±0.02 | | | | | | | | | | | |
| | | High-precision type | ±0.015 (Lead H: ±0.02) | | | | | | | | | | | |
| | Lost motion [mm]* ³ | Basic type | 0.1 or less | | | | | | | | | | | |
| High-precision type | | 0.05 or less | | | | | | | | | | | | |
| Lead [mm] | 10 | 5 | 20 | 12 | 6 | 24 | 16 | 8 | 30 | 20 | 10 | | | |
| Impact/Vibration resistance [m/s ²]* ⁴ | 50/20 | | | | | | | | | | | | | |
| Actuation type | Ball screw | | | | | | | | | | | | | |
| Guide type | Linear guide | | | | | | | | | | | | | |
| Operating temperature range [°C] | 5 to 40 | | | | | | | | | | | | | |
| Operating humidity range [%RH] | 90 or less (No condensation) | | | | | | | | | | | | | |
| Electric specifications | Motor size | □28 | | □42 | | | □56.4 | | | □56.4 | | | | |
| | Motor type | Step motor (Servo/24 VDC) | | | | | | | | | | | | |
| | Encoder | Incremental A/B phase (800 pulse/rotation) | | | | | | | | | | | | |
| | Rated voltage [V] | 24 VDC ±10% | | | | | | | | | | | | |
| | Standby power consumption when operating [W]* ⁵ | 27 | | 16 | | | 44 | | | 43 | | | | |
| | Max. power consumption [W]* ⁶ | 102 | | 132 | | | 158 | | | 202 | | | | |
| Lock unit specifications | Type* ⁷ | Non-magnetizing lock | | | | | | | | | | | | |
| | Holding force [N] | 20 | 39 | 47 | 78 | 157 | 72 | 108 | 216 | 75 | 113 | 225 | | |
| | Power consumption [W]* ⁸ | 2.9 | | 5 | | | 5 | | | 5 | | | | |
| | Rated voltage [V] | 24 VDC ±10% | | | | | | | | | | | | |

*1 Please consult with SMC for non-standard strokes as they are produced as special orders.

*2 The maximum work load at 3000 mm/s² acceleration and deceleration speed. (Values with * show the maximum work load at 1000 mm/s² acceleration and deceleration speed). Work load varies depending on the speed and acceleration. Check the "Speed-Work Load Graph" on pages 2 to 5. Furthermore, if the cable length exceeds 5 m, the speed and work load specified in the "Speed-Work Load Graph" may decrease by up to 10% for each 5 m increase.

*3 A reference value for correcting an error in reciprocal operation

*4 Impact resistance: No malfunction occurred when the actuator was tested with a drop tester in both an axial direction and a perpendicular direction to the lead screw. (The test was performed with the actuator in the initial state.)

Vibration resistance: No malfunction occurred in a test ranging between 45 to 2000 Hz. The test was performed in both an axial direction and a perpendicular direction to the lead screw. (The test was performed with the actuator in the initial state.)

*5 The standby power consumption when operating (including the controller) is for when the actuator is stopped in the set position during the operation.

*6 The maximum power consumption (including the controller) is for when the actuator is operating. This value can be used for the selection of the power supply. If the power supply capacity is not sufficient for the instantaneous power of the connected actuator, the expected performance at set acceleration and speed may not be realized depending on the operating conditions.

*7 With lock only

*8 For an actuator with lock, add the power consumption for the lock.

Weight

| Series | LEFS16F | | | | | | | | | |
|----------------------------------|---------|------|------|------|------|------|------|------|------|------|
| Stroke [mm] | 50 | 100 | 150 | 200 | 250 | 300 | 350 | 400 | 450 | 500 |
| Product weight [kg] | 0.85 | 0.92 | 1.00 | 1.07 | 1.15 | 1.22 | 1.30 | 1.37 | 1.45 | 1.52 |
| Additional weight with lock [kg] | 0.12 | | | | | | | | | |

| Series | LEFS25F | | | | | | | | | | | | | | | |
|----------------------------------|---------|------|------|------|------|------|------|------|------|------|------|------|------|------|------|------|
| Stroke [mm] | 50 | 100 | 150 | 200 | 250 | 300 | 350 | 400 | 450 | 500 | 550 | 600 | 650 | 700 | 750 | 800 |
| Product weight [kg] | 1.70 | 1.84 | 1.98 | 2.12 | 2.26 | 2.40 | 2.54 | 2.68 | 2.82 | 2.96 | 3.10 | 3.24 | 3.38 | 3.52 | 3.66 | 3.80 |
| Additional weight with lock [kg] | 0.26 | | | | | | | | | | | | | | | |

| Series | LEFS32F | | | | | | | | | | | | | | | | | | | |
|----------------------------------|---------|------|------|------|------|------|------|------|------|------|------|------|------|------|------|------|------|------|------|------|
| Stroke [mm] | 50 | 100 | 150 | 200 | 250 | 300 | 350 | 400 | 450 | 500 | 550 | 600 | 650 | 700 | 750 | 800 | 850 | 900 | 950 | 1000 |
| Product weight [kg] | 3.15 | 3.35 | 3.55 | 3.75 | 3.95 | 4.15 | 4.35 | 4.55 | 4.75 | 4.95 | 5.15 | 5.35 | 5.55 | 5.75 | 5.95 | 6.15 | 6.35 | 6.55 | 6.75 | 6.95 |
| Additional weight with lock [kg] | 0.53 | | | | | | | | | | | | | | | | | | | |

| Series | LEFS40F | | | | | | | | | | | | | | | | | | | |
|----------------------------------|---------|------|------|------|------|------|------|------|------|------|------|------|------|------|------|------|------|-------|-------|-------|
| Stroke [mm] | 150 | 200 | 250 | 300 | 350 | 400 | 450 | 500 | 550 | 600 | 650 | 700 | 750 | 800 | 850 | 900 | 950 | 1000 | 1100 | 1200 |
| Product weight [kg] | 5.37 | 5.65 | 5.93 | 6.21 | 6.49 | 6.77 | 7.15 | 7.33 | 7.61 | 7.89 | 8.17 | 8.45 | 8.73 | 9.01 | 9.29 | 9.57 | 9.85 | 10.13 | 10.69 | 11.25 |
| Additional weight with lock [kg] | 0.53 | | | | | | | | | | | | | | | | | | | |

Model Selection

LEFS□F

Auto Switch

JXC5H/6H

LEFS□F Series

Dimensions: In-line Motor

LEFS16F

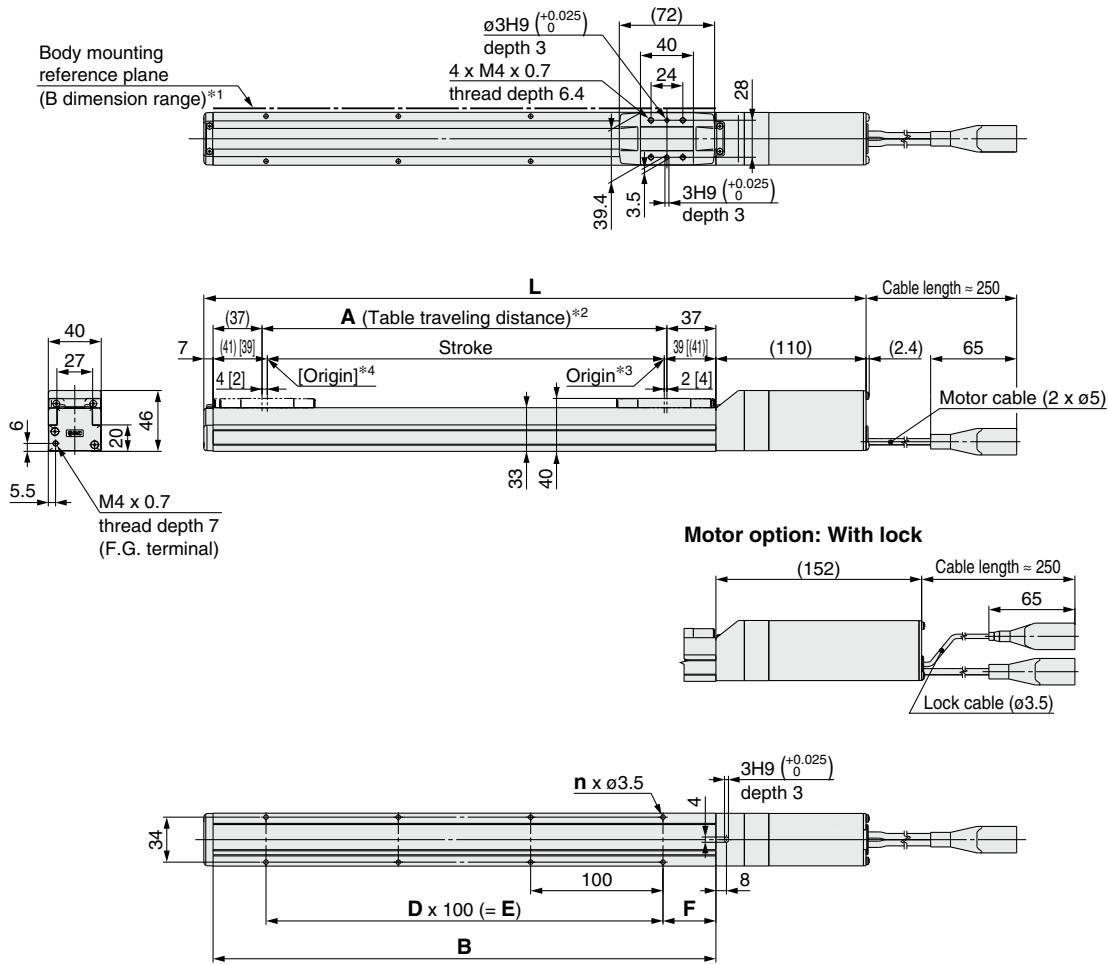

Positioning pin hole*5 (Option): Body bottom

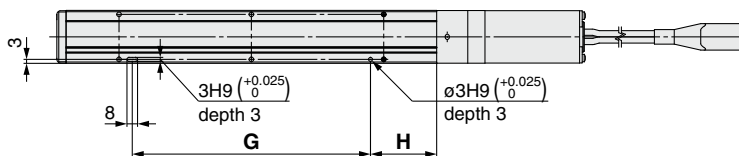

- *1 When mounting the actuator using the body mounting reference plane, set the height of the opposite surface or pin to be 2 mm or more because of round chamfering. (Recommended height 5 mm)
In addition, be aware that surfaces other than the body mounting reference plane (B dimension range) may slightly protrude from the body mounting reference plane. Be sure to provide a clearance of 1 mm or more to avoid interference with workpieces, facilities, etc.
- *2 This is the distance within which the table can move when it returns to origin.
Make sure workpieces mounted on the table do not interfere with the workpieces and facilities around the table.
- *3 Position after returning to origin
- *4 [] for when the direction of return to origin has changed
- *5 When using the body bottom positioning pin holes, do not simultaneously use the housing B bottom pin hole.

Dimensions

| Model | L | | A | B | n | D | E | F | G | H |
|---------------|--------------|-----------|-----|-----|----|---|-----|----|-----|----|
| | Without lock | With lock | | | | | | | | |
| LEFS16F□-50□ | 247 | 289 | 56 | 130 | 4 | — | — | 15 | 80 | 25 |
| LEFS16F□-100□ | 297 | 339 | 106 | 180 | 4 | — | — | 40 | 80 | 50 |
| LEFS16F□-150□ | 347 | 389 | 156 | 230 | 4 | — | — | | 80 | 50 |
| LEFS16F□-200□ | 397 | 439 | 206 | 280 | 6 | 2 | 200 | | 180 | 50 |
| LEFS16F□-250□ | 447 | 489 | 256 | 330 | 6 | 2 | 200 | | 180 | 50 |
| LEFS16F□-300□ | 497 | 539 | 306 | 380 | 8 | 3 | 300 | | 280 | 50 |
| LEFS16F□-350□ | 547 | 589 | 356 | 430 | 8 | 3 | 300 | | 280 | 50 |
| LEFS16F□-400□ | 597 | 639 | 406 | 480 | 10 | 4 | 400 | | 380 | 50 |
| LEFS16F□-450□ | 647 | 689 | 456 | 530 | 10 | 4 | 400 | | 380 | 50 |
| LEFS16F□-500□ | 697 | 739 | 506 | 580 | 12 | 5 | 500 | | 480 | 50 |

Dimensions: In-line Motor

LEFS25F

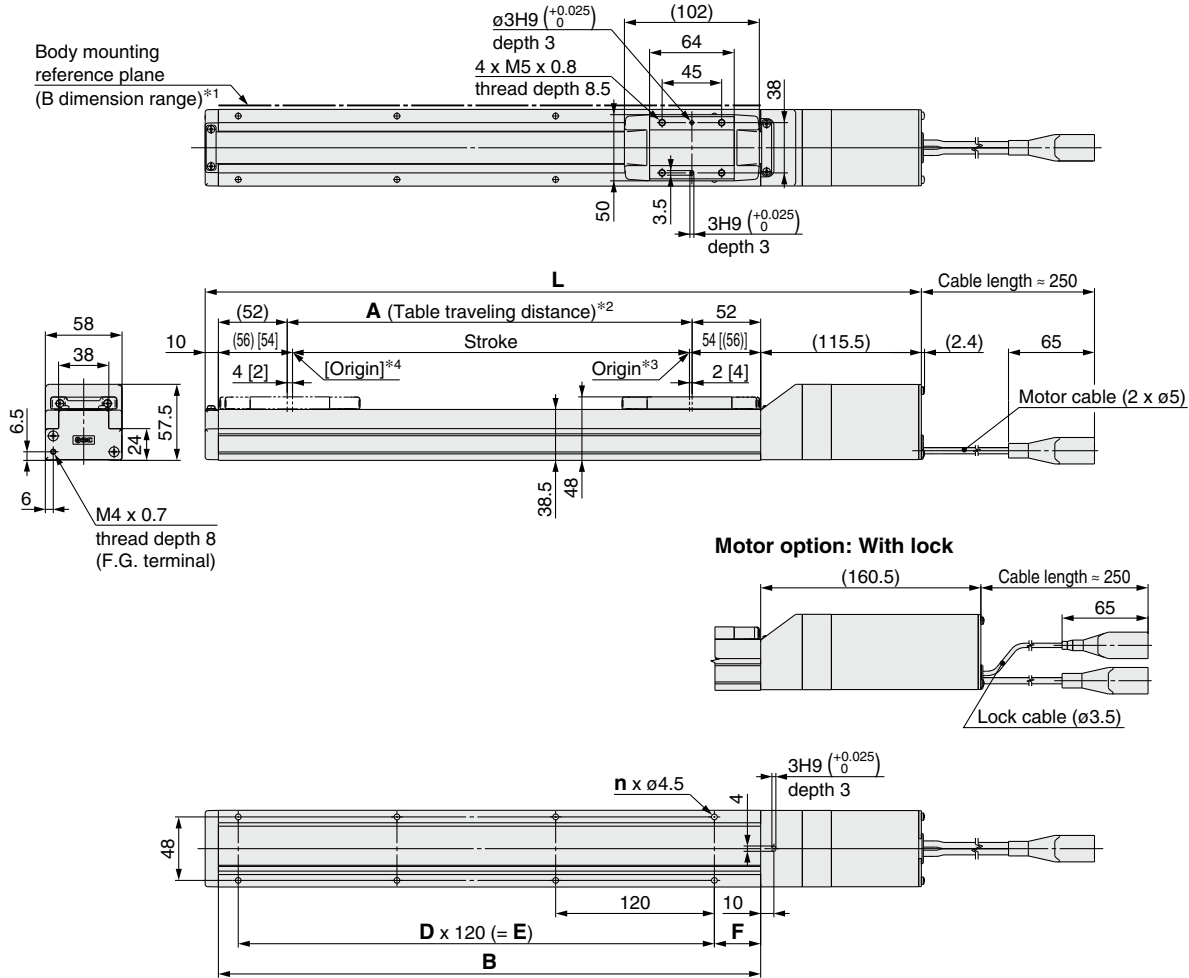

- *1 When mounting the actuator using the body mounting reference plane, set the height of the opposite surface or pin to be 3 mm or more because of round chamfering. (Recommended height 5 mm)
In addition, be aware that surfaces other than the body mounting reference plane (B dimension range) may slightly protrude from the body mounting reference plane. Be sure to provide a clearance of 1 mm or more to avoid interference with workpieces, facilities, etc.
- *2 This is the distance within which the table can move when it returns to origin.
Make sure workpieces mounted on the table do not interfere with the workpieces and facilities around the table.
- *3 Position after returning to origin
- *4 [] for when the direction of return to origin has changed

Dimensions

| Model | L | | A | B | n | D | E | F |
|---------------|--------------|-----------|-----|-----|----|---|-----|----|
| | Without lock | With lock | | | | | | |
| LEFS25F□-50□ | 285.5 | 330.5 | 56 | 160 | 4 | — | — | 20 |
| LEFS25F□-100□ | 335.5 | 380.5 | 106 | 210 | 4 | — | — | 35 |
| LEFS25F□-150□ | 385.5 | 430.5 | 156 | 260 | 4 | — | — | |
| LEFS25F□-200□ | 435.5 | 480.5 | 206 | 310 | 6 | 2 | 240 | |
| LEFS25F□-250□ | 485.5 | 530.5 | 256 | 360 | 6 | 2 | 240 | |
| LEFS25F□-300□ | 535.5 | 580.5 | 306 | 410 | 8 | 3 | 360 | |
| LEFS25F□-350□ | 585.5 | 630.5 | 356 | 460 | 8 | 3 | 360 | |
| LEFS25F□-400□ | 635.5 | 680.5 | 406 | 510 | 8 | 3 | 360 | |
| LEFS25F□-450□ | 685.5 | 730.5 | 456 | 560 | 10 | 4 | 480 | |
| LEFS25F□-500□ | 735.5 | 780.5 | 506 | 610 | 10 | 4 | 480 | |
| LEFS25F□-550□ | 785.5 | 830.5 | 556 | 660 | 12 | 5 | 600 | |
| LEFS25F□-600□ | 835.5 | 880.5 | 606 | 710 | 12 | 5 | 600 | |
| LEFS25F□-650□ | 885.5 | 930.5 | 656 | 760 | 12 | 5 | 600 | |
| LEFS25F□-700□ | 935.5 | 980.5 | 706 | 810 | 14 | 6 | 720 | |
| LEFS25F□-750□ | 985.5 | 1030.5 | 756 | 860 | 14 | 6 | 720 | |
| LEFS25F□-800□ | 1035.5 | 1080.5 | 806 | 910 | 16 | 7 | 840 | |

Model Selection
LEFS□F
Auto Switch
JXC5H/6H

LEFS□F Series

Dimensions: In-line Motor

LEFS25F

Positioning pin hole*1 (Option): Body bottom

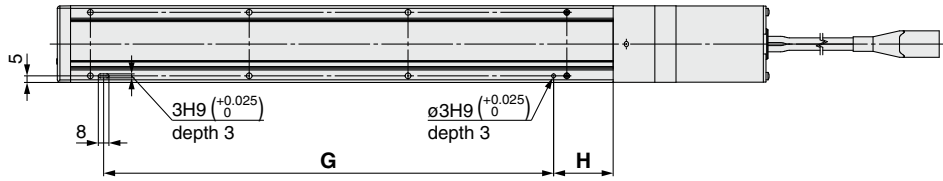

*1 When using the body bottom positioning pin holes, do not simultaneously use the housing B bottom pin hole.

With auto switch (Option)

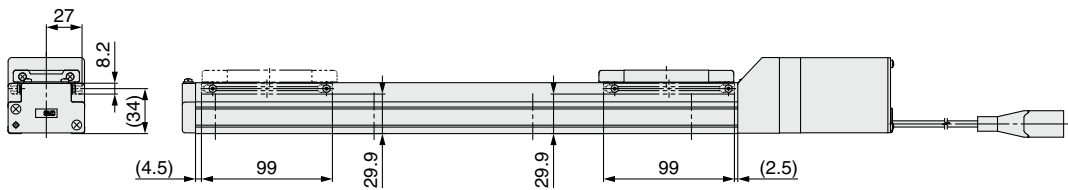

* For strokes of 99 mm or less, only 2 auto switch mounting brackets can be installed on the motor side.

Dimensions [mm]

| Model | G | H |
|---------------|-----|----|
| LEFS25F□-50□ | 100 | 30 |
| LEFS25F□-100□ | 100 | 45 |
| LEFS25F□-150□ | 100 | 45 |
| LEFS25F□-200□ | 220 | 45 |
| LEFS25F□-250□ | 220 | 45 |
| LEFS25F□-300□ | 340 | 45 |
| LEFS25F□-350□ | 340 | 45 |
| LEFS25F□-400□ | 340 | 45 |
| LEFS25F□-450□ | 460 | 45 |
| LEFS25F□-500□ | 460 | 45 |
| LEFS25F□-550□ | 580 | 45 |
| LEFS25F□-600□ | 580 | 45 |
| LEFS25F□-650□ | 580 | 45 |
| LEFS25F□-700□ | 700 | 45 |
| LEFS25F□-750□ | 700 | 45 |
| LEFS25F□-800□ | 820 | 45 |

Dimensions: In-line Motor

LEFS32F

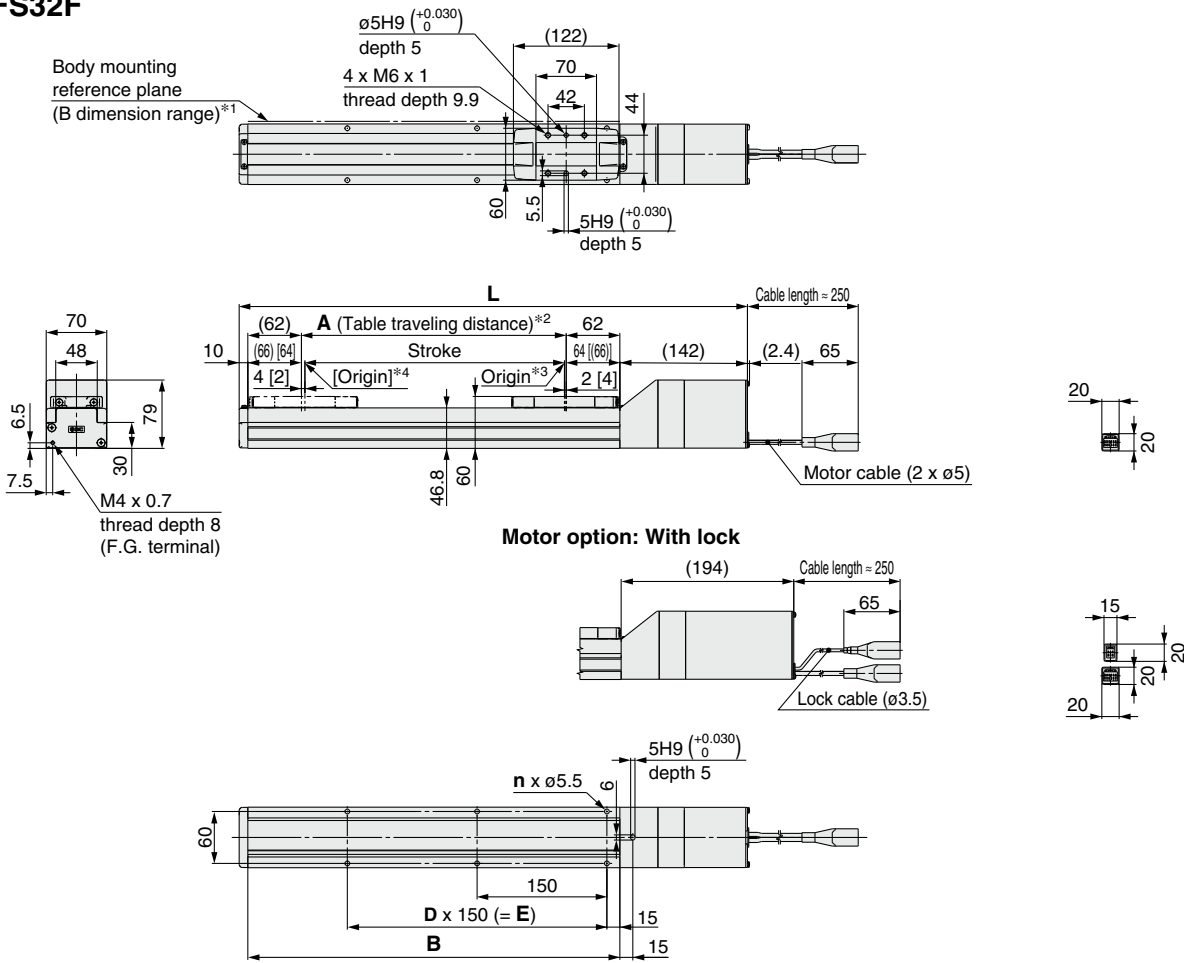

- *1 When mounting the actuator using the body mounting reference plane, set the height of the opposite surface or pin to be 3 mm or more because of round chamfering. (Recommended height 5 mm)
In addition, be aware that surfaces other than the body mounting reference plane (B dimension range) may slightly protrude from the body mounting reference plane. Be sure to provide a clearance of 1 mm or more to avoid interference with workpieces, facilities, etc.
- *2 This is the distance within which the table can move when it returns to origin.
Make sure workpieces mounted on the table do not interfere with the workpieces and facilities around the table.
- *3 Position after returning to origin
- *4 [] for when the direction of return to origin has changed

Dimensions

[mm]

| Model | L | | A | B | n | D | E |
|----------------|--------------|-----------|------|------|----|---|------|
| | Without lock | With lock | | | | | |
| LEFS32F□-50□ | 332 | 384 | 56 | 180 | 4 | — | — |
| LEFS32F□-100□ | 382 | 434 | 106 | 230 | 4 | — | — |
| LEFS32F□-150□ | 432 | 484 | 156 | 280 | 4 | — | — |
| LEFS32F□-200□ | 482 | 534 | 206 | 330 | 6 | 2 | 300 |
| LEFS32F□-250□ | 532 | 584 | 256 | 380 | 6 | 2 | 300 |
| LEFS32F□-300□ | 582 | 634 | 306 | 430 | 6 | 2 | 300 |
| LEFS32F□-350□ | 632 | 684 | 356 | 480 | 8 | 3 | 450 |
| LEFS32F□-400□ | 682 | 734 | 406 | 530 | 8 | 3 | 450 |
| LEFS32F□-450□ | 732 | 784 | 456 | 580 | 8 | 3 | 450 |
| LEFS32F□-500□ | 782 | 834 | 506 | 630 | 10 | 4 | 600 |
| LEFS32F□-550□ | 832 | 884 | 556 | 680 | 10 | 4 | 600 |
| LEFS32F□-600□ | 882 | 934 | 606 | 730 | 10 | 4 | 600 |
| LEFS32F□-650□ | 932 | 984 | 656 | 780 | 12 | 5 | 750 |
| LEFS32F□-700□ | 982 | 1034 | 706 | 830 | 12 | 5 | 750 |
| LEFS32F□-750□ | 1032 | 1084 | 756 | 880 | 12 | 5 | 750 |
| LEFS32F□-800□ | 1082 | 1134 | 806 | 930 | 14 | 6 | 900 |
| LEFS32F□-850□ | 1132 | 1184 | 856 | 980 | 14 | 6 | 900 |
| LEFS32F□-900□ | 1182 | 1234 | 906 | 1030 | 14 | 6 | 900 |
| LEFS32F□-950□ | 1232 | 1284 | 956 | 1080 | 16 | 7 | 1050 |
| LEFS32F□-1000□ | 1282 | 1334 | 1006 | 1130 | 16 | 7 | 1050 |

Dimensions: In-line Motor

LEFS32F

Positioning pin hole*1 (Option): Body bottom

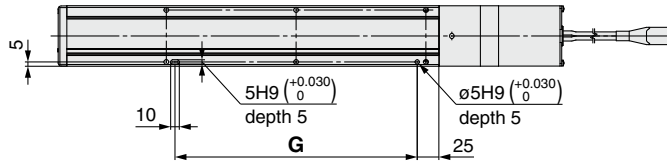

*1 When using the body bottom positioning pin holes, do not simultaneously use the housing B bottom pin hole.

With auto switch (Option)

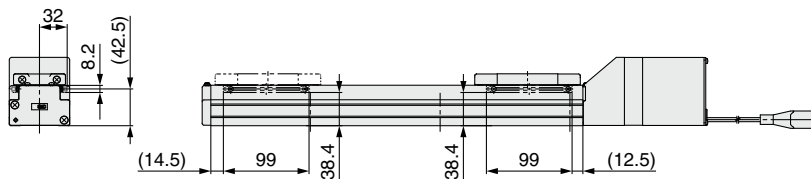

* For strokes of 99 mm or less, only 2 auto switch mounting brackets can be installed on the motor side.

Dimensions [mm]

| Model | G |
|----------------|------|
| LEFS32F□-50□ | 130 |
| LEFS32F□-100□ | 130 |
| LEFS32F□-150□ | 130 |
| LEFS32F□-200□ | 280 |
| LEFS32F□-250□ | 280 |
| LEFS32F□-300□ | 280 |
| LEFS32F□-350□ | 430 |
| LEFS32F□-400□ | 430 |
| LEFS32F□-450□ | 430 |
| LEFS32F□-500□ | 580 |
| LEFS32F□-550□ | 580 |
| LEFS32F□-600□ | 580 |
| LEFS32F□-650□ | 730 |
| LEFS32F□-700□ | 730 |
| LEFS32F□-750□ | 730 |
| LEFS32F□-800□ | 880 |
| LEFS32F□-850□ | 880 |
| LEFS32F□-900□ | 880 |
| LEFS32F□-950□ | 1030 |
| LEFS32F□-1000□ | 1030 |

Dimensions: In-line Motor

LEFS40F

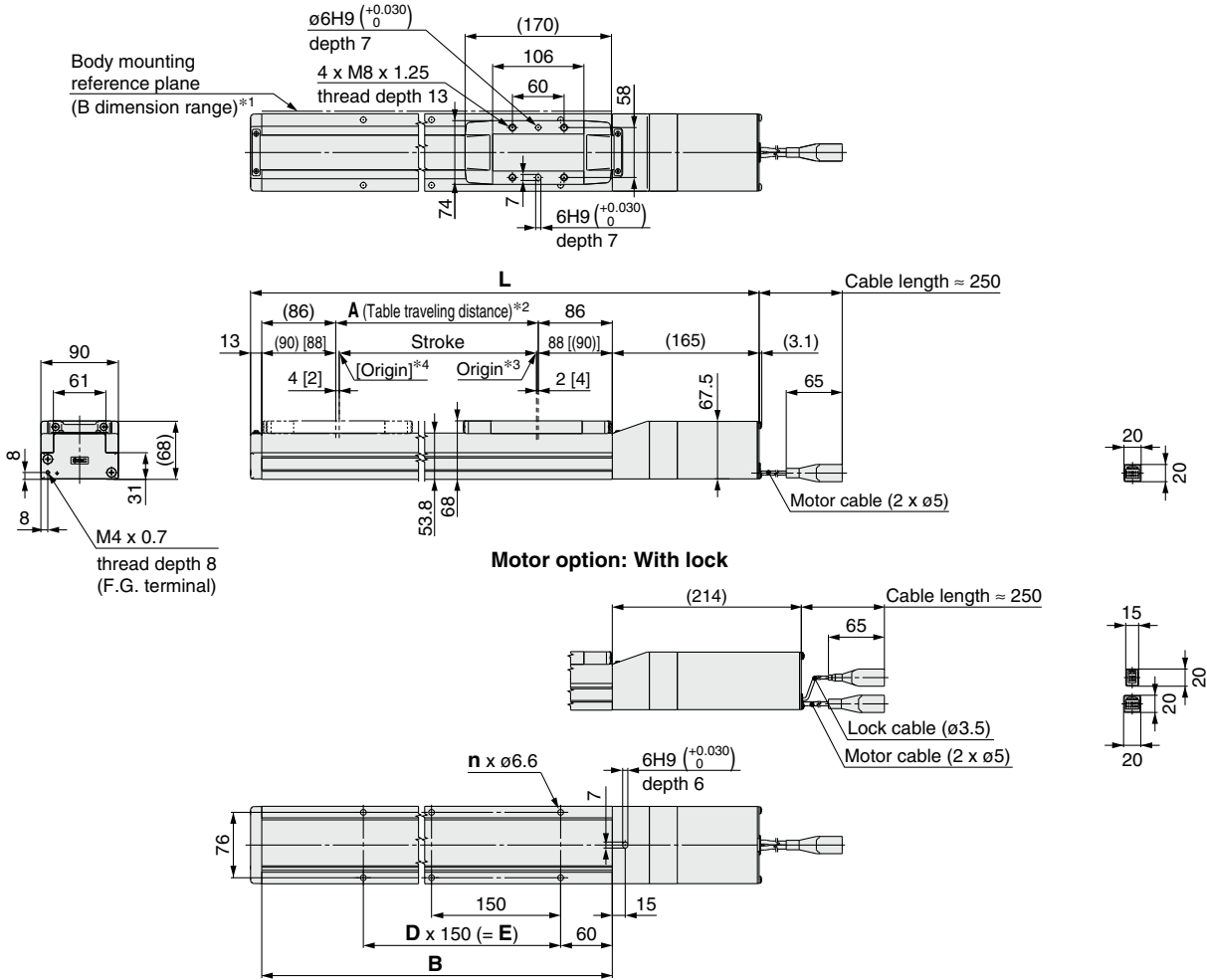

- *1 When mounting the actuator using the body mounting reference plane, set the height of the opposite surface or pin to be 3 mm or more because of round chamfering. (Recommended height 5 mm)
In addition, be aware that surfaces other than the body mounting reference plane (B dimension range) may slightly protrude from the body mounting reference plane. Be sure to provide a clearance of 1 mm or more to avoid interference with workpieces, facilities, etc.
- *2 This is the distance within which the table can move when it returns to origin.
Make sure workpieces mounted on the table do not interfere with the workpieces and facilities around the table.
- *3 Position after returning to origin
- *4 [] for when the direction of return to origin has changed

Dimensions

[mm]

| Model | L | | A | B | n | D | E |
|----------------|--------------|-----------|------|------|----|---|------|
| | Without lock | With lock | | | | | |
| LEFS40F□-150□ | 506 | 555 | 156 | 328 | 4 | — | 150 |
| LEFS40F□-200□ | 556 | 605 | 206 | 378 | 6 | 2 | 300 |
| LEFS40F□-250□ | 606 | 655 | 256 | 428 | 6 | 2 | 300 |
| LEFS40F□-300□ | 656 | 705 | 306 | 478 | 6 | 2 | 300 |
| LEFS40F□-350□ | 706 | 755 | 356 | 528 | 8 | 3 | 450 |
| LEFS40F□-400□ | 756 | 805 | 406 | 578 | 8 | 3 | 450 |
| LEFS40F□-450□ | 806 | 855 | 456 | 628 | 8 | 3 | 450 |
| LEFS40F□-500□ | 856 | 905 | 506 | 678 | 10 | 4 | 600 |
| LEFS40F□-550□ | 906 | 955 | 556 | 728 | 10 | 4 | 600 |
| LEFS40F□-600□ | 956 | 1005 | 606 | 778 | 10 | 4 | 600 |
| LEFS40F□-650□ | 1006 | 1055 | 656 | 828 | 12 | 5 | 750 |
| LEFS40F□-700□ | 1056 | 1105 | 706 | 878 | 12 | 5 | 750 |
| LEFS40F□-750□ | 1106 | 1155 | 756 | 928 | 12 | 5 | 750 |
| LEFS40F□-800□ | 1156 | 1205 | 806 | 978 | 14 | 6 | 900 |
| LEFS40F□-850□ | 1206 | 1255 | 856 | 1028 | 14 | 6 | 900 |
| LEFS40F□-900□ | 1256 | 1305 | 906 | 1078 | 14 | 6 | 900 |
| LEFS40F□-950□ | 1306 | 1355 | 956 | 1128 | 16 | 7 | 1050 |
| LEFS40F□-1000□ | 1356 | 1405 | 1006 | 1178 | 16 | 7 | 1050 |
| LEFS40F□-1100□ | 1456 | 1505 | 1106 | 1278 | 18 | 8 | 1200 |
| LEFS40F□-1200□ | 1556 | 1605 | 1206 | 1378 | 18 | 8 | 1200 |

LEFS□F Series

Dimensions: In-line Motor

LEFS40F

Positioning pin hole*1 (Option): Body bottom

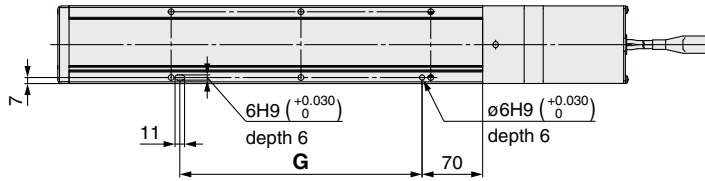

*1 When using the body bottom positioning pin holes, do not simultaneously use the housing B bottom pin hole.

With auto switch (Option)

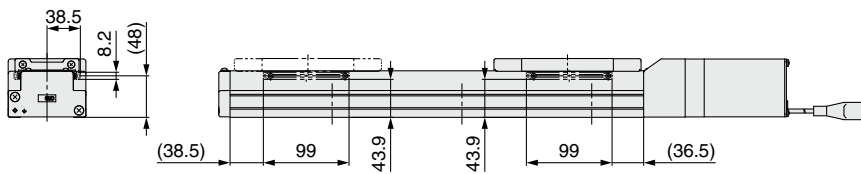

Dimensions [mm]

| Model | G |
|----------------|------|
| LEFS40F□-150□ | 130 |
| LEFS40F□-200□ | 280 |
| LEFS40F□-250□ | 280 |
| LEFS40F□-300□ | 280 |
| LEFS40F□-350□ | 430 |
| LEFS40F□-400□ | 430 |
| LEFS40F□-450□ | 430 |
| LEFS40F□-500□ | 580 |
| LEFS40F□-550□ | 580 |
| LEFS40F□-600□ | 580 |
| LEFS40F□-650□ | 730 |
| LEFS40F□-700□ | 730 |
| LEFS40F□-750□ | 730 |
| LEFS40F□-800□ | 880 |
| LEFS40F□-850□ | 880 |
| LEFS40F□-900□ | 880 |
| LEFS40F□-950□ | 1030 |
| LEFS40F□-1000□ | 1030 |
| LEFS40F□-1100□ | 1180 |
| LEFS40F□-1200□ | 1180 |

LEFS□F Series Auto Switch Mounting

Auto Switch Mounting Position

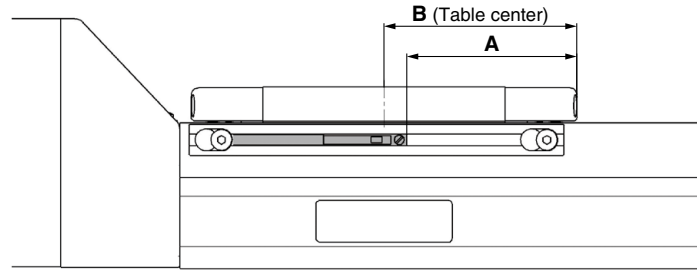

| [mm] | | | | |
|-------|------|----|----|-----------------|
| Model | Size | A | B | Operating range |
| LEFS | 25 | 45 | 51 | 4.9 |
| | 32 | 55 | 61 | 3.9 |
| | 40 | 79 | 85 | 5.3 |

- * The applicable auto switch is D-M9 (N/P/B) (W) (M/L/Z).
- * The operating range is a guideline including hysteresis, not meant to be guaranteed. There may be large variations depending on the ambient environment.
- * Adjust the auto switch after confirming the operating conditions in the actual setting.

Auto Switch Mounting

Rotate the bolts for auto switch mounting bracket three to four times to loosen them (Removing them is not required), and slide and remove the auto switch mounting bracket. Then, insert a switch into the groove on the mounting bracket.

As the mounting bolts for installing the product body interfere with the auto switch mounting bracket, mount the auto switch mounting bracket after installing the product body. After installing product body, tighten the bolts for the auto switch mounting bracket.

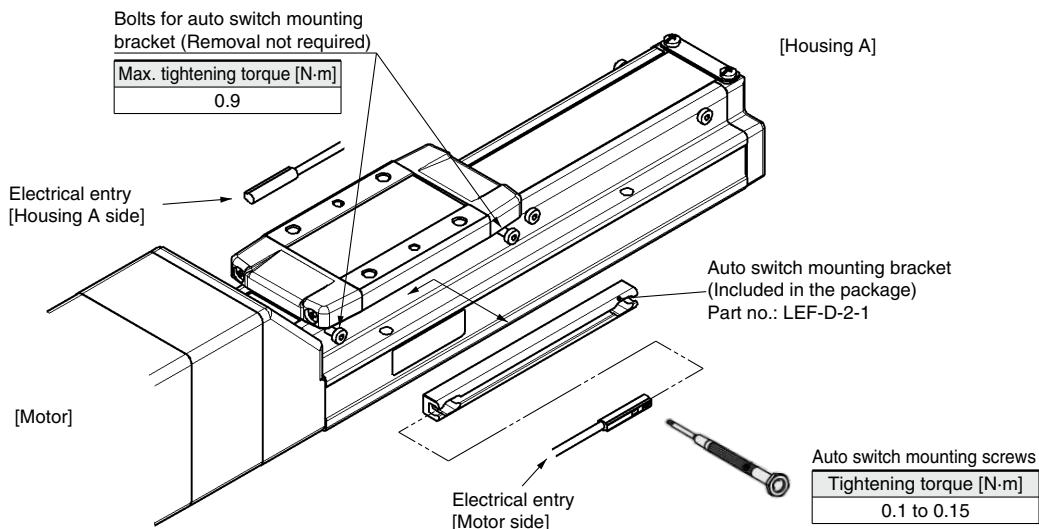

- * The applicable auto switch is D-M9 (N/P/B) (W) (M/L/Z).
- * The direction of the lead wire entry is specified. If it is mounted in the opposite direction, the auto switch may malfunction.
- * Tighten the auto switch mounting screws (provided together with the auto switch), using a precision screwdriver with a handle diameter of approximately 5 to 6 mm.
- * If more than two auto switch mounting brackets are required, please order them separately. All eight bolts for attaching the auto switch mounting bracket at the stroke end are tightened into the body when the product is shipped. For 50-mm stroke type, only four bolts are tightened on the motor side.

Solid State Auto Switch Direct Mounting Type D-M9N/D-M9P/D-M9B



Refer to the SMC website for details on products that are compliant with international standards.

Auto Switch Specifications

PLC: Programmable Logic Controller

| D-M9□, D-M9□V (With indicator light) | | | |
|--------------------------------------|---|-------|-----------------------|
| Auto switch model | D-M9N | D-M9P | D-M9B |
| Electrical entry direction | In-line | | |
| Wiring type | 3-wire | | 2-wire |
| Output type | NPN | PNP | — |
| Applicable load | IC circuit, Relay, PLC | | 24 VDC relay, PLC |
| Power supply voltage | 5, 12, 24 VDC (4.5 to 28 V) | | — |
| Current consumption | 10 mA or less | | — |
| Load voltage | 28 VDC or less | — | 24 VDC (10 to 28 VDC) |
| Load current | 40 mA or less | | 2.5 to 40 mA |
| Internal voltage drop | 0.8 V or less at 10 mA (2 V or less at 40 mA) | | 4 V or less |
| Leakage current | 100 μA or less at 24 VDC | | 0.8 mA or less |
| Indicator light | Red LED illuminates when turned ON. | | |
| Standard | CE marking, RoHS | | |

Grommet

- 2-wire load current is reduced (2.5 to 40 mA).
- Using flexible cable as standard spec.



Caution

Precautions

Fix the auto switch with the existing screw installed on the auto switch body. The auto switch may be damaged if a screw other than the one supplied is used.

Oilproof Heavy-duty Lead Wire Specifications

| Auto switch model | | D-M9N | D-M9P | D-M9B |
|--|-----------------------------------|----------------------------|-------|----------------------|
| Sheath | Outside diameter [mm] | 2.6 | | |
| Insulator | Number of cores | 3 cores (Brown/Blue/Black) | | 2 cores (Brown/Blue) |
| | Outside diameter [mm] | 0.88 | | |
| Conductor | Effective area [mm ²] | 0.15 | | |
| | Strand diameter [mm] | 0.05 | | |
| Minimum bending radius [mm] (Reference values) | | 17 | | |

* Refer to the **Web Catalog** for solid state auto switch common specifications.

* Refer to the **Web Catalog** for lead wire lengths.

Weight

[g]

| Auto switch model | | D-M9N | D-M9P | D-M9B |
|-------------------|-------------|-------|-------|-------|
| Lead wire length | 0.5 m (Nil) | 8 | | 7 |
| | 1 m (M) | 14 | | 13 |
| | 3 m (L) | 41 | | 38 |
| | 5 m (Z) | 68 | | 63 |

Dimensions

[mm]

D-M9□

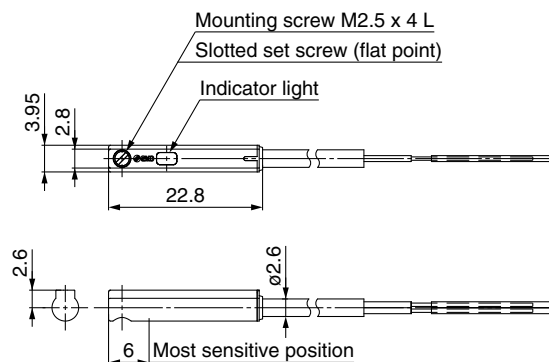

Normally Closed Solid State Auto Switch Direct Mounting Type

D-M9NE(V)/D-M9PE(V)/D-M9BE(V)

Refer to the SMC website for details on products that are compliant with international standards.

PLC: Programmable Logic Controller

Grommet

- Output signal turns on when no magnetic force is detected.
- Can be used for the actuator adopted by the solid state auto switch D-M9 series (excluding special order products)

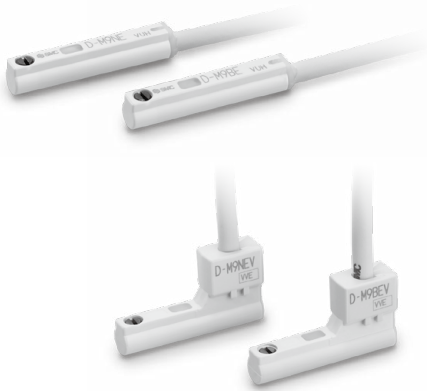

Caution

Precautions

Fix the auto switch with the existing screw installed on the auto switch body. The auto switch may be damaged if a screw other than the one supplied is used.

Auto Switch Specifications

| D-M9□E, D-M9□EV (With indicator light) | | | | | | |
|--|---|---------------|---------|---------------|-----------------------|---------------|
| Auto switch model | D-M9NE | D-M9NEV | D-M9PE | D-M9PEV | D-M9BE | D-M9BEV |
| Electrical entry direction | In-line | Perpendicular | In-line | Perpendicular | In-line | Perpendicular |
| Wiring type | 3-wire | | | | 2-wire | |
| Output type | NPN | | PNP | | — | |
| Applicable load | IC circuit, Relay, PLC | | | | 24 VDC relay, PLC | |
| Power supply voltage | 5, 12, 24 VDC (4.5 to 28 V) | | | | — | |
| Current consumption | 10 mA or less | | | | — | |
| Load voltage | 28 VDC or less | | — | | 24 VDC (10 to 28 VDC) | |
| Load current | 40 mA or less | | | | 2.5 to 40 mA | |
| Internal voltage drop | 0.8 V or less at 10 mA (2 V or less at 40 mA) | | | | 4 V or less | |
| Leakage current | 100 μA or less at 24 VDC | | | | 0.8 mA or less | |
| Indicator light | Red LED illuminates when turned ON. | | | | | |
| Standard | CE marking, RoHS | | | | | |

Oilproof Heavy-duty Lead Wire Specifications

| Auto switch model | | D-M9NE(V) | D-M9PE(V) | D-M9BE(V) |
|--|-----------------------------------|----------------------------|-----------|----------------------|
| Sheath | Outside diameter [mm] | 2.6 | | |
| Insulator | Number of cores | 3 cores (Brown/Blue/Black) | | 2 cores (Brown/Blue) |
| | Outside diameter [mm] | 0.88 | | |
| Conductor | Effective area [mm ²] | 0.15 | | |
| | Strand diameter [mm] | 0.05 | | |
| Minimum bending radius [mm] (Reference values) | | 17 | | |

- * Refer to the **Web Catalog** for solid state auto switch common specifications.
- * Refer to the **Web Catalog** for lead wire lengths.

Weight

| Auto switch model | | D-M9NE(V) | D-M9PE(V) | D-M9BE(V) |
|-------------------|-------------|-----------|-----------|-----------|
| Lead wire length | 0.5 m (Nil) | 8 | 7 | 7 |
| | 1 m (M)*1 | 14 | 13 | 13 |
| | 3 m (L) | 41 | 38 | 38 |
| | 5 m (Z)*1 | 68 | 63 | 63 |

*1 The 1 m and 5 m options are produced upon receipt of order.

Dimensions

D-M9□E

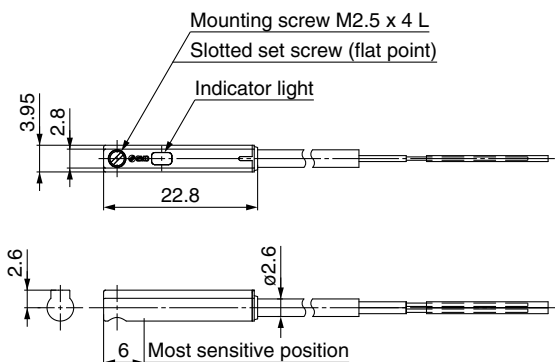

D-M9□EV

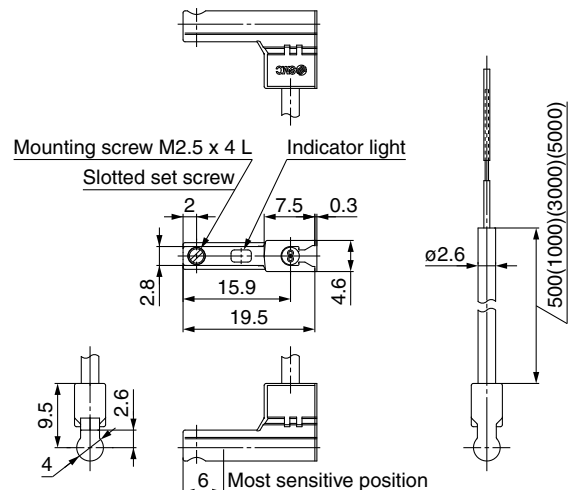

2-Color Indicator Solid State Auto Switch Direct Mounting Type

D-M9NW/D-M9PW/D-M9BW



Refer to the SMC website for details on products that are compliant with international standards.

Grommet

- 2-wire load current is reduced (2.5 to 40 mA).
- Using flexible cable as standard spec.
- The proper operating range can be determined by the color of the light. (Red → Green ← Red)



Caution

Precautions

Fix the auto switch with the existing screw installed on the auto switch body. The auto switch may be damaged if a screw other than the one supplied is used.

Auto Switch Specifications

PLC: Programmable Logic Controller

| D-M9□W, D-M9□WV (With indicator light) | | | |
|--|---|--------|-----------------------|
| Auto switch model | D-M9NW | D-M9PW | D-M9BW |
| Electrical entry direction | In-line | | |
| Wiring type | 3-wire | | 2-wire |
| Output type | NPN | PNP | — |
| Applicable load | IC circuit, Relay, PLC | | 24 VDC relay, PLC |
| Power supply voltage | 5, 12, 24 VDC (4.5 to 28 V) | | — |
| Current consumption | 10 mA or less | | |
| Load voltage | 28 VDC or less | — | 24 VDC (10 to 28 VDC) |
| Load current | 40 mA or less | | 2.5 to 40 mA |
| Internal voltage drop | 0.8 V or less at 10 mA (2 V or less at 40 mA) | | 4 V or less |
| Leakage current | 100 μA or less at 24 VDC | | 0.8 mA or less |
| Indicator light | Operating range Red LED illuminates. Proper operating range Green LED illuminates. | | |
| Standard | CE marking, RoHS | | |

Oilproof Flexible Heavy-duty Lead Wire Specifications

| Auto switch model | | D-M9NW | D-M9PW | D-M9BW |
|--|-----------------------------------|----------------------------|--------|----------------------|
| Sheath | Outside diameter [mm] | 2.6 | | |
| Insulator | Number of cores | 3 cores (Brown/Blue/Black) | | 2 cores (Brown/Blue) |
| | Outside diameter [mm] | 0.88 | | |
| Conductor | Effective area [mm ²] | 0.15 | | |
| | Strand diameter [mm] | 0.05 | | |
| Minimum bending radius [mm] (Reference values) | | 17 | | |

- * Refer to the **Web Catalog** for solid state auto switch common specifications.
- * Refer to the **Web Catalog** for lead wire lengths.

Weight

[g]

| Auto switch model | | D-M9NW | D-M9PW | D-M9BW |
|-------------------|-------------|--------|--------|--------|
| Lead wire length | 0.5 m (Nil) | 8 | 7 | 7 |
| | 1 m (M) | 14 | 13 | 13 |
| | 3 m (L) | 41 | 38 | 38 |
| | 5 m (Z) | 68 | 63 | 63 |

Dimensions

[mm]

D-M9□W

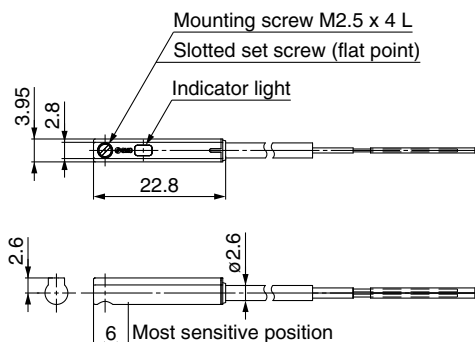

High Performance Controller (Step Data Input Type)

JXC5H/6H Series



Model Selection

LEFS□F

Auto Switch

JXC5H/6H

How to Order

JXC **5** **H** **7** **3** - □

① ② ③ ④ ⑤

① Controller type

| | |
|---|-------------------------|
| 5 | Parallel I/O (NPN) type |
| 6 | Parallel I/O (PNP) type |

② Specification

| | |
|---|-----------------------|
| H | High performance type |
|---|-----------------------|

③ Mounting

| | |
|---|----------------|
| 7 | Screw mounting |
| 8 | DIN rail |

④ I/O cable length

| | |
|-----|-------|
| Nil | None |
| 1 | 1.5 m |
| 3 | 3 m |
| 5 | 5 m |

⑤ Actuator part number

| | |
|--|--------------------|
| Without cable specifications and actuator options Example: Enter "LEFS25FA-100" for the LEFS25FA-100B-R1□. | |
| BC | Blank controller*1 |

*1 Requires dedicated software (JXC-BCW)

The controller is sold as single unit after the compatible actuator is set.

Connect to an actuator (LEFS□F) designated for a high performance controller. Confirm that the combination of the controller and actuator is correct.

<Check the following before use.>

- Check the actuator label for the model number. This number should match that of the controller.
- Check that the Parallel I/O configuration matches (NPN or PNP).

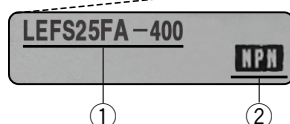

* Refer to the operation manual for using the products. Please download it via our website:
<https://www.smcworld.com>

Specifications

| Model | JXC5H JXC6H |
|----------------------------------|---|
| Compatible motor | Step motor (Servo/24 VDC) |
| Power supply | Power supply voltage: 24 VDC ±10% |
| Current consumption (Controller) | 100 mA or less |
| Compatible encoder | Incremental A/B phase (800 pulse/rotation) |
| Parallel input | 11 inputs (Photo-coupler isolation) |
| Parallel output | 13 outputs (Photo-coupler isolation) |
| Serial communication | RS485 (Only for the LEC-T1 and JXC-W2) |
| Memory | EEPROM |
| LED indicator | PWR, ALM |
| Cable length [m] | Actuator cable: 20 or less |
| Cooling system | Natural air cooling |
| Operating temperature range [°C] | 0 to 40 |
| Operating humidity range [%RH] | 90 or less (No condensation) |
| Insulation resistance [MΩ] | Between all external terminals and the case: 50 (500 VDC) |
| Weight [g] | 180 (Screw mounting), 200 (DIN rail mounting) |

JXC5H/6H Series

How to Mount

a) Screw mounting (JXC□H7□) (Installation with two M4 screws)

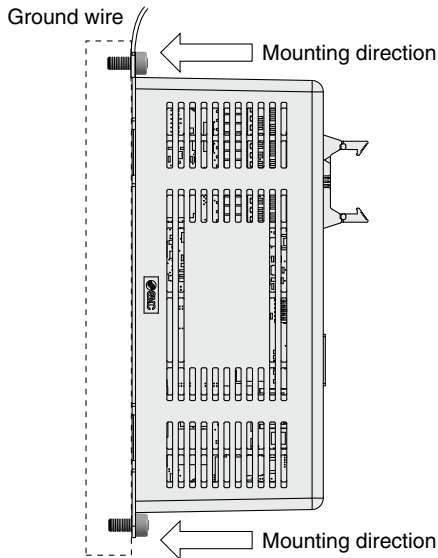

b) DIN rail mounting (JXC□H8□) (Installation with the DIN rail)

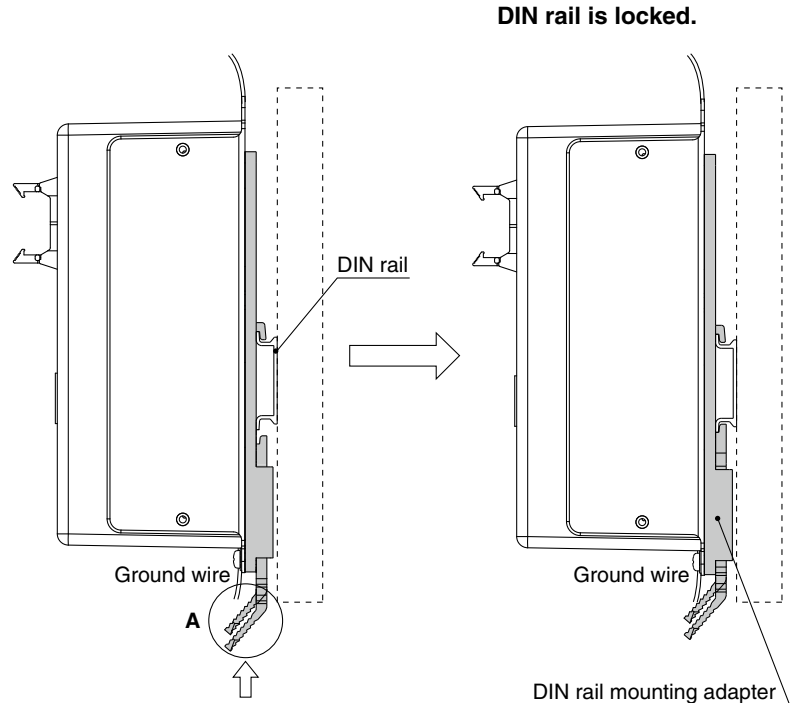

Hook the controller on the DIN rail and press the lever of section A in the arrow direction to lock it.

* When size 25 or more of the LE series are used, the space between the controllers should be 10 mm or more.

DIN rail AXT100-DR-□

* For □, enter a number from the No. line in the table below.
Refer to the dimension drawings on page 26 for the mounting dimensions.

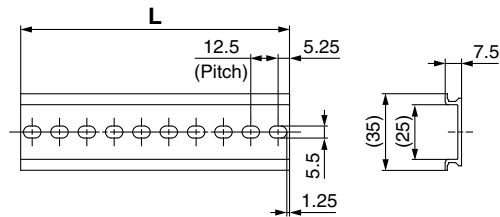

L Dimensions [mm]

| | | | | | | | | | | | | | | | | | | | | |
|-----|-----|-------|-----|-------|-----|-------|-----|-------|-----|-------|-----|-------|-----|-------|-----|-------|-----|-------|-----|-------|
| No. | 1 | 2 | 3 | 4 | 5 | 6 | 7 | 8 | 9 | 10 | 11 | 12 | 13 | 14 | 15 | 16 | 17 | 18 | 19 | 20 |
| L | 23 | 35.5 | 48 | 60.5 | 73 | 85.5 | 98 | 110.5 | 123 | 135.5 | 148 | 160.5 | 173 | 185.5 | 198 | 210.5 | 223 | 235.5 | 248 | 260.5 |
| No. | 21 | 22 | 23 | 24 | 25 | 26 | 27 | 28 | 29 | 30 | 31 | 32 | 33 | 34 | 35 | 36 | 37 | 38 | 39 | 40 |
| L | 273 | 285.5 | 298 | 310.5 | 323 | 335.5 | 348 | 360.5 | 373 | 385.5 | 398 | 410.5 | 423 | 435.5 | 448 | 460.5 | 473 | 485.5 | 498 | 510.5 |

DIN rail mounting adapter LEC-D0 (with 2 mounting screws)

This should be used when the DIN rail mounting adapter is mounted onto a screw mounting type controller afterward.

Dimensions

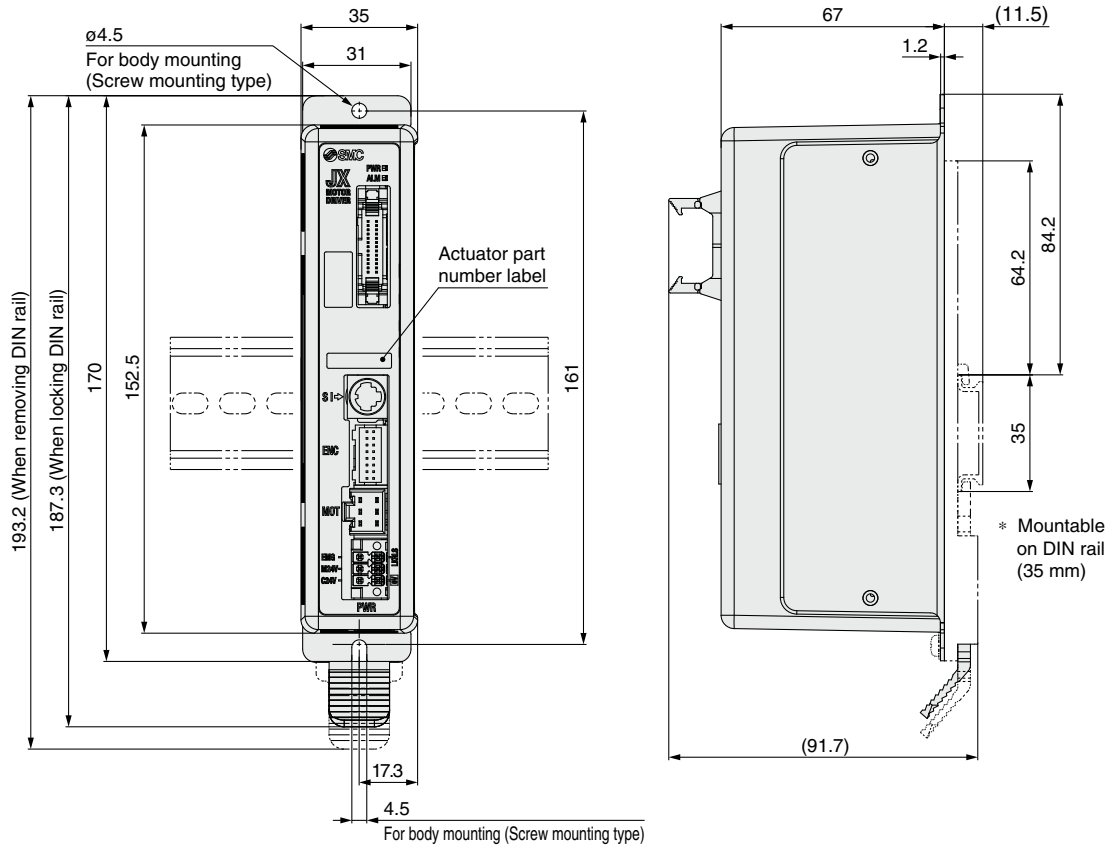

Model Selection

LEFS F

Auto Switch

JXC5H/6H

JXC5H/6H Series

Wiring Example 1

Parallel I/O Connector

- * When you connect a PLC to the parallel I/O connector, use the I/O cable (LEC-CN5-□).
- * The wiring changes depending on the type of parallel I/O (NPN or PNP).

Wiring diagram JXC5H□□ (NPN)

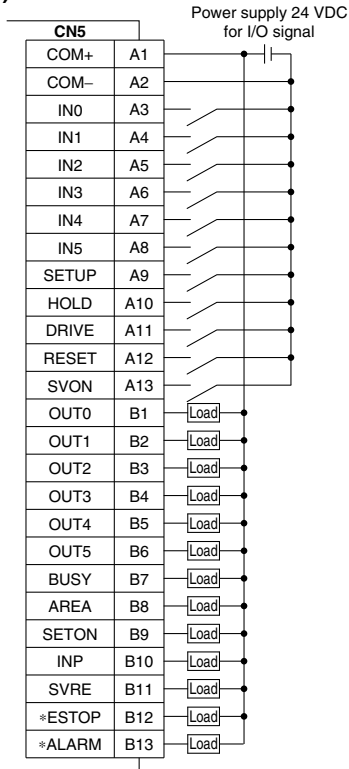

JXC6H□□ (PNP)

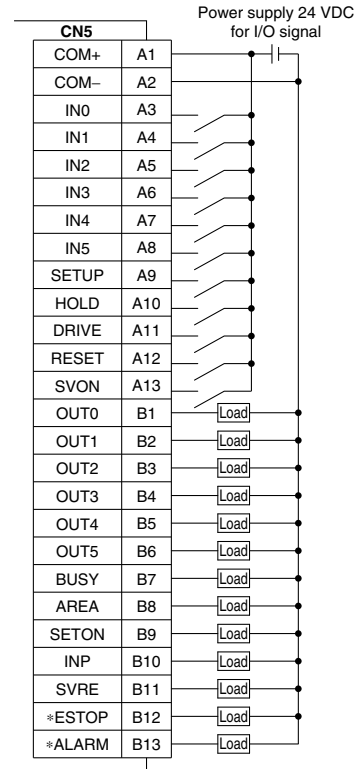

Input Signal

| Name | Details |
|------------|---|
| COM+ | Connects the power supply 24 V for input/output signal |
| COM- | Connects the power supply 0 V for input/output signal |
| IN0 to IN5 | Step data specified bit no. (Input is instructed by combining IN0 to 5.) |
| SETUP | Instruction to return to origin |
| HOLD | Temporarily stops operation |
| DRIVE | Instruction to drive |
| RESET | Resets alarm and interrupts operation |
| SVON | Servo ON instruction |

Output Signal

| Name | Details |
|----------------------|---|
| OUT0 to OUT5 | Outputs the step data no. during operation |
| BUSY | Outputs when the actuator is moving |
| AREA | Outputs within the step data area output setting range |
| SETON | Outputs when returning to origin |
| INP | Outputs when target position or target force is reached (Turns on when the positioning or pushing is completed.) |
| SVRE | Outputs when servo is on |
| *ESTOP* ¹ | OFF when EMG stop is instructed |
| *ALARM* ¹ | OFF when alarm is generated |

*¹ Signal of negative-logic circuit (N.C.)

Step Data Setting

1. Step data setting for positioning

In this setting, the actuator moves toward and stops at the target position.

The following diagram shows the setting items and operation.

The setting items and set values for this operation are stated below.

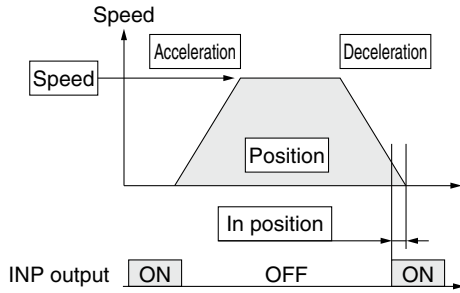

- ◎ : Need to be set.
- : Need to be adjusted as required.
- : Setting is not required.

Step Data (Positioning)

| Necessity | Item | Details |
|-----------|----------------|--|
| ◎ | Movement MOD | When the absolute position is required, set Absolute. When the relative position is required, set Relative. |
| ◎ | Speed | Transfer speed to the target position |
| ◎ | Position | Target position |
| ○ | Acceleration | Parameter which defines how rapidly the actuator reaches the speed set. The higher the set value, the faster it reaches the speed set. |
| ○ | Deceleration | Parameter which defines how rapidly the actuator comes to stop. The higher the set value, the quicker it stops. |
| ◎ | Pushing force | Set 0. (If values 1 to 100 are set, the operation will be changed to the pushing operation.) |
| — | Trigger LV | Setting is not required. |
| — | Pushing speed | Setting is not required. |
| ○ | Moving force | Max. torque during the positioning operation (No specific change is required.) |
| ○ | Area 1, Area 2 | Condition that turns on the AREA output signal. |
| ○ | In position | Condition that turns on the INP output signal. When the actuator enters the range of [in position], the INP output signal turns on. (It is unnecessary to change this from the initial value.) When it is necessary to output the arrival signal before the operation is completed, make the value larger. |

2. Step data setting for pushing

The actuator moves toward the pushing start position, and when it reaches that position, it starts pushing with the set force or less.

The following diagram shows the setting items and operation. The setting items and set values for this operation are stated below.

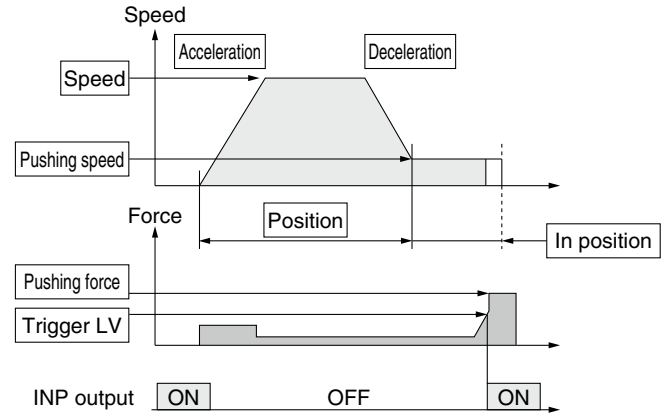

- ◎ : Need to be set.
- : Need to be adjusted as required.

Step Data (Pushing)

| Necessity | Item | Details |
|-----------|----------------|---|
| ◎ | Movement MOD | When the absolute position is required, set Absolute. When the relative position is required, set Relative. |
| ◎ | Speed | Transfer speed to the pushing start position |
| ◎ | Position | Pushing start position |
| ○ | Acceleration | Parameter which defines how rapidly the actuator reaches the speed set. The higher the set value, the faster it reaches the speed set. |
| ○ | Deceleration | Parameter which defines how rapidly the actuator comes to stop. The higher the set value, the quicker it stops. |
| ◎ | Pushing force | Pushing force ratio is defined. The setting range differs depending on the electric actuator type. Refer to the operation manual for the electric actuator. |
| ◎ | Trigger LV | Condition that turns on the INP output signal. The INP output signal turns on when the generated force exceeds the value. Trigger level should be the pushing force or less. |
| ○ | Pushing speed | Pushing speed during pushing. When the speed is set fast, the electric actuator and workpieces might be damaged due to the impact when they hit the end, so this set value should be smaller. Refer to the operation manual for the electric actuator. |
| ○ | Moving force | Max. torque during the positioning operation (No specific change is required.) |
| ○ | Area 1, Area 2 | Condition that turns on the AREA output signal. |
| ◎ | In position | Transfer distance during pushing. If the transferred distance exceeds the setting, it stops even if it is not pushing. If the transfer distance is exceeded, the INP output signal will not turn on. |

JXC5H/6H Series

Signal Timing

Return to Origin

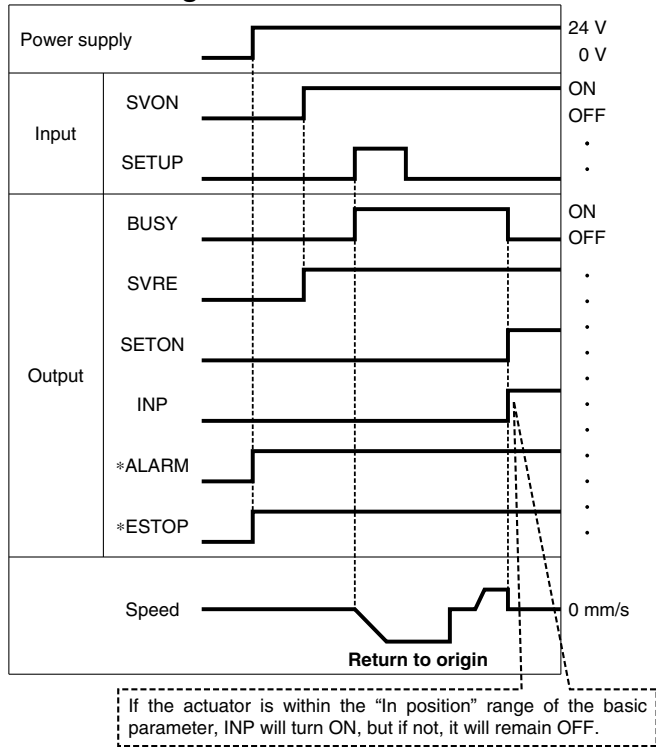

* *ALARM* and *ESTOP* are expressed as negative-logic circuits.

Positioning Operation

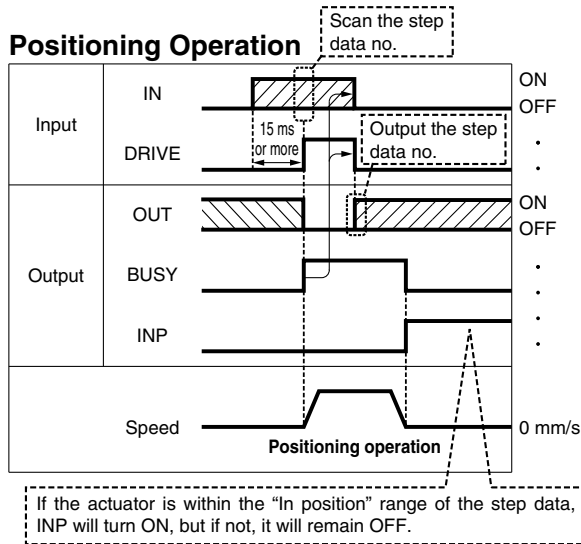

* "OUT" is output when "DRIVE" is changed from ON to OFF.
Refer to the operation manual for details on the controller for the LEM series.
(When power supply is applied, "DRIVE" or "RESET" is turned ON or *ESTOP* is turned OFF, all of the "OUT" outputs are OFF.)

HOLD

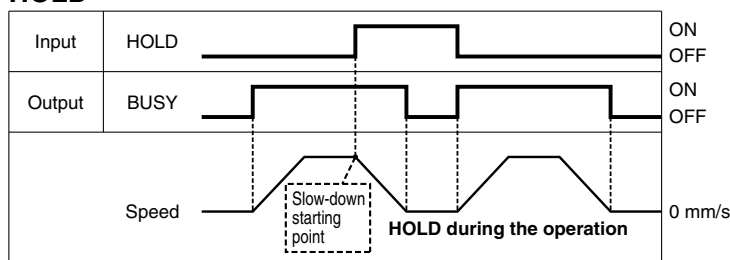

* When the actuator is within the "In position" range in the pushing operation, it does not stop even if HOLD signal is input.

Pushing Operation

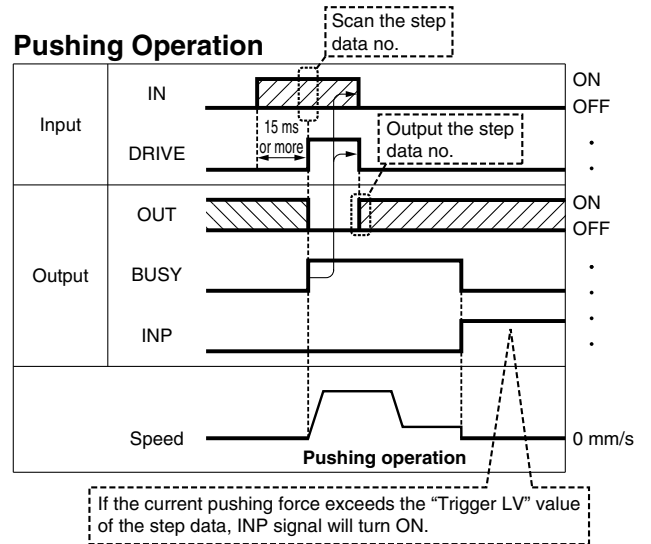

Reset

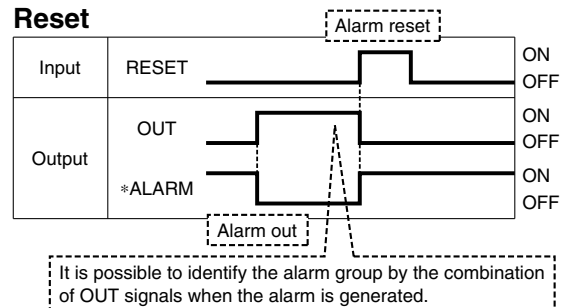

* *ALARM* is expressed as a negative-logic circuit.

Options

Power supply plug JXC-CPW

- * The power supply plug is an accessory.
- <Applicable cable size> AWG20 (0.5 mm²), cover diameter 2.0 mm or less

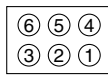
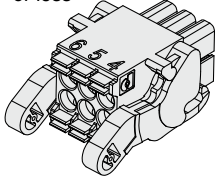

- ① C24V
- ② M24V
- ③ EMG
- ④ 0V
- ⑤ N.C.
- ⑥ LK RLS

Power supply plug terminal

| Terminal name | Function | Details |
|---------------|--------------------------|--|
| 0V | Common supply (-) | M24V terminal/C24V terminal/EMG terminal/LK RLS terminal are common (-). |
| M24V | Motor power supply (+) | Motor power supply (+) of the controller |
| C24V | Control power supply (+) | Control power supply (+) of the controller |
| EMG | Stop (+) | Connection terminal of the external stop circuit |
| LK RLS | Lock release (+) | Connection terminal of the lock release switch |

Communication cable for controller setting

- Controller setting software
 - USB driver
- Download from SMC's website:
<https://www.smcworld.com>

Hardware Requirements

| | |
|-------------------------|------------------------------------|
| OS | Windows®7, Windows®8.1, Windows®10 |
| Communication interface | USB 1.1 or USB 2.0 ports |
| Display | 1024 x 768 or more |

- * Windows®7, Windows®8.1, and Windows®10 are registered trademarks of Microsoft Corporation in the United States.

① Communication cable JXC-W2A-C

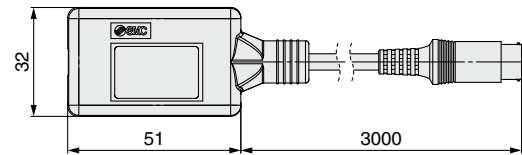

- * It can be connected to the controller directly.

② USB cable LEC-W2-U

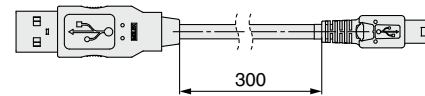

Teaching box

LEC-T1-3 J G

Teaching box

Cable length [m]
3 3

Initial language

| | |
|---|----------|
| J | Japanese |
| E | English |

Enable switch

| | |
|-----|-----------------------------|
| Nil | None |
| S | Equipped with enable switch |

- * Interlock switch for jog and test function

Stop switch

| | |
|---|---------------------------|
| G | Equipped with stop switch |
|---|---------------------------|

- * The displayed language can be changed to English or Japanese.

Specifications

| Item | Description |
|----------------------------------|-------------------------------------|
| Switch | Stop switch, Enable switch (Option) |
| Cable length [m] | 3 |
| Enclosure | IP64 (Except connector) |
| Operating temperature range [°C] | 5 to 50 |
| Operating humidity range [%RH] | 90 or less (No condensation) |
| Weight [g] | 350 (Except cable) |

- * To connect the teaching box (LEC-T1-3□G□) to the controller, a conversion cable (P5062-5) is required. (Refer to page 31.)



JXC5H/6H Series

Options

■ Conversion cable P5062-5 (Cable length: 300 mm)

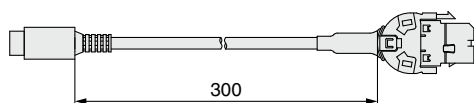

* To connect the teaching box (LEC-T1-3□G□) to the controller, a conversion cable is required.

■ I/O cable

LEC-CN5-1

Cable length (L) [m]

| | |
|---|-----|
| 1 | 1.5 |
| 3 | 3 |
| 5 | 5 |

* Conductor size: AWG28

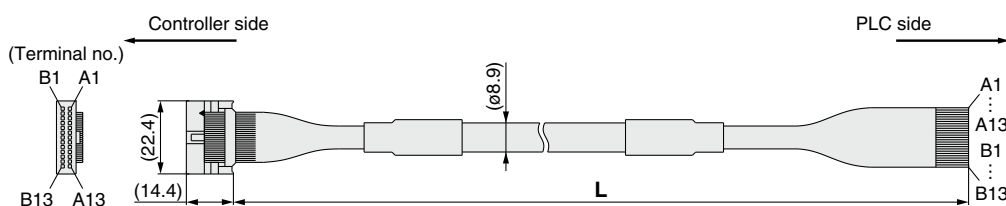

| Connector pin no. | Insulation color | Dot mark | Dot color |
|-------------------|------------------|----------|-----------|
| A1 | Light brown | ■ | Black |
| A2 | Light brown | ■ | Red |
| A3 | Yellow | ■ | Black |
| A4 | Yellow | ■ | Red |
| A5 | Light green | ■ | Black |
| A6 | Light green | ■ | Red |
| A7 | Gray | ■ | Black |
| A8 | Gray | ■ | Red |
| A9 | White | ■ | Black |
| A10 | White | ■ | Red |
| A11 | Light brown | ■ ■ | Black |
| A12 | Light brown | ■ ■ | Red |
| A13 | Yellow | ■ ■ | Black |

| Connector pin no. | Insulation color | Dot mark | Dot color |
|-------------------|------------------|----------|-----------|
| B1 | Yellow | ■ ■ | Red |
| B2 | Light green | ■ ■ | Black |
| B3 | Light green | ■ ■ | Red |
| B4 | Gray | ■ ■ | Black |
| B5 | Gray | ■ ■ | Red |
| B6 | White | ■ ■ | Black |
| B7 | White | ■ ■ | Red |
| B8 | Light brown | ■ ■ ■ | Black |
| B9 | Light brown | ■ ■ ■ | Red |
| B10 | Yellow | ■ ■ ■ | Black |
| B11 | Yellow | ■ ■ ■ | Red |
| B12 | Light green | ■ ■ ■ | Black |
| B13 | Light green | ■ ■ ■ | Red |
| — | Shield | | |

Weight

| Product no. | Weight [g] |
|-------------|------------|
| LEC-CN5-1 | 170 |
| LEC-CN5-3 | 320 |
| LEC-CN5-5 | 520 |

■ Trademark

EtherNet/IP™ is a trademark of ODVA.

DeviceNet™ is a trademark of ODVA.

EtherCAT® is registered trademark and patented technology, licensed by Beckhoff Automation GmbH, Germany.

Options: Actuator Cable

[Robotic cable, standard cable for step motor (Servo/24 VDC)]

LE-CP-1 - []

Cable length (L) [m]

| | |
|---|------|
| 1 | 1.5 |
| 3 | 3 |
| 5 | 5 |
| 8 | 8*1 |
| A | 10*1 |
| B | 15*1 |
| C | 20*1 |

*1 Produced upon receipt of order (Robotic cable only)

Cable type

| | |
|-----|--------------------------------|
| Nil | Robotic cable (Flexible cable) |
| S | Standard cable |

Weight

| Product no. | Weight [g] | Note |
|-------------|------------|----------------|
| LE-CP-1-S | 190 | Standard cable |
| LE-CP-3-S | 280 | |
| LE-CP-5-S | 460 | |
| LE-CP-1 | 140 | Robotic cable |
| LE-CP-3 | 260 | |
| LE-CP-5 | 420 | |
| LE-CP-8 | 790 | |
| LE-CP-A | 980 | |
| LE-CP-B | 1460 | |
| LE-CP-C | 1940 | |

LE-CP-¹/₅ / Cable length: 1.5 m, 3 m, 5 m

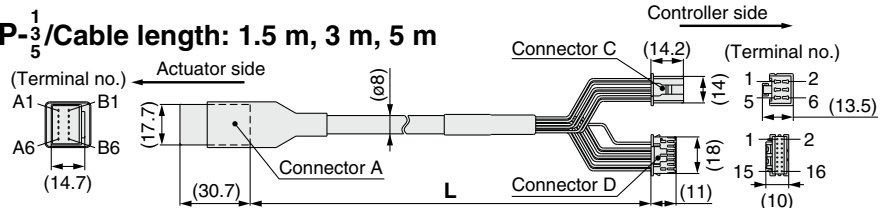

LE-CP-^{8 B}/_{A C} / Cable length: 8 m, 10 m, 15 m, 20 m
(*1 Produced upon receipt of order)

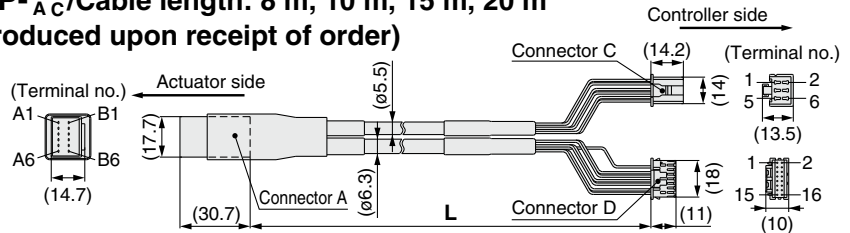

| Signal | Connector A terminal no. | Cable color | Connector C terminal no. |
|-----------|--------------------------|-------------|--------------------------|
| A | B-1 | Brown | 2 |
| A | A-1 | Red | 1 |
| B | B-2 | Orange | 6 |
| B | A-2 | Yellow | 5 |
| COM-A/COM | B-3 | Green | 3 |
| COM-B/- | A-3 | Blue | 4 |
| Shield | | | |
| Vcc | B-4 | Brown | 12 |
| GND | A-4 | Black | 13 |
| A | B-5 | Red | 7 |
| A | A-5 | Black | 6 |
| B | B-6 | Orange | 9 |
| B | A-6 | Black | 8 |
| | | | 3 |

[Robotic cable, standard cable with lock and sensor for step motor (Servo/24 VDC)]

LE-CP-1-B - []

Cable length (L) [m]

| | |
|---|------|
| 1 | 1.5 |
| 3 | 3 |
| 5 | 5 |
| 8 | 8*1 |
| A | 10*1 |
| B | 15*1 |
| C | 20*1 |

*1 Produced upon receipt of order (Robotic cable only)

With lock and sensor

Cable type

| | |
|-----|--------------------------------|
| Nil | Robotic cable (Flexible cable) |
| S | Standard cable |

Weight

| Product no. | Weight [g] | Note |
|-------------|------------|----------------|
| LE-CP-1-B-S | 240 | Standard cable |
| LE-CP-3-B-S | 380 | |
| LE-CP-5-B-S | 630 | |
| LE-CP-1-B | 190 | Robotic cable |
| LE-CP-3-B | 360 | |
| LE-CP-5-B | 590 | |
| LE-CP-8-B | 1060 | |
| LE-CP-A-B | 1320 | |
| LE-CP-B-B | 1920 | |
| LE-CP-C-B | 2620 | |

LE-CP-¹/₅ / Cable length: 1.5 m, 3 m, 5 m

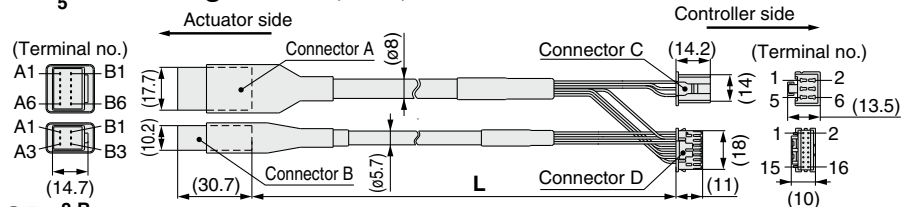

LE-CP-^{8 B}/_{A C} / Cable length: 8 m, 10 m, 15 m, 20 m
(*1 Produced upon receipt of order)

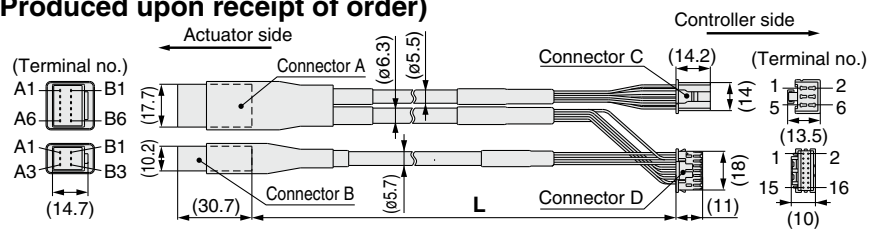



| Signal | Connector A terminal no. | Cable color | Connector C terminal no. |
|-----------|--------------------------|-------------|--------------------------|
| A | B-1 | Brown | 2 |
| A | A-1 | Red | 1 |
| B | B-2 | Orange | 6 |
| B | A-2 | Yellow | 5 |
| COM-A/COM | B-3 | Green | 3 |
| COM-B/- | A-3 | Blue | 4 |
| Shield | | | |
| Vcc | B-4 | Brown | 12 |
| GND | A-4 | Black | 13 |
| A | B-5 | Red | 7 |
| A | A-5 | Black | 6 |
| B | B-6 | Orange | 9 |
| B | A-6 | Black | 8 |
| | | | 3 |

| Signal | Connector B terminal no. | Cable color | Connector D terminal no. |
|------------|--------------------------|-------------|--------------------------|
| Lock (+) | B-1 | Red | 4 |
| Lock (-) | A-1 | Black | 5 |
| Sensor (+) | B-3 | Brown | 1 |
| Sensor (-) | A-3 | Blue | 2 |

Safety Instructions

These safety instructions are intended to prevent hazardous situations and/or equipment damage. These instructions indicate the level of potential hazard with the labels of “**Caution**,” “**Warning**” or “**Danger**.” They are all important notes for safety and must be followed in addition to International Standards (ISO/IEC)*1), and other safety regulations.

 **Caution:** **Caution** indicates a hazard with a low level of risk which, if not avoided, could result in minor or moderate injury.

 **Warning:** **Warning** indicates a hazard with a medium level of risk which, if not avoided, could result in death or serious injury.

 **Danger:** **Danger** indicates a hazard with a high level of risk which, if not avoided, will result in death or serious injury.

*1) ISO 4414: Pneumatic fluid power – General rules relating to systems.
ISO 4413: Hydraulic fluid power – General rules relating to systems.
IEC 60204-1: Safety of machinery – Electrical equipment of machines.
(Part 1: General requirements)
ISO 10218-1: Manipulating industrial robots – Safety.
etc.

Warning

1. The compatibility of the product is the responsibility of the person who designs the equipment or decides its specifications.

Since the product specified here is used under various operating conditions, its compatibility with specific equipment must be decided by the person who designs the equipment or decides its specifications based on necessary analysis and test results. The expected performance and safety assurance of the equipment will be the responsibility of the person who has determined its compatibility with the product. This person should also continuously review all specifications of the product referring to its latest catalog information, with a view to giving due consideration to any possibility of equipment failure when configuring the equipment.

2. Only personnel with appropriate training should operate machinery and equipment.

The product specified here may become unsafe if handled incorrectly. The assembly, operation and maintenance of machines or equipment including our products must be performed by an operator who is appropriately trained and experienced.

3. Do not service or attempt to remove product and machinery/equipment until safety is confirmed.

1. The inspection and maintenance of machinery/equipment should only be performed after measures to prevent falling or runaway of the driven objects have been confirmed.
2. When the product is to be removed, confirm that the safety measures as mentioned above are implemented and the power from any appropriate source is cut, and read and understand the specific product precautions of all relevant products carefully.
3. Before machinery/equipment is restarted, take measures to prevent unexpected operation and malfunction.

4. Contact SMC beforehand and take special consideration of safety measures if the product is to be used in any of the following conditions.

1. Conditions and environments outside of the given specifications, or use outdoors or in a place exposed to direct sunlight.
2. Installation on equipment in conjunction with atomic energy, railways, air navigation, space, shipping, vehicles, military, medical treatment, combustion and recreation, or equipment in contact with food and beverages, emergency stop circuits, clutch and brake circuits in press applications, safety equipment or other applications unsuitable for the standard specifications described in the product catalog.
3. An application which could have negative effects on people, property, or animals requiring special safety analysis.
4. Use in an interlock circuit, which requires the provision of double interlock for possible failure by using a mechanical protective function, and periodical checks to confirm proper operation.

Caution

1. The product is provided for use in manufacturing industries.

The product herein described is basically provided for peaceful use in manufacturing industries.
If considering using the product in other industries, consult SMC beforehand and exchange specifications or a contract if necessary.
If anything is unclear, contact your nearest sales branch.

Limited warranty and Disclaimer/ Compliance Requirements

The product used is subject to the following “Limited warranty and Disclaimer” and “Compliance Requirements”.

Read and accept them before using the product.

Limited warranty and Disclaimer

1. The warranty period of the product is 1 year in service or 1.5 years after the product is delivered, whichever is first.*2)
Also, the product may have specified durability, running distance or replacement parts. Please consult your nearest sales branch.
2. For any failure or damage reported within the warranty period which is clearly our responsibility, a replacement product or necessary parts will be provided.
This limited warranty applies only to our product independently, and not to any other damage incurred due to the failure of the product.
3. Prior to using SMC products, please read and understand the warranty terms and disclaimers noted in the specified catalog for the particular products.

*2) Vacuum pads are excluded from this 1 year warranty.

A vacuum pad is a consumable part, so it is warranted for a year after it is delivered.
Also, even within the warranty period, the wear of a product due to the use of the vacuum pad or failure due to the deterioration of rubber material are not covered by the limited warranty.

Compliance Requirements

1. The use of SMC products with production equipment for the manufacture of weapons of mass destruction (WMD) or any other weapon is strictly prohibited.
2. The exports of SMC products or technology from one country to another are governed by the relevant security laws and regulations of the countries involved in the transaction. Prior to the shipment of a SMC product to another country, assure that all local rules governing that export are known and followed.

Caution

SMC products are not intended for use as instruments for legal metrology.

Measurement instruments that SMC manufactures or sells have not been qualified by type approval tests relevant to the metrology (measurement) laws of each country. Therefore, SMC products cannot be used for business or certification ordained by the metrology (measurement) laws of each country.

Safety Instructions

Be sure to read the “Handling Precautions for SMC Products” (M-E03-3) and “Operation Manual” before use.