



# Vacuum Gripper Unit for Collaborative Robots

Compliant with the TM Series  
OMRON Corporation collaborative robot  
and the TM Series TECHMAN ROBOT Inc.  
collaborative robot

## Plug and Play

configuration for immediate use

**TMComponent** Easy programming

**TMPlug&Play**  
CERTIFIED



# ZXP7□41-X1



More information  
can be viewed here.

P-E20-29

# Plug and Play

## Vacuum Gripper Unit

for Collaborative Robots

OMRON Corporation and TECHMAN ROBOT Inc.

TM5, TM12, and TM14 compliant

Operate by simply connecting 1 air supply tube and an electrical wiring M8 connector.

- Integrated vacuum ejector, air supply/release valve, pressure sensor, and cups
- Standards: Conforming to ISO 9409-1-50-4-M6
- TMComponent (Refer to page 5.)



Robot mounting flange  
(Conforming to ISO 9409-1-50-4-M6)

Parallel pin

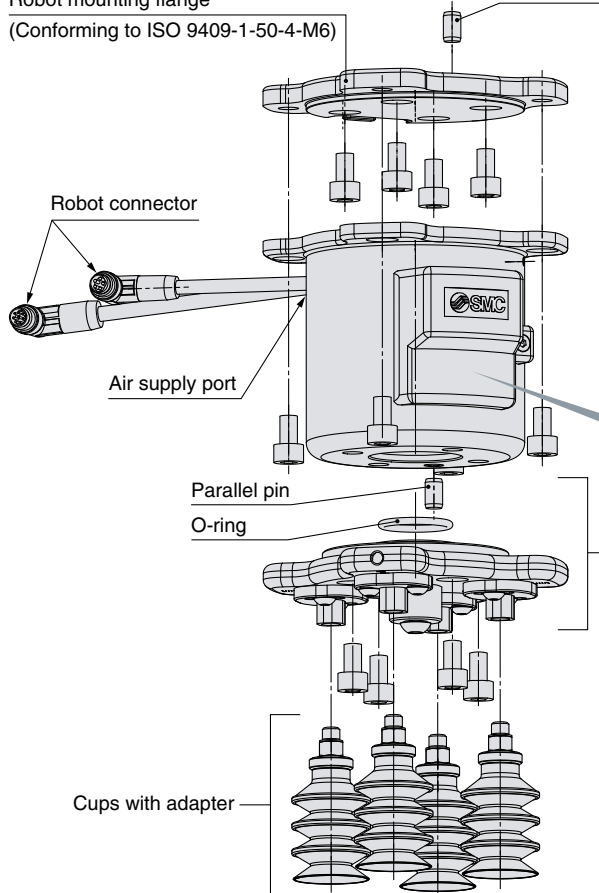

### Specifications

|                 | Standards                                     | Conforming to ISO 9409-1-50-4-M6 |
|-----------------|---|----------------------------------|
| Common          | Applicable fluid                              | Air                              |
|                 | Operating temperature range [°C]              | 5 to 50                          |
|                 | Weight [g] <sup>*3</sup>                      | 810 (597)                        |
|                 | Max. work load [kg] <sup>*4</sup>             | 7                                |
|                 | Air pressure supply (P) port                  | One-touch fitting (ø6)           |
|                 | Power supply voltage [V]                      | 24 VDC ±10%                      |
| Vacuum ejector  | Max. vacuum pressure [kPa] <sup>*5</sup>      | -84                              |
|                 | Suction flow rate [L/min (ANR)] <sup>*5</sup> | 17                               |
|                 | Air consumption [L/min (ANR)] <sup>*5</sup>   | 57                               |
|                 | Supply pressure range [MPa]                   | 0.3 to 0.55                      |
|                 | Standard supply pressure [MPa] <sup>*6</sup>  | 0.5                              |
| Pressure sensor | Rated pressure range [kPa]                    | 0 to -101                        |
|                 | Accuracy (Ambient temperature at 25°C)        | ±2% F.S.                         |
|                 | Linearity                                     | ±0.4% F.S.                       |
|                 | Repeatability                                 | ±0.2% F.S.                       |

■ Included parts: Robot mounting flange, Parallel pin, Mounting bolt, Cups with adapter\*1, Plug\*2, Piping tube (ø6)

- \*1 Included only with cups
- \*2 Included only for the ZXP7A
- \*3 The weight in brackets refers to the weight of the product without a cup mounting flange. Add the weight of the suction cups with adapter for the weight with cups. (Refer to the "Suction Cup Part Numbers and Weight" on page 3.)
- \*4 May be restricted depending on the cup diameter, mounting orientation, or workpiece. Please use within the max. work load. Suction and transfer exceeding the max. work load may result in reduced vacuum pressure due to air leakage.
- \*5 Values are at the standard supply pressure and based on SMC's measurement standards. They depend on atmospheric pressure (weather, altitude, etc.) and the measurement method.
- \*6 This value indicates the pressure right before the air pressure supply (P) port when vacuum is generated. The pressure right before the P port of the vacuum gripper unit when vacuum is generated may fall below 0.5 MPa due to the air supply capacity, piping size, and the amount of air being consumed by other devices being operated simultaneously.

### Details of internal parts

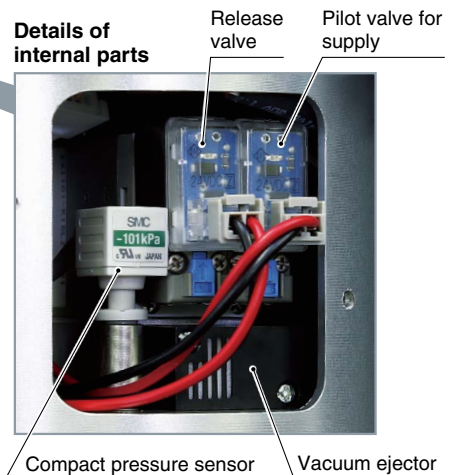

# Adsorption Unit Variations

The number of cups can be changed.



1 cup

2 cups

4 cups

The cup type can be changed. (For details on selectable cups, refer to "How to Order.")



Flat (ø8), Silicone rubber

Bellows (ø20), NBR

Thin flat (ø16), NBR

Flat (ø32), Silicone rubber

Flat (ø32), Urethane rubber



ø32, 2.5-stage, Silicone rubber

ø25, 5.5-stage, Silicone rubber

ø25, 5.5-stage, Silicone rubber With vacuum saving valve



Vacuum saving valve  
ZP2V Series  
(To be ordered separately)  
Applicable part no.: ZP2V-B6-05

\* The silicone material is compliant with the FDA (U.S. Food and Drug Administration) regulation 21CFR§177.

■ The cup pitch can be changed.

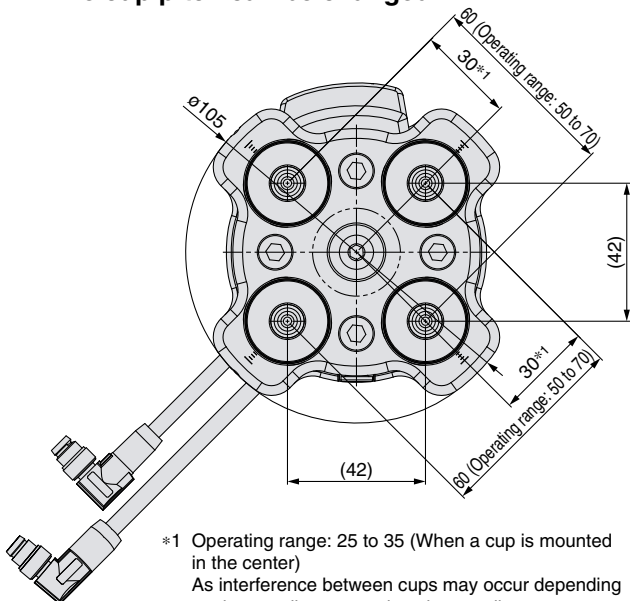

■ The cup with flange can be used separately

(if using an external vacuum source).



\*2 When using a cup with flange, be sure to order a One-touch fitting for vacuum pressure supply (part number: KQ2L08-01NS) and a vacuum port plug (part number: M-5P) separately.

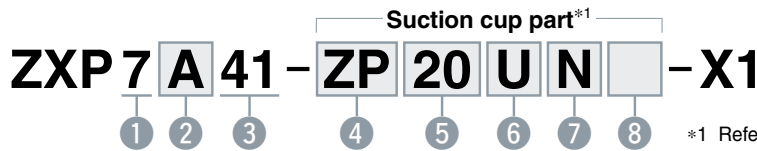

\*1 Refer to the table below for the applicable cups.

**1 Unit size**

| Symbol | Size  |
|--------|-------|
| 7      | 75 mm |

**2 Cup flange shape**

| Symbol | Shape            |
|--------|------------------|
| A      | 42 mm x 42 mm    |
| N      | Without flange*2 |

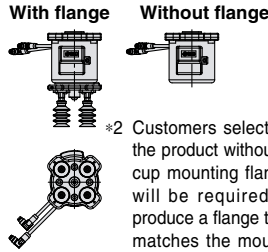

**3 Compatible manufacturer**

| Symbol | Robot manufacturer                 |
|--------|------------------------------------|
| 41     | OMRON,<br>TECHMAN: TM5, TM12, TM14 |

**4 Cup series**

| Symbol | Series                                     |
|--------|--|
| ZP     | Basic                                      |
| ZP3P   | Bellows type for film packaging workpieces |
| Nil    | Without cup                                |

**5 Cup diameter**

| Symbol | Cup diameter | Symbol | Cup diameter |
|--------|--------------|--------|--------------|
| 08     | ø8           | 25     | ø25          |
| 10     | ø10          | B25    | ø25          |
| 13     | ø13          | B30    | ø30          |
| 16     | ø16          | 32     | ø32          |
| 20     | ø20          | Nil    | Without cup  |

**6 Cup form**

| Symbol | Type               |
|--------|--------------------|
| U      | Flat               |
| C      | Flat with rib      |
| B      | Bellows            |
| UT     | Thin flat          |
| J      | Multistage bellows |
| JT2    | 2.5-stage bellows  |
| JT5    | 5.5-stage bellows  |
| Nil    | Without cup        |

**7 Cup material**

| Symbol | Material                  |
|--------|---------------------------|
| N      | NBR                       |
| S      | Silicone rubber (White)*3 |
| U      | Urethane rubber           |
| F      | FKM                       |
| SF     | Silicone rubber (Blue)*3  |
| Nil    | Without cup               |

\*3 The silicone material is compliant with the FDA (U.S. Food and Drug Administration) regulation 21CFR§177.

**8 Attachment\*4**

| Symbol | Attachment              |
|--------|-------------------------|
| Nil    | With (guide) attachment |
| M      | With mesh attachment    |

\*4 Only applicable to the cup form "JT"

\*1

**Suction Cup Part Numbers and Weight**



**Applicable cups**

| 4          | 5            | 6        | 7            | 8          |
|------------|--------------|----------|--------------|------------|
| Cup series | Cup diameter | Cup form | Cup material | Attachment |
| ZP         | 08           | U        | □            |            |
| ZP         | 08           | B        | □            |            |
| ZP         | 10           | UT       | □            |            |
| ZP         | 13           | UT       | □            |            |
| ZP         | 16           | UT       | □            |            |
| ZP         | 10           | U        | □            |            |
| ZP         | 13           | U        | □            |            |
| ZP         | 16           | U        | □            |            |
| ZP         | 20           | U        | □            |            |
| ZP         | 25           | U        | □            |            |
| ZP         | 32           | U        | □            |            |
| ZP         | 10           | C        | □            |            |
| ZP         | 13           | C        | □            |            |
| ZP         | 16           | C        | □            |            |
| ZP         | 20           | C        | □            |            |
| ZP         | 25           | C        | □            |            |
| ZP         | 32           | C        | □            |            |
| ZP         | 10           | B        | □            |            |
| ZP         | 13           | B        | □            |            |
| ZP         | 16           | B        | □            |            |
| ZP         | 20           | B        | □            |            |
| ZP         | 25           | B        | □            |            |
| ZP         | 32           | B        | □            |            |
| ZP         | 20           | UT       | □            |            |
| ZP         | 16           | J        | □            |            |
| ZP         | B25          | J        | □            |            |
| ZP         | B30          | J        | □            |            |
| ZP3P       | 20           | JT2      | SF           |            |
| ZP3P       | 20           | JT2      | SF           | M          |
| ZP3P       | 32           | JT2      | SF           |            |
| ZP3P       | 32           | JT2      | SF           | M          |
| ZP3P       | 20           | JT5      | SF           |            |
| ZP3P       | 25           | JT5      | SF           |            |
| ZP3P       | 32           | JT5      | SF           |            |

**Cup part numbers**

| Part no.             | Cup with adapter |                    |                 |            | Adapter unit<br>Vacuum inlet:<br>(Male thread M6 x 1) | Cup unit   |                 |
|----------------------|------------------|--------------------|-----------------|------------|---|------------|-----------------|
|                      | N<br>(NBR)       | S/SF<br>(Silicone) | U<br>(Urethane) | F<br>(FKM) |   |            |                 |
| ZPT08U□-A6           | 4                | 4                  | 4               | 4          | ZPT1-A6   | ZP08U□     |                 |
| ZPT08B□-A6           | 4                | 4                  | 4               | 4          |   | ZP08B□     |                 |
| ZPT10UT□-A6          | 4                | 4                  | 4               | 4          |   | ZP10UT□    |                 |
| ZPT13UT□-A6          | 4                | 4                  | 4               | 4          |   | ZP13UT□    |                 |
| ZPT16UT□-A6          | 4                | 4                  | 4               | 4          | ZP16UT□   |            |                 |
| ZPG10U□-7A-X2        | 7                | 7                  | 7               | 7          | ZPT2-7A-X2  | ZP10U□     |                 |
| ZPG13U□-7A-X2        | 7                | 7                  | 7               | 8          |   | ZP13U□     |                 |
| ZPG16U□-7A-X2        | 7                | 7                  | 7               | 8          |   | ZP16U□     |                 |
| ZPG20U□-7A-X2        | 9                | 10                 | 10              | 10         |   | ZP20U□     |                 |
| ZPG25U□-7A-X2        | 10               | 10                 | 10              | 11         | ZPT3-7A-X2  | ZP25U□     |                 |
| ZPG32U□-7A-X2        | 10               | 11                 | 11              | 12         |   | ZP32U□     |                 |
| ZPG10C□-7A-X2        | 7                | 7                  | 7               | 7          |   | ZP10C□     |                 |
| ZPG13C□-7A-X2        | 7                | 7                  | 7               | 7          |   | ZP13C□     |                 |
| ZPG16C□-7A-X2        | 7                | 7                  | 7               | 8          | ZPT2-7A-X2  | ZP16C□     |                 |
| ZPG20C□-7A-X2        | 9                | 10                 | 10              | 11         |   | ZP20C□     |                 |
| ZPG25C□-7A-X2        | 10               | 10                 | 10              | 11         |   | ZP25C□     |                 |
| ZPG32C□-7A-X2        | 10               | 11                 | 11              | 12         |   | ZP32C□     |                 |
| ZPG10B□-7A-X2        | 7                | 7                  | 7               | 8          | ZPT3-7A-X2  | ZP10B□     |                 |
| ZPG13B□-7A-X2        | 7                | 8                  | 8               | 8          |   | ZP13B□     |                 |
| ZPG16B□-7A-X2        | 8                | 8                  | 8               | 9          |   | ZP16B□     |                 |
| ZPG20B□-7A-X2        | 11               | 11                 | 11              | 13         |   | ZP20B□     |                 |
| ZPG25B□-7A-X2        | 11               | 12                 | 12              | 14         | ZPT2-7A-X2  | ZP25B□     |                 |
| ZPG32B□-7A-X2        | 14               | 15                 | 15              | 18         |   | ZP32B□     |                 |
| ZPG20UT□-7A-X2       | 4                | 4                  | 4               | 4          |   | ZP20UT□    |                 |
| ZPG16J□-7A-X2        | 8                | 8                  | 8               | 9          |   | ZP2-16J□   |                 |
| ZPGB25J□-7A-X2       | 14               | 15                 | 15              | 18         | ZPT1-A6   | ZP2-B25J□  |                 |
| ZPGB30J□-7A-X2       | 18               | 19                 | 19              | 25         |   | ZP2-B30J□  |                 |
| ZP3PG20JT2SF-7A-X2   | —                | 21                 | —               | —          |   | ZPT2-7A-X2 | ZP3P-20JT2SF-WM |
| ZP3PG20JT2SF-M-7A-X2 | —                | 21                 | —               | —          |   |            | ZP3P-20JT2SF-WM |
| ZP3PG32JT2SF-7A-X2   | —                | 48                 | —               | —          | ZPT3-7A-X2  |            | ZP3P-32JT2SF-WM |
| ZP3PG32JT2SF-M-7A-X2 | —                | 48                 | —               | —          |   |            | ZP3P-32JT2SF-WM |
| ZP3PG20JT5SF-7A-X2   | —                | 23                 | —               | —          |   | ZPT1-A6    | ZP3P-20JT5SF-WG |
| ZP3PG25JT5SF-7A-X2   | —                | 25                 | —               | —          |   |            | ZP3P-25JT5SF-WG |
| ZP3PG32JT5SF-7A-X2   | —                | 54                 | —               | —          | ZPT2-7A-X2  |            | ZP3P-32JT5SF-WG |
| ZP3PG32JT5SF-M-7A-X2 | —                | 54                 | —               | —          |   |            | ZP3P-32JT5SF-WG |

\* Refer to the **Web Catalog** for details on suction cups.

Input the material symbol ("N," "S," "U," or "F") into the □ in the part number.



## Model Selection

### Exhaust Characteristics\*1

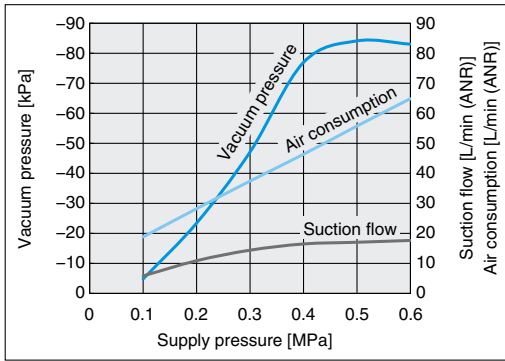

### Flow Rate Characteristics

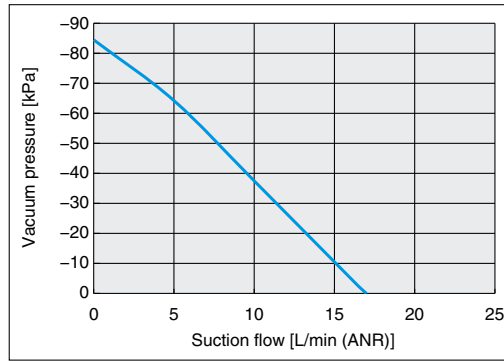

\*1 The exhaust characteristics are different when the vacuum-saving valve (ZP2V-B6-05) is mounted.  
For details, refer to "8.3 Suction cup precautions" in the operation manual.

## Dimensions

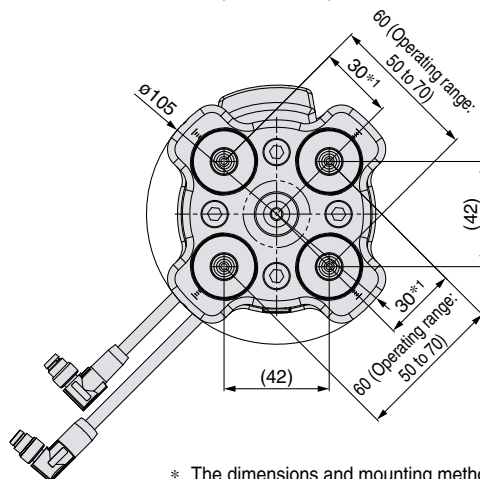
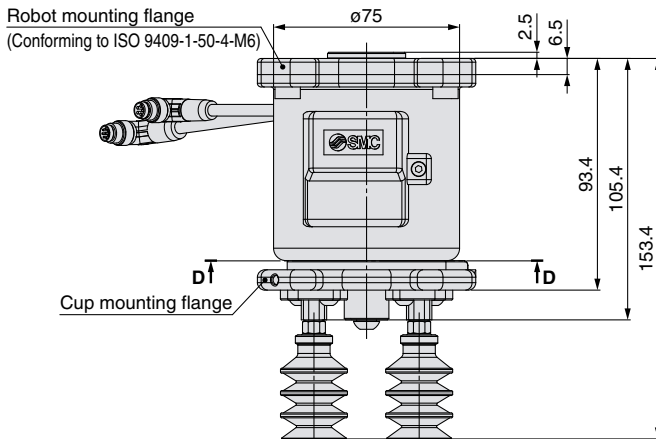
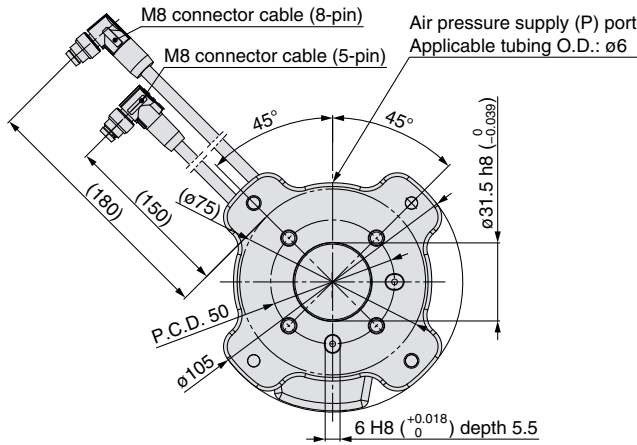

\*1 Operating range: 25 to 35 (When a cup is mounted in the center)  
As interference between cups may occur depending on the cup diameter, select the cup diameter according to the pitch to be used.

### Circuit diagram

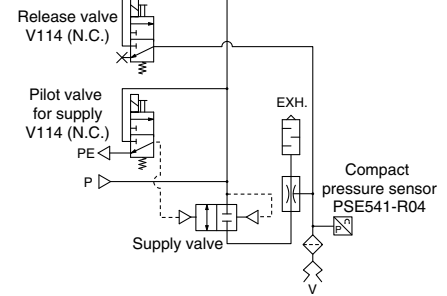

### Cup mounting flange

Replacement part number: **ZXP7-PFL1-A-X1**

(Refer to the figure below for items. Quantities are shown in the parentheses.)

Plug (For vacuum pressure supply port) (1)

Parallel pin (1)

O-ring (1)

Plug (For vacuum pressure supply port) (1)

Plug (4)

(For cup with adapter)

Cup flange (1)

Hexagon socket head cap screw (4)

### Without cup mounting flange

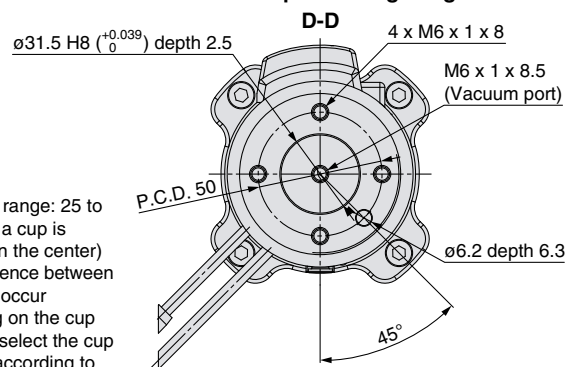

\* The vacuum port doesn't come with mesh.

\* The dimensions and mounting method described in this drawing (example) are for the following part number: ZXP7A41-ZPB25JS-X1

# TMComponent

More information on the TMComponent software can be viewed here.



## Easy programming

Using the certified software TMComponent of OMRON Corporation and TECHMAN ROBOT Inc., various operations and sensor signals can be easily programmed by using a control box equipped with the dedicated software tool “TMflow” or by using graphical flowcharts on a Windows computer.

You can easily install the software by inserting a USB with the TMComponent software package into a control box or Windows computer.

\* Please download the TMComponent software package from the SMC website, and save it to a USB memory.

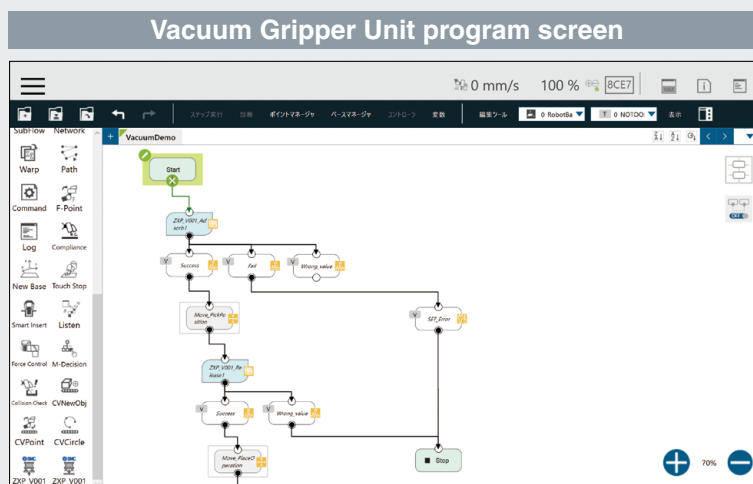
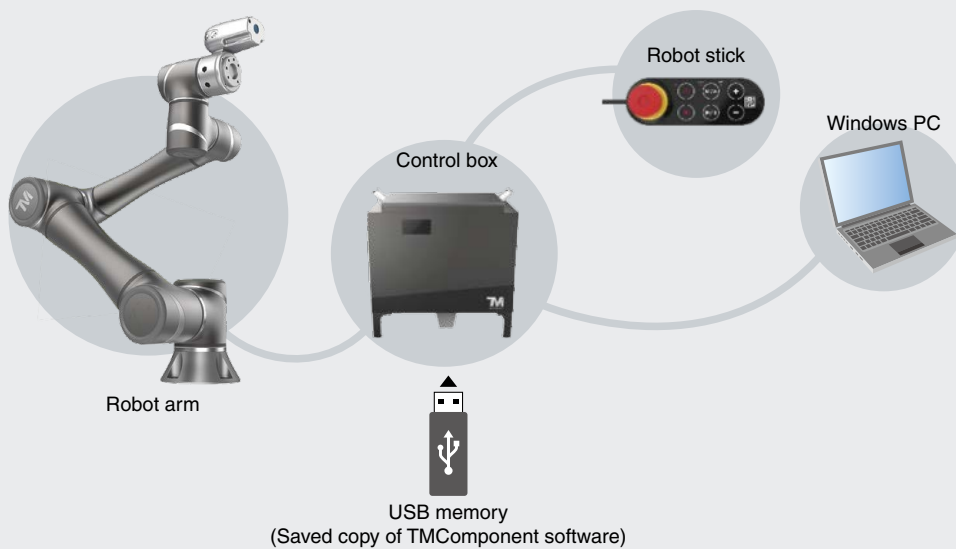



# ZXP7□41-X1

## Specific Product Precautions

Be sure to read this before handling the products. For safety instructions and vacuum equipment precautions, refer to the “Handling Precautions for SMC Products” and the “Operation Manual” on the SMC website: <https://www.smcworld.com>

### Handling

#### Caution

1. Strictly observe the precautions on vacuum equipment and safety when using the product. Additionally, select a cup size and material suitable to both the workpiece to be adsorbed and the atmosphere. Take safety measures so that any accident, such as the dropping of a workpiece, does not occur during adsorption transfer. For details, refer to the Web Catalog.
2. Use the product within the specification range. Use exceeding the compressed air pressure or voltage may result in serious damage due to reduced product performance.
3. Exhaust air is released from the opening in the product. Therefore, this exhaust air opening must not be blocked or restricted.

### Mounting

#### Caution

1. For details on the mounting method, refer to the Operation Manual.
2. Tighten to the specified tightening torque. If the tightening torque is exceeded, the body and the mounting screws may break. However, insufficient torque may cause displacement of the body and loosening of the mounting screws.
3. Do not drop, strike, or apply excessive impact to this product.  
Doing so may result in damage to the internal parts of the body, solenoid valve, or pressure sensor. In some cases, this damage may result in a malfunction.
4. Hold the body when handling the product. Do not pull excessively on the M8 connector cable or pinch the cable when lifting the body. Failure to do so may result in damage to the solenoid valve or pressure sensor. In some cases, this damage may result in a failure or malfunction.
5. The bolts may loosen due to the operating conditions and environment. Be sure to conduct maintenance such as tightening the bolts periodically.

### Wiring

#### Caution

1. Avoid repeatedly bending or stretching the M8 connector cable as well as applying force to it.
2. Do not wire while energizing the product. Doing so may result in damage to the internal parts of the solenoid valve or pressure sensor. In some cases, this damage may result in a malfunction.
3. Do not disassemble the M8 connector cable or make any modifications, including additional machining. Doing so may cause human injury and/or an accident.

### Piping

#### Caution

##### 1. Flushing of the inside of the pipes

Before piping is connected, it should be thoroughly blown out with air (flushing) or washed to remove chips, cutting oil, and other debris from inside the pipe.

##### 2. Tube attachment

- Take a tube having no flaws on its periphery and cut it off at a right angle. When cutting the tube, use tube cutters TK-1, 2, 3, 5, or 6. Do not use pliers, nippers, scissors, etc. If cutting is done with tools other than tube cutters, the tube may be cut diagonally or become flattened, etc., making a secure installation impossible, and causing problems such as the tube pulling out after installation or air leakage. Allow some extra length in the tube.
- Grasp the tube and push it in slowly, inserting it securely all the way into the fitting.
- After inserting the tube, pull on it lightly to confirm that it will not come out. If it is not installed securely all the way into the fitting, this can cause problems such as air leakage or the tube pulling out.

##### 3. Tube detachment

- Push in the release button sufficiently, pushing its collar equally around the circumference.
- Pull out the tube while holding down the release button so that it does not come out. If the release button is not pressed down sufficiently, there will be increased bite on the tube and it will become more difficult to pull it out.
- When the removed tube is to be used again, cut off the portion which has been chewed before reusing it. If the chewed portion of the tube is used as is, this can cause trouble such as air leakage or difficulty in removing the tube.

##### 4. Other Tube Brands

When using other than SMC brand tube, confirm that the following specifications are satisfied with respect to the tube outside diameter tolerance.

- Nylon tube within  $\pm 0.1$  mm
- Soft nylon tube within  $\pm 0.1$  mm
- Polyurethane tube within  $\pm 0.15$  mm, within  $-0.2$  mm

Do not use tube which do not meet these outside diameter tolerances. It may not be possible to connect them, or they may cause other trouble, such as air leakage or the tube pulling out after connection.

##### 5. Piping

- Do not apply unnecessary forces, such as twisting, pulling, moment loads, vibration, impact, etc., on fittings or tubing. This will cause damage to fittings and will crush, burst, or release tubing.
- Do not lift the product by the piping after the tube is connected. Doing so may result in damage to the One-touch tube fitting. For details, refer to the “Handling Precautions for SMC Products” on the SMC website: <https://www.smcworld.com>



## Vacuum Gripper Unit for Collaborative Robots



**⚠ Safety Instructions** Be sure to read the "Handling Precautions for SMC Products" (M-E03-3) and "Operation Manual" before use.