

Particle Generation Characteristics

11-LEJS Series ▶ p. 657

Particle Generation Measuring Method

The particle generation data for the 11-LEJS series are measured in the following test method.

Test Method (Example)

Operate the specimen that is placed in an ISO Class 5 equivalent clean bench, and measure the changes of the particle concentration over time until the number of cycles reaches the specified point.

Measuring Conditions

Measuring instrument	Description	Laser dust monitor (Automatic particle counter using the light scattering method)
	Minimum measurable particle diameter	0.1 μm
	Suction flow rate	28.3 L/min (ANR)
Setting conditions	Sampling time	5 min
	Interval time	55 min
	Sampling air flow	141.5 L (ANR)

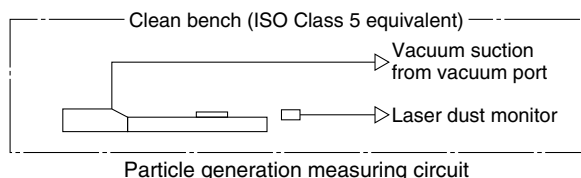

Test Conditions

Size	Speed [mm/s]	Model	Workpiece mass [kg]	Acceleration [mm/s ²]	Duty ratio [%]
40	1200	11-LEJS40□A-200	4	13000	100
	600	11-LEJS40□B-200		10000	
63	1200	11-LEJS63□A-300		13000	
	600	11-LEJS63□B-300		10000	

* Mounting position: Horizontal

Evaluation Method

To obtain the measured values of particle concentration, the accumulated value*¹ of particles captured every 5 minutes, by the laser dust monitor, is converted into the particle concentration in every 1 m³.

When determining particle generation grades, the 95% upper confidence limit of the average particle concentration (average value), when each specimen is operated at a specified number of cycles*² is considered.

The plots in the graphs indicate the 95% upper confidence limit of the average particle concentration of particles with a diameter within the horizontal axis range.

*¹ Sampling air flow rate: Number of particles contained in 141.5 L (ANR) of air

*² Actuator: 1 million cycles

* The particle generation characteristics (page 656) provide a guide for selection but is not guaranteed.

Particle Generation Characteristics

11-LEJS40/Ball Screw Drive

Speed 600 mm/s

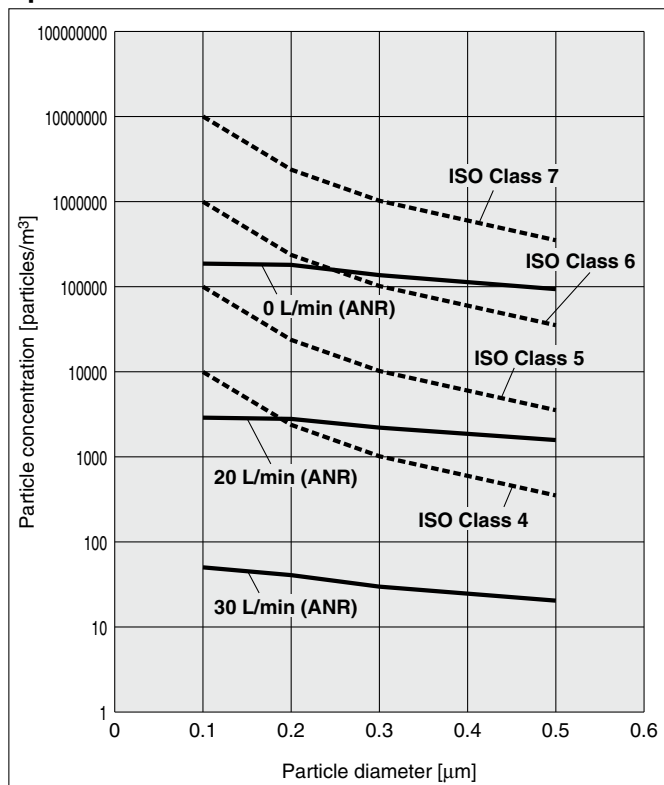

Speed 1200 mm/s

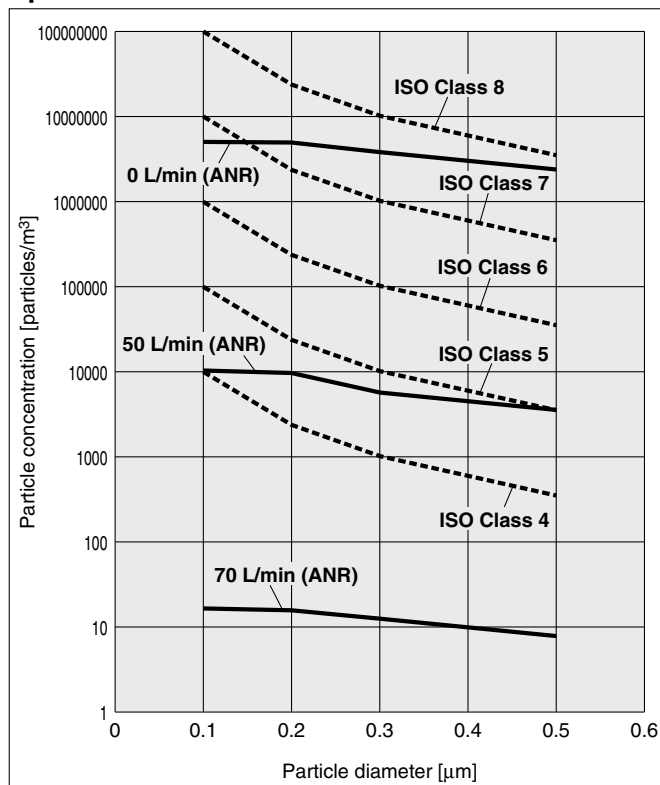

11-LEJS63/Ball Screw Drive

Speed 600 mm/s

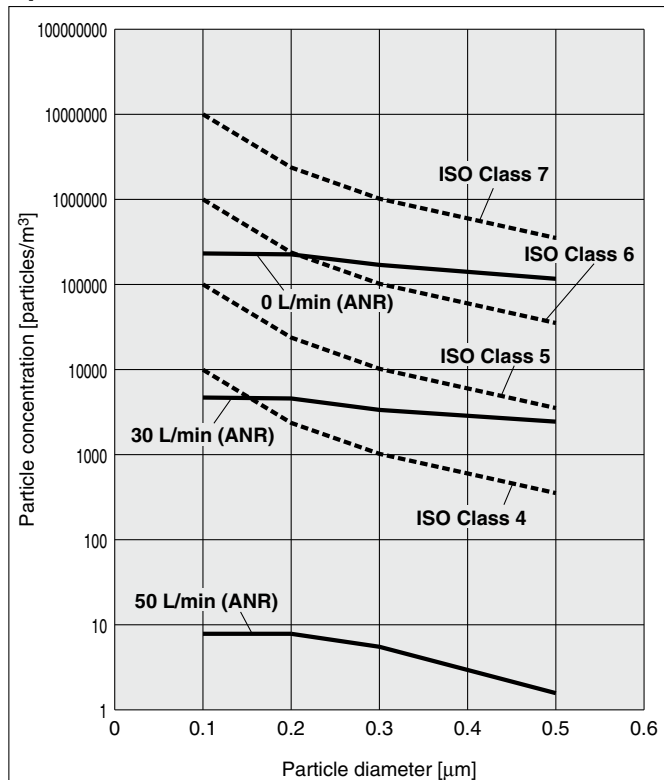

Speed 1200 mm/s

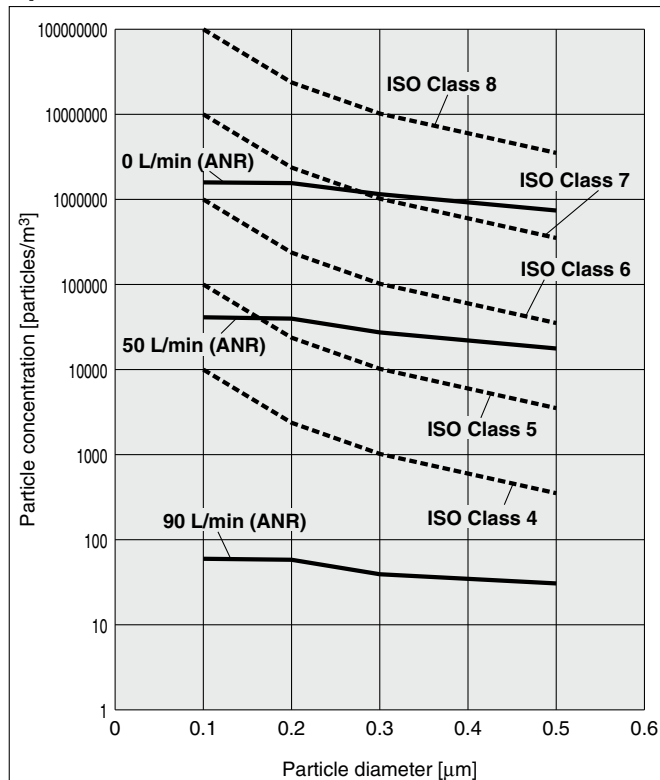

- LEFS
- LEFB
- LEJS
- LEJB
- LEL
- LEM
- LEYP
- LEYS
- LESH
- LEPY
- LEPS
- LER
- LEH
- LEH-X5
- LEY-X5
- 11-LEFS
- 11-LEJS
- 25A-
- LEC
- JXC
- LECS
- LECS-T
- LECY
- Motorless
- LAT3

Electric Actuator/High Rigidity Slider Type Ball Screw Drive

Clean Room Specification



11-LEJS Series LEJS40, 63

Refer to page 175 for model selection and page 655 for particle generation characteristics.



LECY □ Series ▶ p. 659

How to Order

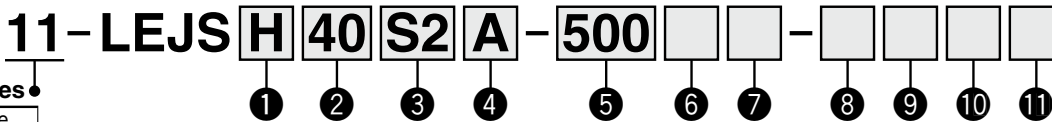

Clean series ●

11	Vacuum type
----	-------------

① Accuracy

Nil	Basic type
H	High-precision type

② Size

40
63

④ Lead [mm]

Symbol	LEJS40	LEJS63
A	16	20
B	8	10

⑤ Stroke [mm]*3

200
to
1500

*3 Refer to the applicable stroke table for details.

⑥ Motor option

Nil	Without option
B	With lock

⑦ Vacuum port*5

Nil	Left
R	Right
D	Both left and right

*5 Select "D" for the vacuum port for suction of 50 L/min (ANR) or more.

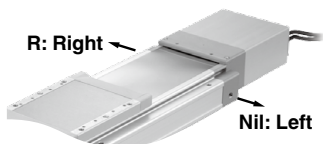

③ Motor type

Symbol	Type	Output [W]	Actuator size	Compatible drivers	UL-compliant
S2*1	AC servo motor (Incremental encoder)	100	40	LECSA□-S1	●
S3	AC servo motor (Incremental encoder)	200	63	LECSA□-S3	●
S6*1	AC servo motor (Absolute encoder)	100	40	LECSB□-S5 LECS□-S5 LECSC□-S5	—
S7	AC servo motor (Absolute encoder)	200	63	LECSB□-S7 LECS□-S7 LECSC□-S7	—
T6*2	AC servo motor (Absolute encoder)	100	40	LECSB2-T5 LECS□2-T5 LECSN2-T5-□	—
T7				200	63

*1 For motor type S2 and S6, the compatible driver part number suffixes are S1 and S5 respectively.

*2 For motor type T6, the compatible driver part number is LECS□2-T5.

⑧ Cable type*6, *7

Nil	Without cable
S	Standard cable
R	Robotic cable (Flexible cable)

*6 The motor and encoder cables are included. (The lock cable is also included when the motor with lock option is selected.)

*7 Standard cable entry direction is "(A) Axis side."

⑨ Cable length [m]*6, *8

Nil	Without cable
2	2 m
5	5 m
A	10 m

*8 The length of the motor, encoder, and lock cables are the same.

⑩ Driver type*5

	Compatible drivers	Power supply voltage [V]	UL-compliant
Nil	Without driver	—	—
A1	LECSA1-S□	100 to 120	●
A2	LECSA2-S□	200 to 230	●
B1	LECSB1-S□	100 to 120	—
B2	LECSB2-S□	200 to 230	—
	LECSB2-T□	200 to 240	●
C1	LECS□1-S□	100 to 120	—
C2	LECS□2-S□	200 to 230	—
	LECS□2-T□	200 to 230	●
S1	LECS□1-S□	100 to 120	—
S2	LECS□2-S□	200 to 230	—
	LECS□2-T□	200 to 240	●
N2	LECSN2-T□	200 to 240	●
92	LECSN2-T□-9	200 to 240	—
E2	LECSN2-T□-E	200 to 240	—
P2	LECSN2-T□-P	200 to 240	—

*5 When a driver type is selected, a cable is included. Select the cable type and cable length. Example) S2S2: Standard cable (2 m) + Driver (LECS□2)

S2: Standard cable (2 m)

Nil: Without cable and driver

⑪ I/O cable length [m]*9

Nil	Without cable
H	Without cable (Connector only)
1	1.5

*9 When "Without driver" is selected for driver type, only "Nil: Without cable" can be selected. Refer to page 797 if I/O cable is required. (Options are shown on page 797.)

Applicable Stroke Table*4

Model	Stroke [mm]										
	200	300	400	500	600	700	800	900	1000	1200	1500
11-LEJS40	●	●	●	●	●	●	●	●	●	●	—
11-LEJS63	—	●	●	●	●	●	●	●	●	●	●

*4 Please consult with SMC for non-standard strokes as they are produced as special orders.

Compatible Drivers

For auto switches, refer to pages 210 to 213.

Driver type	Pulse input type/ Positioning type	Pulse input type	CC-Link direct input type	SSCNET III type	Pulse input type	CC-Link direct input type	SSCNET III/H type	Network card type
Series	LECSA	LECSB	LECS□	LECS□	LECSB-T	LECS□-T	LECS□-T	LECSN-T
Number of point tables*10	Up to 7	—	Up to 255	—	Up to 255	Up to 255 (2 stations occupied)	—	Up to 255
Pulse input	○	○	—	—	○	—	—	—
Applicable network	—	—	CC-Link	SSCNET III	—	CC-Link	SSCNET III/H	PROFINET EtherCAT [®] EtherNet/IP [™]
Control encoder	Incremental 17-bit encoder	Absolute 18-bit encoder	Absolute 18-bit encoder	Absolute 18-bit encoder	Absolute 22-bit encoder	Absolute 18-bit encoder	Absolute 22-bit encoder	Absolute 22-bit encoder
Communication function	USB communication	USB communication, RS422 communication	—	USB communication	USB communication, RS422 communication	—	USB communication	USB communication
Power supply voltage [V]	100 to 120 VAC (50/60 Hz), 200 to 230 VAC (50/60 Hz)				200 to 240 VAC (50/60 Hz)	200 to 230 VAC (50/60 Hz)	200 to 240 VAC (50/60 Hz)	200 to 240 VAC (50/60 Hz)
Reference page	777							

*10 The LECSN-T only supports PROFINET and EtherCAT[®].

Specifications

11-LEJS40, 63 AC Servo Motor

Model		11-LEJS40S [‡] /T6		11-LEJS63S [‡] /T7			
Actuator specifications	Stroke [mm] ^{*1}	200, 300, 400, 500, 600, 700, 800 900, 1000, 1200		300, 400, 500, 600, 700, 800, 900 1000, 1200, 1500			
	Work load [kg] ^{*2}	Horizontal	30	55	45	85	
		Vertical	5	10	10	20	
	Speed ^{*3} [mm/s]	Stroke range	Up to 500	1200	600	1200	600
			501 to 600	1050	520	1200	600
			601 to 700	780	390	1200	600
			701 to 800	600	300	930	460
			801 to 900	480	240	740	370
			901 to 1000	390	190	600	300
			1001 to 1100	320	160	500	250
			1101 to 1200	270	130	420	210
			1201 to 1300	—	—	360	180
			1301 to 1400	—	—	310	150
	1401 to 1500	—	—	270	130		
	Max. acceleration/deceleration [mm/s ²]	20000 (Refer to pages 179 and 180 for limit according to work load and duty ratio.)					
Positioning repeatability [mm]	Basic type	±0.02					
	High-precision type	±0.01					
Lost motion [mm] ^{*4}	Basic type	0.1 or less					
	High-precision type	0.05 or less					
Lead [mm]	16	8	20	10			
Impact/Vibration resistance [m/s ²] ^{*5}	50/20						
Actuation type	Ball screw						
Guide type	Linear guide						
Grease	Ball screw/Linear guide portion						
Cleanliness class ^{*6}	Low particle generation grease						
Allowable external force [N]	ISO Class 4 (ISO 14644-1)						
Operating temperature range [°C]	20						
Operating humidity range [%RH]	5 to 40						
Regeneration option	90 or less (No condensation)						
Motor output [W]/Size [mm]	100□40		200□60				
Motor type	AC servo motor (100/200 VAC)						
Encoder ^{*12}	Motor type S2, S3: Incremental 17-bit encoder (Resolution: 131072 p/rev) Motor type S6, S7: Absolute 18-bit encoder (Resolution: 262144 p/rev) Motor type T6, T7: Absolute 22-bit encoder (Resolution: 4194304 p/rev) (For LECSB-T□, LECS-S-T□) Motor type T6, T7: Absolute 18-bit encoder (Resolution: 262144 p/rev) (For LECS-C-T□)						
Power consumption [W] ^{*7}	Horizontal	65	80				
	Vertical	165	235				
Standby power consumption when operating [W] ^{*8}	Horizontal	2	2				
	Vertical	10	12				
Max. instantaneous power consumption [W] ^{*9}	445		725				
Type ^{*10}	Non-magnetizing lock						
Holding force [N]	101	203	330	660			
Power consumption at 20°C [W] ^{*11}	6.3		7.9				
Rated voltage [V]	24 VDC ⁰ / _{-10%}						

*1 Please consult with SMC for non-standard strokes as they are produced as special orders.
 *2 For details, refer to the "Speed-Work Load Graph (Guide)" on page 176.
 *3 The allowable speed changes according to the stroke.
 *4 A reference value for correcting an error in reciprocal operation
 *5 Impact resistance: No malfunction occurred when the actuator was tested with a drop tester in both an axial direction and a perpendicular direction to the lead screw. (The test was performed with the actuator in the initial state.)
 Vibration resistance: No malfunction occurred in a test ranging between 45 to 2000 Hz. The test was performed in both an axial direction and a perpendicular direction to the lead screw. (The test was performed with the actuator in the initial state.)
 *6 The amount of particle generation changes according to the operating conditions and suction flow rate. Refer to the particle generation characteristics for details.

*7 The power consumption (including the driver) is for when the actuator is operating.
 *8 The standby power consumption when operating (including the driver) is for when the actuator is stopped in the set position during the operation.
 *9 The maximum instantaneous power consumption (including the driver) is for when the actuator is operating. This value can be used for the selection of the power supply.
 *10 Only when motor option "With lock" is selected
 *11 For an actuator with lock, add the power consumption for the lock.
 *12 The resolution will change depending on the driver type.
 * Sensor magnet position is located in the table center.
 For detailed dimensions, refer to the "Auto Switch Mounting Position" on page 210.
 * Do not allow collisions at either end of the table traveling distance. Additionally, when running the positioning operation, do not set within 2 mm of both ends.
 * For the manufacture of intermediate strokes, please contact SMC.
 (11-LEJS40/Manufacturable stroke range: 200 to 1200 mm, 11-LEJS63/Manufacturable stroke range: 300 to 1500 mm)

Weight

Model	11-LEJS40									
Stroke [mm]	200	300	400	500	600	700	800	900	1000	1200
Product weight [kg]	5.6	6.4	7.1	7.9	8.7	9.4	10.2	11.0	11.7	13.3
Additional weight with lock [kg]	S2: 0.2/S6: 0.3/T6: 0.2									
Model	11-LEJS63									
Stroke [mm]	300	400	500	600	700	800	900	1000	1200	1500
Product weight [kg]	11.4	12.7	13.9	15.2	16.4	17.7	18.9	20.1	22.6	26.4
Additional weight with lock [kg]	S3: 0.4/S7: 0.7/T7: 0.4									

LEFS
LEFB
LEJS
LEJB
LEL
LEM
LEY
LEYG
LES
LESH
LEPY
LEPS
LER
LEH
LEY-X5
11-LEFS
11-LEJS
25A-
LEC□
JXC□
LECS□
LECS-T□
LECY□
Motorless
LAT3

Electric Actuator/High Rigidity Slider Type Ball Screw Drive

Clean Room Specification

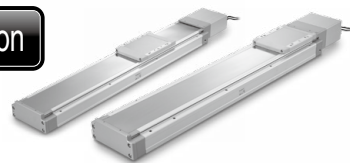

11-LEJS Series LEJS40, 63

Refer to page 186 for model selection and page 655 for particle generation characteristics.



LECS □ Series ▶ p. 657

How to Order

Dimensions are the same as those of the LECS □ series. For details, refer to page 661 and onwards.

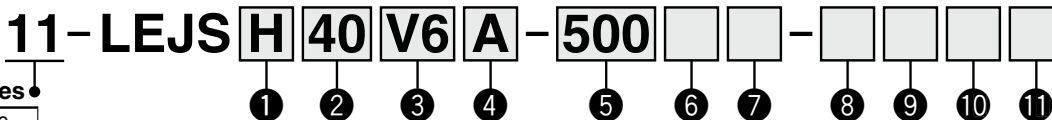

Clean series ●

11	Vacuum type
----	-------------

1 Accuracy

Nil	Basic type
H	High-precision type

2 Size

40
63

6 Motor option

Nil	Without option
B	With lock

7 Vacuum port*5

Nil	Left
R	Right
D	Both left and right

*5 Select "D" for the vacuum port for suction of 50 L/min (ANR) or more.

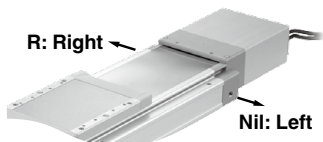

3 Motor type*1

Symbol	Type	Output [W]	Actuator size	Compatible*2 drivers
V6	AC servo motor (Absolute encoder)	100	40	LECYM2-V5 LECYU2-V5
V7	AC servo motor (Absolute encoder)	200	63	LECYM2-V7 LECYU2-V7

*1 For motor type V6, the compatible driver part number suffix is V5.

*2 For details on the driver, refer to page 801.

4 Lead [mm]

Symbol	LEJS40	LEJS63
A	16	20
B	8	10

5 Stroke [mm]*3

200
to
1500

*3 Refer to the applicable stroke table for details.

8 Cable type*6, *7, *8

Nil	Without cable
S	Standard cable
R	Robotic cable (Flexible cable)

*6 When a driver type is selected, a cable is included. Select the cable type and cable length.

Example)

S2S2: Standard cable (2 m) + Driver (LECSS2)

S2: Standard cable (2 m)

Nil: Without cable and driver

*7 The motor and encoder cables are included. (The lock cable is also included when the motor with lock option is selected.)

*8 Standard cable entry direction is "(A) Axis side."

9 Cable length [m]*6, *9

Nil	Without cable
3	3
5	5
A	10
C	20

*9 The length of the motor, encoder, and lock cables are the same.

10 Driver type*6

	Compatible drivers	Power supply voltage [V]
Nil	Without driver	—
M2	LECYM2-V□	200 to 230
U2	LECYU2-V□	200 to 230

11 I/O cable length [m]*10

Nil	Without cable
H	Without cable (Connector only)
1	1.5

*10 When "Without drive" is selected for driver type, only "Nil: Without cable" can be selected. Refer to page 797 if I/O cable is required. (Options are shown on page 797.)

Applicable Stroke Table*4

●: Standard

Model \ Stroke [mm]	200	300	400	500	600	700	800	900	1000	1200	1500
11-LEJS40	●	●	●	●	●	●	●	●	●	●	—
11-LEJS63	—	●	●	●	●	●	●	●	●	●	●

*4 Please consult with SMC for non-standard strokes as they are produced as special orders.

For auto switches, refer to pages 210 to 213.

Compatible Drivers

Driver type	MECHATROLINK-II type	MECHATROLINK-III type
Series	LECYM	LECYU
Applicable network	MECHATROLINK-II	MECHATROLINK-III
Control encoder	Absolute 20-bit encoder	
Communication device	USB communication, RS-422 communication	
Power supply voltage [V]	200 to 230 VAC (50/60 Hz)	
Reference page	801	

11-LEJS Series

AC Servo Motor

Clean Room Specification

Dimensions: Ball Screw Drive

11-LEJS40

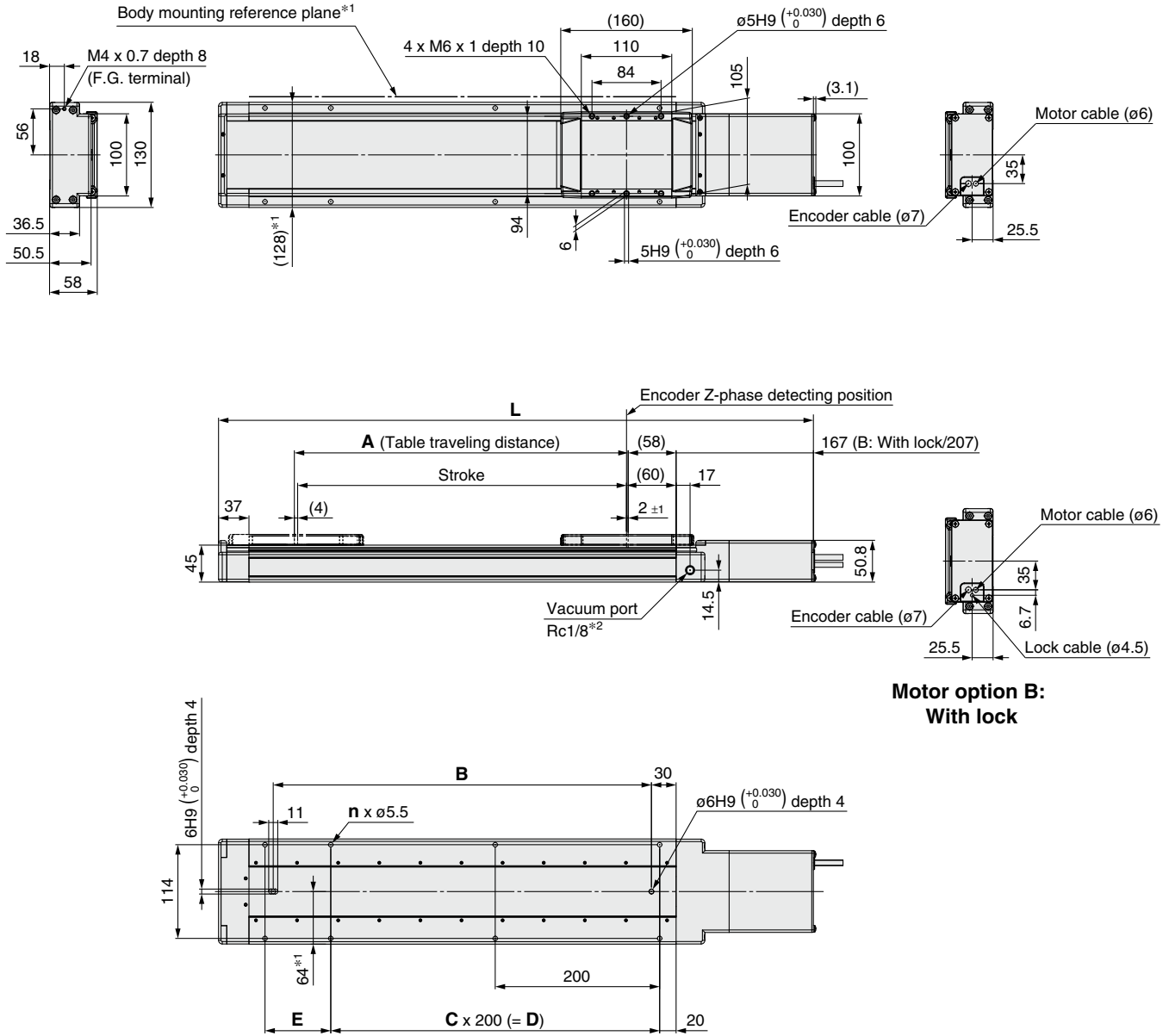

**Motor option B:
With lock**

- *1 When mounting the actuator using the body mounting reference plane, use a pin. Set the height of the pin to be 5 mm or more because of round chamfering. (Recommended height 6 mm)
- *2 This drawing shows the left type.
- * Please consult with SMC for adjusting the Z-phase detecting position at the stroke end of the end side.
- * The amount of particle generation changes according to the operating conditions and suction flow rate.

Model	L		A	B	n	C	D	E
	Without lock	With lock						
11-LEJS40□□□-200□□-□□□□	523.5	563.5	206	260	6	1	200	80
11-LEJS40□□□-300□□-□□□□	623.5	663.5	306	360	6	1	200	180
11-LEJS40□□□-400□□-□□□□	723.5	763.5	406	460	8	2	400	80
11-LEJS40□□□-500□□-□□□□	823.5	863.5	506	560	8	2	400	180
11-LEJS40□□□-600□□-□□□□	923.5	963.5	606	660	10	3	600	80
11-LEJS40□□□-700□□-□□□□	1023.5	1063.5	706	760	10	3	600	180
11-LEJS40□□□-800□□-□□□□	1123.5	1163.5	806	860	12	4	800	80
11-LEJS40□□□-900□□-□□□□	1223.5	1263.5	906	960	12	4	800	180
11-LEJS40□□□-1000□□-□□□□	1323.5	1363.5	1006	1060	14	5	1000	80
11-LEJS40□□□-1200□□-□□□□	1523.5	1563.5	1206	1260	16	6	1200	80

