

● Copper (Cu) and zinc (Zn) free*¹

*1 Excludes motors, cables, controllers/drivers

● Compatible with dew points as low as -70°C

Uses grease compatible with low dew points

Slider Type

Ball Screw Drive/25A-LEFS

Step Motor (Servo/24 VDC)

Servo Motor (24 VDC)

p. 665

Bolts

Material: Stainless steel

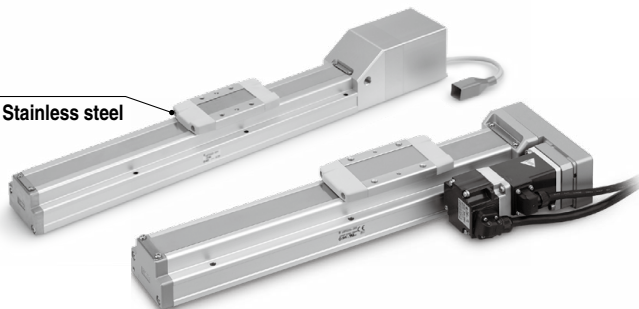

AC Servo Motor

p. 668, 669

	Size 16	25	32	40
Motor type				
Step motor (Servo/24 VDC)	●	●	●	●
Servo motor (24 VDC)	●	●	●	●
AC servo motor		●	●	●

High Rigidity Slider Type

Ball Screw Drive/25A-LEJS

AC Servo Motor

p. 671, 672

Bolts

Material: Stainless steel

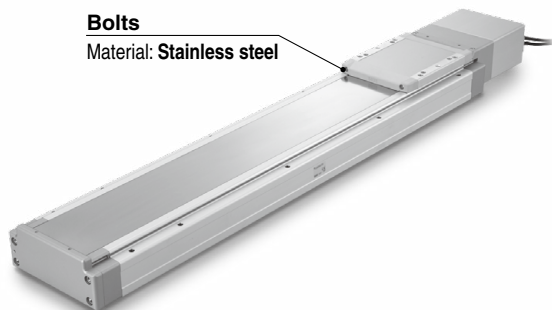

	Size 40	63
Motor type		
AC servo motor	●	●

Rod Type/25A-LEY

Step Motor (Servo/24 VDC)

Servo Motor (24 VDC)

p. 673

Bushing

Material: Steel bearing alloy

Bolts

Material: Stainless steel

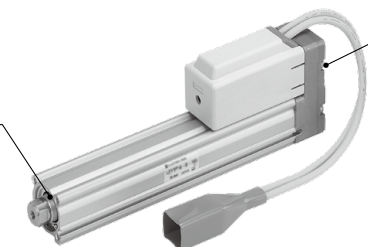

AC Servo Motor

p. 677, 679

Bolts

Material: Stainless steel

Bushing

Material: Steel bearing alloy



	Size 16	25	32	40
Motor type				
Step motor (Servo/24 VDC)	●	●	●	●
Servo motor (24 VDC)	●	●	●	●

	Size 25	32
Motor type		
AC servo motor	●	●

* Copper and zinc materials are used for the motors, cables, controllers/drivers.

Electric Actuator/Slider Type Ball Screw Drive

Secondary Battery Compatible



25A-LEFS Series LEFS16, 25, 32, 40

Refer to page 31 for model selection.

How to Order

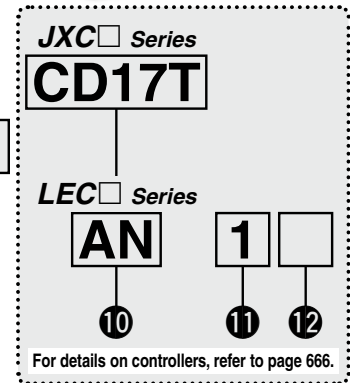
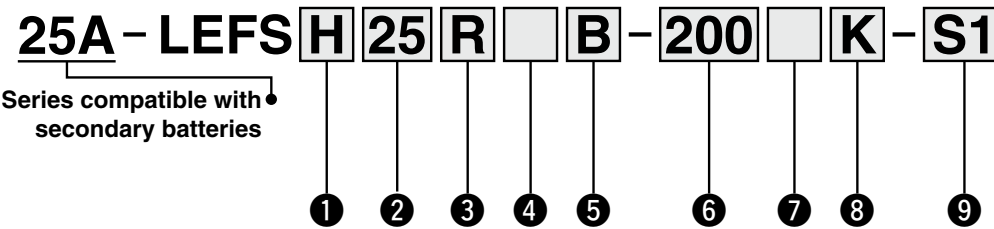

1 Accuracy

Nil	Basic type
H	High-precision type

2 Size

16
25
32
40

3 Motor mounting position

Nil	In-line
R	Right side parallel
L	Left side parallel

4 Motor type

Symbol	Type	Applicable size				Compatible controllers/drivers
		LEFS16	LEFS25	LEFS32	LEFS40	
Nil	Step motor (Servo/24 VDC)	●	●	●	●	JXCE1 LEC P1 JXC91 LEC PA JXCP1 JXCD1 JXCL1 JXCM1 JXC51 JXC61
A	Servo motor (24 VDC)	●	●	—	—	LECA6

5 Lead [mm]

Symbol	LEFS16	LEFS25	LEFS32	LEFS40
A	10	12	16	20
B	5	6	8	10

6 Stroke*1 [mm]

Stroke	Size	Note
		Applicable stroke
50 to 500	16	50, 100, 150, 200, 250, 300, 350, 400, 450, 500
50 to 600	25	50, 100, 150, 200, 250, 300, 350, 400, 450, 500, 550, 600
50 to 800	32	50, 100, 150, 200, 250, 300, 350, 400, 450, 500, 550, 600, 650, 700, 750, 800
150 to 1000	40	150, 200, 250, 300, 350, 400, 450, 500, 550, 600, 650, 700, 750, 800, 850, 900, 950, 1000

7 Motor option

Nil	Without option
B	With lock

8 Positioning pin hole

Nil	Housing B bottom*2	
K	Body bottom 2 locations	

9 Actuator cable type/length*4

Standard cable [m]		Robotic cable [m]	
Nil	None	R1	1.5
S1	1.5*6	R3	3
S3	3*6	RA	10*3
S5	5*6	RB	15*3
		R5	5
		RC	20*3
		R8	8*3

Support Guide/LEFG Series

The support guide was designed to support workpieces with significant overhang.

p. 109

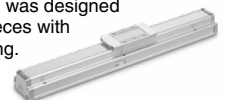

For auto switches, refer to pages 161 to 164.

Electric Actuator/Slider Type Ball Screw Drive **25A-LEFS Series**

Step Motor (Servo/24 VDC)

Servo Motor (24 VDC)

Secondary Battery Compatible

JXC Series (For details, refer to page 667.)

10 Controller

Nil	Without controller
C□1□□	With controller

C D 1 7 T

Interface

(Communication protocol/Input/Output)	
E	EtherCAT®
9	EtherNet/IP™
P	PROFINET
D	DeviceNet™
L	IO-Link
M	CC-Link Ver 1.10
5	Parallel input (NPN)
6	Parallel input (PNP)

Mounting

7	Screw mounting
8*10	DIN rail

For single axis



Communication plug connector I/O cable*11

Symbol	Type	Applicable interface
Nil	Without accessory	—
S	Straight type communication plug connector	DeviceNet™
T	T-branch type communication plug connector	CC-Link Ver 1.10
1	I/O cable (1.5 m)	Parallel input (NPN) Parallel input (PNP)
3	I/O cable (3 m)	
5	I/O cable (5 m)	

LEC Series (For details, refer to page 667.)

AN 1 □

⑩ ⑪ ⑫

10 Controller/Driver type*5

Nil	Without controller/driver	
6N	LECA6	NPN
6P	(Step data input type)	PNP
1N	LECP1*6	NPN
1P	(Programless type)	PNP
AN	LECPA*6 *7	NPN
AP	(Pulse input type)	PNP

11 I/O cable length*8

Nil	Without cable (Without communication plug connector)
1	1.5 m
3	3 m*9
5	5 m*9

12 Controller/Driver mounting

Nil	Screw mounting
D	DIN rail*10



- *1 Please consult with SMC for non-standard strokes as they are produced as special orders.
- *2 Refer to the body mounting example on page 166 for the mounting method.
- *3 Produced upon receipt of order (Robotic cable only)
- *4 The standard cable should only be used on fixed parts. For use on moving parts, select the robotic cable. Refer to pages 758 and 759 if only the actuator cable is required.
- *5 For details on controllers/drivers and compatible motors, refer to the compatible controllers/drivers on the next page.
- *6 Only available for the motor type "Step motor"
- *7 When pulse signals are open collector, order the current limiting resistor (LEC-PA-R-□) on page 736 separately.

- *8 When "Without controller/driver" is selected for controller/driver types, I/O cable cannot be selected. Refer to page 713 (For LECA6), page 724 (For LECP1), or page 736 (For LECPA) if I/O cable is required.
- *9 When "Pulse input type" is selected for controller/driver types, pulse input usable only with differential. Only 1.5 m cables usable with open collector
- *10 The DIN rail is not included. It must be ordered separately.
- *11 Select "Nil" for anything other than DeviceNet™, CC-Link, or parallel input. Select "Nil," "S," or "T" for DeviceNet™ or CC-Link. Select "Nil," "1," "3," or "5" for parallel input.

⚠ Caution

[CE-compliant products]

- ① EMC compliance was tested by combining the electric actuator LEF series and the controller LEC/JXC series. The EMC depends on the configuration of the customer's control panel and the relationship with other electrical equipment and wiring. Therefore, compliance with the EMC directive cannot be certified for SMC components incorporated into the customer's equipment under actual operating conditions. As a result, it is necessary for the customer to verify compliance with the EMC directive for the machinery and equipment as a whole.
- ② For the servo motor (24 VDC) specification, EMC compliance was tested by installing a noise filter set (LEC-NFA). Refer to page 713 for the noise filter set. Refer to the LECA series Operation Manual for installation.

[UL-compliant products (For the LEC series)]

When compliance with UL is required, the electric actuator and controller/driver should be used with a UL1310 Class 2 power supply.

The actuator and controller/driver are sold as a package.

Confirm that the combination of the controller/driver and actuator is correct.

<Check the following before use.>

- ① Check the actuator label for the model number (after "25A-"). This number should match that of the controller/driver.
- ② Check that the Parallel I/O configuration matches (NPN or PNP).

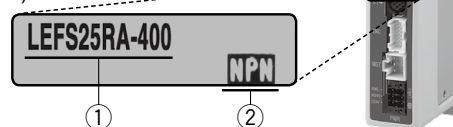

* Refer to the Operation Manual for using the products. Please download it via our website: <https://www.smcworld.com>

LEFS
LEFB

LEJS
LEJB

LEL

LEM

LEY
LEYG

LES
LESH

LEPY
LEPS

LER

LEH

LEY-X5

11-LEFS

11-LEJS

25A-

LEC□

JXC□

LECS□
LECS□-T

LECY□

Motorless

LAT3







25A-LEFS Series





Step Motor (Servo/24 VDC)

Servo Motor (24 VDC)

Secondary Battery Compatible

Compatible Controllers/Drivers

Type	EtherCAT® direct input type 	EtherNet/IP™ direct input type 	PROFINET direct input type 	DeviceNet™ direct input type 	IO-Link direct input type 	CC-Link direct input type 
Series	JXCE1	JXC91	JXCP1	JXCD1	JXCL1	JXCM1
Features	EtherCAT® direct input	EtherNet/IP™ direct input	PROFINET direct input	DeviceNet™ direct input	IO-Link direct input	CC-Link direct input
Compatible motor	Step motor (Servo/24 VDC)					
Max. number of step data	64 points					
Power supply voltage	24 VDC					
Reference page	741					

Type	Step data input type 	Step data input type 	Programless type 	Pulse input type 
Series	JXC51 JXC61	LECA6	LECP1	LECPA
Features	Parallel I/O	Value (Step data) input Standard controller	Capable of setting up operation (step data) without using a PC or teaching box	Operation by pulse signals
Compatible motor	Step motor (Servo/24 VDC)	Servo motor (24 VDC)	Step motor (Servo/24 VDC)	
Max. number of step data	64 points		14 points	—
Power supply voltage	24 VDC			
Reference page	706-1	707	719	731

Electric Actuator/Slider Type Ball Screw Drive

Secondary Battery Compatible



25A-LEFS Series LEFS25, 32, 40

Refer to page 39 for model selection.



LECY Series ▶ p. 669

How to Order

25A-LEFS H 32 R S3 B - 200 K - S 2 A2

Series compatible with secondary batteries

1 Accuracy

Nil	Basic type
H	High-precision type

2 Size

25
32
40

3 Motor mounting position

Nil	In-line
R	Right side parallel
L	Left side parallel

5 Lead [mm]

Symbol	25A-LEFS25	25A-LEFS32	25A-LEFS40
A	12	16	20
B	6	8	10

6 Stroke [mm]

50 to 1000	50 to 1000
------------	------------

7 Motor option

Nil	Without option
B	With lock

* For details, refer to the applicable stroke table below.

4 Motor type

Symbol	Type	Output [W]	Actuator size	Compatible drivers	UL-compliant		
S2*1	AC servo motor (Incremental encoder)	100	25	LECSA□-S1	●		
S3		200	32	LECSA□-S3	●		
S4		400	40	LECSA2-S4	●		
S6*1	AC servo motor (Absolute encoder)	100	25	LECSB□-S5	—		
S7				200	32	LECSB□-S7	—
S8		400	40	LECSB2-S8	—		
				LECSB2-S8	—		
T6*2	AC servo motor (Absolute encoder)	100	25	LECSB2-T5	—		
T7				200	32	LECSB2-T7	—
						400	40
T8	200	32	LECSB2-T8	—			
T8	400	40	LECSN2-T8-□	—			
			LECSN2-T8-□	●			

*1 For motor type S2 and S6, the compatible driver part number suffixes are S1 and S5 respectively.

*2 For motor type T6, the compatible driver part number is LECS□2-T5.

8 Positioning pin hole

Nil	Housing B bottom*1	
K	Body bottom 2 locations	

*1 Refer to the body mounting example on page 166 for the mounting method.

9 Cable type*1 *2

Nil	Without cable
S	Standard cable
R	Robotic cable (Flexible cable)

*1 The motor and encoder cables are included. (The lock cable is also included when the motor with lock option is selected.)

*2 Standard cable entry direction is
· Parallel: (A) Axis side
· In-line: (B) Counter axis side

10 Cable length*1 [m]

Nil	Without cable
2	2
5	5
A	10

*1 The length of the encoder, motor, and lock cables are the same.

12 I/O cable length [m]*3

Nil	Without cable
H	Without cable (Connector only)
1	1.5

*3 When "Without driver" is selected for driver type, only "Nil: Without cable" can be selected. Refer to page 797 if I/O cable is required. (Options are shown on page 797.)

11 Driver type

Compatible drivers	Power supply voltage [V]	Size			UL-compliant
		25	32	40	
Nil	Without driver	—	—	—	—
A1	100 to 120	●	●	—	—
A2	200 to 230	●	●	●	●
B1	100 to 120	●	●	—	—
B2	200 to 230	●	●	●	●
	200 to 240	●	●	●	●
C1	100 to 120	●	●	—	—
C2	200 to 230	●	●	—	—
	200 to 240	●	●	—	—
S1	100 to 120	●	●	—	—
S2	200 to 230	●	●	—	—
	200 to 240	●	●	—	—
N2	200 to 240	●	●	●	●
92	200 to 240	●	●	—	—
E2	200 to 240	●	●	—	—
P2	200 to 240	●	●	—	—

* When a driver type is selected, a cable is included. Select the cable type and cable length. Example) S2S2: Standard cable (2 m) + Driver (LECS2) S2: Standard cable (2 m) Nil: Without cable and driver

* The 25A- series specifications and dimensions are the same as those of the standard model.

Applicable Stroke Table

Model	Stroke [mm]																Manufacturable stroke range [mm]				
	50	100	150	200	250	300	350	400	450	500	550	600	650	700	750	800		850	900	950	1000
25A-LEFS25	●	●	●	●	●	●	●	●	●	●	●	●	●	—	—	—	—	—	—	—	50 to 600
25A-LEFS32	●	●	●	●	●	●	●	●	●	●	●	●	●	●	●	●	●	—	—	—	50 to 800
25A-LEFS40	—	—	●	●	●	●	●	●	●	●	●	●	●	●	●	●	●	●	●	●	150 to 1000

* Please consult with SMC for non-standard strokes as they are produced as special orders.

Compatible Drivers*1

Driver type	Pulse input type/ Positioning type	Pulse input type	CC-Link direct input type	SSCNET III type	Pulse input type	CC-Link direct input type	SSCNET III/H type	Network card type
Series	LECSA	LECSB	LECSA	LECSS	LECSB-T	LECSA-T	LECSS-T	LECSN-T
Number of point tables*2	Up to 7	—	Up to 255 (2 stations occupied)	—	Up to 255	Up to 255 (2 stations occupied)	—	Up to 255
Pulse input	○	○	—	—	○	—	—	—
Applicable network	—	—	CC-Link	SSCNET III	—	CC-Link	SSCNET III/H	PROFINET EtherCAT® EtherNet/IP™
Control encoder	Incremental 17-bit encoder	Absolute 18-bit encoder	Absolute 18-bit encoder	Absolute 18-bit encoder	Absolute 22-bit encoder	Absolute 18-bit encoder	Absolute 22-bit encoder	Absolute 22-bit encoder
Communication function	USB communication	USB communication, RS422 communication	USB communication	USB communication	USB communication, RS422 communication	USB communication	USB communication	USB communication
Power supply voltage [V]	100 to 120 VAC (50/60 Hz), 200 to 230 VAC (50/60 Hz)	100 to 120 VAC (50/60 Hz), 200 to 230 VAC (50/60 Hz)	100 to 120 VAC (50/60 Hz), 200 to 230 VAC (50/60 Hz)	100 to 120 VAC (50/60 Hz), 200 to 230 VAC (50/60 Hz)	100 to 120 VAC (50/60 Hz), 200 to 230 VAC (50/60 Hz)	100 to 120 VAC (50/60 Hz), 200 to 230 VAC (50/60 Hz)	100 to 120 VAC (50/60 Hz), 200 to 230 VAC (50/60 Hz)	100 to 120 VAC (50/60 Hz), 200 to 230 VAC (50/60 Hz)
Reference page	777							

*1 Copper and zinc materials are used for the motors, cables, controllers/drivers. *2 The LECSN-T only supports PROFINET and EtherCAT®.

Electric Actuator/Slider Type Ball Screw Drive

Secondary Battery Compatible

25A-LEFS Series LEFS25, 32, 40



Refer to page 47 for model selection.

LECY □ Series ▶ p. 668

How to Order

25A-LEFS H 32 R V7 B - 200 □ K - S 2 M2 □

Series compatible with secondary batteries

1 Accuracy

Nil	Basic type
H	High-precision type

2 Size

25
32
40

3 Motor mounting position

Nil	In-line
R	Right side parallel
L	Left side parallel

5 Lead [mm]

Symbol	LEFS25	LEFS32	LEFS40
A	12	16	20
B	6	8	10

6 Stroke [mm]

50	50
to	to
1000	1000

7 Motor option

Nil	Without option
B	With lock

* For details, refer to the applicable stroke table below.

4 Motor type

Symbol	Type	Output [W]	Size	Compatible drivers
V6*1	AC servo motor	100	25	LECYM2-V5/LECYU2-V5
V7	(Absolute encoder)	200	32	LECYM2-V7/LECYU2-V7
V8	(Encoder)	400	40	LECYM2-V8/LECYU2-V8

*1 For motor type V6, the compatible driver part number suffix is V5.

12 I/O cable length [m]*3

Nil	Without cable
H	Without cable (Connector only)
1	1.5

*3 When "Without driver" is selected for driver type, only "Nil: Without cable" can be selected. Refer to page 808 if I/O cable is required. (Options are shown on page 808.)

8 Positioning pin hole

Nil	Housing B bottom*1	
K	Body bottom 2 locations	

*1 Refer to the body mounting example on page 166 for the mounting method.

10 Cable length*1 [m]

Nil	Without cable
3	3
5	5
A	10
C	20

*1 The length of the encoder, motor, and lock cables are the same.

9 Cable type*1 *2

Nil	Without cable
S	Standard cable
R	Robotic cable (Flexible cable)

*1 The motor and encoder cables are included. (The lock cable is also included when the motor with lock option is selected.)

*2 Standard cable entry direction is
· Parallel: (A) Axis side
· In-line: (B) Counter axis side

11 Driver type

	Compatible drivers	Power supply voltage [V]
Nil	Without driver	—
M2	LECYM2-V□	200 to 230
U2	LECYU2-V□	200 to 230

Applicable Stroke Table

Model	Stroke [mm]															Manufacturable stroke range [mm]					
	50	100	150	200	250	300	350	400	450	500	550	600	650	700	750		800	850	900	950	1000
25A-LEFS25	●	●	●	●	●	●	●	●	●	●	●	●	●	—	—	—	—	—	—	—	50 to 600
25A-LEFS32	●	●	●	●	●	●	●	●	●	●	●	●	●	●	●	●	●	—	—	—	50 to 800
25A-LEFS40	—	—	●	●	●	●	●	●	●	●	●	●	●	●	●	●	●	●	●	●	150 to 1000

* Please consult with SMC for non-standard strokes as they are produced as special orders.

* The 25A- series specifications and dimensions are the same as those of the standard model.

Compatible Drivers

Driver type	MECHATROLINK- II type	MECHATROLINK- III type
Series	LECYM	LECYU
Applicable network	MECHATROLINK-II	MECHATROLINK-III
Control encoder	Absolute 20-bit encoder	
Communication device	USB communication, RS-422 communication	
Power supply voltage [V]	200 to 230 VAC (50/60 Hz)	
Reference page	801	

* Copper and zinc materials are used for the motors, cables, controllers/drivers.

- LAT3
- Motorless
- LECY
- LECS JXC LEC
- LECS T
- 11-LEJS
- 11-LEFS
- LEY-X5
- LEH
- LER
- LEPY
LEPS
- LES
LESH
- LEY
LEYG
- LEM
- LEL
- LEJS
LEJB
- LEFS
LEFB

Electric Actuator/High Rigidity Slider Type Ball Screw Drive

Secondary Battery Compatible

25A-LEJS Series LEJS40, 63



Refer to page 175 for model selection.

LECY □ Series ▶ p. 672

How to Order



* See the table below.

25A-LEJS **H** **40** **S2** **A** - **500** □ - □ □ □ □

Series compatible with secondary batteries

① ② ③ ④ ⑤ ⑥ ⑦ ⑧ ⑨ ⑩

① Accuracy

Nil	Basic type
H	High-precision type

② Size

40
63

⑤ Stroke [mm]^{*3}

200
to
1500

*3 Refer to the applicable stroke table for details.

⑥ Motor option

Nil	Without option
B	With lock

③ Motor type

Symbol	Type	Output [W]	Actuator size	Compatible ^{*3} drivers	UL-compliant
S2 ^{*1}	AC servo motor (Incremental encoder)	100	40	LECSA□-S1	●
S3	AC servo motor (Incremental encoder)	200	63	LECSA□-S3	●
S6 ^{*1}	AC servo motor (Absolute encoder)	100	40	LECSB□-S5 LECS□-S5 LECSS□-S5	—
S7	AC servo motor (Absolute encoder)	200	63	LECSB□-S7 LECS□-S7 LECSS□-S7	—
T6 ^{*2}	AC servo motor (Absolute encoder)	100	40	LECSB2-T5 LECS□2-T5 LECSN2-T5-□	—
				LECSS2-T5	●
				LECSB2-T7 LECS□2-T7 LECSN2-T7-□	—
T7		200	63	LECSS2-T7	●

*1 For motor type S2 and S6, the compatible driver part number suffixes are S1 and S5 respectively.

*2 For motor type T6, the compatible driver part number is LECS□2-T5.

④ Lead [mm]

Symbol	25A-LEJS40	25A-LEJS63
H	24	30
A	16	20
B	8	10

⑨ Driver type^{*5}

	Compatible drivers	Power supply voltage [V]	UL-compliant
Nil	Without driver	—	—
A1	LECSA1-S□	100 to 120	●
A2	LECSA2-S□	200 to 230	●
B1	LECSB1-S□	100 to 120	—
B2	LECSB2-S□	200 to 230	—
	LECSB2-T□	200 to 240	●
C1	LECS□1-S□	100 to 120	—
	LECS□2-S□	200 to 230	—
C2	LECS□2-T□	200 to 230	●
	LECS□2-T□	200 to 230	●
S1	LECSS1-S□	100 to 120	—
S2	LECSS2-S□	200 to 230	—
	LECSS2-T□	200 to 240	●
N2	LECSN2-T□	200 to 240	●
92	LECSN2-T□-9	200 to 240	—
E2	LECSN2-T□-E	200 to 240	—
P2	LECSN2-T□-P	200 to 240	—

*5 When a driver type is selected, a cable is included. Select the cable type and cable length.

Example)

S2S2: Standard cable (2 m) + Driver (LECSS2)

S2: Standard cable (2 m)

Nil: Without cable and driver

⑩ I/O cable length [m]^{*9}

Nil	Without cable
H	Without cable (Connector only)
1	1.5

*9 When "Without driver" is selected for driver type, only "Nil: Without cable" can be selected.

Refer to page 797 if I/O cable is required.

For auto switches, refer to page 681.

⑦ Cable type^{*5, *6, *7}

Nil	Without cable
S	Standard cable
R	Robotic cable (Flexible cable)

*6 The motor and encoder cables are included. (The lock cable is included when the motor with lock option is selected.)

*7 Standard cable entry is "(A) Axis side."

⑧ Cable length [m]^{*5, *8}

Nil	Without cable
2	2
5	5
A	10

*8 The length of the motor, encoder, and lock cables are the same.

Applicable Stroke Table^{*4}

Model	Stroke [mm]										
	200	300	400	500	600	700	800	900	1000	1200	1500
25A-LEJS40	●	●	●	●	●	●	●	●	●	●	—
25A-LEJS63	—	●	●	●	●	●	●	●	●	●	●

*4 Please consult with SMC for non-standard strokes as they are produced as special orders.

Compatible Drivers^{*10}

* The 25A-series specifications and dimensions are the same as those of the standard model.

Driver type	Pulse input type/ Positioning type	Pulse input type	CC-Link direct input type	SSCNET III type	Pulse input type	CC-Link direct input type	SSCNET III/H type	Network card type
Series	LECSA	LECSB	LECS□	LECSS	LECSB-T	LECS□-T	LECSS-T	LECSN-T
Number of point tables ^{*11}	Up to 7	—	Up to 255	—	Up to 255	Up to 255 (2 stations occupied)	—	Up to 255
Pulse input	○	○	—	—	○	—	—	—
Applicable network	—	—	CC-Link	SSCNET III	—	CC-Link	SSCNET III/H	PROFINET EtherCAT® EtherNet/IP™
Control encoder	Incremental 17-bit encoder	Absolute 18-bit encoder	Absolute 18-bit encoder	Absolute 18-bit encoder	Absolute 22-bit encoder	Absolute 18-bit encoder	Absolute 22-bit encoder	Absolute 22-bit encoder
Communication function	USB communication	USB communication, RS422 communication	USB communication	USB communication	USB communication, RS422 communication	USB communication	USB communication	USB communication
Power supply voltage [V]	100 to 120 VAC (50/60 Hz), 200 to 230 VAC (50/60 Hz)		200 to 240 VAC (50/60 Hz)		200 to 240 VAC (50/60 Hz)		200 to 240 VAC (50/60 Hz)	
Reference page	777							

*10 Copper and zinc materials are used for the motors, cables, controllers/drivers. *11 The LECSN-T only supports PROFINET and EtherCAT®.

Electric Actuator/High Rigidity Slider Type Ball Screw Drive

Secondary Battery Compatible

25A-LEJS Series LEJS40, 63



Refer to page 186 for model selection.

LECS□ Series ▶ p. 671

How to Order

25A-LEJS **H** **40** **V6** **A** - **500** □ - □ □ □ □

Series compatible with secondary batteries

1 Accuracy

Nil	Basic type
H	High-precision type

2 Size

40
63

3 Motor type *1

Symbol	Type	Output [W]	Actuator size	Compatible drivers
V6	AC servo motor (Absolute encoder)	100	40	LECYM2-V5 LECYU2-V5
V7	AC servo motor (Absolute encoder)	200	63	LECYM2-V7 LECYU2-V7

*1 For motor type V6, the compatible driver part number suffix is V5.

4 Lead [mm]

Symbol	25A-LEJS40	25A-LEJS63
H	24	30
A	16	20
B	8	10

5 Stroke [mm]*3

200
to
1500

*3 Refer to the applicable stroke table for details.

6 Motor option

Nil	Without option
B	With lock

7 Cable type*5, *6, *7

Nil	Without cable
S	Standard cable
R	Robotic cable (Flexible cable)

*6 The motor and encoder cables are included. (The lock cable is included when the motor with lock option is selected.)

*7 Standard cable entry is "(A) Axis side."

8 Cable length [m] *5, *8

Nil	Without cable
3	3
5	5
A	10
C	20

*8 The length of the motor, encoder, and lock cables are the same.

9 Driver type *5

	Compatible drivers	Power supply voltage [V]
Nil	Without driver	—
M2	LECYM2-V□	200 to 230
U2	LECYU2-V□	200 to 230

*5 When a driver type is selected, a cable is included. Select the cable type and cable length.

Example)

S2S2: Standard cable (2 m) + Driver (LECSS2)

S2: Standard cable (2 m)

Nil: Without cable and driver

10 I/O cable length [m]*9

Nil	Without cable
H	Without cable (Connector only)
1	1.5

*9 When "Without driver" is selected for driver type, only "Nil: Without cable" can be selected. Refer to page 808 if I/O cable is required.

Applicable Stroke Table*4

Model	Stroke [mm]	●: Standard											
		200	300	400	500	600	700	800	900	1000	1200	1500	
25A-LEJS40		●	●	●	●	●	●	●	●	●	●	●	—
25A-LEJS63		—	●	●	●	●	●	●	●	●	●	●	●

*4 Please consult with SMC for non-standard strokes as they are produced as special orders.

Solid state auto switches should be ordered separately. For details on auto switches, refer to page 681.

Applicable auto switches

D-M9N(V)-900, D-M9P(V)-900, D-M9B(V)-900
D-M9NW(V)-900, D-M9PW(V)-900, D-M9BW(V)-900

* The 25A- series specifications and dimensions are the same as those of the standard model.

Compatible Drivers

Driver type	MECHATROLINK-II type	MECHATROLINK-III type
Series	LECYM	LECYU
Applicable network	MECHATROLINK-II	MECHATROLINK-III
Control encoder	Absolute 20-bit encoder	
Communication device	USB communication, RS-422 communication	
Power supply voltage [V]	200 to 230 VAC (50/60 Hz)	
Reference page	801	

* Copper and zinc materials are used for the motors, cables, controllers/drivers.

- LEFS
- LEFB
- LEJS
- LEJB
- LEL
- LEM
- LESH
- LESG
- LESH
- LESL
- LEPY
- LEPS
- LER
- LEH
- LEY-X5
- 11-LEFS
- 11-LEJS
- 25A-
- LEC□
- JXC□
- LECS□
- LECS□-T
- LECY□
- Motorless
- LAT3

Electric Actuator Rod Type

Secondary Battery Compatible

25A-LEY Series LEY16, 25, 32, 40



Refer to page 299 for model selection.

Dust-tight/Water-jet-proof ▶ p. 611

How to Order

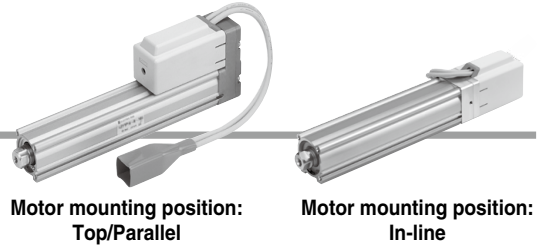

Motor mounting position:
Top/Parallel

Motor mounting position:
In-line

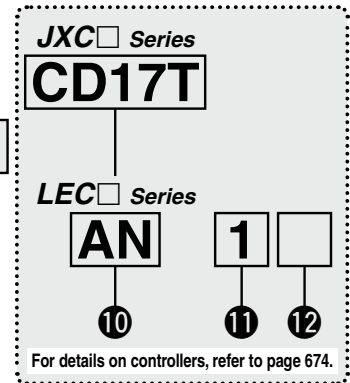
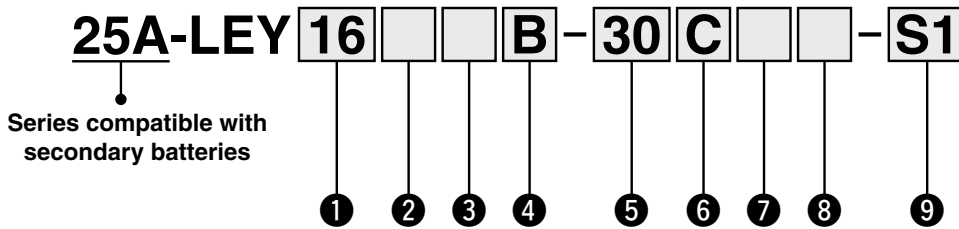

1 Size

16
25
32
40

2 Motor mounting position

Nil	Top mounting
R	Right side parallel
L	Left side parallel
D	In-line

3 Motor type

Symbol	Type	Applicable size			Compatible controllers/drivers		
		LEY16	LEY25	LEY32/40			
Nil	Step motor (Servo/24 VDC)	●	●	●	JXCE1 JXC91 JXCP1 JXCD1 JXCL1	JXCM1 JXC51 JXC61	LECP1 LECPA
A	Servo motor (24 VDC)	●	●	—	LECA6		

4 Lead [mm]

Symbol	LEY16	LEY25	LEY32/40
A	10	12	16
B	5	6	8
C	2.5	3	4

5 Stroke [mm]

30	30
to	to
500	500

* For details, refer to the applicable stroke table below.

6 Motor option*2

C	With motor cover
W	With lock/motor cover

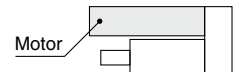

7 Rod end thread

Nil	Rod end female thread
M	Rod end male thread (1 rod end nut is included.)

8 Mounting*5

Symbol	Type	Motor mounting position	
		Top/Parallel	In-line
Nil	Ends tapped/Body bottom tapped*6	●	●
L	Foot	●	—
F	Rod flange*6	●*8	●
G	Head flange*6	●*9	—
D	Double clevis*7	●	—

9 Actuator cable type/length*11

Standard cable [m]		Robotic cable [m]			
Symbol	Length	Symbol	Length	Symbol	Length
Nil	None	R1	1.5	RA	10*10
S1	1.5*12	R3	3	RB	15*10
S3	3*12	R5	5	RC	20*10
S5	5*12	R8	8*10		

Mounting Bracket Part Nos. for the 25A- Series*4

Applicable size	Foot*3	Flange	Double clevis
16	25-LEY-L016	25-LEY-F016	25-LEY-D016
25	25-LEY-L025	25-LEY-F025	25-LEY-D025
32, 40	25-LEY-L032	25-LEY-F032	25-LEY-D032
Surface treatment	RAYDENT®	RAYDENT®	Coating (Size 16: Electroless nickel plating)

Solid state auto switches should be ordered separately. For details on auto switches, refer to page 681.

Applicable auto switches

D-M9N(V)-900, D-M9P(V)-900, D-M9B(V)-900
D-M9NW(V)-900, D-M9PW(V)-900, D-M9BW(V)-900

Applicable Stroke Table*1

Model	Stroke [mm]	Stroke [mm]										Manufacturable stroke range	
		30	50	100	150	200	250	300	350	400	450		500
25A-LEY16		●	●	●	●	●	●	●	—	—	—	—	10 to 300
25A-LEY25		●	●	●	●	●	●	●	●	●	—	—	15 to 400
25A-LEY32/40		●	●	●	●	●	●	●	●	●	●	●	20 to 500

●: Standard

Electric Actuator Rod Type **25A-LEY Series**

Step Motor (Servo/24 VDC)

Servo Motor (24 VDC)

Secondary Battery Compatible

JXC Series (For details, refer to page 675.)

10 Controller

Nil	Without controller
C□1□□	With controller

C D 1 7 T

Interface

(Communication protocol/Input/Output)

E	EtherCAT®	L	IO-Link
9	EtherNet/IP™	M	CC-Link Ver 1.10
P	PROFINET	5	Parallel input (NPN)
D	DeviceNet™	6	Parallel input (PNP)

Mounting

7	Screw mounting
8 *17	DIN rail

For single axis



Communication plug connector I/O cable*18

Symbol	Type	Applicable interface
Nil	Without accessory	—
S	Straight type communication plug connector	DeviceNet™ CC-Link Ver 1.10
T	T-branch type communication plug connector	DeviceNet™ CC-Link Ver 1.10
1	I/O cable (1.5 m)	Parallel input (NPN) Parallel input (PNP)
3	I/O cable (3 m)	
5	I/O cable (5 m)	

LEC Series (For details, refer to page 675.)

AN 1

10 11 12

10 Controller/Driver type*12

Nil	Without controller/driver	
6N	LECA6	NPN
6P	(Step data input type)	PNP
1N	LECP1 *13	NPN
1P	(Programless type)	PNP
AN	LECPA *13 *14	NPN
AP	(Pulse input type)	PNP

11 I/O cable length*15

Nil	Without cable (Without communication plug connector)
1	1.5 m
3	3 m*16
5	5 m*16

12 Controller/Driver mounting

Nil	Screw mounting
D	DIN rail*17



- *1 Please consult with SMC for non-standard strokes as they are produced as special orders.
- *2 When "With lock" or "With lock/motor cover" is selected for the top mounting and right/left side parallel types, the motor body will stick out from the end of the body for size 16/40 with strokes of 30 mm or less. Check for interference with workpieces before selecting a model.
- *3 When ordering foot brackets, order 2 pieces per actuator.
- *4 Parts belonging to each bracket are as follows.
Foot, Flange: Body mounting bolt, Double clevis: Clevis pin, Type C retaining ring for axis, Body mounting bolt
- *5 The mounting bracket is shipped together with the product but does not come assembled.
- *6 For the horizontal cantilever mounting of the rod flange, head flange, or ends tapped types, use the actuator within the following stroke range.
-LEY25: 200 mm or less -LEY32/40: 100 mm or less
- *7 For the mounting of the double clevis type, use the actuator within the following stroke range.
-LEY16: 100 mm or less -LEY25: 200 mm or less -LEY32/40: 200 mm or less
- *8 The rod flange type is not available for the LEY16/40 with a 30 mm stroke and motor option "With lock," "With lock/motor cover."
- *9 The head flange type is not available for the LEY32/40.
- *10 Produced upon receipt of order (Robotic cable only)

- *11 The standard cable should only be used on fixed parts. For use on moving parts, select the robotic cable. Refer to pages 758 and 759 if only the actuator cable is required.
- *12 For details on controllers/drivers and compatible motors, refer to the compatible controllers/drivers on the next page.
- *13 Only available for the motor type "Step motor"
- *14 When pulse signals are open collector, order the current limiting resistor (LEC-PA-R-□) on page 736 separately.
- *15 When "Without controller/driver" is selected for controller/driver types, I/O cable cannot be selected. Refer to page 713 (For LECA6), page 724 (For LECP1), or page 736 (For LECPA) if I/O cable is required.
- *16 When "Pulse input type" is selected for controller/driver types, pulse input usable only with differential. Only 1.5 m cables usable with open collector
- *17 The DIN rail is not included. It must be ordered separately.
- *18 Select "Nil" for anything other than DeviceNet™, CC-Link, or parallel input. Select "Nil," "S," or "T" for DeviceNet™ or CC-Link. Select "Nil," "1," "3," or "5" for parallel input.

⚠ Caution

[CE-compliant products]

- ① EMC compliance was tested by combining the electric actuator LEY series and the controller LEC/JXC series.
The EMC depends on the configuration of the customer's control panel and the relationship with other electrical equipment and wiring. Therefore, compliance with the EMC directive cannot be certified for SMC components incorporated into the customer's equipment under actual operating conditions. As a result, it is necessary for the customer to verify compliance with the EMC directive for the machinery and equipment as a whole.
- ② For the servo motor (24 VDC) specification, EMC compliance was tested by installing a noise filter set (LEC-NFA). Refer to page 713 for the noise filter set. Refer to the LECA series Operation Manual for installation.

[UL-compliant products (For the LEC series)]

When compliance with UL is required, the electric actuator and controller/driver should be used with a UL1310 Class 2 power supply.

The actuator and controller/driver are sold as a package.

Confirm that the combination of the controller/driver and actuator is correct.

<Check the following before use.>

- ① Check the actuator label for the model number (after "25A-"). This number should match that of the controller/driver.
- ② Check that the Parallel I/O configuration matches (NPN or PNP).

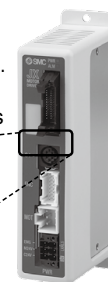
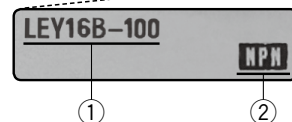

* Refer to the Operation Manual for using the products. Please download it via our website: <https://www.smcworld.com>

LEFS
LEFB

LEJS
LEJB

LEL

LEM

LEY
LEYG

LES
LESH

LEPY
LEPS

LER

LEH

LEY-X5

11-LEFS

11-LEJS

25A-

LEC

JXC

LECS
LECS-T

LECY

Motorless

LAT3







25A-LEY Series





Step Motor (Servo/24 VDC)

Servo Motor (24 VDC)

Secondary Battery Compatible

Compatible Controllers/Drivers

Type	EtherCAT® direct input type 	EtherNet/IP™ direct input type 	PROFINET direct input type 	DeviceNet™ direct input type 	IO-Link direct input type 	CC-Link direct input type 
Series	JXCE1	JXC91	JXCP1	JXCD1	JXCL1	JXCM1
Features	EtherCAT® direct input	EtherNet/IP™ direct input	PROFINET direct input	DeviceNet™ direct input	IO-Link direct input	CC-Link direct input
Compatible motor	Step motor (Servo/24 VDC)					
Max. number of step data	64 points					
Power supply voltage	24 VDC					
Reference page	741					

Type	Step data input type 	Step data input type 	Programless type 	Pulse input type 
Series	JXC51 JXC61	LECA6	LECP1	LECPA
Features	Parallel I/O	Value (Step data) input Standard controller	Capable of setting up operation (step data) without using a PC or teaching box	Operation by pulse signals
Compatible motor	Step motor (Servo/24 VDC)	Servo motor (24 VDC)	Step motor (Servo/24 VDC)	
Max. number of step data	64 points		14 points	—
Power supply voltage	24 VDC			
Reference page	706-1	707	719	731

- LAT3
- Motorless
- LECY
- LECS JXC LEC
- LECS T
- 11-LEJS
- 11-LEFS
- LEY-X5
- LEH
- LER
- LEPY
LEPS
- LES
LESH
- LEY
LEYG
- LEM
- LEL
- LEJS
LEJB
- LEFS
LEFB

Electric Actuator Rod Type

Secondary Battery Compatible



25A-LEY Series LEY25, 32 Size 25, 32

RoHS

LECY □ Series ▶ p. 679

Dust-tight/Water-jet-proof ▶ p. 619

Refer to page 305 for model selection.

How to Order

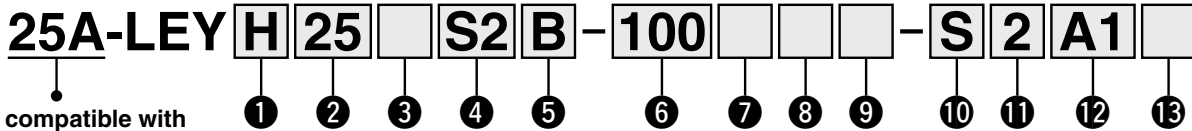

Series compatible with secondary batteries

1 Accuracy

Nil	Basic type
H	High-precision type

2 Size

25
32

3 Motor mounting position

Nil	Top mounting
R	Right side parallel
L	Left side parallel
D	In-line

5 Lead [mm]

Symbol	LEY25	LEY32*1
A	12	16 (20)
B	6	8 (10)
C	3	4 (5)

*1 The values shown in () are the leads for the size 32 top mounting, right/left side parallel types. (Equivalent leads which include the pulley ratio [1.25:1])

4 Motor type*1

Symbol	Type	Output [W]	Actuator size	Compatible drivers*3	UL-compliant
S2*1	AC servo motor (Incremental encoder)	100	25	LECSA□-S1	●
S3		200	32	LECSA□-S3	●
S6*1	AC servo motor (Absolute encoder)	100	25	LECSB□-S5	—
S7				200	
		T6*2	100	25	
T7	200	32			LECSB2-T7
			LECSN2-T5-□	●	
			LECSN2-T7-□		●

*1 For motor type S2 and S6, the compatible driver part number suffixes are S1 and S5 respectively.

*2 For motor type T6, the compatible driver part number is LECS□2-T5.

*3 For details on the driver, refer to page 777.

6 Stroke [mm]

30	30
to	to
500	500

* For details, refer to the applicable stroke table below.

8 Rod end thread

Nil	Rod end female thread
M	Rod end male thread (1 rod end nut is included.)

7 Motor option

Nil	Without option
B	With lock*1

*1 When "With lock" is selected for the top mounting and right/left side parallel types, the motor body will stick out from the end of the body for size 25 with strokes of 30 mm or less. Check for interference with workpieces before selecting a model.

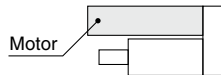

9 Mounting*1

Symbol	Type	Motor mounting position	
		Top/Parallel	In-line
Nil	Ends tapped/ Body bottom tapped*2	●	●
L	Foot	●	—
F	Rod flange*2	●*4	●
G	Head flange*2	●*5	—
D	Double clevis*3	●	—

*1 The mounting bracket is shipped together with the product but does not come assembled.

*2 For the horizontal cantilever mounting of the rod flange, head flange, or ends tapped types, use the actuator within the following stroke range.

- 25A-LEY25: 200 mm or less
- 25A-LEY32: 100 mm or less

*3 For the mounting of the double clevis type, use the actuator within the following stroke range.

- 25A-LEY25: 200 mm or less
- 25A-LEY32: 200 mm or less

*4 The rod flange type is not available for the 25A-LEY25 with a 30 mm stroke and motor option "With lock."

*5 The head flange type is not available for the 25A-LEY32.

Mounting Bracket Part Nos. for the 25A- Series

Applicable size	Foot*1	Flange	Double clevis
25	25-LEY-L025	25-LEY-F025	25-LEY-D025
32	25-LEY-L032	25-LEY-F032	25-LEY-D032
Surface treatment	RAYDENT®	RAYDENT®	Coating (Size 16: Electroless nickel plating)

*1 When ordering foot brackets, order 2 pieces per actuator.

* Parts belonging to each bracket are as follows.

Foot, Flange: Body mounting bolt, Double clevis: Clevis pin, Type C retaining ring for axis, Body mounting bolt

Applicable Stroke Table

Model	Stroke [mm]	●: Standard										Manufacturable stroke range [mm]	
		30	50	100	150	200	250	300	350	400	450		500
25A-LEY25		●	●	●	●	●	●	●	●	●	—	—	15 to 400
25A-LEY32		●	●	●	●	●	●	●	●	●	●	●	20 to 500

* Please consult with SMC for non-standard strokes as they are produced as special orders.

Solid state auto switches should be ordered separately. For details on auto switches, refer to page 681.

Applicable auto switches

D-M9N(V)-900, D-M9P(V)-900, D-M9B(V)-900
D-M9NW(V)-900, D-M9PW(V)-900, D-M9BW(V)-900

Electric Actuator Rod Type **25A-LEY Series**

AC Servo Motor

Size **25, 32**

Secondary Battery Compatible

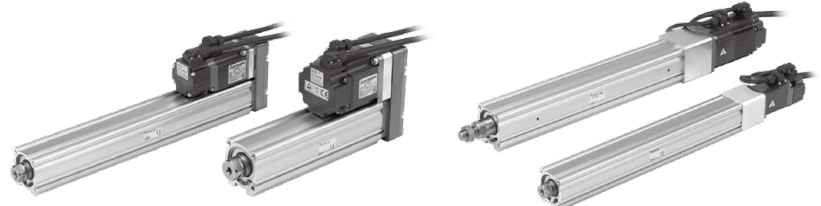

Motor mounting position:
Top/Parallel

Motor mounting position:
In-line

10 Cable type*1 *2

Nil	Without cable
S	Standard cable
R	Robotic cable (Flexible cable)

*1 The motor and encoder cables are included. (The lock cable is also included when the motor with lock option is selected.)

*2 Standard cable entry direction is
· Top/Parallel: (A) Axis side
· In-line: (B) Counter axis side

11 Cable length*1 [m]

Nil	Without cable
2	2
5	5
A	10

*1 The length of the encoder, motor, and lock cables are the same.

12 Driver type*1

	Compatible drivers	Power supply voltage [V]	UL-compliant
Nil	Without driver	—	—
A1	LECSA1-S□	100 to 120	●
A2	LECSA2-S□	200 to 230	●
B1	LECSB1-S□	100 to 120	—
	LECSB2-S□	200 to 230	—
B2	LECSB2-T□	200 to 240	●
	LECSB2-S□	200 to 230	—
C1	LECSC1-S□	100 to 120	—
C2	LECSC2-S□	200 to 230	—
	LECSC2-T□		●
S1	LECSS1-S□	100 to 120	—
S2	LECSS2-S□	200 to 230	—
	LECSS2-T□	200 to 240	●
N2	LECSN2-T□	200 to 240	●
92	LECSN2-T□-9	200 to 240	—
E2	LECSN2-T□-E	200 to 240	—
P2	LECSN2-T□-P	200 to 240	—

*1 When a driver type is selected, a cable is included. Select the cable type and cable length.

Example)

S2S2: Standard cable (2 m) + Driver (LECSS2)

S2: Standard cable (2 m)

Nil: Without cable and driver

* The 25A- series specifications and dimensions are the same as those of the standard model.

Compatible Drivers*1

Driver type	Pulse input type/ Positioning type	Pulse input type	CC-Link direct input type	SSCNET III type	Pulse input type	CC-Link direct input type	SSCNET III/H type	Network card type
Series	LECSA	LECSB	LECSC	LECSS	LECSB-T	LECSC-T	LECSS-T	LECSN-T
Number of point tables*2	Up to 7	—	Up to 255 (2 stations occupied)	—	Up to 255	Up to 255 (2 stations occupied)	—	Up to 255
Pulse input	○	○	—	—	○	—	—	—
Applicable network	—	—	CC-Link	SSCNET III	—	CC-Link	SSCNET III /H	PROFINET EtherCAT® EtherNet/IP™
Control encoder	Incremental 17-bit encoder	Absolute 18-bit encoder	Absolute 18-bit encoder	Absolute 18-bit encoder	Absolute 22-bit encoder	Absolute 18-bit encoder	Absolute 22-bit encoder	Absolute 22-bit encoder
Communication function	USB communication	USB communication, RS422 communication	USB communication	USB communication	USB communication, RS422 communication	USB communication	USB communication	USB communication
Power supply voltage [V]	100 to 120 VAC (50/60 Hz), 200 to 230 VAC (50/60 Hz)				200 to 240 VAC (50/60 Hz)	200 to 230 VAC (50/60 Hz)	200 to 240 VAC (50/60 Hz)	200 to 240 VAC (50/60 Hz)
Reference page	777							

*1 Copper and zinc materials are used for the motors, cables, controllers/drivers.

*2 The LECSN-T only supports PROFINET and EtherCAT®.

LEFS
LEFB

LEJS
LEJB

LEL

LEM

LEY
LEYG

LES
LESH

LEPY
LEPS

LER

LEH

LEY-X5

11-LEFS

11-LEJS

25A-

LEC□

JXC□

LECS□
LECS□-T

LECY□

Motorless

LAT3

Electric Actuator Rod Type

Secondary Battery Compatible

25A-LEY Series LEY25, 32

Size 25, 32



RoHS

LECS □ Series ▶ p. 677

Dust-tight/Water-jet-proof ▶ p. 625

Refer to page 312 for model selection.

How to Order

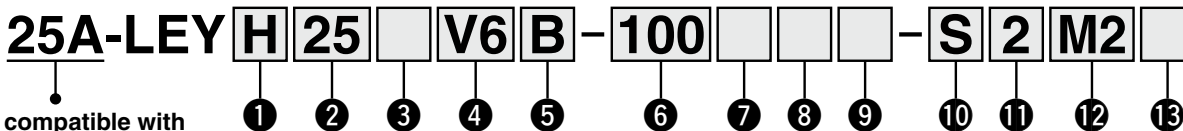

Series compatible with secondary batteries

1 Accuracy

Nil	Basic type
H	High-precision type

2 Size

25
32

3 Motor mounting position

Nil	Top mounting
R	Right side parallel
L	Left side parallel
D	In-line

4 Motor type

Symbol	Type	Output [W]	Size	Compatible drivers
V6*1	AC servo motor (Absolute encoder)	100	25	LECYM2-V5 LECYU2-V5
V7		200	32	LECYM2-V7 LECYU2-V7

*1 For motor type V6, the compatible driver part number suffix is V5.

5 Lead [mm]

Symbol	25A-LEY25	25A-LEY32*1
A	12	16 (20)
B	6	8 (10)
C	3	4 (5)

*1 The values shown in () are the leads for the size 32 top mounting, right/left side parallel types. (Equivalent leads which include the pulley ratio [1.25:1])

6 Stroke [mm]

30	30
to	to
500	500

* For details, refer to the applicable stroke table below.

7 Motor option

Nil	Without option
B	With lock*1

*1 When "With lock" is selected for the top mounting and right/left side parallel types, the motor body will stick out from the end of the body for size 25 with strokes of 30 mm or less. Check for interference with workpieces before selecting a model.

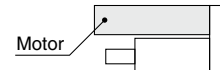

8 Rod end thread

Nil	Rod end female thread
M	Rod end male thread (1 rod end nut is included.)

9 Mounting*1

Symbol	Type	Motor mounting position	
		Top/Parallel	In-line
Nil	Ends tapped/ Body bottom tapped *2	●	●
L	Foot	●	—
F	Rod flange*2	●*4	●
G	Head flange*2	●*5	—
D	Double clevis*3	●	—

*1 The mounting bracket is shipped together with the product but does not come assembled.

*2 For the horizontal cantilever mounting of the rod flange, head flange, or ends tapped types, use the actuator within the following stroke range.
· LEY25: 200 mm or less · LEY32: 100 mm or less

*3 For the mounting of the double clevis type, use the actuator within the following stroke range.
· LEY25: 200 mm or less · LEY32: 200 mm or less

*4 The rod flange type is not available for the LEY25 with a 30 mm stroke and motor option "With lock."

*5 The head flange type is not available for the LEY32.

Mounting Bracket Part Nos. for the 25A- Series

Applicable size	Foot*1	Flange	Double clevis
25	25-LEY-L025	25-LEY-F025	25-LEY-D025
32	25-LEY-L032	25-LEY-F032	25-LEY-D032
Surface treatment	RAYDENT®	RAYDENT®	Coating (Size 16: Electroless nickel plating)

*1 When ordering foot brackets, order 2 pieces per actuator.

* Parts belonging to each bracket are as follows.

Foot, Flange: Body mounting bolt, Double clevis: Clevis pin, Type C retaining ring for axis, Body mounting bolt

Solid state auto switches should be ordered separately. For details on auto switches, refer to page 681.

Applicable auto switches

D-M9N(V)-900, D-M9P(V)-900, D-M9B(V)-900
D-M9NW(V)-900, D-M9PW(V)-900, D-M9BW(V)-900

Applicable Stroke Table

Model	Stroke [mm]	●: Standard											Manufacturable stroke range [mm]
		30	50	100	150	200	250	300	350	400	450	500	
25A-LEY25		●	●	●	●	●	●	●	●	●	—	—	15 to 400
25A-LEY32		●	●	●	●	●	●	●	●	●	●	●	20 to 500

* Please consult with SMC for non-standard strokes as they are produced as special orders.

Electric Actuator
Rod Type

25A-LEY Series

AC Servo Motor

Size 25, 32

Secondary Battery Compatible

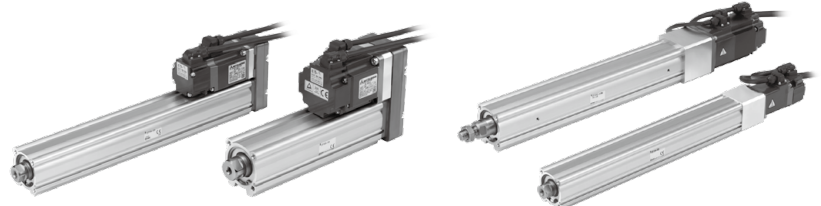

Motor mounting position:
Top/Parallel

Motor mounting position:
In-line

10 Cable type*1 *2

Nil	Without cable
S	Standard cable
R	Robotic cable (Flexible cable)

- *1 The motor and encoder cables are included. (The lock cable is also included when the motor with lock option is selected.)
- *2 Standard cable entry direction is
 - Top/Parallel: (A) Axis side
 - In-line: (B) Counter axis side

11 Cable length [m]*1

Nil	Without cable
3	3
5	5
A	10
C	20

- *1 The length of the motor and encoder cables are the same. (For with lock)

12 Driver type

	Compatible drivers	Power supply voltage [V]
Nil	Without driver	—
M2	LECYM2-V□	200 to 230
U2	LECYU2-V□	200 to 230

- * When a driver type is selected, a cable is included. Select the cable type and cable length.

13 I/O cable length [m]*1

Nil	Without cable
H	Without cable (Connector only)
1	1.5

- *1 When "Without driver" is selected for driver type, only "Nil: Without cable" can be selected. Refer to page 808 if I/O cable is required.

* The 25A- series specifications and dimensions are the same as those of the standard model.

Compatible Drivers

Driver type	MECHATROLINK-II type	MECHATROLINK-III type
Series	LECYM	LECYU
Applicable network	MECHATROLINK-II	MECHATROLINK-III
Control encoder	Absolute 20-bit encoder	
Communication device	USB communication, RS-422 communication	
Power supply voltage [V]	200 to 230 VAC (50/60 Hz)	
Reference page	801	

* Copper and zinc materials are used for the motors, cables, controllers/drivers.

LEFS
LEFB

LEJS
LEJB

LEL

LEM

LEY
LEYG

LES
LESH

LEPY
LEPS

LER

LEH

LEY-X5

11-LEFS

11-LEJS

25A-

LEC□

JXC□

LECS□
LECS□-T

LECY□

Motorless

LAT3

25A- Series

Applicable Auto Switches

Applicable Electric Actuator Series

Auto switches										Electric actuators			
Type	Special function	Electrical entry	Indicator light	Wiring (Output)	Electrical entry direction	Auto switch model	Lead wire length [m]				Pre-wired connector	LEJS	LEY
							0.5	1	3	5		40 to 63	16 to 40
							Nil	M	L	Z	SDPC	40 to 63	16 to 40
Solid state auto switch	—	Grommet	Yes	3-wire (NPN)	In-line	D-M9N-900	●	●	●	○	—	●	●
				3-wire (PNP)		D-M9P-900	●	●	●	○	—	●	●
				2-wire		D-M9B-900	●	●	●	○	—	●	●
				3-wire (NPN)	Perpendicular	D-M9NV-900	●	●	●	○	—	●	●
				3-wire (PNP)		D-M9PV-900	●	●	●	○	—	●	●
				2-wire		D-M9BV-900	●	●	●	○	—	●	●
	Diagnostic indication (2-color indicator)	Grommet	Yes	3-wire (NPN)	In-line	D-M9NW-900	●	●	●	○	—	●	●
				3-wire (PNP)		D-M9PW-900	●	●	●	○	—	●	●
				2-wire		D-M9BW-900	●	●	●	○	○	●	●
				3-wire (NPN)	Perpendicular	D-M9NWV-900	●	●	●	○	—	●	●
				3-wire (PNP)		D-M9PWV-900	●	●	●	○	—	●	●
				2-wire		D-M9BWV-900	●	●	●	○	○	●	●

* Solid state auto switches marked with "○" are produced upon receipt of order.

* Auto switches cannot be ordered with the actuator part number. They should be ordered separately. Please refer below for ordering. One each of the right-hand-type and the left-hand-type are shipped together with the actuator.

Ordering the Auto Switches

- Individual auto switch: D-M9BWL-900
(Place the order with the part number for auto switch shown in the table above.)
- * Lead wire length symbols: 0.5 m..... Nil (Example) M9NW
1 m..... M (Example) M9NWM
3 m..... L (Example) M9NWL
5 m..... Z (Example) M9NWZ



25A- Series Precautions

Be sure to read this before handling products.

Be sure to read the “Handling Precautions for SMC Products” (M-E03-3) and the “Operation Manual” before use.

Precautions

Caution

■ Change of material

For the 25A- series, there is a restriction on the use of copper and zinc as main components in the metal materials used. Keep in mind that the aluminum alloy, aluminum die cast, and some of the stainless steel materials contain traces of copper (Cu) and/or zinc (Zn) as an additive element.

However, copper is used in some parts—the coils of solenoid valves, the circuit boards, connector pins, and lead wires of electrical equipment and auto switches, and the motors, cables, and drivers of electric actuators—whose materials cannot be easily changed to alternative materials.

In addition, some magnets (including the surface treatment) contain copper (Cu) and/or zinc (Zn). However, due to their magnetic characteristics, it is impossible to use alternative materials.

■ Chemical environment

Refrain from using the products in such environments as exposed to chemicals. Otherwise, resin parts may deteriorate.

If you want SMC to test the products for the effects of chemicals attached to them, send the products back to SMC after thoroughly cleaning them.

Consult your SMC sales representative for further details.

- LEFS
- LEFB
- LEJS
- LEJB
- LEL
- LEM
- LEY
- LEYG
- LES
- LESH
- LEPY
- LEPS
- LER
- LEH
- LEY-X5
- 11-LEFS
- 11-LEJS
- 25A-
- LEC
- JXC
- LECS
- LECS-T
- LECY
- Motorless
- LAT3