

Vacuum Pad/Bellows Type

2.5-stage $\varnothing 20$, $\varnothing 32$, $\varnothing 50$ **5.5-stage** $\varnothing 20$, $\varnothing 25$, $\varnothing 32$, $\varnothing 40$, $\varnothing 50$

For the adsorption transfer of workpieces with flexible soft film packaging

Thin film skirt and special shaped ribs

Thin film skirt

Adapts to changes in soft packaging shape

Special ribs

Vacuum leakage reduced by improved sealing effect
Prevent the skirt from becoming caught

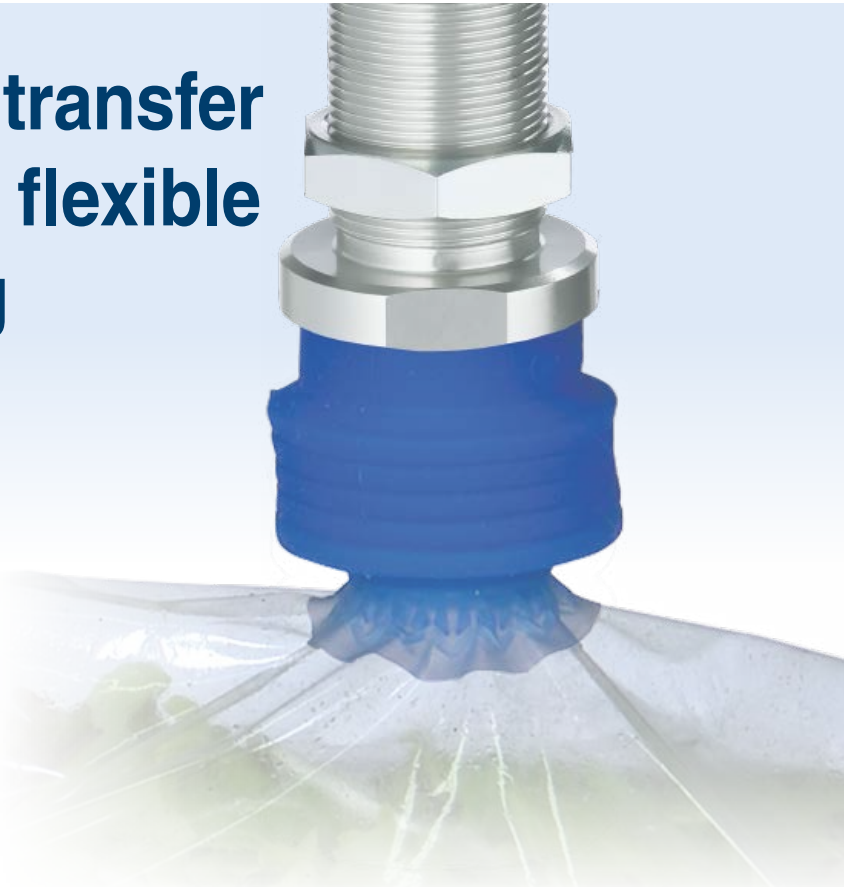
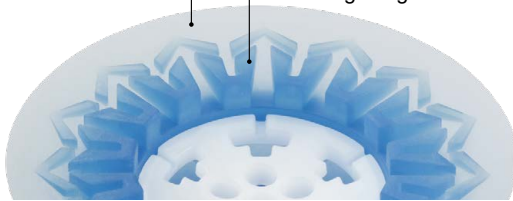

New Added: 2.5-stage bellows type

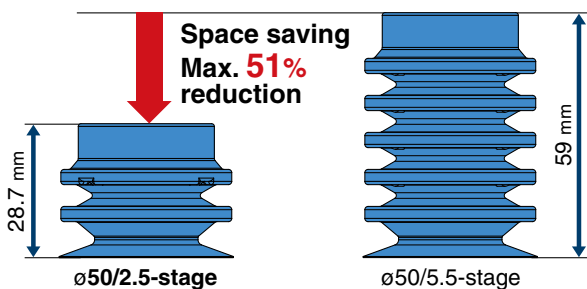

2.5-Stage Bellows Type



5.5-Stage Bellows Type



The pad and attachment are made of materials compliant with FDA (U.S. Food and Drug Administration) regulations as well as Food Sanitation Act standards.

Blue colored pad

Easy to distinguish the vacuum pad by color during contamination inspection

ZP3P-JT Series



CAT.ES100-128B

Unstable workpieces such as bagged liquid or powder can be transferred.

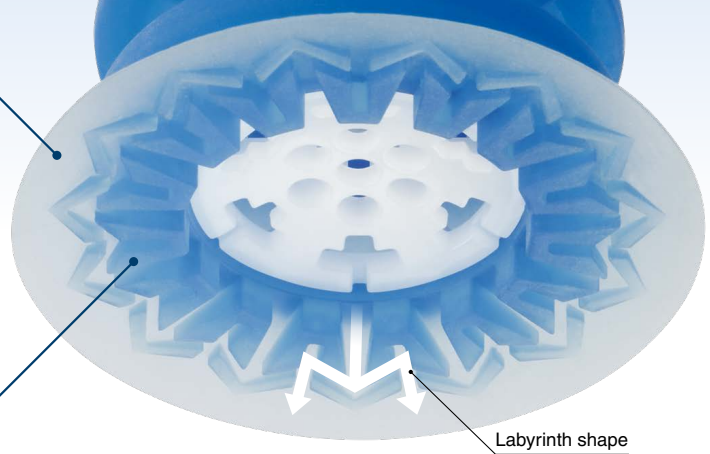

Application examples



Bellows Type

2.5-stage

Prevents the suction of foreign matter

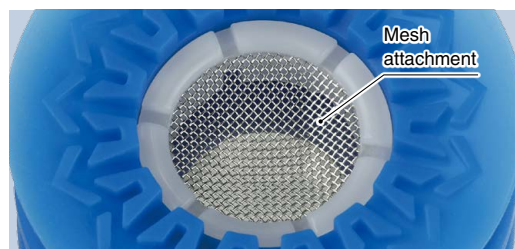

- Stainless steel mesh at suction port*1
- Prevents the intrusion of foreign matter into piping
 - Easy to check for clogging and easy to clean
 - Reduced suction filter element replacement frequency
- *1 The mesh will not fall off because it is integrally molded into the attachment.

Reduced deflection during transfer before adsorption

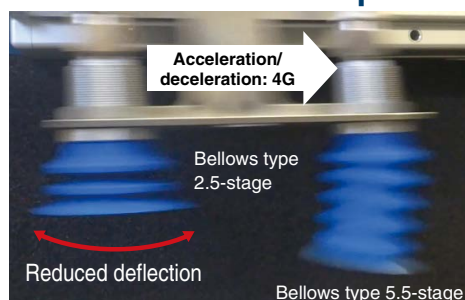

Expanded hole size

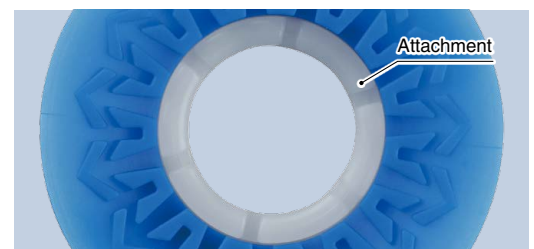

- Expanded hole size to ensure suction flow rate
 - Compatible with vacuum blower pumps
 - G3/8 and G1/2 standardized for the direct mounting/male thread type
- Min. opening hole size of the adapter: $\phi 11.5$ (Pad diameter: $\phi 32$ or $\phi 50$)



Bellows Type

5.5
-stage

Guide attachment

Deformation of the pad and deflection of the workpiece during adsorption transfer are reduced.

Guide attachment

With guide attachment
Small deformation and deflection

Without guide attachment
Large deformation and deflection

Transfer conditions
Pad diameter: $\phi 40$ [mm], Workpiece mass: 700 [g],
Supply pressure: -85 [kPa], Acceleration/Deceleration: 4 [G]

Before adsorption **Vacuum OFF** During adsorption **Vacuum ON**

Guide part

Flexible bag packaging

Multi-stage stroke

- Adaptable to changes in workpiece height and angle
- Reduced impact on the contents

Before adsorption **Vacuum OFF** During adsorption **Vacuum ON**

Stroke [mm]

$\phi 20$	10
$\phi 25$	12
$\phi 32$	16
$\phi 40$	20
$\phi 50$	26

* Achieved vacuum pressure: Reference at -85 [kPa]

Sticking is prevented.
Support ribs prevent the sticking of the bellows. This reduces returning failure when the vacuum pressure is turned off.

Support ribs (Projected)

Application examples Workpieces of varying heights can be adsorbed by the stroke.

Before adsorption **Vacuum OFF** During adsorption **Vacuum ON**

Vacuum ejector ZL Series

Downward adsorption

Uneven heights

Low-resilience bellows reduce the impact applied to the workpiece.

Standardized built-in One-touch fitting type

Reduced overall length, assembly, and labor time

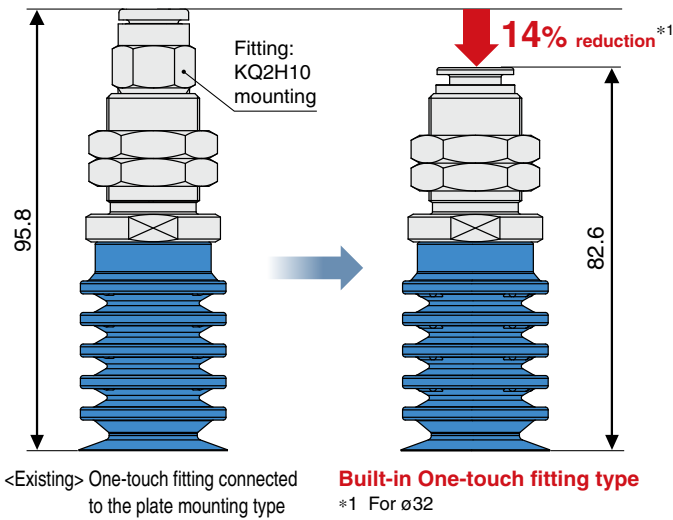

Applicable tubing O.D.

Bore size	Pad diameter
ø8	ø20
	ø25
	ø32
ø10	ø40
	ø50

* Same for both the 2.5-stage and the 5.5-stage



Variations

New Bellows Type 2.5-Stage		Connection thread	Vacuum inlet	Pad diameter			
				ø20	ø32	ø50	
Pad unit		—	—	●	●	●	
Direct mounting (Male thread)		Male thread	G1/8	*1	●	●	●
			G1/4	*1	●	●	●
			G3/8	*1	●	●	●
			G1/2	*1	●	●	●
Direct mounting (Female thread)		Female thread	G1/8	*1	●	●	●
			G1/4	*1	●	●	●
Plate mounting (Male/Female thread)		Male thread	M16 x 1	Rc, NPT1/8	●	●	●
			M20 x 1	Rc, NPT1/4	●	●	●
Plate mounting (Male thread/One-touch fitting)		Male thread	M16 x 1	ø8	●	●	●
			M20 x 1	ø10	●	●	●

*1 Same as the connection thread

Bellows Type 5.5-Stage		Connection thread	Vacuum inlet	Pad diameter				
				ø20	ø25	ø32	ø40	ø50
Pad unit		—	—	●	●	●	●	●
Direct mounting (Male thread)		Male thread	G1/8	●	●	○	○	○
			G1/4	*1	●	●	●	●
Direct mounting (Female thread)		Female thread	G1/8	*1	●	●	●	●
			G1/4	*1	●	●	●	●
Plate mounting (Male/Female thread)		Male thread	M16 x 1	Rc, NPT1/8	●	●	●	●
			M20 x 1	Rc, NPT1/4	●	●	●	●
Plate mounting (Male thread/One-touch fitting)		Male thread	M16 x 1	ø8	●	●	●	●
			M20 x 1	ø10	●	●	●	●

*1 Same as the connection thread ○ Newly added

CONTENTS

Vacuum Pad/Bellows Type *ZP3P-JT Series*

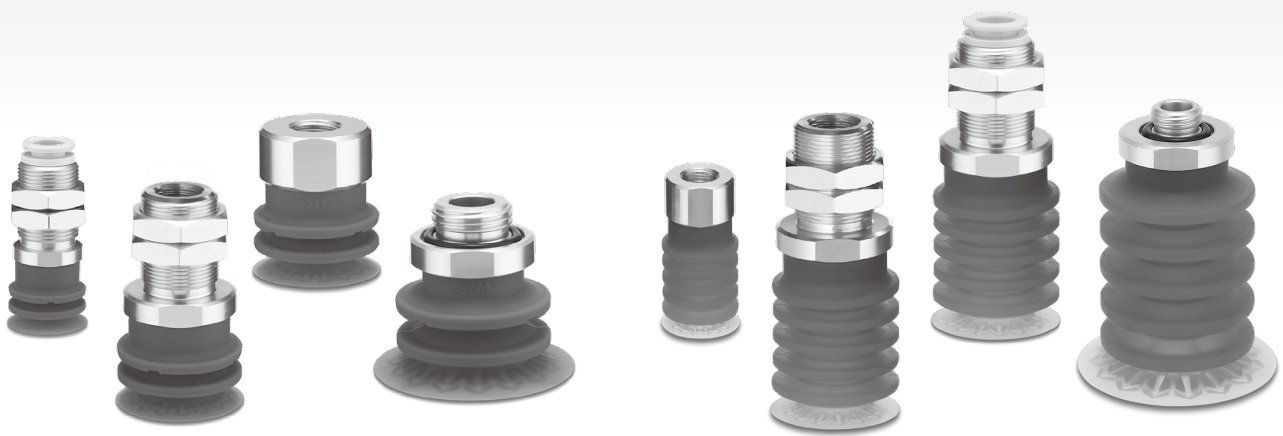

2.5-Stage/Bellows Type

5.5-Stage/Bellows Type

How to Order	p. 5	How to Order	p. 9
Specifications	p. 5	Specifications	p. 9
Dimensions/Models	p. 6	Dimensions/Models	p. 10
Construction	p. 8	Construction	p. 12
Mounting Bracket Assembly	p. 13		
Specific Product Precautions	p. 14		

2.5-Stage/Bellows Type

5.5-Stage/Bellows Type

Construction

Mounting Bracket Assembly

Specific Product Precautions



Vacuum Pad

2.5-Stage/Bellows Type

ZP3P-JT Series

How to Order

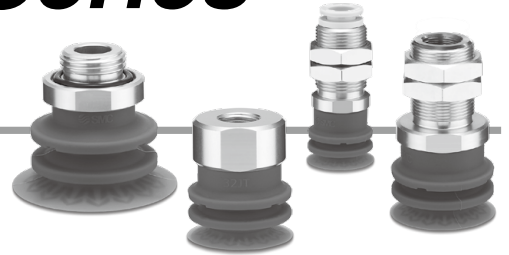

Pad unit ZP3P - **20** **JT** **2** **SF** - **W**

With adapter ZP3P - **T** **20** **JT** **2** **SF** - **W** - **AG01** - **□**

① Bellows type
2.5-stage • Silicone rubber

① Pad diameter

20	φ20
32	φ32
50	φ50

② Attachment

W	With attachment
WM	With mesh attachment

With adapter

③ Connection thread/④ Vacuum inlet

③ Connection thread				④ Vacuum inlet			Pad diameter [mm]	
Type	Thread	Symbol	Size	Thread	Symbol	Size	φ20	φ32, φ50
Direct mounting	Male thread	AG01	G1/8	—	Nil	—*1	●	●
		AG02	G1/4				●	●
		AG03	G3/8				●	●
		AG04	G1/2				—	●
	Female thread	BG01	G1/8	—	Nil	—*1	●	—
		BG02	G1/4				—	●
Plate mounting	Male thread	A16	M16 x 1	Female thread	B01	Rc1/8	●	—
					BN01	NPT1/8		
				One-touch fitting*2	08	φ8		
		A20	M20 x 1	Female thread	B02	Rc1/4	—	●
					BN02	NPT1/4		
				One-touch fitting*2	10	φ10		

*1 Use the connection thread.

*2 Built-in One-touch fitting type

Pad, adapter assembly, and mounting nuts are included but do not come assembled.

Specifications

Operating temperature range		-30 to 90°C*1
Pad	Material	Silicone rubber*2, *3
	Color	Blue
	Hardness (Shore A: ±5°)	40
Attachment	Material	Synthetic resin*2, *4/Stainless steel*5
	Color	White
	Mesh	Mesh: 60/Opening: 280 μm

*1 -5 to 60 [°C] for the vacuum inlet with One-touch fitting

*2 Compliant with FDA (U.S. Food and Drug Administration) regulation 21CFR§177.

*3 Compliant with the standards for "Rubber apparatus (excluding baby drinking apparatus) and containers/packaging" (D3) (Partial revision: Ministry of Health, Labour, and Welfare Notification No. 595, 2012) in Section 3 "Apparatus and Containers/Packaging" of the Food Sanitation Act, Article 18 "Specifications and Standards for Food and Food Additives, etc." (Ministry of Health and Welfare Notification No. 370, 1959)

*4 Compliant with the standards for "Synthetic resin apparatus and containers/packaging" (D2) in Section 3 "Apparatus and Containers/Packaging" of the Food Sanitation Act, Article 18 "Specifications and Standards for Food and Food Additives, etc." (Ministry of Health and Welfare Notification No. 370, 1959)

*5 Stainless steel included only for mesh attachment

Dimensions/Models

Pad unit

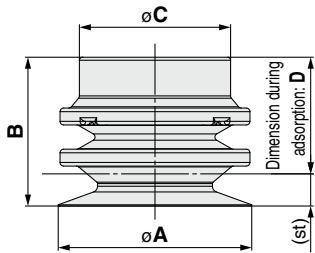

ZP3P - **20** JT2SF - **W**
① ②

	Model				A	B	C	D	(st)*1	Weight [g]
	① Pad dia.	Form	Number of bellows stages	Material						
ZP3P	20	JT	2	SF	W	WM	25	15.2	2.5	2.8
	32							20.6	4	8.3
	50							22.2	6.5	13.8

*1 (st) indicates achieved vacuum pressure: Reference at -85 [kPa]

With adapter Direct mounting type (Male thread)

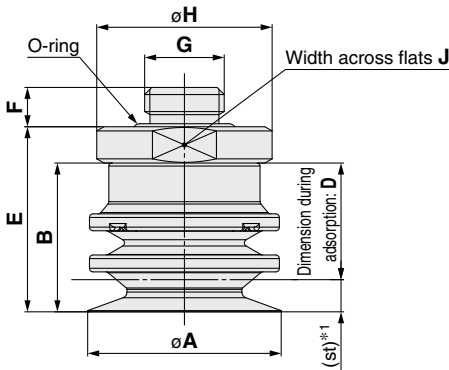

ZP3P - T **20** JT2SF - **W** - **AG01**
① ② ③

③ Connection thread (Male thread)

AG01	G1/8
AG02	G1/4
AG03	G3/8
AG04	G1/2

*1 Same dimension as the pad unit

	Vacuum inlet direction	Model				② Attachment	③ Connection thread	E	F	G	H	J	Weight [g]	Min. opening hole size of the adapter	
		① Pad dia.	Form	Number of bellows stages	Material										
ZP3P	T	20	JT	2	SF	W	WM	AG01	21.7	5.5	G1/8	18	17	6.5	ø5
								AG02	22.7	6.5	G1/4	23	21	9.4	ø6.2
		AG03						23.7	7.5	G3/8	29	27	15.9	ø6.2	
		AG01						30.6	5.5	G1/8	29	27	21.9	ø5.7	
		AG02							6.5	G1/4			21.6	ø8	
		AG03						7.5	G3/8	20.9	ø11.5				
	AG04	31.6	9	G1/2	32	30	27.8	ø11.5							
	50	AG01	34.7	5.5	G1/8	29	27	27.4	ø5.7						
		AG02		6.5	G1/4			27.1	ø8						
		AG03	7.5	G3/8	26.4	ø11.5									
		AG04	35.7	9	G1/2	32	30	33.3	ø11.5						

With adapter Direct mounting type (Female thread)

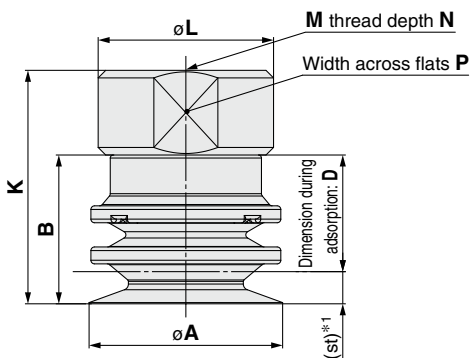

ZP3P - T **20** JT2SF - **W** - **BG01**
① ② ③

③ Connection thread (Female thread)

BG01	G1/8
BG02	G1/4

*1 Same dimension as the pad unit

	Vacuum inlet direction	Model				② Attachment	③ Connection thread	K	L	M	N	P	Weight [g]	Min. opening hole size of the adapter	
		① Pad dia.	Form	Number of bellows stages	Material										
ZP3P	T	20	JT	2	SF	W	WM	BG01	28.7	18	G1/8	7.4	17	9.2	ø5
		32						BG02	38.6	29	G1/4	11	27	31.1	ø8
		50						42.7	36.7						

2.5-Stage/Bellows Type

5.5-Stage/Bellows Type

Construction

Mounting Bracket Assembly

Specific Product Precautions

Dimensions/Models

With adapter Plate mounting type (Male/Female thread)

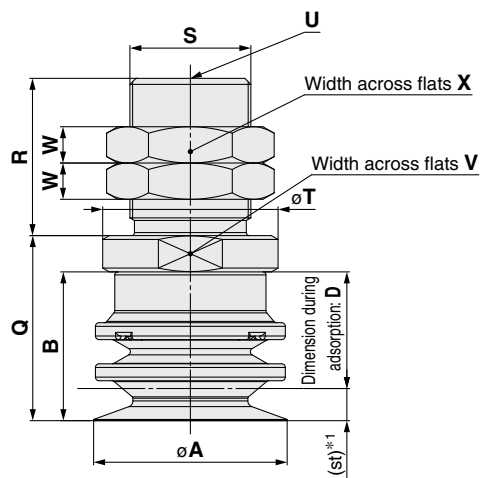

*1 Same dimension as the pad unit

ZP3P - T **20** JT2SF - **W** - **A16** - **B01**

①

②

③

④

Connection thread
(Male thread)

A16	M16 x 1
A20	M20 x 1

Vacuum inlet
(Female thread)

B01	Rc1/8
BN01	NPT1/8
B02	Rc1/4
BN02	NPT1/4

		Model										Q	R	S	T	U	V	W	X	Weight [g]	Min. opening hole size of the adapter		
Vacuum inlet direction	① Pad dia.	Form	Number of bellows stages	Material	② Attachment	③ Connection thread	④ Vacuum inlet																
ZP3P	T	20	JT	2	SF	WM	A16	B01	21.7	22	M16 x 1	18	Rc1/8	17	5	19	24	23.8	ø5				
		32					BN01	30.6	26	M20 x 1		29	Rc1/4							27	6	24	54.3
							BN02						NPT1/4										
50	B02	34.7	26	M20 x 1	29	Rc1/4	27	6	24	59.8													
	BN02					NPT1/4					59.7												

With adapter Plate mounting type (Male thread/One-touch fitting)

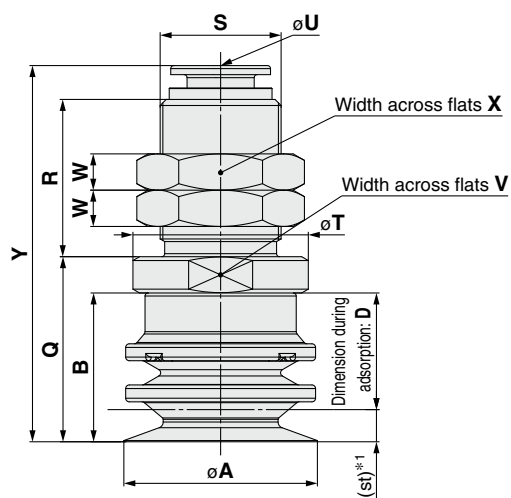

*1 Same dimension as the pad unit

ZP3P - T **20** JT2SF - **W** - **A16** - **08**

①

②

③

④

Connection thread
(Male thread)

A16	M16 x 1
A20	M20 x 1

Vacuum inlet
(One-touch fitting)

08	ø8
10	ø10

		Model										Q	R	S	T	U	V	W	X	Y	Weight [g]	Min. opening hole size of the adapter
Vacuum inlet direction	① Pad dia.	Form	Number of bellows stages	Material	② Attachment	③ Connection thread	④ Vacuum inlet															
ZP3P	T	20	JT	2	SF	WM	A16	08	21.7	22	M16 x 1	18	8	17	5	19	48.6	24.8	ø7.5			
		32					A20	10	30.6	26		M20 x 1	29	10	27	6	24	62		56.7		
																					62	56.7
50	32	A20	10	34.7	26	M20 x 1	29	10	27	6	24	66.1	62									

Vacuum Pad ZP3P-JT Series

2.5-Stage/Bellows Type

Construction

Direct mounting type (Male thread)
ZP3P-T□JT2SF-□-A□

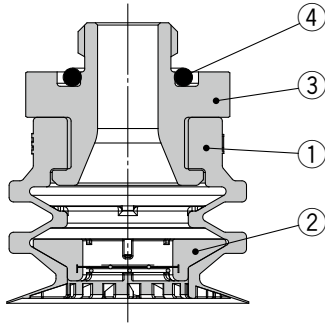

Direct mounting type (Female thread)
ZP3P-T□JT2SF-□-B□

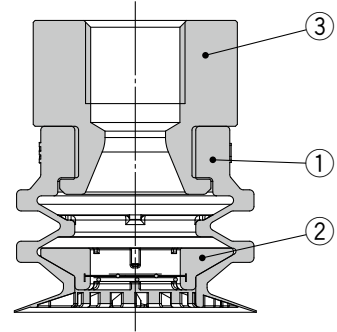

Plate mounting (Male/Female thread)
ZP3P-T□JT2SF-□-A□-B□

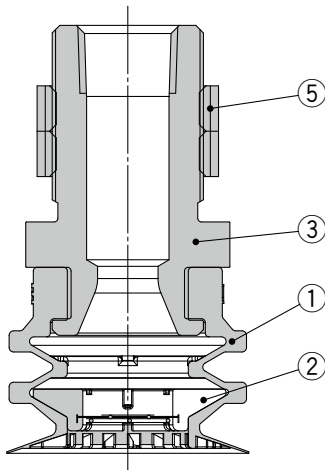
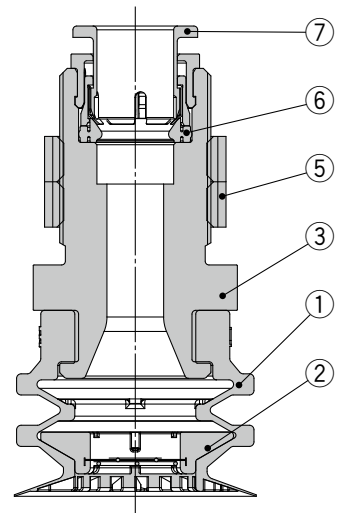

Plate mounting (Male thread/One-touch fitting)
ZP3P-T□JT2SF-□-A□-□



Component Parts

No.	Description	Material (Surface treatment)
1	Bellows pad	Silicone rubber
2	Attachment	Synthetic resin
	Mesh attachment	Synthetic resin/Stainless steel
3	Adapter	Aluminum alloy (Anodized)
4	O-ring	Silicone rubber
5	Mounting nut	Steel (Trivalent zinc chromated)
6	Seal	NBR
7	Cassette	—

Replacement Parts

Pad Unit (Without attachment)

Part number	Applicable pad dia.
ZP3P-20JT2SF	ø20
ZP3P-32JT2SF	ø32
ZP3P-50JT2SF	ø50

Attachment Unit

Part number	Applicable pad dia.
ZP3PW-20JT2	ø20
ZP3PW-32JT2	ø32
ZP3PW-50JT2	ø50

Mesh Attachment Unit

Part number	Applicable pad dia.
ZP3PWM-20JT2	ø20
ZP3PWM-32JT2	ø32
ZP3PWM-50JT2	ø50



Vacuum Pad

5.5-Stage/Bellows Type

ZP3P-JT Series

How to Order



Pad unit ZP3P - **20** JT 5 SF - WG

With adapter ZP3P - T **20** JT 5 SF - **AG01** - **3**

* With guide attachment

① Bellows type • 5.5-stage • Silicone rubber
 ② With guide attachment
 ③

① Pad diameter

20	ø20
25	ø25
32	ø32
40	ø40
50	ø50

With adapter

② Connection thread/③ Vacuum inlet

② Connection thread				③ Vacuum inlet			Pad diameter [mm]	
Type	Thread	Symbol	Size	Thread	Symbol	Size	ø20, ø25	ø32 to ø50
Direct mounting	Male thread	AG01	G1/8	—	Nil	—*1	●	●
		AG02	G1/4				—	●
	Female thread	BG01	G1/8				●	—
		BG02	G1/4				—	●
Plate mounting	Male thread	A16	M16 x 1	Female thread	B01	Rc1/8	●	—
				One-touch fitting*2	BN01	NPT1/8		
				●	08	ø8		
		A20	M20 x 1	Female thread	B02	Rc1/4	—	●
				One-touch fitting*2	BN02	NPT1/4		
				10	ø10			

*1 Use the connection thread.

*2 Built-in One-touch fitting type

Pad, adapter assembly, and mounting nuts are included but do not come assembled.

Specifications

Operating temperature range		-30 to 90°C*1
Pad	Material	Silicone rubber*2, *3
	Color	Blue
	Hardness (Shore A: ±5°)	40
Guide attachment	Material	Synthetic resin*2, *4
	Color	White

*1 -5 to 60 [°C] for the vacuum inlet with One-touch fitting

*2 Compliant with FDA (U.S. Food and Drug Administration) regulation 21CFR§177.

*3 Compliant with the standards for "Rubber apparatus (excluding baby drinking apparatus) and containers/packaging" (D3) (Partial revision: Ministry of Health, Labour, and Welfare Notification No. 595, 2012) in Section 3 "Apparatus and Containers/Packaging" of the Food Sanitation Act, Article 18 "Specifications and Standards for Food and Food Additives, etc." (Ministry of Health and Welfare Notification No. 370, 1959)

*4 Compliant with the standards for "Synthetic resin apparatus and containers/packaging" (D2) in Section 3 "Apparatus and Containers/Packaging" of the Food Sanitation Act, Article 18 "Specifications and Standards for Food and Food Additives, etc." (Ministry of Health and Welfare Notification No. 370, 1959)

Dimensions/Models

Pad unit

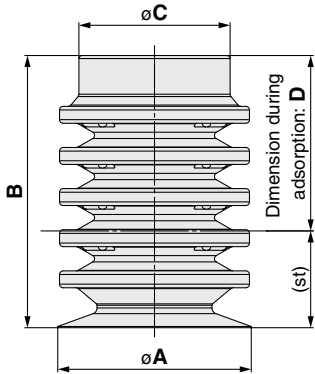

ZP3P - 20 JT5SF - WG

①

	Model				A	B	C	D	(st)*1	Weight [g]	
	① Pad dia.	Form	Number of bellows stages	Material							Attachment
ZP3P	20	JT	5	SF	WG	20	31.2	16	21.2	10	4.6
	25					35	23		12	6.3	
	32					45	25	29	16	14.8	
	40					51.5		31.5	20	20.3	
	50					59		33	26	26.9	

*1 (st) indicates achieved vacuum pressure: Reference at -85 [kPa]

With adapter Direct mounting type (Male thread)

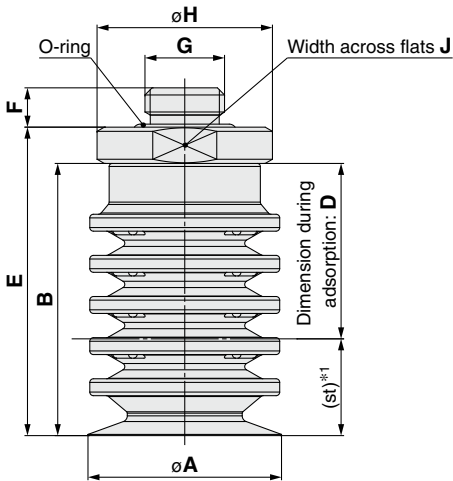

ZP3P - T 20 JT5SF - AG01

①

② Connection thread (Male thread)

AG01	G1/8
AG02	G1/4

	Model						E	F	G	H	J	Weight [g]	Min. opening hole size of the adapter	
	Vacuum inlet direction	① Pad dia.	Form	Number of bellows stages	Material	② Connection thread								
ZP3P	T	20	JT	5	SF	AG01	35.2	5.5	G1/8	18	17	8.3	ø5	
						AG01	39					10.1		
						AG01	51	5.5	G1/8			28.4		ø5.7
								AG02	6.5			G1/4		28.2
						AG01	57.5	5.5	G1/8			33.9		ø5.7
		AG02						6.5	G1/4	33.7	ø8			
		50				AG01	65	5.5	G1/8	40.5	ø5.7			
								AG02	6.5	G1/4	40.2	ø8		

*1 Same dimension as the pad unit

With adapter Direct mounting type (Female thread)

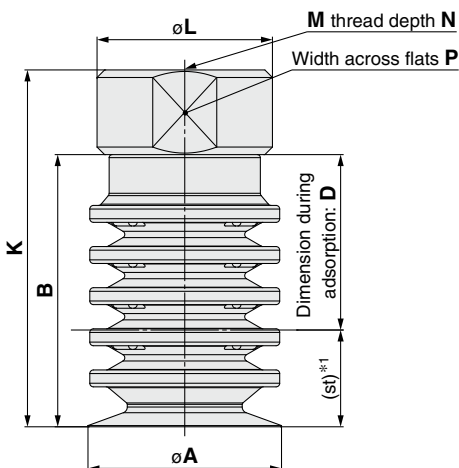

ZP3P - T 20 JT5SF - BG01

①

② Connection thread (Female thread)

BG01	G1/8
BG02	G1/4

	Model						K	L	M	N	P	Weight [g]	Min. opening hole size of the adapter
	Vacuum inlet direction	① Pad dia.	Form	Number of bellows stages	Material	② Connection thread							
ZP3P	T	20	JT	5	SF	BG01	42.2	18	G1/8	7.4	17	11	ø5
						BG01						46	
		BG02				59	29	G1/4	11	27	37.7	ø8	
											BG02		65.5
		73				49.8							

*1 Same dimension as the pad unit

2.5-Stage/Bellows Type

5.5-Stage/Bellows Type

Construction

Mounting Bracket Assembly

Specific Product Precautions

Dimensions/Models

With adapter Plate mounting type (Male/Female thread)

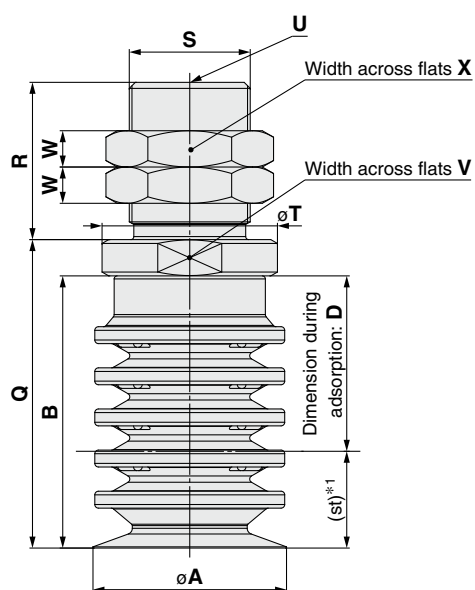

*1 Same dimension as the pad unit

ZP3P - T **20** JT5SF - **A16** - **B01**

①

② Connection thread
(Male thread)

A16	M16 x 1
A20	M20 x 1

③ Vacuum inlet
(Female thread)

B01	Rc1/8
BN01	NPT1/8
B02	Rc1/4
BN02	NPT1/4

		Model										Q	R	S	T	U	V	W	X	Weight [g]	Min. opening hole size of the adapter
Vacuum inlet direction	① Pad dia.	Form	Number of bellows stages	Material	② Connection thread	③ Vacuum inlet															
ZP3P	T	JT	5	SF	A16	B01	35.2	22	M16 x 1	18	Rc1/8	17	5	19	25.8	ø5					
						BN01	25.7				NPT1/8										
						B01	27.5				Rc1/8										
						BN01	27.4				NPT1/8										
						B02	60.8				Rc1/4										
	T	JT	5	SF	A20	B02	51	26	M20 x 1	29	NPT1/4	27	6	24	60.6	ø8					
						BN02	66.3				Rc1/4										
						B02	66.1				NPT1/4										
						BN02	72.9				Rc1/4										
						BN02	72.7				NPT1/4										

With adapter Plate mounting type (Male thread/One-touch fitting)

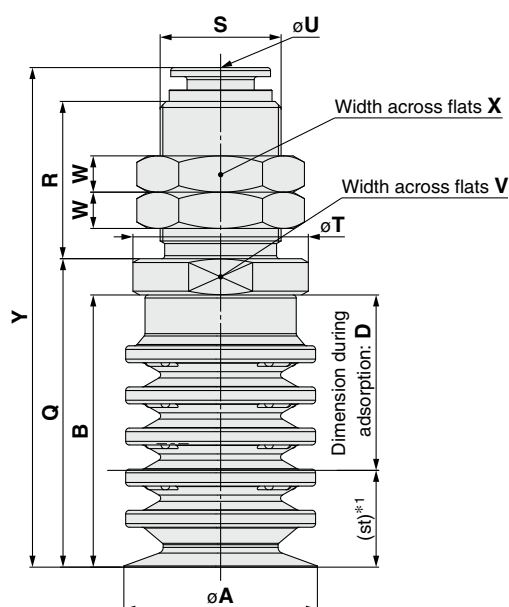

*1 Same dimension as the pad unit

ZP3P - T **20** JT5SF - **A16** - **08**

①

② Connection thread
(Male thread)

A16	M16 x 1
A20	M20 x 1

③ Vacuum inlet
(One-touch fitting)

08	ø8
10	ø10

		Model										Q	R	S	T	U	V	W	X	Y	Weight [g]	Min. opening hole size of the adapter
Vacuum inlet direction	① Pad dia.	Form	Number of bellows stages	Material	② Connection thread	③ Vacuum inlet																
ZP3P	T	JT	5	SF	A16	08	35.2	22	M16 x 1	18	8	17	5	19	62.1	ø5						
						BN08	28.4				65.9											
						B10	63.2				82.4											
						BN10	68.4				88.9											
						BN10	75.1				96.4											
	T	JT	5	SF	A20	10	57.5	26	M20 x 1	29	10	27	6	24	88.9	ø7.5						
						BN10	68.4				88.9											
						B10	68.4				88.9											
						BN10	75.1				96.4											
						BN10	75.1				96.4											

Vacuum Pad ZP3P-JT Series

5.5-Stage/Bellows Type

Construction

Direct mounting type (Male thread)

ZP3P-T□JT5SF-A□

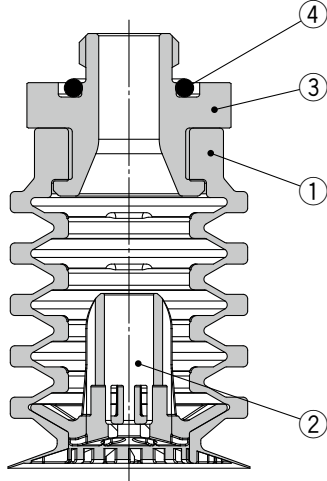

Direct mounting type (Female thread)

ZP3P-T□JT5SF-B□

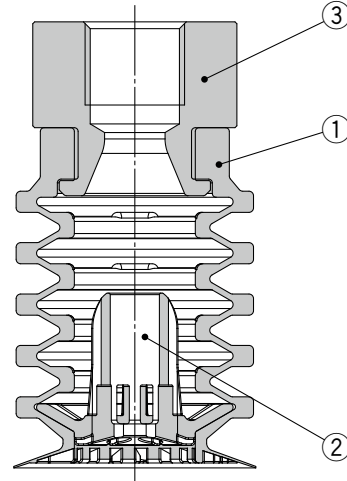

Plate mounting type (Male/Female thread)

ZP3P-T□JT5SF-A□-B□

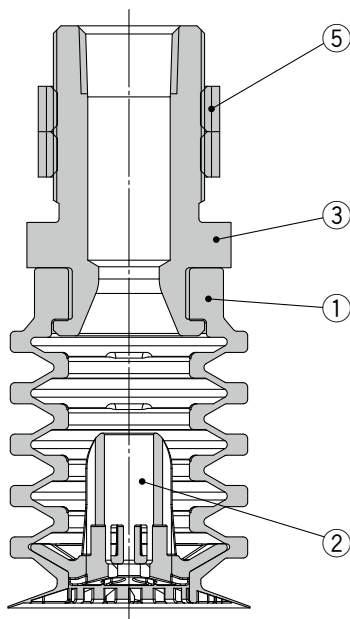
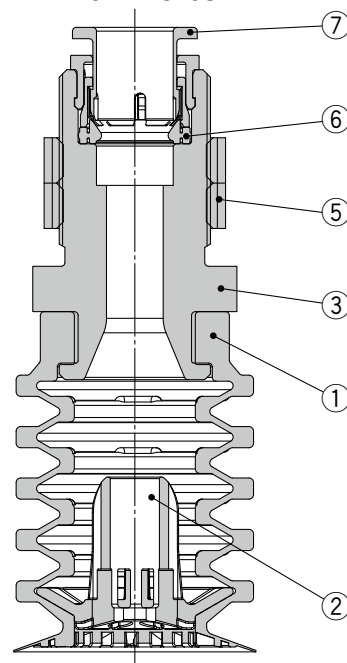

Plate mounting type (Male thread/One-touch fitting)

ZP3P-T□JT5SF-A□-□



Component Parts

No.	Description	Material (Surface treatment)
1	Bellows pad	Silicone rubber
2	Guide attachment	Synthetic resin
3	Adapter	Aluminum alloy (Anodized)
4	O-ring	Silicone rubber
5	Mounting nut	Steel (Trivalent zinc chromated)
6	Seal	NBR
7	Cassette	—

Replacement Parts

Pad Unit (Without guide attachment)

Part number	Applicable pad dia.
ZP3P-20JT5SF	ø20
ZP3P-25JT5SF	ø25
ZP3P-32JT5SF	ø32
ZP3P-40JT5SF	ø40
ZP3P-50JT5SF	ø50

Guide Attachment Unit

Part number	Applicable pad dia.
ZP3PWG-20JT5	ø20
ZP3PWG-25JT5	ø25
ZP3PWG-32JT5	ø32
ZP3PWG-40JT5	ø40
ZP3PWG-50JT5	ø50

2.5-Stage/Bellows Type

5.5-Stage/Bellows Type

Construction

Mounting Bracket Assembly

Specific Product Precautions

Vacuum Pad *ZP3P-JT Series* Mounting Bracket Assembly

Adapter Assembly: Direct Mounting Type

Product part number	<p>2.5-stage ZP3P - T ^① JT2SF - □ - ^②</p> <p>5.5-stage ZP3P - T ^① JT5SF - □ - ^②</p> <p>Pad diameter • Attachment • Connection thread (Male/Female thread)</p>
Component parts	<p>Male thread</p> <p>Female thread</p> <p>① Adapter (With O-ring)</p> <p>① Adapter</p>

Adapter	Type	Size	Symbol	① Pad diameter symbol				
				20	25	32	40	50
② Connection thread	Male thread	G1/8	AG01	ZP3PA-T1JT-AG01		ZP3PA-T2JT-AG01		
		G1/4	AG02	ZP3PA-T1JT-AG02*1		ZP3PA-T2JT-AG02		
		G3/8	AG03	ZP3PA-T1JT-AG03*1		ZP3PA-T2JT-AG03*1		
		G1/2	AG04	—		ZP3PA-T2JT-AG04*1		
Female thread	Female thread	G1/8	BG01	ZP3PA-T1JT-BG01		—		
		G1/4	BG02	—		ZP3PA-T2JT-BG02		

*1 2.5-stage bellows only

Adapter Assembly: Plate Mounting Type

Product part number	<p>2.5-stage ZP3P - T ^① JT2SF - □ - ^② - ^③</p> <p>5.5-stage ZP3P - T ^① JT5SF - □ - ^② - ^③</p> <p>Pad dia. • Attachment • Connection thread (Male thread) • Vacuum inlet</p>
Component parts	<p>Male/Female thread</p> <p>Male thread/One-touch fitting</p> <p>① Adapter (With mounting nut)</p> <p>① Adapter (With mounting nut)</p> <p>② Mounting nut</p> <p>② Mounting nut</p>

Adapter	Type	Size	Symbol	Type	Size	Symbol	① Pad diameter symbol					
							20	25	32	40	50	
② Connection thread	Male thread	M16 x 1	A16	③ Vacuum inlet	Female thread	Rc1/8	B01	ZP3PA-T1JT-A16-B01		—		
						NPT1/8	BN01	ZP3PA-T1JT-A16-BN01		—		
					One-touch fitting	ø8	08	ZP3PA-T1JT-A16-08		—		
						—		—		ZP3PA-T2JT-A20-B02		
					Female thread	Rc1/4	B02	—		ZP3PA-T2JT-A20-BN02		
						NPT1/4	BN02	—		ZP3PA-T2JT-A20-BN02		
One-touch fitting	ø10	10	—		ZP3PA-T2JT-A20-10							
③ Mounting nut (Single unit) (Sales unit: 10 pcs.)				M16 x 1			KQ08-P01A		—			
				M20 x 1			—		KQ10-P01A			



ZP3P-JT Series

Vacuum Pad/Specific Product Precautions

Be sure to read this before handling the products. Refer to the back cover for safety instructions. For vacuum equipment precautions, refer to the “Handling Precautions for SMC Products” and the “Operation Manual” on the SMC website: <https://www.smcworld.com>

Operating Precautions

⚠ Caution

1. When mounting the product, tighten with the tightening torque shown in the table below.

If excessive or insufficient tightening torque is applied, sealing failure or loose screws may result.

Direct mounting type
(Male thread)

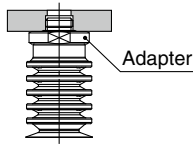

Product part number	Connection thread size	Proper tightening torque [N·m]
ZP3P-T□JT□-□-AG01	G1/8	3 to 5
ZP3P-T□JT□-□-AG02	G1/4	8 to 12
ZP3P-T□JT2-□-AG03	G3/8	15 to 20
ZP3P-T□JT2-□-AG04	G1/2	20 to 25

Direct mounting type
(Female thread)

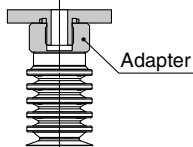

Product part number	Connection thread size	Proper tightening torque [N·m]
ZP3P-T□JT□-□-BG01	G1/8	3 to 5
ZP3P-T□JT□-□-BG02	G1/4	8 to 12

Plate mounting type
(Male/Female thread
(Male thread/One-touch fitting))

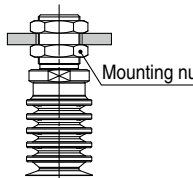

Product part number	Connection thread size	Proper tightening torque [N·m]
ZP3P-T□JT□-□-A16-□	M16 x 1	7 to 9
ZP3P-T□JT□-□-A20-□	M20 x 1	14 to 17

2. Depending on the achieved vacuum pressure, the theoretical lifting force may exceed the strength of the vacuum pad, deforming or breaking the pad.

The safety factor should be 16 times or more of the theoretical lifting force for horizontal lifting, and it should be 25 times or more for vertical lifting.

[Calculation of theoretical lifting force]

$$W = P \times S \times 0.1 \times \frac{1}{t}$$

W: Lifting force [N]

P: Vacuum pressure [kPa]

S: Pad area [cm²]

t: Safety factor Horizontal lifting: 16 or more
Vertical lifting: 25 or more

3. When a bagged workpiece is lifted, the skirt changes its shape according to the changing shape of the workpiece.

As the vacuum pad skirt changes its shape, the actual lifting force may be below the theoretical lifting force. Before use, please conduct testing with the customer's actual equipment.

4. Mount the attachment for use.

Without the attachment, the vacuum pad will be easily deformed, resulting in adsorption failure.

5. When the vacuum pad is pressed onto the workpiece, make sure it stays within the stroke range.

When the maximum stroke is exceeded, the guide attachment may contact the adapter, leading to malfunction.

6. When the attachment is inserted into the vacuum pad, the attachment may damage or break the skirt if it is pulled with excessive force as the skirt is very thin.

Vacuum pad damage or breakage may lead to adsorption failure.

7. When the achieved vacuum pressure is low (approx. -20 [kPa]), the vacuum pad does not completely operate its stroke.

When a 5.5-stage bellows is used, and vacuum pressure is approx. -20 [kPa], the guide function cannot be used effectively because the guide attachment cannot be pulled up into the adapter.

8. Use the product within the operating temperature range.

The heat resistant temperature of the attachment (made of synthetic resin) is 90°C.

Operate within the specified operating temperature range (-30 to 90°C).

For temperatures outside of the operating temperature range, contact your local SMC representative.

9. Do not interfere with the vacuum pad stroke with an external stopper.

The vacuum pad will become deformed, resulting in adsorption failure or breakage. In some cases, the workpiece will separate from the pad and fall.

10. Vacuum pads are consumable. Please replace them when cracks, wear, or deformation is confirmed during periodic maintenance.

11. Before use, please check the transfer conditions with the customer's actual equipment.

Products are confirmed as transferable under SMC's specific testing conditions in the table below, but these are not guaranteed values. The transfer ability varies depending on the workpiece material, the friction between the pad and workpiece, moment, wind, vibration, etc. Testing with the customer's actual equipment is necessary.

· SMC's Specific Testing Conditions (Reference)

Pad diameter	Number of bellows stages	Workpiece		Adsorption conditions		Horizontal transfer conditions	
		Material	Load [kg]	Ejector part number	Supply pressure [kPa]	Speed [mm/s]	Acceleration/Deceleration [G]
ø20	5.5-stage	Aluminum metalized film	0.17	ZH15D	-85	1000	2
ø25			0.27				3
ø32			0.5				3
ø40			0.7				4
ø50			1.1				4

* Adsorption is confirmed for 1 stroke, not for a back and forth or repeated operation.

12. When supplying vacuum release air, do so at a release flow rate of 110 L/min (ANR) or less. Failure to do so may result in damage to the vacuum pads.

2.5-Stage/Bellows Type

5.5-Stage/Bellows Type

Construction

Mounting Bracket Assembly

Specific Product Precautions

Safety Instructions

These safety instructions are intended to prevent hazardous situations and/or equipment damage. These instructions indicate the level of potential hazard with the labels of “**Caution**,” “**Warning**” or “**Danger**.” They are all important notes for safety and must be followed in addition to International Standards (ISO/IEC)*1), and other safety regulations.

 **Caution:** **Caution** indicates a hazard with a low level of risk which, if not avoided, could result in minor or moderate injury.

 **Warning:** **Warning** indicates a hazard with a medium level of risk which, if not avoided, could result in death or serious injury.

 **Danger :** **Danger** indicates a hazard with a high level of risk which, if not avoided, will result in death or serious injury.

*1) ISO 4414: Pneumatic fluid power – General rules relating to systems.
ISO 4413: Hydraulic fluid power – General rules relating to systems.
IEC 60204-1: Safety of machinery – Electrical equipment of machines.
(Part 1: General requirements)
ISO 10218-1: Manipulating industrial robots – Safety.
etc.

Warning

1. The compatibility of the product is the responsibility of the person who designs the equipment or decides its specifications.

Since the product specified here is used under various operating conditions, its compatibility with specific equipment must be decided by the person who designs the equipment or decides its specifications based on necessary analysis and test results. The expected performance and safety assurance of the equipment will be the responsibility of the person who has determined its compatibility with the product. This person should also continuously review all specifications of the product referring to its latest catalog information, with a view to giving due consideration to any possibility of equipment failure when configuring the equipment.

2. Only personnel with appropriate training should operate machinery and equipment.

The product specified here may become unsafe if handled incorrectly. The assembly, operation and maintenance of machines or equipment including our products must be performed by an operator who is appropriately trained and experienced.

3. Do not service or attempt to remove product and machinery/equipment until safety is confirmed.

1. The inspection and maintenance of machinery/equipment should only be performed after measures to prevent falling or runaway of the driven objects have been confirmed.
2. When the product is to be removed, confirm that the safety measures as mentioned above are implemented and the power from any appropriate source is cut, and read and understand the specific product precautions of all relevant products carefully.
3. Before machinery/equipment is restarted, take measures to prevent unexpected operation and malfunction.

4. Contact SMC beforehand and take special consideration of safety measures if the product is to be used in any of the following conditions.

1. Conditions and environments outside of the given specifications, or use outdoors or in a place exposed to direct sunlight.
2. Installation on equipment in conjunction with atomic energy, railways, air navigation, space, shipping, vehicles, military, medical treatment, combustion and recreation, or equipment in contact with food and beverages, emergency stop circuits, clutch and brake circuits in press applications, safety equipment or other applications unsuitable for the standard specifications described in the product catalog.
3. An application which could have negative effects on people, property, or animals requiring special safety analysis.
4. Use in an interlock circuit, which requires the provision of double interlock for possible failure by using a mechanical protective function, and periodical checks to confirm proper operation.

Caution

1. The product is provided for use in manufacturing industries.

The product herein described is basically provided for peaceful use in manufacturing industries.
If considering using the product in other industries, consult SMC beforehand and exchange specifications or a contract if necessary.
If anything is unclear, contact your nearest sales branch.

Limited warranty and Disclaimer/ Compliance Requirements

The product used is subject to the following “Limited warranty and Disclaimer” and “Compliance Requirements”.

Read and accept them before using the product.

Limited warranty and Disclaimer

1. The warranty period of the product is 1 year in service or 1.5 years after the product is delivered, whichever is first.*2)
Also, the product may have specified durability, running distance or replacement parts. Please consult your nearest sales branch.
2. For any failure or damage reported within the warranty period which is clearly our responsibility, a replacement product or necessary parts will be provided.
This limited warranty applies only to our product independently, and not to any other damage incurred due to the failure of the product.
3. Prior to using SMC products, please read and understand the warranty terms and disclaimers noted in the specified catalog for the particular products.

*2) Vacuum pads are excluded from this 1 year warranty.

A vacuum pad is a consumable part, so it is warranted for a year after it is delivered.
Also, even within the warranty period, the wear of a product due to the use of the vacuum pad or failure due to the deterioration of rubber material are not covered by the limited warranty.

Compliance Requirements

1. The use of SMC products with production equipment for the manufacture of weapons of mass destruction (WMD) or any other weapon is strictly prohibited.
2. The exports of SMC products or technology from one country to another are governed by the relevant security laws and regulations of the countries involved in the transaction. Prior to the shipment of a SMC product to another country, assure that all local rules governing that export are known and followed.

Caution

SMC products are not intended for use as instruments for legal metrology.

Measurement instruments that SMC manufactures or sells have not been qualified by type approval tests relevant to the metrology (measurement) laws of each country. Therefore, SMC products cannot be used for business or certification ordained by the metrology (measurement) laws of each country.

Revision History

Edition B	* The 2.5-stage bellows type has been added. * Plate mounting (One-touch fitting) has been added to the 5.5-stage bellows type. * Number of pages has been increased from 12 to 16.	YV
------------------	---	----

Safety Instructions

Be sure to read the “Handling Precautions for SMC Products” (M-E03-3) and “Operation Manual” before use.