

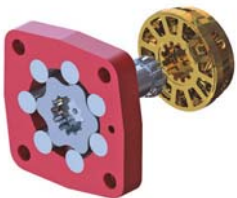

BREVINI®

Motion Systems

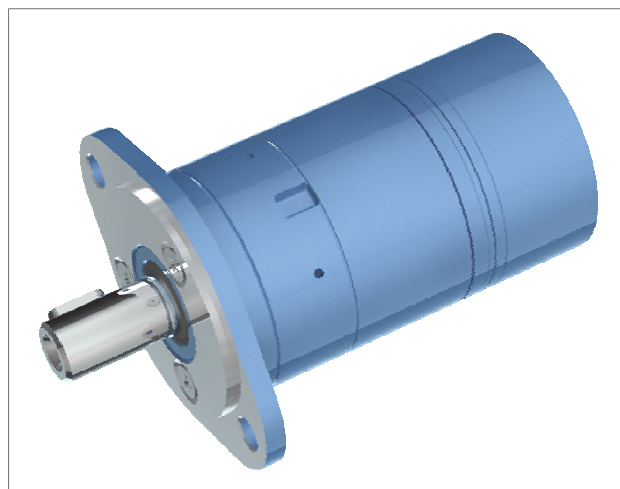

BGM

MOTORI ORBITALI

ORBITAL MOTORS

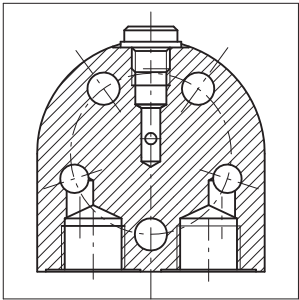
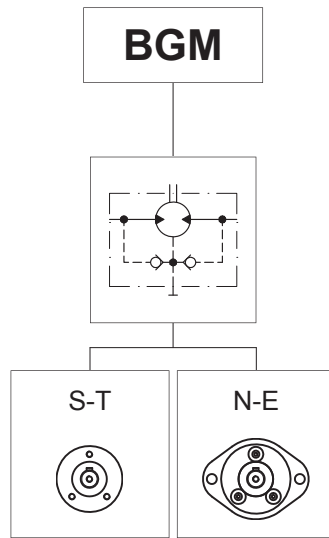

Alimentazione laterale.
Side ports configuration.

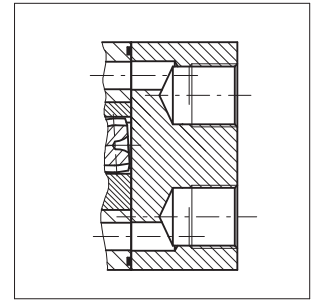

Alimentazione posteriore.
Rear ports configuration.

Buone capacità di carico radiale e assiale.
Very good side and axial load capacity.

Possibilità di alimentazione laterale o posteriore.
Rear and side ports option.

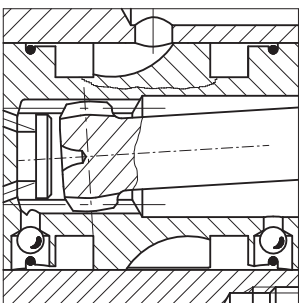

Distribuzione radiale e tolleranze ridotte al minimo per assicurare un drenaggio ridotto - Valvole interne di drenaggio.
Optimized spool valve design to minimize the leakage - built-in check valves.

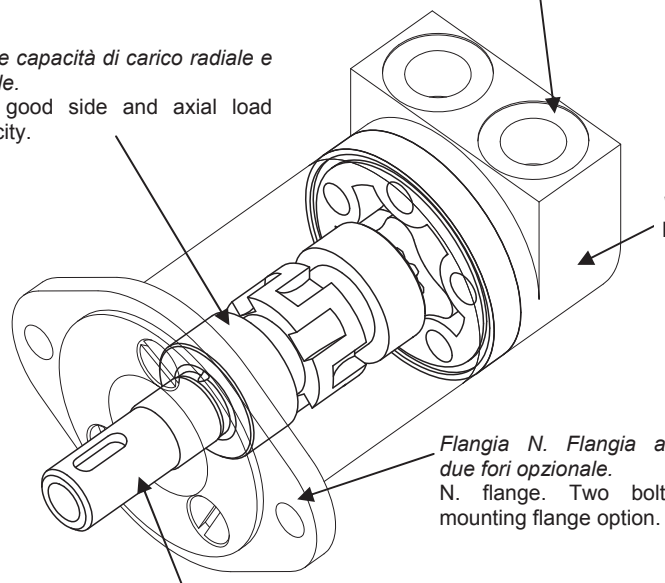

Valvole interne di drenaggio.
Built-in check valves.

Flangia N. Flangia a due fori opzionale.
N. flange. Two bolt mounting flange option.

Elevato rapporto coppia/peso e buona regolarità a basso numero di giri.
High torque/weight ratio and very good low speed performance.

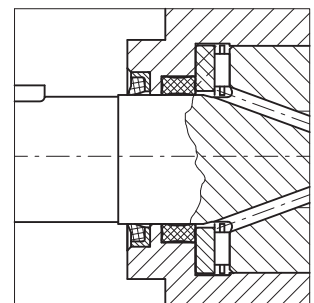

Parapolvere per proteggere la guarnizione di tenuta dell'albero dalle impurità.
Dust seal to protect the high pressure shaft seal.

CARATTERISTICHE TECNICHE TECHNICAL SPECIFICATIONS

Motore Motor	Cilindrata Displacement cm ³ /giro [in ³ /rev]	Max. pressione in ingresso Max. input pressure bar [psi]		Pressione diff. max. Max. differential pressure bar [psi]		Coppia max.* Max. torque*		Portata max. Max. flow		Velocità max. Max. speed		Potenza max. Max. power	
		Cont Int ¹⁾ Peak ²⁾	140 [2030] 175 [2537] 225 [3265]	Cont Int ¹⁾ Peak ²⁾	100 [1450] 140 [2030] 200 [2900]	Cont Int ¹⁾ Peak ²⁾	16 [11.7] 23 [16.9] 33 [24.3]	Cont Int ¹⁾	20 [5.28] 25 [6.60]	Cont Int ¹⁾	1550 1935	Cont Int ¹⁾	2.3 [3.08] 3.2 [4.28]
BGM 013	12.9 [0.78]	Cont Int ¹⁾ Peak ²⁾	140 [2030] 175 [2537] 225 [3265]	Cont Int ¹⁾ Peak ²⁾	100 [1450] 140 [2030] 200 [2900]	Cont Int ¹⁾ Peak ²⁾	16 [11.7] 23 [16.9] 33 [24.3]	Cont Int ¹⁾	20 [5.28] 25 [6.60]	Cont Int ¹⁾	1550 1935	Cont Int ¹⁾	2.3 [3.08] 3.2 [4.28]
BGM 020	20 [1.22]	Cont Int ¹⁾ Peak ²⁾	140 [2030] 175 [2537] 225 [3265]	Cont Int ¹⁾ Peak ²⁾	100 [1450] 140 [2030] 200 [2900]	Cont Int ¹⁾ Peak ²⁾	25 [18.4] 35 [25.7] 51 [37.5]	Cont Int ¹⁾	20 [5.28] 25 [6.60]	Cont Int ¹⁾	1000 1250	Cont Int ¹⁾	2.3 [3.08] 3.3 [4.42]
BGM 032	31.8 [1.93]	Cont Int ¹⁾ Peak ²⁾	140 [2030] 175 [2537] 225 [3265]	Cont Int ¹⁾ Peak ²⁾	100 [1450] 140 [2030] 160 [2320]	Cont Int ¹⁾ Peak ²⁾	39 [28.7] 54 [39.7] 60 [44.2]	Cont Int ¹⁾	20 [5.28] 25 [6.60]	Cont Int ¹⁾	625 785	Cont Int ¹⁾	2.3 [3.08] 2.8 [3.75]
BGM 040	40.1 [2.44]	Cont Int ¹⁾ Peak ²⁾	140 [2030] 175 [2537] 225 [3265]	Cont Int ¹⁾ Peak ²⁾	100 [1450] 140 [2030] 160 [2320]	Cont Int ¹⁾ Peak ²⁾	50 [36.8] 67 [49.3] 76 [56.0]	Cont Int ¹⁾	20 [5.28] 25 [6.60]	Cont Int ¹⁾	495 620	Cont Int ¹⁾	1.8 [2.41] 2.5 [3.35]
BGM 050	50 [3.05]	Cont Int ¹⁾ Peak ²⁾	140 [2030] 175 [2537] 225 [3265]	Cont Int ¹⁾ Peak ²⁾	80 [1160] 140 [2030] 160 [2320]	Cont Int ¹⁾ Peak ²⁾	49 [36.1] 83 [61.1] 94 [69.2]	Cont Int ¹⁾	20 [5.28] 25 [6.60]	Cont Int ¹⁾	400 500	Cont Int ¹⁾	1.8 [2.41] 2.4 [3.21]

¹⁾ Le condizioni intermittenti non devono durare più del 10% di ogni minuto / Intermittent duty must not exceed 10% each minute.

²⁾ Le condizioni di picco non devono durare più del 1% di ogni minuto / Peak duty must not exceed 1% each minute.

Motore Motor	Pressione max scar. con drenaggio Max return pressure with drain line bar [psi]		Pressione max avviamento a vuoto Max starting pressure with no load bar [psi]		Coppia minima di spunto Min starting torque Nm [lbf-ft]	
	Cont Int ¹⁾ Peak ²⁾	140 [2030] 175 [2537] 225 [3265]	Cont Int ¹⁾ Peak ²⁾	4 [58] 4 [58] 4 [58]	Cont Int ¹⁾	12 [8.8] 17 [12.5] 21 [15.4] 30 [22.1] 35 [25.7] 51 [37.5] 34 [25] 48 [35.3] 40 [29.4] 70 [51.5]
BGM 013	Cont Int ¹⁾ Peak ²⁾	140 [2030] 175 [2537] 225 [3265]	Cont Int ¹⁾ Peak ²⁾	4 [58] 4 [58] 4 [58]	Cont Int ¹⁾	12 [8.8] 17 [12.5]
BGM 020	Cont Int ¹⁾ Peak ²⁾	140 [2030] 175 [2537] 225 [3265]	Cont Int ¹⁾ Peak ²⁾	4 [58] 4 [58] 4 [58]	Cont Int ¹⁾	21 [15.4] 30 [22.1]
BGM 032	Cont Int ¹⁾ Peak ²⁾	140 [2030] 175 [2537] 225 [3265]	Cont Int ¹⁾ Peak ²⁾	4 [58] 4 [58] 4 [58]	Cont Int ¹⁾	35 [25.7] 51 [37.5]
BGM 040	Cont Int ¹⁾ Peak ²⁾	140 [2030] 175 [2537] 225 [3265]	Cont Int ¹⁾ Peak ²⁾	4 [58] 4 [58] 4 [58]	Cont Int ¹⁾	34 [25] 48 [35.3]
BGM 050	Cont Int ¹⁾ Peak ²⁾	140 [2030] 175 [2537] 225 [3265]	Cont Int ¹⁾ Peak ²⁾	4 [58] 4 [58] 4 [58]	Cont Int ¹⁾	40 [29.4] 70 [51.5]

MASSIMA PRESSIONE AMMESSA SULLA GUARNIZIONE ALBERO MAX PERMISSIBLE SHAFT SEAL PRESSURE

Pressione massima di scarico senza drenaggio o massima pressione nella linea di drenaggio. I motori sono forniti nella versione con guarnizioni standard (diagramma Standard) o nella versione con guarnizioni ad alta pressione (diagramma HPS). Per condizioni di pressione e velocità non contemplate dal presente grafico si consiglia di contattare Dana Brevini.

Max. return pressure without drain line or max. pressure in the drain line. Motor are supplied in standard seal version (Standard chart) or in HPS seal version (HPS chart). For pressure and speeds not showed in the curve below, please contact Dana Brevini.

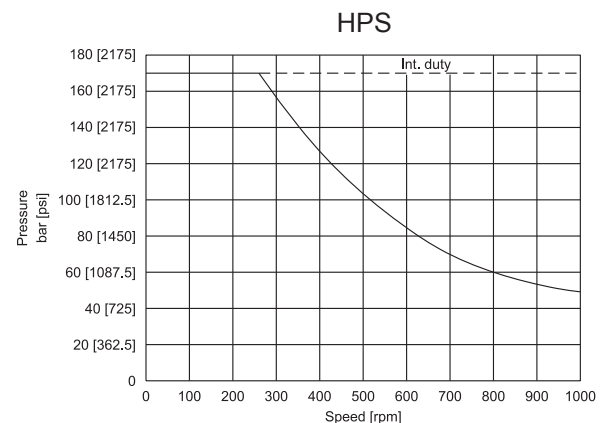
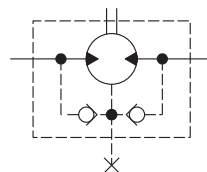
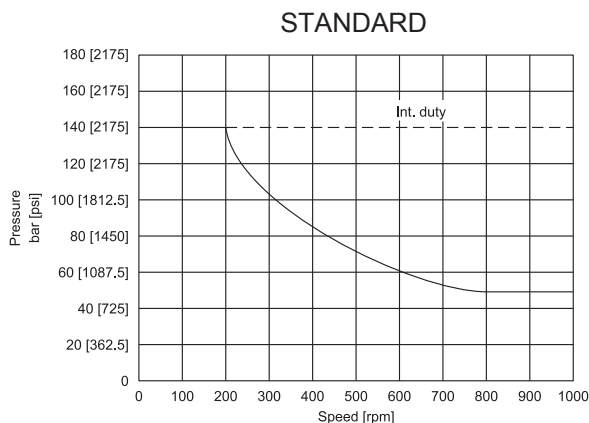

PERDITE DI CARICO PER ATTRAVERSAMENTO PRESSURE LOSS

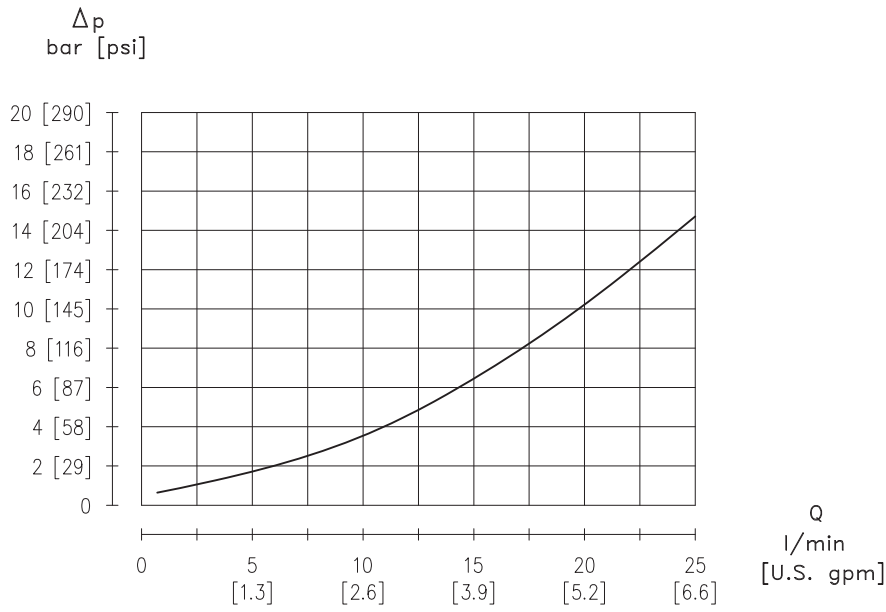

Il diagramma è stato ottenuto con prove eseguite su un numero significativo di motori, utilizzando un'olio avente una viscosità cinematica di 37 cSt alla temperatura di 45° C.

Diagram according to tests done with a relevant number of motors and using hydraulic oil with kinematic viscosity of 37 cSt at 45° C temperature.

CODICE DI ORDINAZIONE ORDERING CODE

Le seguenti lettere o numeri del codice, sono state sviluppate per identificare tutte le configurazioni possibili dei motori BGM. Usare il seguente modulo per identificare le caratteristiche desiderate. **Tutte le lettere o numeri del codice devono comparire in fase d'ordine.** Si consiglia di leggere attentamente il catalogo prima di iniziare la compilazione del codice di ordinazione.

The following alphanumeric digits system has been developed to identify all of the configuration options for the BGM motors. Use the model code below to specify the desired features. **All alphanumeric digits system of the code must be present when ordering.** We recommend to carefully read the catalogue before filling the ordering code.

CODICE PRODOTTO / MODEL CODE

1	2	3	4	5	6	7	8	9	10	11	12

1 - SERIE / SERIES

BGM	Motore orbitale Orbital motor
------------	----------------------------------

2 - CILINDRATA / DISPLACEMENT

013	13 cm ³ /giro [0.793 in ³ /rev]
020	20 cm ³ /giro [1.22 in ³ /rev]
032	32 cm ³ /giro [1.952 in ³ /rev]
040	40 cm ³ /giro [2.44 in ³ /rev]
050	50 cm ³ /giro [3.05 in ³ /rev]

3 - VERSIONE / VERSION

FR0	Versione Base Standard Version
SP1	Versione SP1 SP1 Version
FRQ	Versione Q Q Version

4 - FLANGIA / MOUNT FLANGE

S	3 fori M6 - Ø31.5mm 3 bolts M6 - Ø31.5mm [Ø 1.240 in]	STANDARD
T	3 fori 1/4 - 28 UNF - Ø31.5mm 3 bolts 1/4 - 28 UNF - Ø31.5mm [Ø 1.240 in]	
N	2 fori - Ø63mm (In abbinamento con flangia S) 2 bolts - Ø63mm [Ø 2.480 in] - (combination with S flange)	
E	2 fori - Ø63mm - (In abbinamento con flangia T) 2 bolts - Ø63mm [Ø 2.480 in] - (combination with T flange)	

5 - ESTREMITÀ ALBERO / SHAFT END

CL160	Cilindrico Ø16 mm Parallel keyed Ø16 mm [0.629 in]
SC160	Scanalato profilo B17x14 DIN5482 B17x14 DIN5482 Splined
CL158	Cilindrico Ø15.88 mm Parallel keyed Ø15.88 mm [Ø0.625 in]
CS158	Cilindrico crosshole Ø15.88 mm Parallel crosshole Ø15.88 mm [Ø0.625 in]

1	2	3	4	5	6	7	8	9	10	11	12

6 - ATTACCO / MAIN PORT

		VERSIONE / VERSION		
		FR0	SP1	FRQ
M06	Attacchi 3/8 G (BSPP) 3/8 G (BSPP) Main Ports	STANDARD	•	•
S06	Attacchi 9/16 - 18 UNF 9/16 - 18 UNF Main Ports		•	/

• Disponibile - Available / Non Disponibile - Not Available

7 - TENUTA / SEAL

N	NBR
---	-----

8 - VALVOLA / VALVE

		ATTACCO / MAIN PORT	
		M06	S06
XXXX	Non Richieste Not Required	•	•
M061	Valvola di massima pressione VAF 06 - D Pressure relief valve VAF 06 - D	•	/

• Disponibile - Available / Non Disponibile - Not Available

9 - CARATTERISTICA VALVOLA / VALVE FEATURE

		VALVOLA / VALVE	
		XXXX	M061
000	Caratteristica non necessaria Feature not necessary	•	/
030	Non Tarata (Campo Taratura 50+150 bar) Not Set 50+150 bar [725 to 2175 psi]	/	•

• Disponibile - Available / Non Disponibile - Not Available

10 - OPZIONE / OPTION

XX	Nessuna Opzione None
----	-------------------------

11 - CARATTERISTICA VERSIONE / VERSION FEATURE

		FLANGIA / FLANGE			
		S	T	N	E
QDG	Versione QUAD-RING con Drenaggio posteriore 1/8 G (BSPP) QUAD-RING version with Rear drain 1/8 G (BSPP)	•	•	•	•
HPS	Guarnizione alta pressione High Pressure Seal	•	•	•	•
TES	Tachimetro TAC-E (con predisposizione per sensore) - Senso di rotazione impiego SX (Standard) TAC-E Tachometer (with sensor arrangement) - CCW suitable direction of rotation (Standard)	•	/	•	/
TED	Tachimetro TAC-E (con predisposizione per sensore) - Senso di rotazione impiego DX (Opzionale) TAC-E Tachometer (with sensor arrangement) - CW suitable direction of rotation (Optional)	•	/	•	/

• Disponibile - Available / Non Disponibile - Not Available

12 - VERNICIATURA / PAINTING

XX	Non Verniciato Not Painted
01	Verniciato Nero RAL 9005 Black Painted RAL 9005
22	Verniciato Grigio RAL 7035 Grey Painted RAL 7035

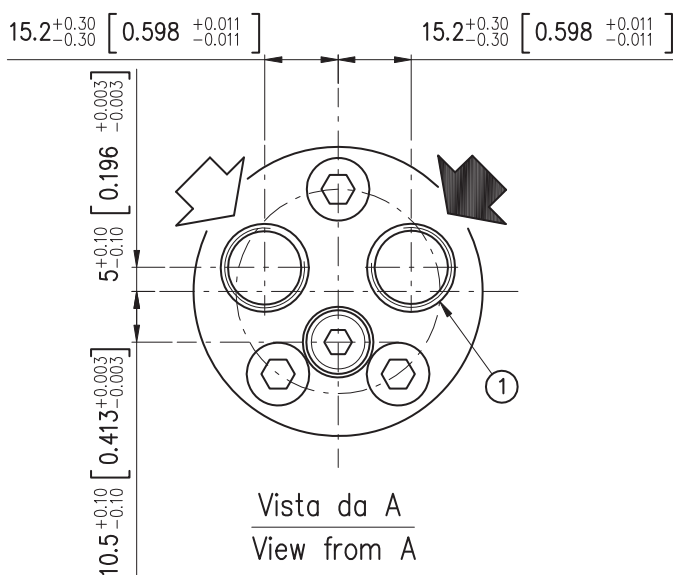
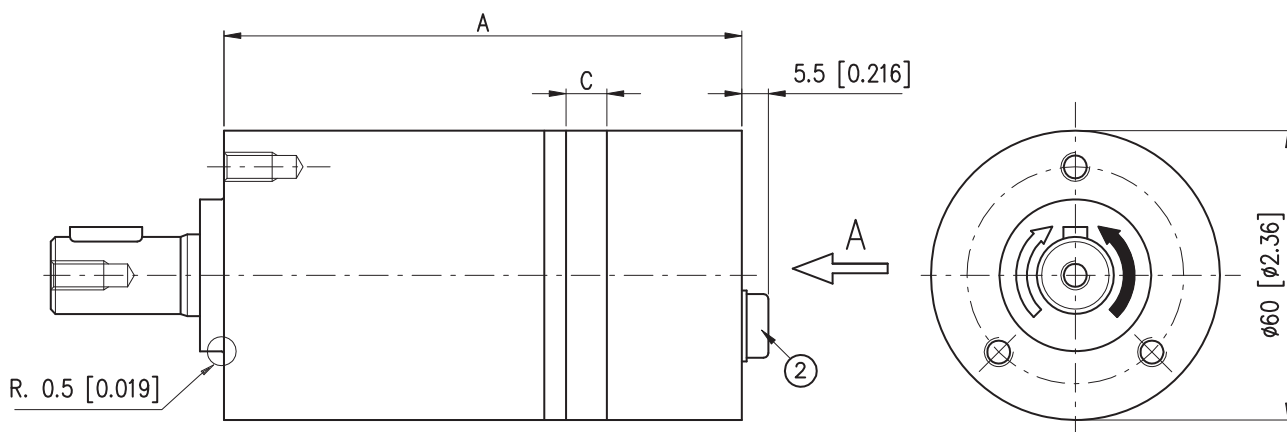

ATTACCHI M06 / M06 MAIN PORTS

- 1) N.2 Fori di alimentazione 3/8 G (BSPP) prof. filetto 12mm
N.2 3/8 G (BSPP) main ports thread depth [0.472 in]
- 2) Drenaggio motore 1/8 G (BSPP) prof. filetto 9mm
1/8 G (BSPP) drain port thread depth [0.354 in]

ATTACCHI S06 / S06 MAIN PORTS

- 1) N.2 Fori di alimentazione 9/16"-18 UNF prof. filetto 13mm
N.2 9/16"-18 UNF main ports thread depth [0.511 in]
- 2) Drenaggio motore 7/16"-20 UNF prof. filetto 12mm
7/16"-20 UNF drain port thread depth [0.472 in]

		BGM 013	BGM 020	BGM 032	BGM 040	BGM 050
A	mm [in]	104.5 [4.11]	107.5 [4.23]	112.5 [4.42]	116 [4.56]	120 [4.72]
B	mm [in]	-	-	-	-	-
C	mm [in]	5.5 [0.216]	8.5 [0.334]	13.5 [0.531]	17 [0.66]	21 [0.82]
Pesi - Weight	kg [lb]	2 [4.4]	2.06 [4.5]	2.15 [4.7]	2.2 [4.8]	2.25 [4.9]

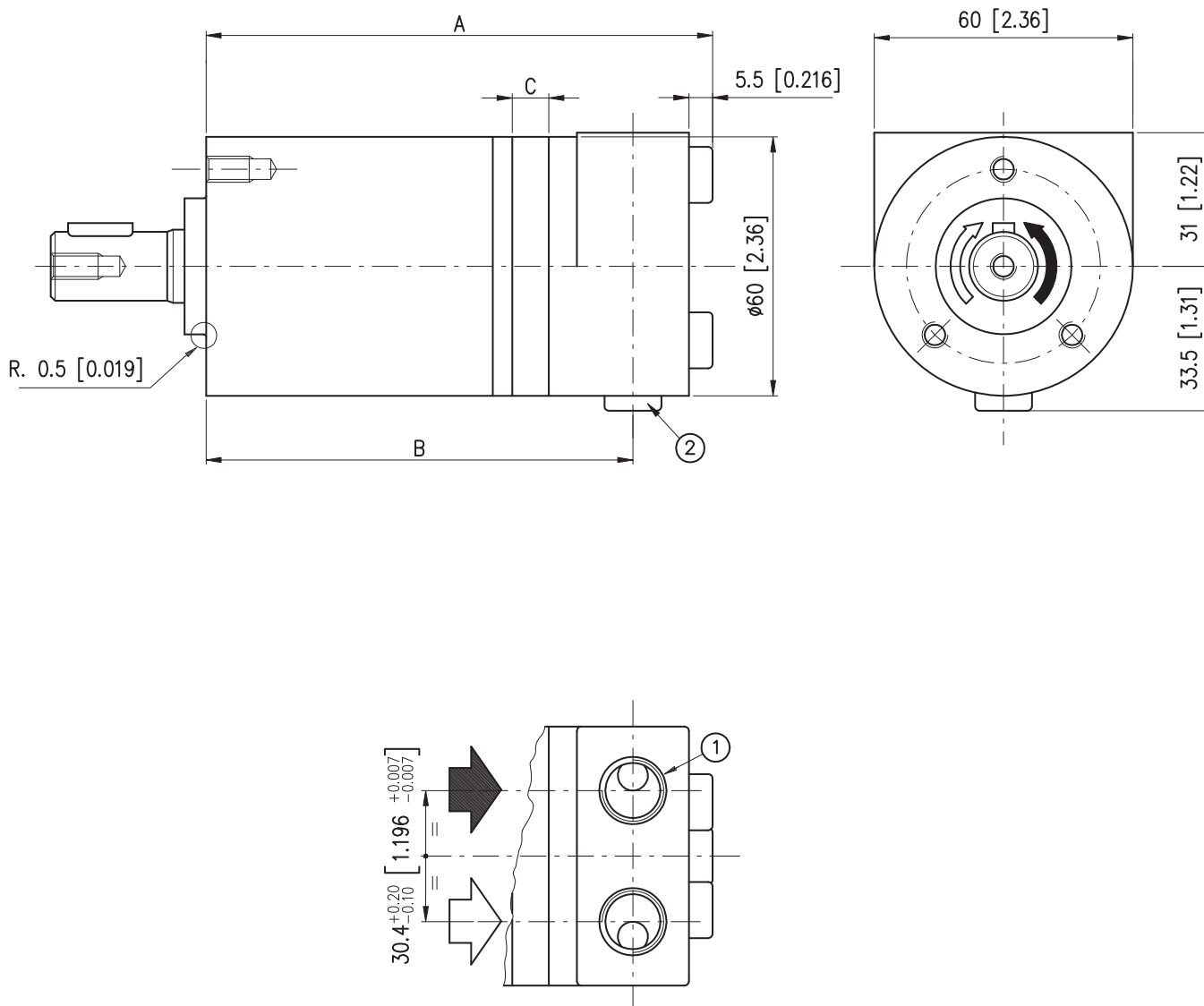

ATTACCHI M06 / M06 MAIN PORTS

- 1) N.2 Fori di alimentazione 3/8 G (BSPP) prof. filetto 12mm
N.2 3/8 G (BSPP) main ports thread depth [0.472 in]
- 2) Drenaggio motore 1/8 G (BSPP) prof. filetto 10mm
1/8 G (BSPP) drain port thread depth [0.393 in]

ATTACCHI S06 / S06 MAIN PORTS

- 1) N.2 Fori di alimentazione 9/16"-18 UNF prof. filetto 13mm
N.2 9/16"-18 UNF main ports thread depth [0.511 in]
- 2) Drenaggio motore 7/16"-20 UNF prof. filetto 12mm
7/16"-20 UNF drain port thread depth [0.472 in]

		BGM 013	BGM 020	BGM 032	BGM 040	BGM 050
A	mm [in]	113.8 [4.48]	116.8 [4.59]	121.8 [4.79]	125.3 [4.93]	129.3 [5.09]
B	mm [in]	95.3 [3.75]	98.3 [3.87]	103.3 [4.06]	106.8 [4.20]	110.8 [4.36]
C	mm [in]	5.5 [0.216]	8.5 [0.334]	13.5 [0.531]	17 [0.66]	21 [0.82]
Pesi - Weight	kg [lb]	2.1 [4.6]	2.16 [4.7]	2.25 [4.9]	2.3 [5]	2.35 [5.1]

Flangia S Flange

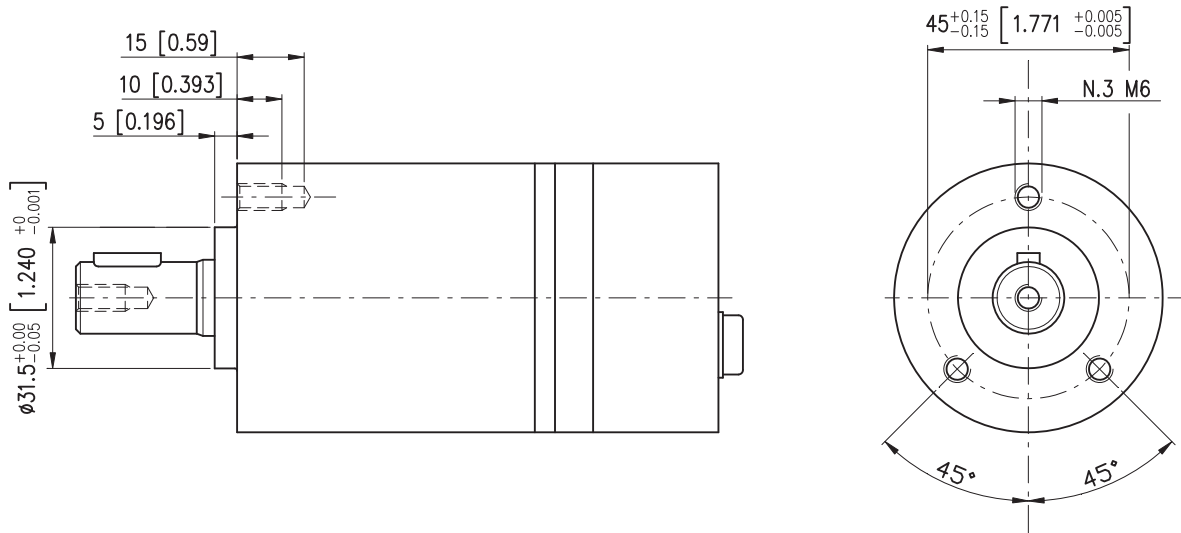

Flangia T Flange

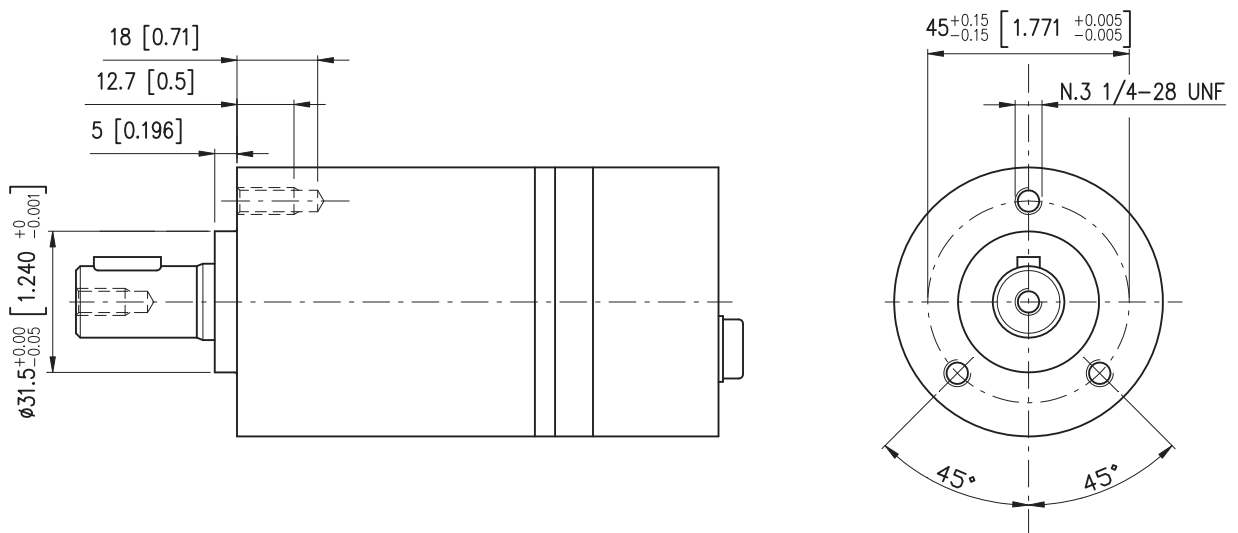

Flangia N - E Flange

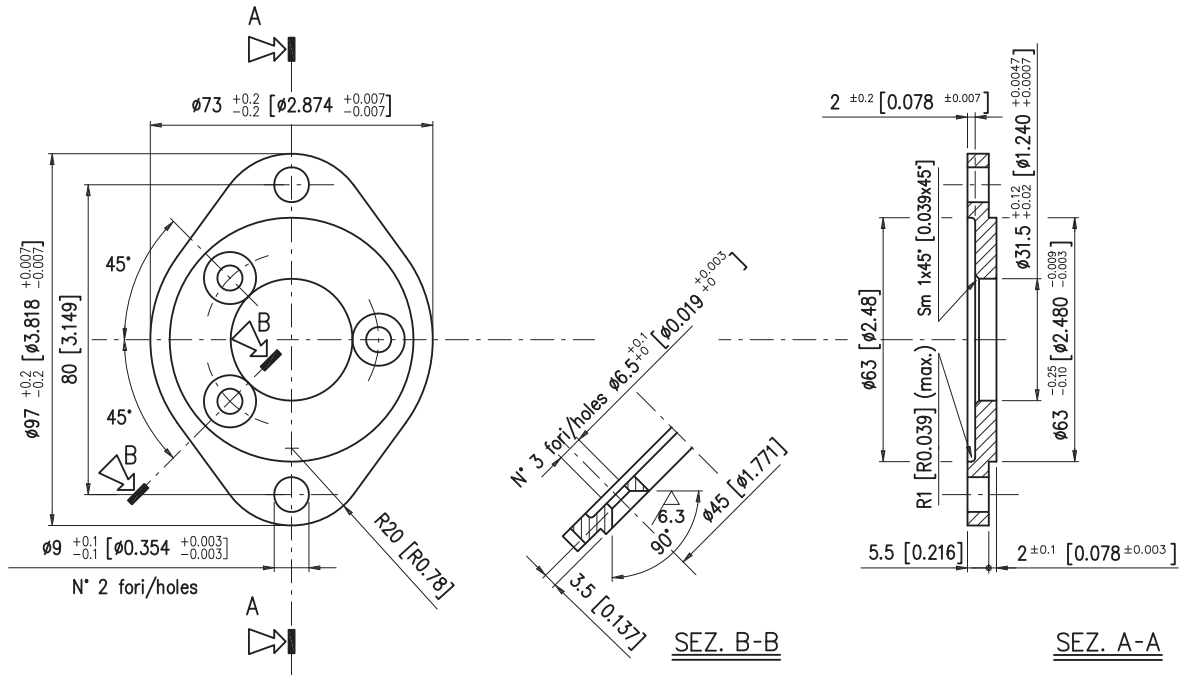

Montaggio flangia / Flange assembling

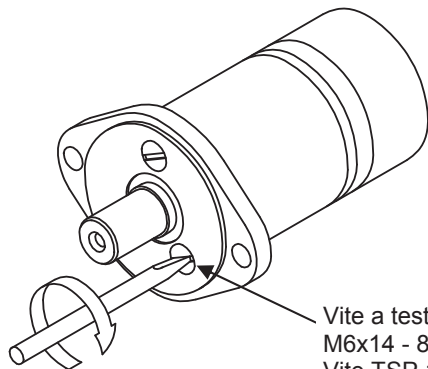

Vite a testa svasata piana con tagli M6x14 - 8.8 UNI 7688 (con flangia S).
M6x14 - 8.8 UNI 7688 flathead screw (with S flange).
Vite TSP 1/4-28 UNF 1/2" - 8.8 DIN 965 screw (con flangia T)
TSP 1/4-28 UNF 1/2" - 8.8 DIN 965 screw (with T flange)

ALBERO CILINDRICO CL160
CL160 CYLINDRICAL SHAFT

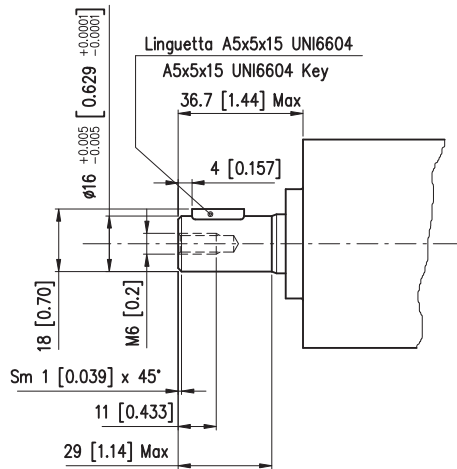

Coppia Massima 39Nm
Max Torque Continuous 39Nm [28.743 lbf·ft]

ALBERO SCANALATO SC160
SC160 SPLINED SHAFT

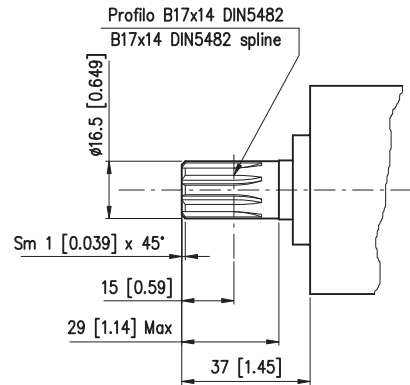

Coppia Massima 44Nm
Max Torque Continuous 44Nm [32.428 lbf·ft]

ALBERO CILINDRICO CL158
CL158 CYLINDRICAL SHAFT

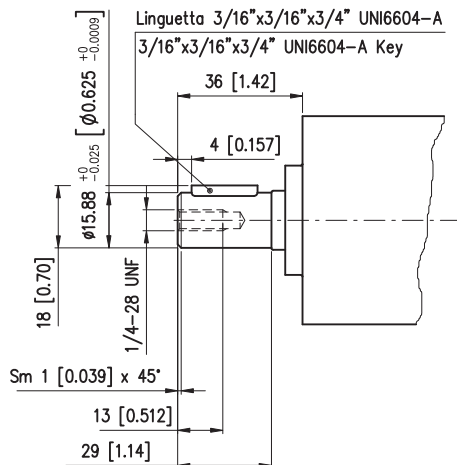

Coppia Massima 39Nm
Max Torque Continuous 39Nm [28.743 lbf·ft]

ALBERO CILINDRICO CROSSHOLE CS158
CS158 CYLINDRICAL CROSSHOLE SHAFT

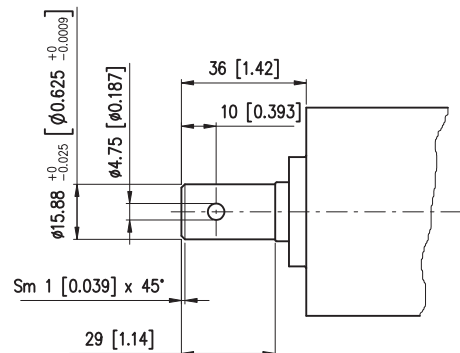

Coppia Massima 39Nm
Max Torque Continuous 39Nm [28.743 lbf·ft]

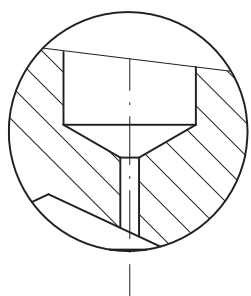
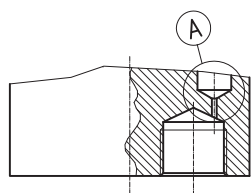

PART. A
Strozzatore fisso
Flow restrictor

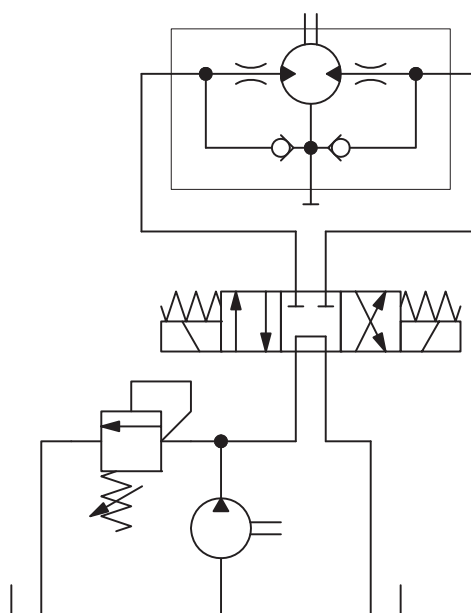

I motori BGM/FRQ dispongono di uno strozzatore sulla parte posteriore del motore che assicura velocità molto basse dell'albero anche in presenza di valori elevati di portata. Una tipica applicazione è quella della rotazione dei tubi di scarico delle turbine da neve montate su autocarri o trattori.

BGM/FRQ motors feature a restrictor at the back of the motor meant to ensure very low shaft speed though in presence of high flow. Typical applications are truck or tractor mounted snow blowers.

CURVE CARATTERISTICHE
PERFORMANCE CURVES

BGM...FRQ

Curva caratteristica della coppia (Nm) in funzione del numero di giri per le diverse pressioni di taratura della valvola a monte della strozzatura con foro $D = 1.2 \text{ mm}$ su motore BGM32.

Performance curves (torque/speed) according to pressure relief valve setting and 1.2 mm [0.047 in] diameter (for BGM32) of flow restrictor.

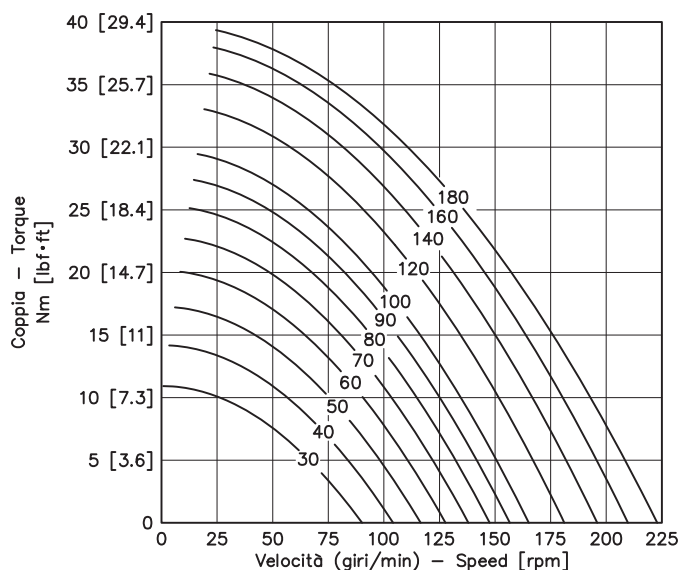

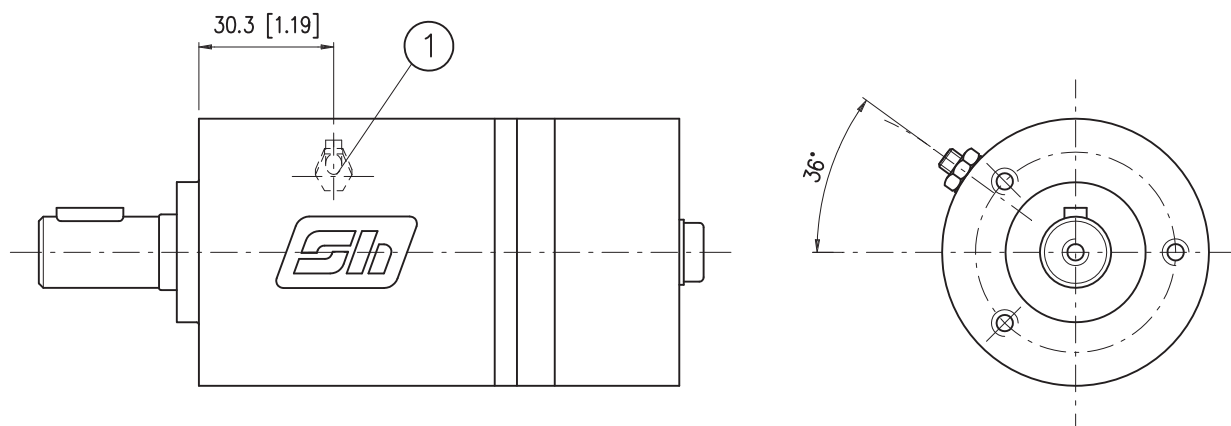

- 1) *Attacco sensore M5x0.5*
Sensor connection M5x0.5

**KIT SENSORE
SENSOR KIT**

1. *Cod. 424.0090.0000*
Sensore induttivo (1A) + dado di fissaggio
M5x0.5 (1B)
2. *Cod. 406.0730.0000*
Rondella di tenuta GM2000 M5

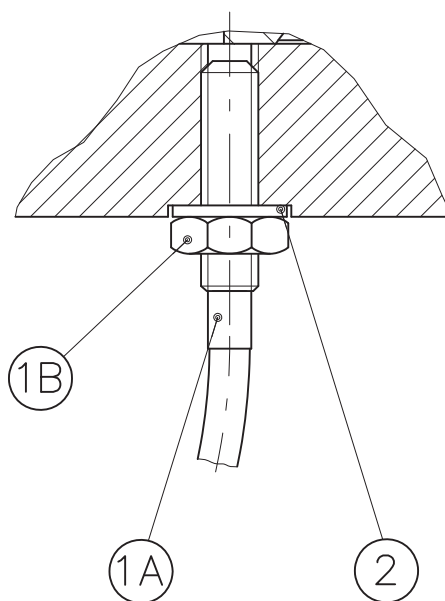

1. *Cod. 424.0090.0000*
inductive sensor (1A) + M5x0.5
locking nut (1B)
2. *Cod. 406.0730.0000*
Sealing washer GM2000 M5

Caratteristiche sensore elettronico

Numero d'impulsi per giro = 4
 Principio di funzionamento induttivo
 Funzione di uscita PNP
 Tensione nominale 10-30 V d.c.
 Caricabilità massima 200 mA
 Frequenza massima 3000 Hz
 Campo di temperatura -25° C +85° C
 Gradi di protezione IP 67
 Lunghezza cavo 2 m

**Segnale di uscita in versione elettronica
Output signal electronic tachometer**

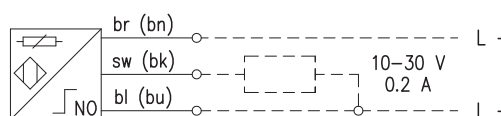
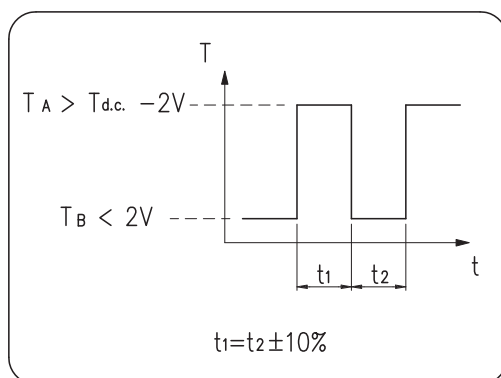

Electronic sensor technical features

Number of pulses for revolution = 4
 Inductive principle
 Output current PNP
 Voltage 10-30 V d.c.
 Max load 200 mA
 Max frequency 3000 Hz
 Temperature range -25°C +85°C
 Enclosure IP 67
 Cable length 2 m

**SENSO DI ROTAZIONE OTTIMALE
PREFERENTIAL DIRECTION OF ROTATION**

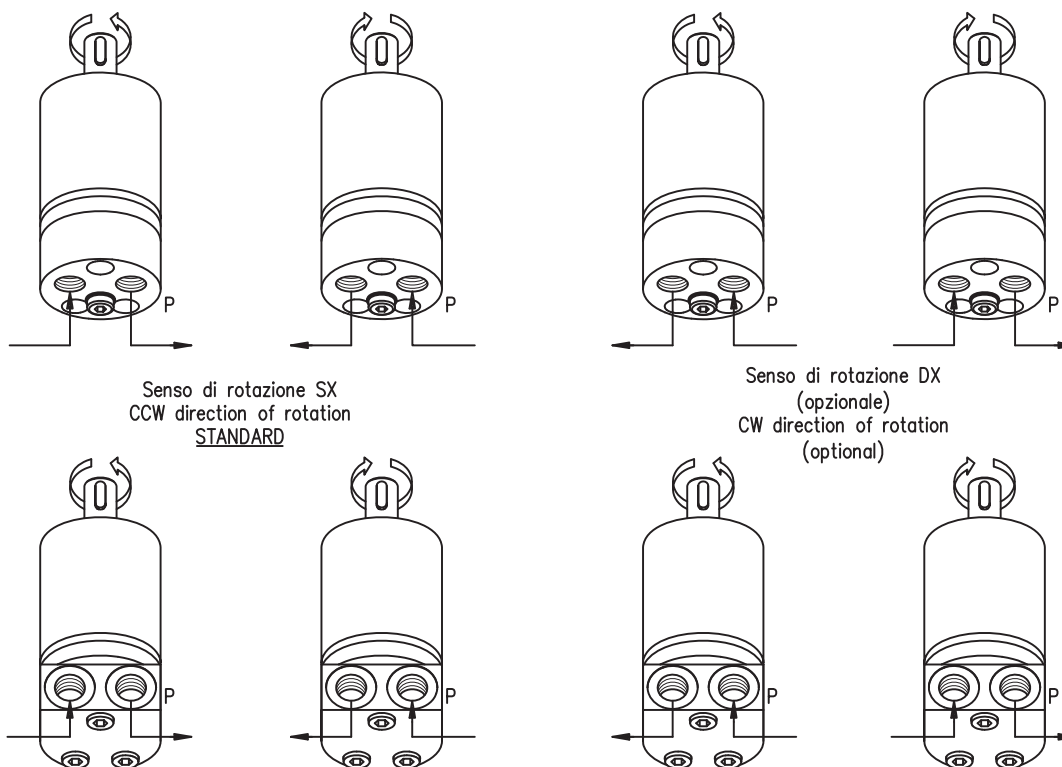

Si consiglia l'impiego della versione SX o DX in funzione del senso di rotazione prevalente del motore, al fine di sottoporre il sensore alla pressione tendenzialmente più bassa.

The selection of the version CW or CCW depends on the prevailing direction of rotation of the motor, in order to use the sensor at the lower working pressure.

CARICHI AMMESSI SULL'ALBERO SHAFT LOAD CAPACITY

Il carico radiale ammissibile dipende da

- Velocità (n)
- Distanza (L) del punto di carico dalla flangia

The permissible radial shaft load depends on

- Speed (n)
- Distance (L) from the point of load to the mounting flange

Formula utilizzabile per il calcolo del carico radiale (Pr) ai vari numeri di giri e alle varie distanze dalla flangia
Radial load capacity (Pr) curve according to speed (n) and distance (L) from flange

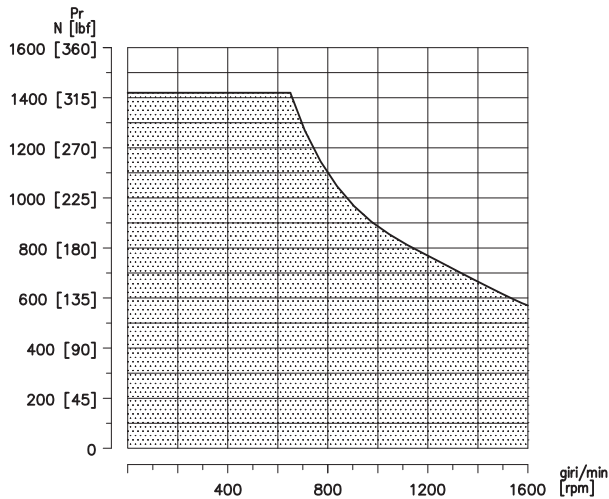

$$Pr = \frac{1500}{n} \cdot \frac{52300}{55.5 + L} \quad (N)$$

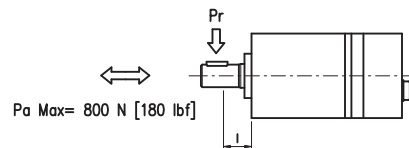

Formula valida per n >= 650 rpm
Per n < 650 rpm Prmax = 1450 N

This formula being valid for n >= 650 rpm
For n < 650 rpm Prmax = 1450 N [326.25 lbf]

La curva mostra la relazione tra (Pr) e (n)

The curve shows the relation between (Pr) and (n)

- L = 20 mm [0.78 in]

COPPIE DI SERRAGGIO TIGHTENING TORQUE

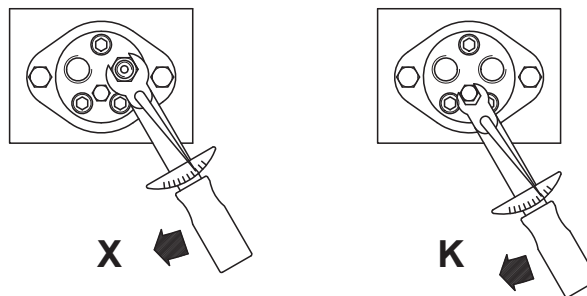

	X	K
Raccordi - Nipples	3/8 G (BSPP)	1/8 G (BSPP)
con rondella in acciaio - with steel washer	60 Nm 44.2 [lbf·ft]	20 Nm 14.7 [lbf·ft]
con rondella in alluminio - with aluminium washer	40 Nm 29.4 [lbf·ft]	10 Nm 7.3 [lbf·ft]
con rondella in rame - with copper washer	60 Nm 44.2 [lbf·ft]	20 Nm 14.7 [lbf·ft]

BGM 013

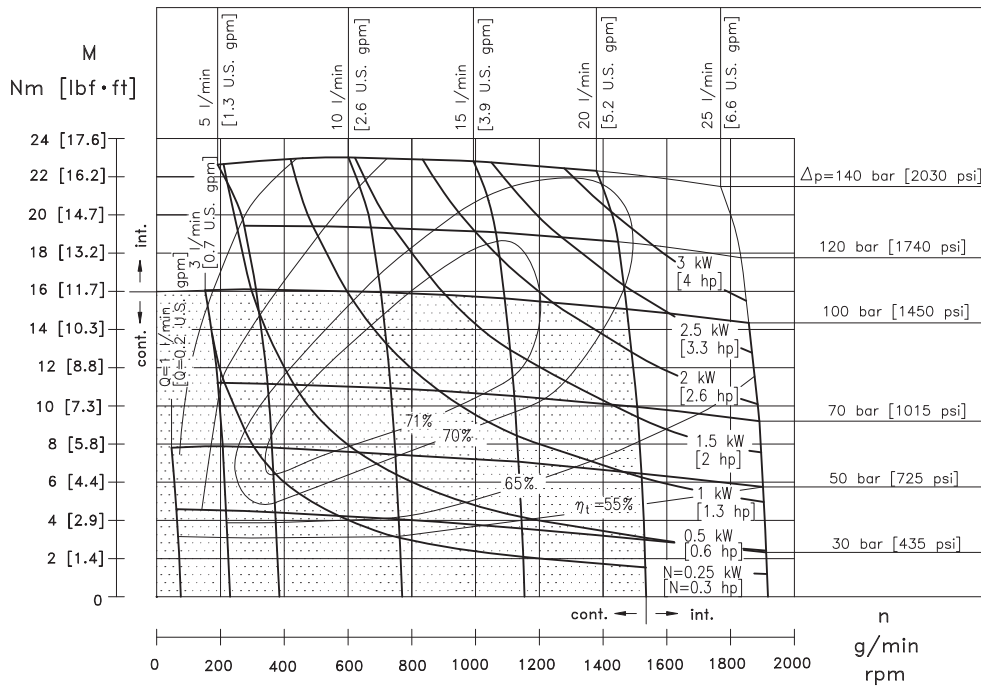

Pressioni e portate superiori a quelle ammesse in regime continuo non devono essere applicate contemporaneamente.
Exceeding continuous pressure values or exceeding flow values indicated, must not occur simultaneously.

BGM 020

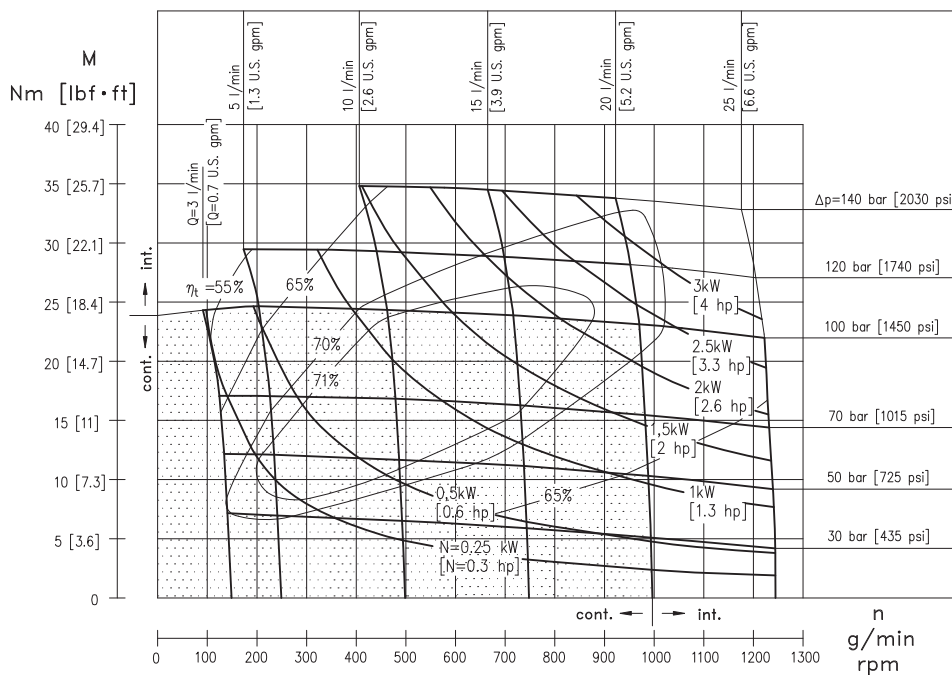

Pressioni e portate superiori a quelle ammesse in regime continuo non devono essere applicate contemporaneamente.
Exceeding continuous pressure values or exceeding flow values indicated, must not occur simultaneously.

BGM 032

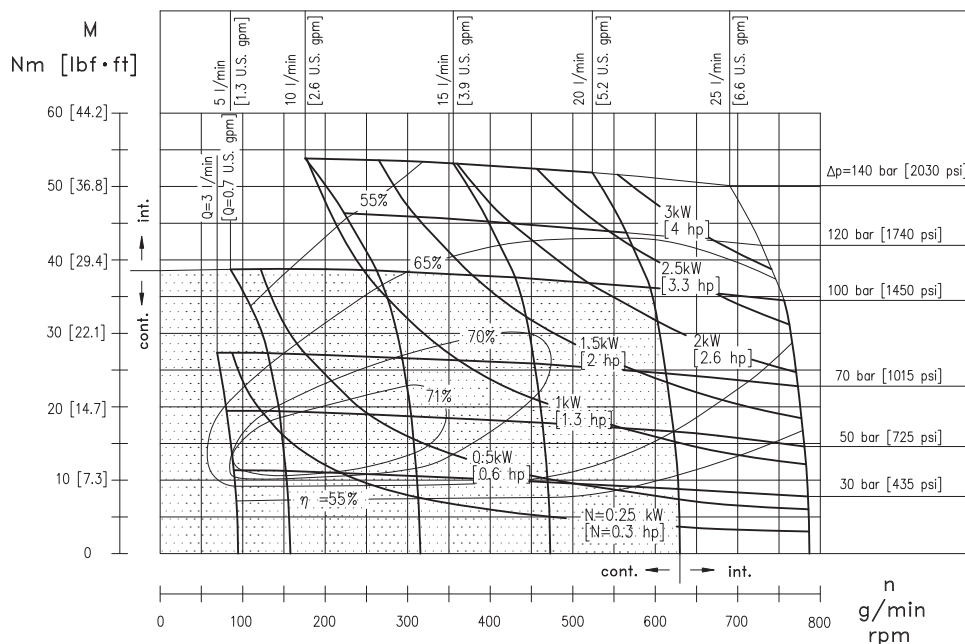

Pressioni e portate superiori a quelle ammesse in regime continuo non devono essere applicate contemporaneamente. Exceeding continuous pressure values or exceeding flow values indicated, must not occur simultaneously.

BGM 040

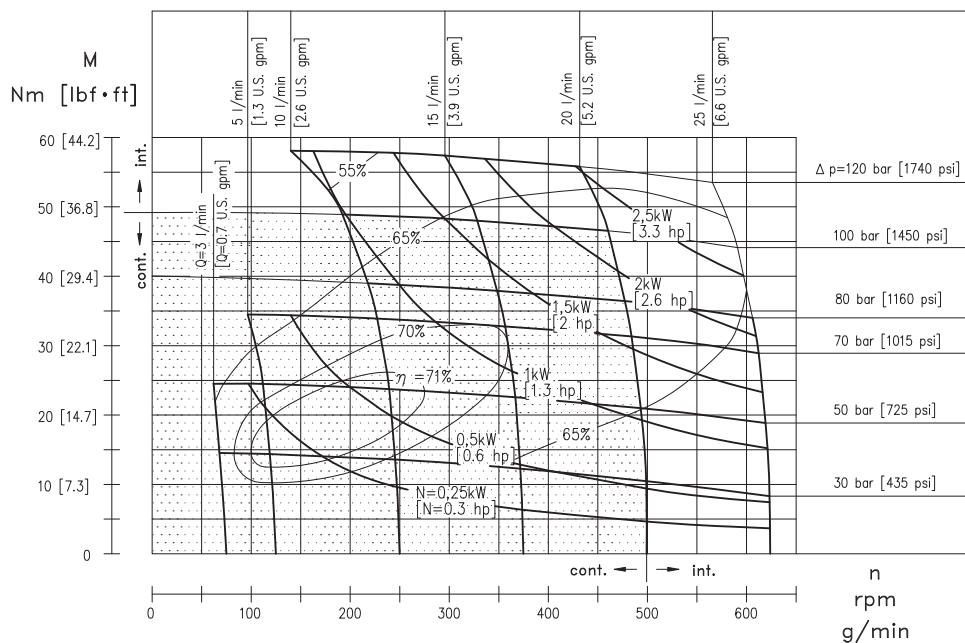

Pressioni e portate superiori a quelle ammesse in regime continuo non devono essere applicate contemporaneamente. Exceeding continuous pressure values or exceeding flow values indicated, must not occur simultaneously.

BGM 050

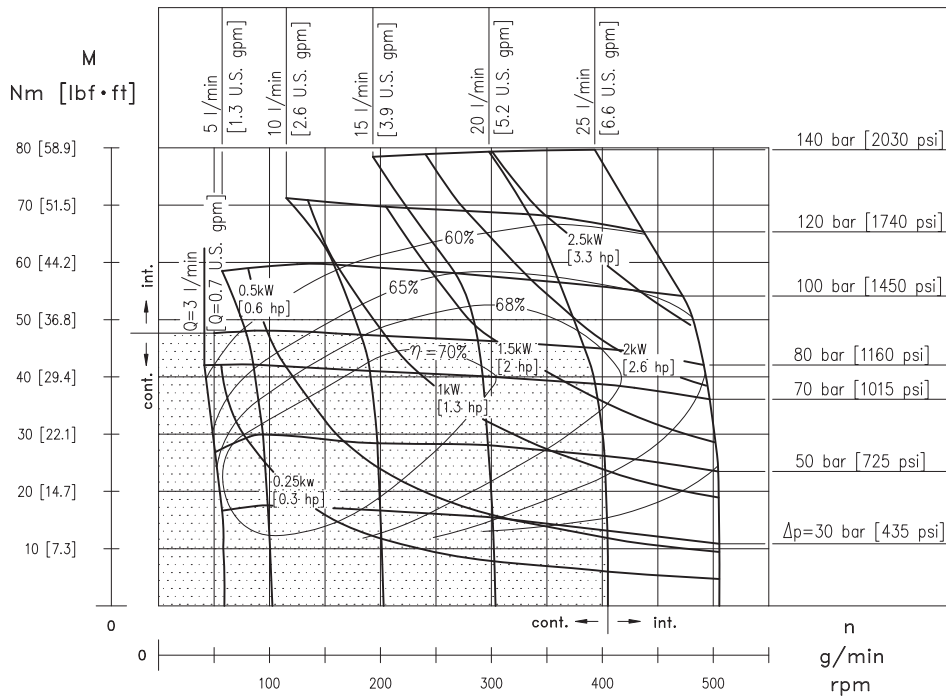

Pressioni e portate superiori a quelle ammesse in regime continuo non devono essere applicate contemporaneamente.
Exceeding continuous pressure values or exceeding flow values indicated, must not occur simultaneously.