

# Water Strainer

## Removal of foreign matter in water line

### Specifications

Model	Port size	Fluid *1	Proof pressure	Max. operating pressure	Mesh	Ambient and fluid temperature	Weight
WF300-□	Rc1/4, 3/8, 1/2	Water	1.67 MPa	1.18 MPa	100 mesh	5 to 80°C	0.29 kg
WF300-□-1-X204					70 mesh		
WF300-□-2-X204					50 mesh		
WF300-□-3-X204					25 mesh		

\*1: Cannot be used with deionized water.

### How to Order

WF300-**02**-□

Port size		Mesh	
02	Rc1/4	Nil	100 mesh
03	Rc3/8	1-X204	70 mesh
04	Rc1/2	2-X204	50 mesh
		3-X204	25 mesh

Mesh:  
100/70/50/25 mesh



### Related Equipment

#### Water Regulator WR110-□-X224/WR110-□-X215

Body material:  
Special brass



Port size  
 · Set pressure range (-X224):  
 0.08 to 0.39 MPa  
 Rc1/8, Rc1/4  
 · Set pressure range (-X215):  
 0.05 to 0.69 MPa  
 Rc1/8, Rc1/4  
 NPT1/8, NPT1/4



#### Check Valve INA-14-290/XTO-674-□□

Body material: Brass

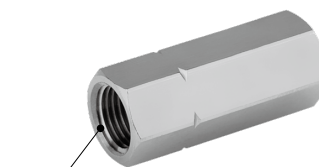

Port size: Rc1/8



Port size: Rc1/4, 3/8, 1/2

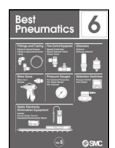

Best Pneumatics

# Series WF300

## Dimensions

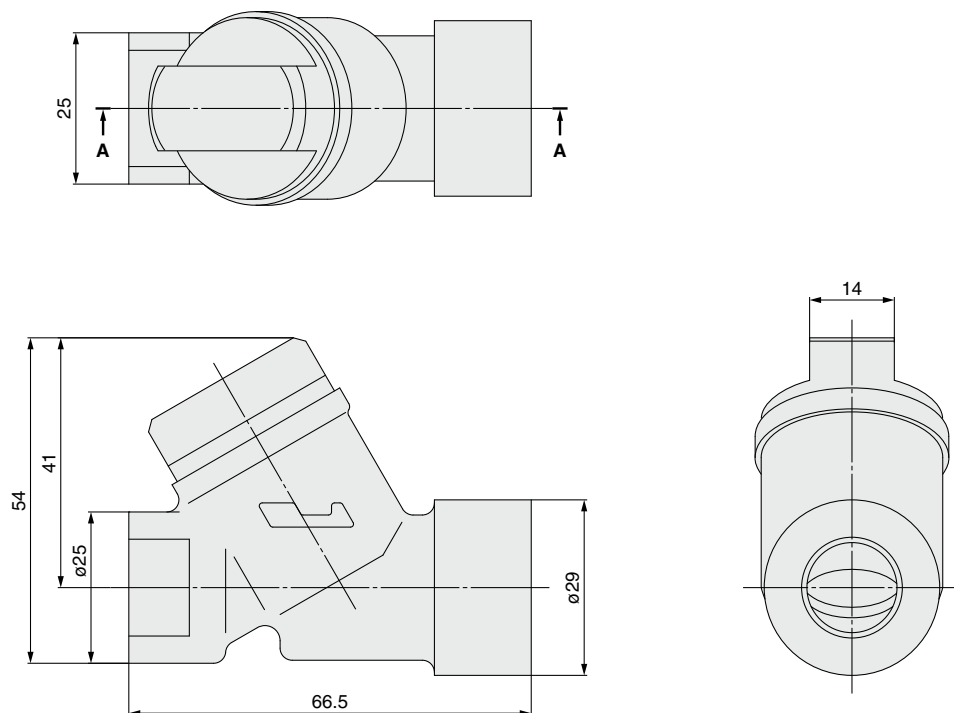

## Construction

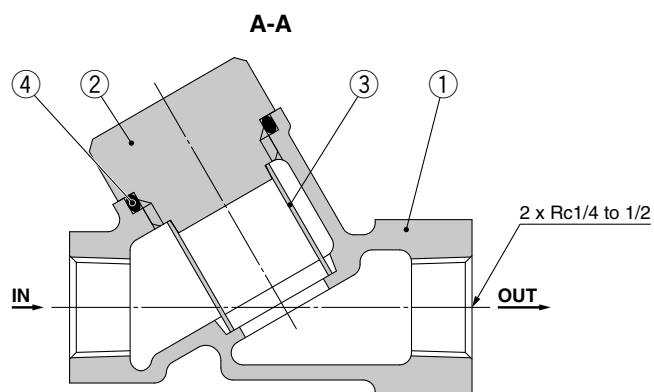

### Component Parts

No.	Description	Material
1	Body	Bronze casted
2	Cap	Brass
4	O-ring	NBR

\*: Please contact SMC for O-rings which are made of fluorine-based materials.

### Replacement Parts

No.	Description	Material	Part number			
			100 mesh	70 mesh	50 mesh	25 mesh
3	Element	Stainless steel	11366	11366-1-1	11366-2-1	11366-3-1

**⚠ Safety Instructions** Be sure to read the "Handling Precautions for SMC Products" (M-E03-3) and "Operation Manual" before use.