

Aluminum High Vacuum Angle Valve

XL□ Series

The production of flange sizes 16, 25, 40, 50, 63, and 80 for the XLA(V)/XLC(V)/XLF(V)/XLG(V) series has been discontinued. Please select the new XL□-2 type. See [here](#) for details.

RoHS

- High fluorine resistance
- Minimal outgassing
- Minimal contamination from heavy metals

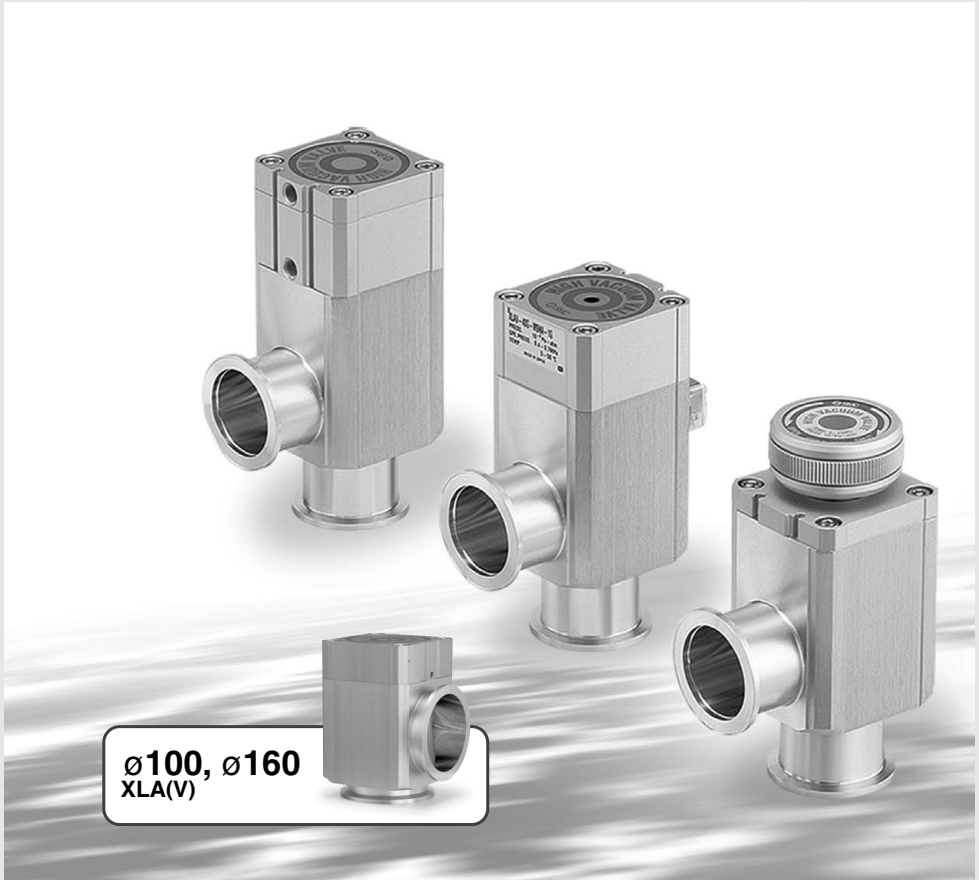

Ø100, Ø160
XLA(V)

XLA

XL□

XL□Q

XM□

XY□

D-□

XSA

XVD

XGT

CYV

Aluminum High Vacuum Angle Valve **XL Series**

Lightweight, Compact

Large conductance, small body
Excellent resistance against fluorine corrosion (body)

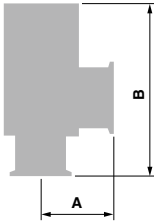

XL* Series Case

Model	A* (mm)	B (mm)	Weight (kg)	Conductance* (L/s)
XLA-16	40	103	0.25	5
XLA-25	50	113	0.45	14
XLA-40	65	158	1.1	45
XLA-50	70	170	1.6	80
XLA-63	88	196	2.9	160
XLA-80	90	235	5.0	200
XLA-100	108	300	10.6	300
XLA-160	138	315	18.5	800

* Common to all series.

Low outgassing

Low outgassing makes it possible to use a lower capacity pump and also to shorten evaluation time.

Little heavy metal contamination

The valve does not contain heavy metals such as Ni (nickel) or Cr (chrome) and a low sputtering yield also helps to minimize heavy metal contamination of semiconductor wafers.

Uniform baking temperature

Excellent thermal conductivity results in a uniform temperature for the entire valve body and a marked decrease in the condensation of gases inside the valve.

Comparison with KF25 flange

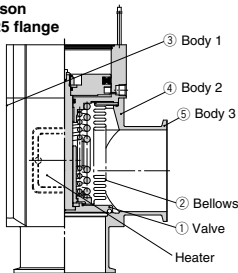

Temperature distribution of 120°C specifications

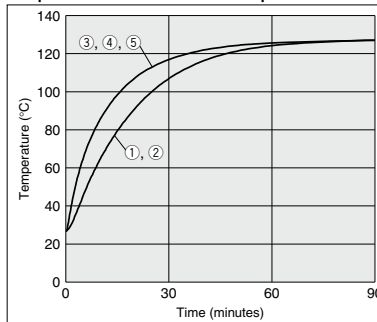

High Vacuum Angle Valves XL Series Features

XLA/XLAV (Bellows seal, Single acting)

- Particulate-free and clean room compatible bellows type
- Pressure-balance mechanism

XLG/XLGV (Bellows seal, Double acting)

- Particulate-free and clean room compatible bellows type
- Pressure-balance mechanism

XLV/XLTV (O-ring seal, Single acting)

- High speed response
- Particulates are reduced through special surface treatment of shaft seal.

XLG/XLGV (O-ring seal, Double acting)

- High speed response
- Particulates are reduced through special surface treatment of shaft seal.

XLD/XLDV (2-Step control, Single acting)

- Initial stage exhaust valve and main exhaust valve are combined. (flow rate 2-step control valve)
- Designed with a compact system and reduced piping
- Prevents particulate turbulence inside the chamber during exhaustion.
- Prevents pumps from running while overloaded.
- Initial exhaust valve flow is adjustable.

XLH (Bellows type, Manual)

- Bellows type is particulate free and cleaned.
- Pressure balance mechanism allows unrestricted exhaust direction.
- Low actuation torque (0.5 N·m or less)
- Spring provides standard sealing load.
- Handle height is the same when valve is open or closed.
- Indicator to confirm opening and closing of valve is standard equipment.













XLS (Bellows pressure balance, Normally closed electromagnetic)

- Particulates are reduced because there are no sliding metal parts.
- Pressure balance mechanism allows unrestricted exhaust direction.
- A control power supply circuit for solenoid valve drive has been made standard.
- Can be used in portable equipment since air for drive is not necessary.

Series Variations

The production of flange sizes 16, 25, 40, 50, 63, and 80 for the XLA(V)/XLC(V)/XLF(V)/XLG(V) series has been discontinued. Please select the new XL□-2 type. See [here](#) for details.

High Vacuum Angle Valves

Actuation	Application	Shaft seal system	Model	Valve type	Operating pressure (Pa) (abs)	Leakage (Pa·m ³ /s)		Flange size						Option				Page												
						(Note)	(Note)	16	25	40	50	63	80	100	160	Switch	Heater		Indicator	High temperature spcs.										
Air operated	Particle free cleaned	Bellows seal		Single acting (N.C.)	10 ⁻⁶ to atmospheric pressure	10 ⁻¹⁰	10 ⁻¹¹	●	●	●	●	●	●	●	●	●	●	●	●	●	●	P.416 to P.419								
			(Size 16: None)																											
				Double acting				●	●	●	●	●	●	●	●	●	●	●	●	●	●	●	●	●	●	P.420 to P.424				
			(Size 16: None)																											
		Double acting	●	●	●	●	●	●	●	●	●	●	●	●	●	●	●	●	●	●	P.426 to P.435									
	(Size 16: None)																													
		Double acting	●	●	●	●	●	●	●	●	●	●	●	●	●	●	●	●	●	●	P.436 to P.447									
	(Size 16: None)																													
	High speed operation High volume operation	O-ring seal		Single acting (N.C.)	10 ⁻⁵ to atmospheric pressure	10 ⁻¹⁰	10 ⁻¹⁰	Production discontinued												●	●	●	●	●	●	●	●	●	●	P.448 to P.453
			(Size 16: None)																											
			Double acting	●				●	●	●	●	●	●	●	●	●	●	●	●	●	●	●	●	●	●	P.454 P.455				
(Size 16: None)																														
	Double acting	●	●	●	●	●	●	●	●	●	●	●	●	●	●	●	●	●	●	●	P.456 to P.458									
(Size 16: None)																														
	Double acting	●	●	●	●	●	●	●	●	●	●	●	●	●	●	●	●	●	●	●	P.459 to P.464									
(Size 16: None)																														
Prevents turbulence of particulates. Prevents a pump from running overloaded.	Bellows seal O-ring seal		Single acting (N.C.)	10 ⁻⁶ to atmospheric pressure	10 ⁻¹⁰	10 ⁻¹¹	●	●	●	●	●	●	●	●	●	●	●	●	●	●	●	P.465 to P.470								
		Standard																												
	Double acting	●	●	●	●	●	●	●	●	●	●	●	●	●	●	●	●	●	●	●	P.471 to P.476									
Standard																														
Manual	Particle free cleaned	Bellows seal		Manual	10 ⁻⁶ to atmospheric pressure	10 ⁻¹⁰	10 ⁻¹¹	●	●	●	●	●	●	●	●	●	●	●	●	●	●	P.477 to P.482								
			Standard-Standard (Size 16: None)																											
Electromagnetic	For portable equipment not requiring air	(Bellows balance)		Single acting (N.C.)	10 ⁻⁸ to 0.1 MPa (G)	10 ⁻⁸	10 ⁻¹¹	●	●	●	●	●	●	●	●	●	●	●	●	●	P.483 to P.488									
			Standard																											

(Note) In case of standard seal material (FKM)

* Heater and high temperature specifications are not available with switches.

- XLA
- XL□
- XL□Q
- XM□
- XY□
- D-□
- XSA
- XVD
- XGT
- CVV

Aluminum High Vacuum Angle Valve Normally Closed/Bellows Seal

XLA/XLAV Series

RoHS



XLA

How to Order

The production of flange sizes 16, 25, 40, 50, 63, and 80 for the XLA(V) series has been discontinued. Please select the new XLA(V)-2 type. See [here](#) for details.

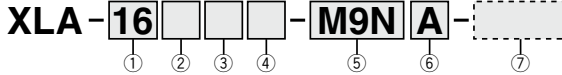

① Flange size

Size
16
25
40
50
63
80
100
160

② Flange type

Symbol	Type	Applicable flange
NII	KF (NW)	16, 25, 40, 50, 63, 80 100, 160
D	K (DN)	63, 80, 100, 160

③ Indicator/Pilot port direction

Symbol	Indicator	Pilot port direction
Nil	Without indicator	Flange side
A	With indicator	Flange side
F		Left flange surface
G		Rear flange surface
J	Without indicator	Right flange surface
K		Left flange surface
L		Rear flange surface
M		Right flange surface

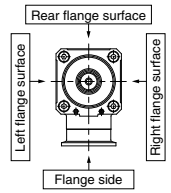

④ Temperature specifications/Heater

Symbol	Temperature	Heater
Nil	5 to 60°C	—
High temperature type	H0	—
	H4	With 100°C heater
	H5	With 120°C heater

Note) Size 16 is not applicable for H4, H5, Size 25 not for H4.

⑥ Number of auto switches/Mounting position

Symbol	Quantity	Mounting position
Nil	Without auto switch	—
A	2 pcs.	Valve open/closed
B	1 pc.	Valve open
C	1 pc.	Valve closed

⑤ Auto switch type

Symbol	Auto switch model	Remarks
Nil	—	Without auto switch (without built-in magnet)
M9N(M)(L)(Z)	D-M9N(M)(L)(Z)	Solid state auto switch
M9P(M)(L)(Z)	D-M9P(M)(L)(Z)	
M9B(M)(L)(Z)	D-M9B(M)(L)(Z)	
A90(L)	D-A90(L)	Reed auto switch (Not applicable to flange size 16)
A93(M)(L)(Z)	D-A93(M)(L)(Z)	Without auto switch (with built-in magnet)
M9I/	—	

Note 1) Auto switches shown above cannot be mounted on the high temperature type. For the high temperature type, a semi-standard product that uses the heat resistant auto switch D-F7NJ* is available. For details, please contact SMC.

Note 2) Standard lead wire length is 0.5 m. Add "L" to the end of the part number when 3 m is desired, "M" when 1 m, and "Z" when 5 m.

Example) -M9NL

⑦ Body surface treatment/Seal material and its changed part

• Body surface treatment

Symbol	Surface treatment
Nil	External: Hard anodized Internal: Raw material
A	External: Hard anodized Internal: Oxalic acid anodized

• Seal material

Symbol	Seal material	Compound No.
Nil	FKM	1349-80*
N1	EPDM	2101-80*
P1	Barrel Perfluoro®	70W
Q1	Chemraz®	4079
R1		SS592
R2		SS630
R3		SSE38
S1		VMQ
T1	FKM for Plasma	3310-75*
U1	ULTIC ARMOR®	UA4640

* Produced by Mitsubishi Cable Industries, Ltd.

• Seal material changed part and leakage

Symbol	Changed part	Leakage (Pa·m ³ /s or less) Note 1)	
		Internal	External
Nil	None	1.3 x 10 ⁻¹⁰ (FKM)	1.3 x 10 ⁻¹¹ (FKM)
A	②, ③	1.3 x 10 ⁻⁸	1.3 x 10 ⁻⁹
B	②	1.3 x 10 ⁻⁸	1.3 x 10 ⁻¹¹ (FKM)
C	③	1.3 x 10 ⁻¹⁰ (FKM)	1.3 x 10 ⁻⁹

Note 1) Values at normal temperature, excluding gas permeation.

Note 2) Refer to parts number of "Construction" on page 418 for changed part. Number indicates parts number of "Construction" accordingly.

To order something other than "Nil" (standard), list the symbols starting with "X," followed by each symbol for "body surface treatment," "seal material" and then "changed part".

Example) XLA-16-M9NA-XAN1A

Barrel Perfluoro® is a registered trademark of Matsumura Oil Co., Ltd.
 Kalrez® is a registered trademark of E. I. du Pont de Nemours and Company or its affiliates.
 Chemraz® is a registered trademark of Greene, Tweed Technologies, Inc.
 ULTIC ARMOR® is a registered trademark of Nippon Valqua Industries, Ltd.

Air Operated/with Solenoid Valve

The production of flange sizes 16, 25, 40, 50, 63, and 80 for the XLA(V) series has been discontinued. Please select the new XLA(V)-2 type. See [here](#) for details.



How to Order



XLAV

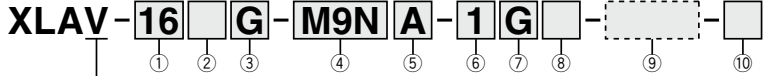

• Air operated/with solenoid valve

① Flange size

Size
16
25
40
50
63
80
100
160

② Flange type

Symbol	Type	Applicable flange
NII	KF (NW)	16, 25, 40, 50, 63, 80 100, 160
D	K (DN)	63, 80, 100, 160

③ Indicator/Pilot port direction

Symbol	Indicator	Pilot port direction
F	With indicator	Left flange surface
		Rear flange surface
		Right flange surface
J	Without indicator	Left flange surface
		Rear flange surface
		Right flange surface
M		Right flange surface

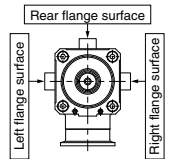

* M type plug connector (AC power supply) not attached for J, M of sizes 16 and 25.

④ Auto switch type

Symbol	Auto switch model	Remarks
NII	—	Without auto switch (without built-in magnet)
M9N(M)(L)(Z)	D-M9N(M)(L)(Z)	Solid state auto switch
M9P(M)(L)(Z)	D-M9P(M)(L)(Z)	
M9B(M)(L)(Z)	D-M9B(M)(L)(Z)	
A90(L)	D-A90(L)	Reed auto switch (Not applicable to flange size 16)
A93(M)(L)(Z)	D-A93(M)(L)(Z)	
M9//	—	Without auto switch (with built-in magnet)

Standard lead wire length is 0.5 m. Add "L" to the end of the part number when 3 m is desired, "M" when 1 m, and "Z" when 5 m.

Example) M9NL

⑤ Number of auto switches/Mounting position

Symbol	Quantity	Mounting position
NII	Without auto switch	—
A	2 pcs.	Valve open/closed
B	1 pc.	Valve open
C	1 pc.	Valve closed

⑥ Rated voltage

		CE-compliant
1	100 VAC, 50/60 Hz	—
2	200 VAC, 50/60 Hz	—
3	110 VAC, 50/60 Hz	—
4	220 VAC, 50/60 Hz	—
5	24 VDC	○
6	12 VDC	○

⑦ Electrical entry

G	Grommet (Lead wire length 300 mm)
H	Grommet (Lead wire length 600 mm)
L	L type plug connector
M	M type plug connector

⑧ Light/Surge voltage suppressor

NII	None
S	With surge voltage suppressor
Z	With light/surge voltage suppressor
U	With light/surge voltage suppressor (Non-polar type)

* S type: Not available for AC.
* U type: DC only.

⑩ CE-compliant

NII	—
Q	CE-compliant

⑨ Body surface treatment/Seal material and its changed part

• Body surface treatment

Symbol	Surface treatment
NII	External: Hard anodized Internal: Raw material
A	External: Hard anodized Internal: Oxalic acid anodized

• Seal material

Symbol	Seal material	Compound No.
NII	FKM	1349-80 [®]
N1	EPDM	2101-80 [®]
P1	Barrel Perfluoro [®]	70W
Q1	Kalrez [®]	4079
R1	Chemraz [®]	SS592
R2		SS630
R3		SSE38
S1		VMQ
T1	FKM for Plasma	3310-75 [®]
U1	ULTIC ARMOR [®]	UA4640

* Produced by Mitsubishi Cable Industries, Ltd.

Barrel Perfluoro[®] is a registered trademark of Matsumura Oil Co., Ltd.
Kalrez[®] is a registered trademark of E. I. du Pont de Nemours and Company or its affiliates.
Chemraz[®] is a registered trademark of Greene, Tweed Technologies, Inc.
ULTIC ARMOR[®] is a registered trademark of Nippon Valqua Industries, Ltd.

• Seal material changed part and leakage

Symbol	Changed part ^{Note 2)}	Leakage (Pa·m ³ /s or less) ^{Note 1)}	
		Internal	External
NII	None	1.3 x 10 ⁻¹⁰ (FKM)	1.3 x 10 ⁻¹¹ (FKM)
A	②, ③	1.3 x 10 ⁻⁸	1.3 x 10 ⁻⁹
B	②	1.3 x 10 ⁻⁸	1.3 x 10 ⁻¹¹ (FKM)
C	③	1.3 x 10 ⁻¹⁰ (FKM)	1.3 x 10 ⁻⁹

Note 1) Values at normal temperature, excluding gas permeation.

Note 2) Refer to parts number of "Construction" on page 418 for changed part. Number indicates parts number of "Construction" accordingly.

To order something other than "NII" (standard), list the symbols starting with "X," followed by each symbol for "body surface treatment," "seal material" and then "changed part".

Example) XLAV-16-M9NA-1G-XAN1A

Note 1) Option specifications/Combinations

This model has indicator, auto switch and K(DN) flange options, but high temperature/heater options are not available.

Note 2) Solenoid valves

XLAV-16, 25, 40, 50: SYJ319, XLAV-63, 80, 100, 160: SYJ519

Example) SYJ319-1GS, etc.

* For details, consult your SMC sales representative.

* For option "Q", the solenoid valve should be a CE-compliant product.

XLA/XLAV Series

Specifications

Model	XLA(V)-16	XLA(V)-25	XLA(V)-40	XLA(V)-50	XLA(V)-63	XLA(V)-80	XLA(V)-100	XLA(V)-160	
Valve type	Normally closed (Pressurize to open, Spring seal)								
Fluid	Inert gas under vacuum								
Operating temperature (°C)	XLA	5 to 60 (High temperature type: 5 to 150)							
	XLAV	5 to 50							
Operating pressure (Pa) (abs)	1 x 10 ⁻⁶ to atmospheric pressure								
Conductance (L/s) ^{Note 1)}	5	14	45	80	160	200	300	800	
Leakage (Pa·m ³ /s)	Internal	In case of standard material FKM: 1.3 x 10 ⁻¹⁰ at normal temperature, excluding gas permeation							
	External	In case of standard material FKM: 1.3 x 10 ⁻¹¹ at normal temperature, excluding gas permeation							
Flange type	KF (NW)				KF (NW), K (DN)				
Principal materials	Body: Aluminum alloy, Bellows: Stainless steel 316L, Main part: Stainless steel, FKM (Standard seal material)								
Surface treatment	External: Hard anodized Internal: Raw material								
Pilot pressure (MPa) (G)	0.4 to 0.7								
Pilot port size	XLA	M5			Rc1/8				Rc1/4
	XLAV	M5: Port 1(P), Port 3(R)				Rc1/8: Port 1(P), M5: Port 3(R)			
Weight (kg)	XLA	0.25	0.45	1.1	1.6	2.9	5.0	10.6	18.5
	XLAV	0.29	0.49	1.14	1.64	2.96	5.06	10.7	18.6

Note 1) Conductance is the value for an elbow with the same dimensions.

Note 2) For valve heater specifications, refer to "Common Option [1] Heater" on page 459.

Construction/Operation

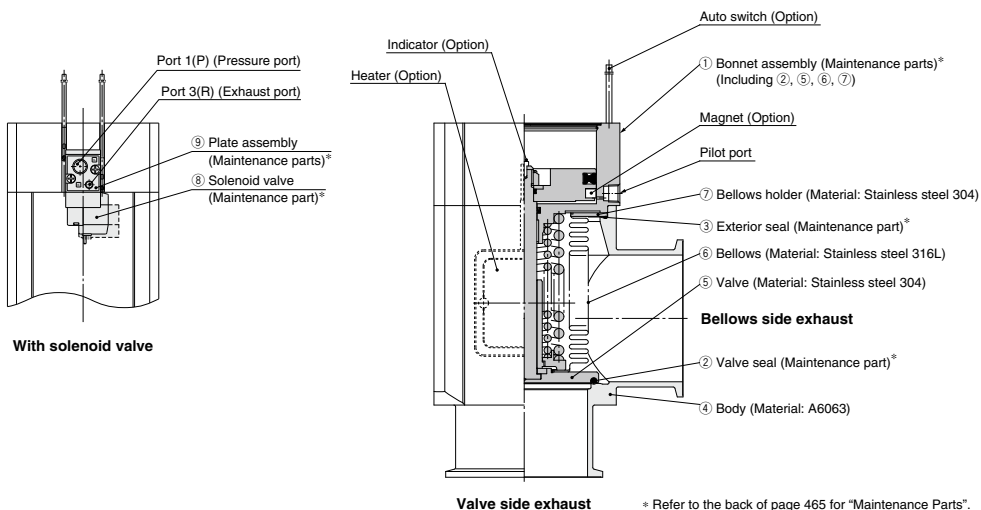

<Working principle>

By applying the pilot pressure from the pilot port, the piston-coupled valve overcomes the spring force or operating force by pressure, and the valve opens.

For the XLAV, the pilot pressure is always applied to the port 1(P), and the valve opens when the solenoid valve is turned ON and closes when it is turned OFF.

<Options>

Auto switch: The magnet activates the auto switch. With 2 auto switches, the open and closed positions are detected, and with 1 auto switch, either the open or closed position is detected. Auto switches are applicable at ordinary temperatures only (5 to 60°C).

Heater: Simple heating is performed using thermistors. The valve body can be heated to approximately 100 or 120°C, depending on the heater option and the valve size. The type and number of thermistors to be used will vary depending upon size and setting temperature. In the case of high temperature specifications, the bonnet assembly is a heat resistant structure. This does not apply in cases where a solenoid valve is attached.

Indicator: When the valve is open, an orange marker appears in the center of the name plate.

Dimensions

XLA/Air operated

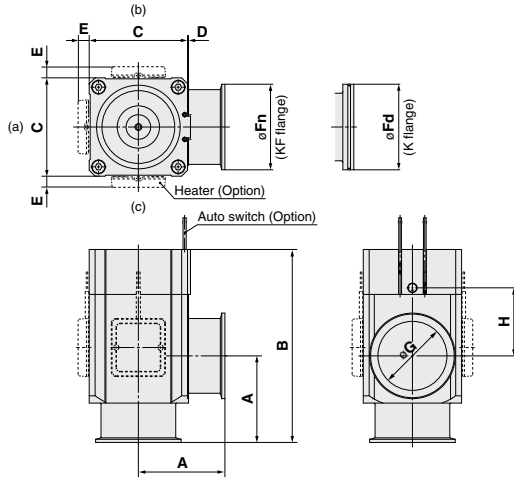

Model	A	B	C	D	E (Note 1)	Fn	Fd	G	H
XLA-16	40	103	38	1	—	30	—	17	40
XLA-25	50	113	48	1	12	40	—	26	39
XLA-40	65	158	66	2	11	55	—	41	63
XLA-50	70	170	79	2	11	75	—	52	68
XLA-63	88	196	100	3	11	87	95	70	69
XLA-80	90	235	117	3	11	114	110	83	96
XLA-100	108	300	154	3	11	134	130	102	131
XLA-160	138	315	200	3	11	190	180	153	112

Note 1) Dimension E applies when heater option is included. (Lead wire length: approx. 1 m)
 Note 2) (a), (b) and (c) in the above drawing indicate heater mounting positions.

Moreover, heater mounting positions will differ depending on the type of heater.

For further details, refer to mounting positions under "Replacement Heaters" on page 465.

XLAV/With solenoid valve

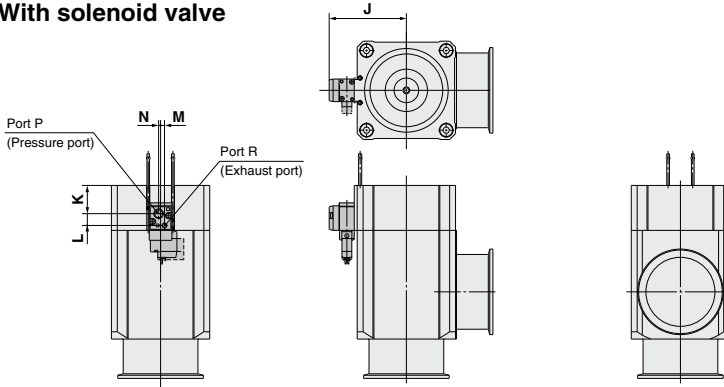

Model	J	K	L	M	N
XLAV-16	35.5	12.3	10.2	3.6	3.6
XLAV-25	40.5	13.8	10.2	3.6	3.6
XLAV-40	50.5	21.6	10.2	3.6	3.6
XLAV-50	57	24.6	10.2	3.6	3.6

Model	J	K	L	M	N
XLAV-63	78.5	28.7	12	4	2
XLAV-80	87	38.7	12	4	2
XLAV-100	105.5	50.7	12	4	2
XLAV-160	128.5	57.7	12	4	2

* Other dimensions are the same as the XLA.

* For details, consult your SMC sales representative.

* Other dimensions are the same as the XLA.

* For details, consult your SMC sales representative.

- XLA**
- XL□**
- XL□Q**
- XM□**
- XY□**
- D-□**
- XSA**
- XVD**
- XGT**
- CYV**

Aluminum High Vacuum Angle Valve Double Acting/Bellows Seal

The production of flange sizes 16, 25, 40, 50, 63, and 80 for the XLC(V) series has been discontinued. Please select the new XLC(V)-2 type. See [here](#) for details.

RoHS

XLC/XLCV Series

How to Order

Flange size
16, 25, 40

XLC - 16 [] [] [] - M9N A - []

Flange size
50, 63, 80, 100, 160

XLC - 50 [] [] [] - 1 M9N A - []



XLC16 to 40

① Flange size

Size
16
25
40
50
63
80
100
160

② Flange type

Symbol	Type	Applicable flange
Nil	KF (NW)	16, 25, 40, 50, 63, 80 100, 160
D	K (DN)	63, 80, 100, 160

③ Pilot port direction

Symbol	Pilot port direction
Nil	Flange side
K	Left flange surface
L	Rear flange surface
M	Right flange surface

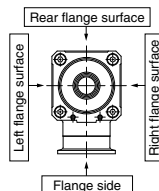

④ Temperature specifications/Heater

Symbol	Temperature	Heater
Nil	5 to 60°C	—
High temperature type	H0	—
	H4	5 to 150°C With 100°C heater
	H5	With 120°C heater

Note) Size 16 is not applicable for H4, H5, Size 25 not for H4.

⑥ Number of auto switches/Mounting position

Symbol	Quantity	Mounting position
Nil	Without auto switch	—
A	2 pcs.	Valve open/closed
B	1 pc.	Valve open
C	1 pc.	Valve closed

⑤ Auto switch type

Symbol	Auto switch model	Remarks
Nil	—	Without auto switch (without built-in magnet)
M9N(M)(L)(Z)	D-M9N(M)(L)(Z)	Solid state auto switch
M9P(M)(L)(Z)	D-M9P(M)(L)(Z)	
M9B(M)(L)(Z)	D-M9B(M)(L)(Z)	
A90(L)	D-A90(L)	Reed auto switch (Not applicable to flange size 16)
A93(M)(L)(Z)	D-A93(M)(L)(Z)	
M9//	—	Without auto switch (with built-in magnet)

Note 1) Auto switches shown above cannot be mounted on the high temperature type. For the high temperature type, a semi-standard product that uses the heat resistant auto switch D-F7NJ[®] is available. For details, please contact SMC.

Note 2) Standard lead wire length is 0.5 m. Add "L" to the end of the part number when 3 m is desired, "M" when 1 m, and "Z" when 5 m.

Example) -M9NL

⑦ Body surface treatment/Seal material and its changed part

• Body surface treatment

Symbol	Surface treatment	
	External	Internal
Nil	Hard anodized	Raw material
A	Hard anodized	Oxalic acid anodized

• Seal material

Symbol	Seal material	Compound No.
Nil	FKM	1349-80 [®]
N1	EPDM	2101-80 [®]
P1	Barrel Perfluoro [®]	70W
Q1	Kalrez [®]	4079
R1	Chemraz [®]	SS592
R2		SS630
R3		SSE38
S1	VMQ	1232-70 [®]
T1	FKM for Plasma	3310-75 [®]
U1	ULTIC ARMOR [®]	UA4640

* Produced by Mitsubishi Cable Industries, Ltd.

• Seal material changed part and leakage

Symbol	Changed part ^{Note 2)}	Leakage (Pa·m ³ /s or less) ^{Note 1)}	
		Internal	External
Nil	None	1.3 x 10 ⁻¹⁰ (FKM)	1.3 x 10 ⁻¹¹ (FKM)
A	②, ③	1.3 x 10 ⁻⁹	1.3 x 10 ⁻⁹
B	②	1.3 x 10 ⁻⁸	1.3 x 10 ⁻¹¹ (FKM)
C	③	1.3 x 10 ⁻¹⁰ (FKM)	1.3 x 10 ⁻⁹

Note 1) Values at normal temperature, excluding gas permeation.

Note 2) Refer to parts number of "Construction" on page 422 for changed part. Number indicates parts number of "Construction" accordingly.

To order something other than "Nil" (standard), list the symbols starting with "X," followed by each symbol for "body surface treatment," "seal material" and then "changed part".

Example) XLC-16-M9NA-XAN1A

Barrel Perfluoro[®] is a registered trademark of Matsumura Oil Co., Ltd. Kalrez[®] is a registered trademark of E. I. du Pont de Nemours and Company or its affiliates.

Chemraz[®] is a registered trademark of Greene, Tweed Technologies, Inc. ULTIC ARMOR[®] is a registered trademark of Nippon Valqua Industries, Ltd.

Air Operated/with Solenoid Valve

The production of flange sizes 16, 25, 40, 50, 63, and 80 for the XLC(V) series has been discontinued. Please select the new XLC(V)-2 type. See [here](#) for details.



How to Order

Flange size
16, 25, 40

XLCV - 16 [] L - [] M9N A - 1 [] G [] - [] - []

Flange size
50, 63, 80

XLCV - 50 [] - 1 [] M9N A - 1 [] G [] - [] - []

• Air operated/with solenoid valve

① Flange size

Size
16
25
40
50
63
80

② Flange type

Symbol	Type	Applicable flange
Nil	KF (NW)	16, 25, 40, 50, 63, 80
D	K (DN)	63, 80

③ Pilot port direction

Symbol	Solenoid valve direction
K	Left flange surface
L	Rear flange surface
M	Right flange surface
Nil	flange surface

- * M type plug connector (AC power supply) not attached for M of sizes 16 and 25.
- * M: Size 16, 25, 40 only.
- * Nil: Size 50, 63, 80 only.

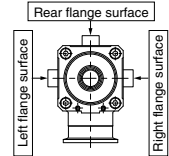

④ Auto switch type

Symbol	Auto switch model	Remarks
Nil	—	Without auto switch (without built-in magnet)
M9N(M)(L)(Z)	D-M9N(M)(L)(Z)	Solid state auto switch
M9P(M)(L)(Z)	D-M9P(M)(L)(Z)	
M9B(M)(L)(Z)	D-M9B(M)(L)(Z)	
A90(L)	D-A90(L)	Reed auto switch (Not applicable to flange size 16)
A93(M)(L)(Z)	D-A93(M)(L)(Z)	
M9//	—	Without auto switch (with built-in magnet)

Standard lead wire length is 0.5 m. Add "L" to the end of the part number when 3 m is desired, "M" when 1 m, and "Z" when 5 m.
Example -M9NL

⑤ Number of auto switches/Mounting position

Symbol	Quantity	Mounting position
Nil	Without auto switch	—
A	2 pcs.	Valve open/closed
B	1 pc.	Valve open
C	1 pc.	Valve closed

⑥ Rated voltage

	CE-compliant
1	100 VAC, 50/60 Hz —
2	200 VAC, 50/60 Hz —
3	110 VAC, 50/60 Hz —
4	220 VAC, 50/60 Hz —
5	24 VDC ○
6	12 VDC ○

⑦ Type of actuation

Nil	2 position single
W	2 position double

⑧ Electrical entry

G	Grommet (Lead wire length 300 mm)
H	Grommet (Lead wire length 600 mm)
L	L type plug connector
M	M type plug connector

⑨ Light/Surge voltage suppressor

Nil	None
S	With surge voltage suppressor
Z	With light/surge voltage suppressor
U	With light/surge voltage suppressor (Non-polar type)

- * S type: Not available for AC.
- * U type: DC only.

⑩ Body surface treatment/Seal material and its changed part

• Body surface treatment

Symbol	Surface treatment
Nil	External: Hard anodized Internal: Raw material
A	External: Hard anodized Internal: Oxalic acid anodized

• Seal material

Symbol	Seal material	Compound No.
Nil	FKM	1349-80*
N1	EPDM	2101-80*
P1	Barrel Perfluoro®	70W
Q1	Kalrez®	4079
R1	Chemraz®	SS592
R2		SS630
R3		SSE38
S1	VMQ	1232-70*
T1	FKM for Plasma	3310-75*
U1	ULTIC ARMOR®	UA4640

* Produced by Mitsubishi Cable Industries, Ltd.

• Seal material changed part and leakage

Symbol	Changed part ^{Note 2)}	Leakage (Pa·m ³ /s or less) ^{Note 1)}	
		Internal	External
Nil	None	1.3 x 10 ⁻¹⁰ (FKM)	1.3 x 10 ⁻¹¹ (FKM)
A	②, ③	1.3 x 10 ⁻⁸	1.3 x 10 ⁻⁹
B	②	1.3 x 10 ⁻⁸	1.3 x 10 ⁻¹¹ (FKM)
C	③	1.3 x 10 ⁻¹⁰ (FKM)	1.3 x 10 ⁻⁹

- Note 1) Values at normal temperature, excluding gas permeation.
- Note 2) Refer to parts number of "Construction" on page 422 for changed part. Number indicates parts number of "Construction" accordingly.

To order something other than "Nil" (standard), list the symbols starting with "X," followed by each symbol for "body surface treatment," "seal material" and then "changed part".

Example) XLCV-16-M9NA-1G-XAN1A

- Note 1) Option specifications/Combinations
This model has auto switch and K(DN) flange options, but high temperature/heater options are not available.
- Note 2) Solenoid valves

- 2 position single: XLCV-16, 25, 40; SYJ3190 XLCV-50, 63, 80, 100, 160; SY3120
- 2 position double: XLCV-16, 25, 40; SYJ3290 XLCV-50, 63, 80, 100, 160; SY3220
- Example) SYJ3190-1GS, SYJ3290-1GS, SY3120-1GS-C4, SY3220-1GS-C4
- * For details, consult your SMC sales representative.
- * For option "Q", the solenoid valve should be a CE-compliant product.

⑪ CE-compliant

Nil	—
Q	CE-compliant

Barrel Perfluoro® is a registered trademark of Matsumura Oil Co., Ltd.
Kalrez® is a registered trademark of E. I. du Pont de Nemours and Company or its affiliates.
Chemraz® is a registered trademark of Greene, Tweed Technologies, Inc.
ULTIC ARMOR® is a registered trademark of Nippon Valqua Industries, Ltd.

XLC/XLCV Series

Specifications

Model		XLC(V)-16	XLC(V)-25	XLC(V)-40	XLC(V)-50	XLC(V)-63	XLC(V)-80	XLC-100	XLC-160
Valve type		Double acting (Dual operation), Pressurize to open/close							
Fluid		Inert gas under vacuum							
Operating temperature (°C)	XLC	5 to 60 (High temperature type: 5 to 150)							
	XLCV	5 to 50							—
Operating pressure (Pa) (abs)		1 x 10 ⁻⁶ to atmospheric pressure							
Conductance (L/s) ^{Note 1)}		5	14	45	80	160	200	300	800
Leakage (Pa·m ³ /s)	Internal	In case of standard material FKM: 1.3 x 10 ⁻¹⁰ at normal temperature, excluding gas permeation							
	External	In case of standard material FKM: 1.3 x 10 ⁻¹¹ at normal temperature, excluding gas permeation							
Flange type		KF(NW)				KF (NW), K (DN)			
Principal materials		Body: Aluminum alloy, Bellows: Stainless steel 316L, Main part: Stainless steel, FKM (Standard seal material)							
Surface treatment		External: Hard anodized Internal: Raw material							
Pilot pressure (MPa) (G)		0.3 to 0.6				0.4 to 0.6			
Pilot port size	XLC	M5			Rc1/8				Rc1/4
	XLCV	M5: Port 1(P), Port 3(R), Port 5(R)							—
Weight (kg)	XLC	0.28	0.46	1.1	1.4	2.3	4.0	8.7	14.5
	XLCV	0.32	0.5	1.15	1.5	2.4	4.1	—	—

Note 1) Conductance is the value for an elbow with the same dimensions.

Note 2) For valve heater specifications, refer to "Common Option [1] Heater" on page 459.

Construction/Operation

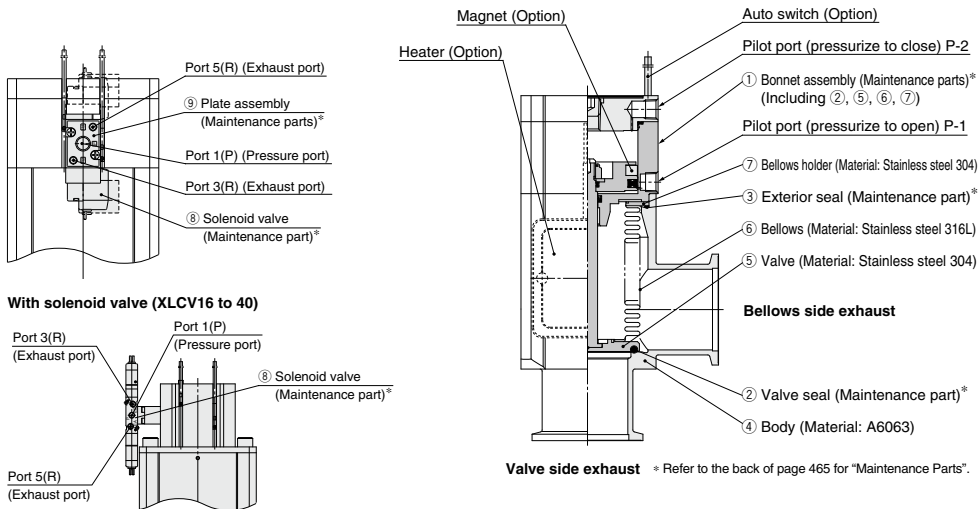

With solenoid valve (XLCV16 to 40)

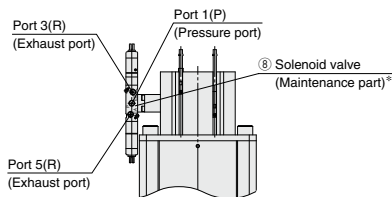

With solenoid valve (XLCV50 to 80)

<Working principle>

By applying the pilot pressure from the pilot port P-1, the piston-coupled valve overcomes the operating force by pressure, and the valve opens. (Pilot port P-2 is open.) Conversely, by applying the pilot pressure to the pilot port P-2, the valve closes. (Pilot port P-1 is open.) For the XLCV, the pilot pressure is always applied to the port 1(P), and the valve opens when the solenoid valve is turned ON and closes when it is turned OFF. For the double solenoid, the valve moves to the opposite side from that in which the solenoid valve is turned ON.

<Options>

Auto switch: The magnet activates the auto switch. With 2 auto switches, the open and closed positions are detected, and with 1 auto switch, either the open or closed position is detected. Auto switches are applicable at ordinary temperatures only (5 to 60°C).

Heater: Simple heating is performed using thermistors. The valve body can be heated to approximately 100 or 120°C, depending on the heater option and the valve size. The type and number of thermistors to be used will vary depending upon size and setting temperature. In the case of high temperature specifications, the bonnet assembly is a heat resistant structure. This does not apply in cases where a solenoid valve is attached.

Dimensions

XLC16, 25, 40/ Air operated

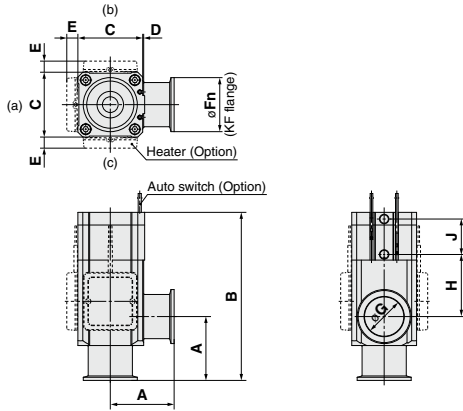

Model	A	B	C	D	E <small>Note 1)</small>	F _n	G	H	J
XLC-16	40	110	38	1	—	30	17	40	26
XLC-25	50	121	48	1	12	40	26	39	28
XLC-40	65	171	66	2	11	55	41	63	36

Note 1) Dimension E applies when heater option is included. (Lead wire length: approx. 1 m)
 Note 2) (a), (b) and (c) in the above drawing indicate heater mounting positions. Moreover, heater mounting positions will differ depending on the type of heater. For further details, refer to mounting positions under "Replacement Heaters" on page 465.

XLC50, 63, 80, 100, 160/ Air operated

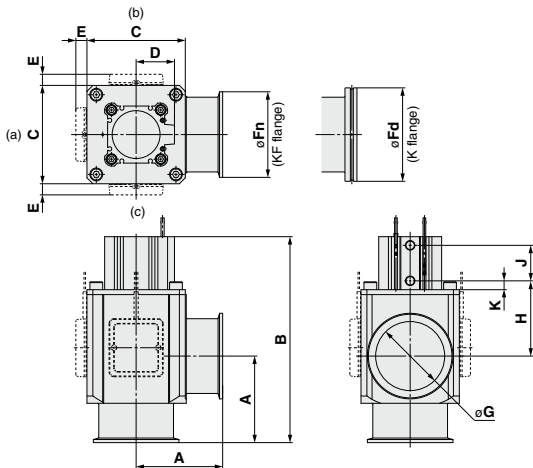

Model	A	B	C	D	E <small>Note 1)</small>	F _n	F _d	G	H	J	K
XLC-50	70	183	80	31	10.5	75	—	52	77	29	10.5
XLC-63	88	209	100	39	11	87	95	70	76.5	36	9
XLC-80	90	250	117	45.5	11	114	110	83	105	44	9
XLC-100	108	317.5	154	55	11	134	130	102	139	58	9
XLC-160	138	339	200	65	11	190	180	153	124	62	12.5

Note 1) Dimension E applies when heater option is included. (Lead wire length: approx. 1 m)
 Note 2) (a), (b) and (c) in the above drawing indicate heater mounting positions. Moreover, heater mounting positions will differ depending on the type of heater. For further details, refer to mounting positions under "Replacement Heaters" on page 465.

- XLA**
- XL□**
- XL□Q**
- XM□**
- XY□**
- D-□**
- XSA**
- XVD**
- XGT**
- CYV**

XLC/XLCV Series

Dimensions

XLCV/With solenoid valve

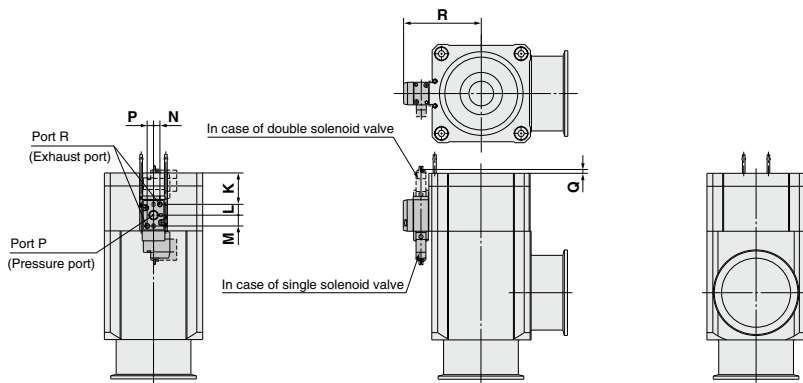

(mm)

Model	K	L	M	N	P	Q	R
XLCV-16	14.3	9.2	6.4	3.5	2.7	17.3	36
XLCV-25	15.8	9.2	6.4	3.5	2.7	15.8	41
XLCV-40	29	9.2	6.4	3.5	2.7	2.6	51

* Other dimensions are the same as the XLC.
 (Note) For details, consult your SMC sales representative.

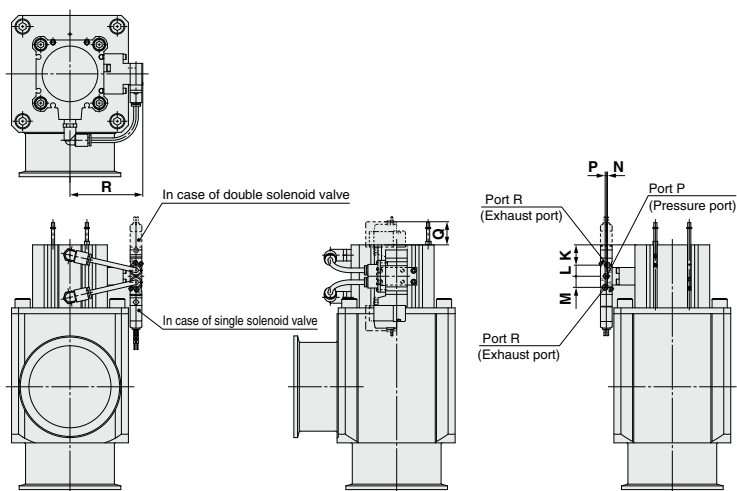

(mm)

Model	K	L	M	N	P	Q	R
XLCV-50	12.5	9.5	9.5	1	1	23.5	52.6
XLCV-63	17.4	9.5	9.5	1	1	18.6	62.3
XLCV-80	23.5	9.5	9.5	1	1	12.4	70.8

* Other dimensions are the same as the XLC.
 (Note) For details, consult your SMC sales representative.

XLA
XL □
XL□Q
XM□ XY□
D-□
XSA
XVD
XGT
CYV

Aluminum High Vacuum Angle Valve Normally Closed/O-ring Seal

The production of flange sizes 16, 25, 40, 50, 63, and 80 for the XLF(V) series has been discontinued. Please select the new XLF(V)-2 type. See [here](#) for details.

RoHS

XLF/XLFV Series



XLF

How to Order



Made to Order specifications
(For details, refer to pages 430 to 435)

XLF - **16** - **M9N A** -

① ② ③ ④ ⑤ ⑥ ⑦

① Flange size

Size
16
25
40
50
63
80
100
160

② Flange type

Symbol	Type	Applicable flange
Nil	KF (NW)	16, 25, 40, 50, 63 80, 100, 160
D	K (DN)	63, 80, 100, 160

③ Indicator/Pilot port direction

Symbol	Indicator	Pilot port direction
Nil	Without indicator	Flange side
A		Flange side
F	With indicator	Left flange surface
G		Rear flange surface
J		Right flange surface
K	Without indicator	Left flange surface
L		Rear flange surface
M		Right flange surface

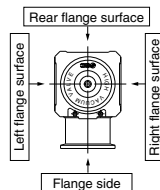

④ Temperature specifications/Heater

Symbol	Temperature	Heater	
Nil	5 to 60°C	—	
High temperature type	H0	—	
	H4	5 to 150°C	With 100°C heater
	H5		With 120°C heater

Note) Size 16 is not applicable for H4, H5, Size 25 not for H4.

⑥ Number of auto switches/Mounting position

Symbol	Quantity	Mounting position
Nil	Without auto switch	—
A	2 pcs.	Valve open/closed
B	1 pc.	Valve open
C	1 pc.	Valve closed

⑤ Auto switch type

Symbol	Auto switch model	Remarks
Nil	—	Without auto switch (without built-in magnet)
M9N(M)(L)(Z)	D-M9N(M)(L)(Z)	Solid state auto switch
M9P(M)(L)(Z)	D-M9P(M)(L)(Z)	
M9B(M)(L)(Z)	D-M9B(M)(L)(Z)	
A90(L)	D-A90(L)	Reed auto switch (Not applicable to flange size 16)
A93(M)(L)(Z)	D-A93(M)(L)(Z)	
M9//	—	Without auto switch (with built-in magnet)

Note 1) Auto switches shown above cannot be mounted on the high temperature type. For the high temperature type, a semi-standard product that uses the heat resistant auto switch D-F7NJ[®] is available. For details, please contact SMC.

Note 2) Standard lead wire length is 0.5 m. Add "L" to the end of the part number when 3 m is desired, "M" when 1 m, and "Z" when 5 m.

Example) -M9NL

⑦ Body surface treatment/Seal material and its changed part

• Body surface treatment

Symbol	Surface treatment
Nil	External: Hard anodized Internal: Raw material
A	External: Hard anodized Internal: Oxalic acid anodized

• Seal material

Symbol	Seal material	Compound No.
Nil	FKM	1349-80*
N1	EPDM	2101-80*
P1	Barrel Perfluoro [®]	70W
Q1	Kalrez [®]	4079
R1		SS592
R2		SS630
R3	Chemraz [®]	SSE38
S1	VMQ	1232-70*
T1	FKM for Plasma	3310-75*
U1	ULTIC ARMOR [®]	UA4640

* Produced by Mitsubishi Cable Industries, Ltd.

• Seal material changed part and leakage

Symbol	Changed part ^{Note 2)}	Leakage (Pa·m ³ /s or less) ^{Note 1)}	
		Internal	External
Nil	None	1.3 x 10 ⁻¹⁰ (FKM)	1.3 x 10 ⁻¹⁰ (FKM)
A	②, ③	1.3 x 10 ⁻⁸	1.3 x 10 ⁻⁸
B	②	1.3 x 10 ⁻⁸	1.3 x 10 ⁻¹⁰ (FKM)
C	③	1.3 x 10 ⁻¹⁰ (FKM)	1.3 x 10 ⁻⁸

Note 1) Values at normal temperature, excluding gas permeation.

Note 2) Refer to parts number of "Construction" on page 428 for changed part. Number indicates parts number of "Construction" accordingly.

Note 3) Part ③ (exterior seal) is not changeable for sizes 16 and 25.

To order something other than "Nil" (standard), list the symbols starting with "X," followed by each symbol for "body surface treatment," "seal material" and then "changed part".

Example) XLF-40-M9NA-XAN1A

Barrel Perfluoro[®] is a registered trademark of Matsumura Oil Co., Ltd.
Kalrez[®] is a registered trademark of E. I. du Pont de Nemours and Company or its affiliates.
Chemraz[®] is a registered trademark of Greene, Tweed Technologies, Inc.
ULTIC ARMOR[®] is a registered trademark of Nippon Valqua Industries, Ltd.

Air Operated/with Solenoid Valve

The production of flange sizes 16, 25, 40, 50, 63, and 80 for the XLF(V) series has been discontinued. Please select the new XLF(V)-2 type. See [here](#) for details.

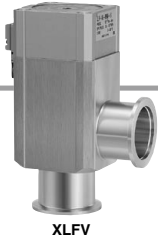

How to Order

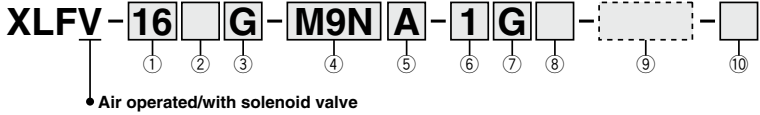

① Flange size

Size
16
25
40
50
63
80
100
160

② Flange type

Symbol	Type	Applicable flange
NII	KF (NW)	16, 25, 40, 50, 63
D	K (DN)	63, 80, 100, 160

③ Indicator/Pilot port direction

Symbol	Indicator	Pilot port direction
F	With indicator	Left flange surface
		Rear flange surface
		Right flange surface
J	Without indicator	Left flange surface
		Rear flange surface
		Right flange surface
M		

* M type plug connector (AC power supply) not attached for J, M of sizes 16 and 25.

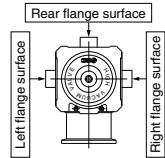

④ Auto switch type

Symbol	Auto switch model	Remarks
NII	—	Without auto switch (without built-in magnet)
M9N(M)(L)(Z)	D-M9N(M)(L)(Z)	Solid state auto switch
M9P(M)(L)(Z)	D-M9P(M)(L)(Z)	
M9B(M)(L)(Z)	D-M9B(M)(L)(Z)	
A90(L)	D-A90(L)	Reed auto switch (Not applicable to flange size 16)
A93(M)(L)(Z)	D-A93(M)(L)(Z)	
M9//	—	Without auto switch (with built-in magnet)

Standard lead wire length is 0.5 m. Add "L" to the end of the part number when 3 m is desired, "M" when 1 m, and "Z" when 5 m.

Example) -M9N_L

⑤ Number of auto switches/Mounting position

Symbol	Quantity	Mounting position
NII	Without auto switch	—
A	2 pcs.	Valve open/closed
B	1 pc.	Valve open
C	1 pc.	Valve closed

⑥ Rated voltage

		CE-compliant
1	100 VAC, 50/60 Hz	—
2	200 VAC, 50/60 Hz	—
3	110 VAC, 50/60 Hz	—
4	220 VAC, 50/60 Hz	—
5	24 VDC	○
6	12 VDC	○

⑦ Electrical entry

G	Grommet (Lead wire length 300 mm)
H	Grommet (Lead wire length 600 mm)
L	L type plug connector
M	M type plug connector

⑧ Light/Surge voltage suppressor

NII	None
S	With surge voltage suppressor
Z	With light/surge voltage suppressor
U	With light/surge voltage suppressor (Non-polar type)

* S type: Not available for AC.
* U type: DC only.

⑩ CE-compliant

NII	—
Q	CE-compliant

⑨ Body surface treatment/Seal material and its changed part

• Body surface treatment

Symbol	Surface treatment	
NII	External: Hard anodized	Internal: Raw material
A	External: Hard anodized	Internal: Oxalic acid anodized

• Seal material

Symbol	Seal material	Compound No
NII	FKM	1349-80*
N1	EPDM	2101-80*
P1	Barrel Perfluoro®	70W
Q1	Kalrez®	4079
R1	Chemraz®	SS592
R2		SS630
R3		SS538
S1	VMQ	1232-70*
T1	FKM for Plasma	3310-75*
U1	ULTIC ARMOR®	UA4640

* Produced by Mitsubishi Cable Industries, Ltd.

• Seal material changed part and leakage

Symbol	Changed part ^{Note 2)}	Leakage (Pa·m ³ /s or less) ^{Note 1)}	
		Internal	External
NII	None	1.3 x 10 ⁻¹⁰ (FKM)	1.3 x 10 ⁻¹⁰ (FKM)
A	②, ③	1.3 x 10 ⁻⁸	1.3 x 10 ⁻⁸
B	②	1.3 x 10 ⁻⁸	1.3 x 10 ⁻¹⁰ (FKM)
C	③	1.3 x 10 ⁻¹⁰ (FKM)	1.3 x 10 ⁻⁸

Note 1) Values at normal temperature, excluding gas permeation.

Note 2) Refer to parts number of "Construction" on page 428 for changed part.

Number indicates parts number of "Construction" accordingly.

Note 3) Part ③ (exterior seal) is not changeable for sizes 16 and 25.

To order something other than "NII" (standard), list the symbols starting with "X", followed by each symbol for "body surface treatment," "seal material" and then "changed part".

Example) XLFV-40-M9NA-1G-XAN1A

Note 1) Option specifications/Combinations

This model has indicator, auto switch and K(DN) flange options, but high temperature/heater options are not available.

Note 2) Solenoid valves

XLFV-16, 25, 40; SYJ319, XLFV-50, 63, 80, 100, 160; SYJ319

Example) SYJ319-1GS.

* For details, consult your SMC sales representative.

* For option "Q", the solenoid valve should be a CE-compliant product.

Barrel Perfluoro® is a registered trademark of Matsumura Oil Co., Ltd.
Kalrez® is a registered trademark of E. I. du Pont de Nemours and Company or its affiliates.

Chemraz® is a registered trademark of Greene, Tweed Technologies, Inc.

ULTIC ARMOR® is a registered trademark of Nippon Valqua Industries, Ltd.

XLF/XLFV Series

Specifications

Model	XLF(V)-16	XLF(V)-25	XLF(V)-40	XLF(V)-50	XLF(V)-63	XLF(V)-80	XLF(V)-100	XLF(V)-160	
Valve type	Normally closed (Pressurize to open, Spring seal)								
Fluid	Inert gas under vacuum								
Operating temperature (°C)	XLF	5 to 60 (High temperature type: 5 to 150)							
	XLFV	5 to 50							
Operating pressure (Pa) (abs)	1 x 10 ⁻⁶ to atmospheric pressure								
Conductance (L/s) ^{Note 1)}	5	14	45	80	160	200	300	800	
Leakage (Pa·m ³ /s)	Internal	In case of standard material FKM: 1.3 x 10 ⁻¹⁰ at normal temperature, excluding gas permeation							
	External	In case of standard material FKM: 1.3 x 10 ⁻¹⁰ at normal temperature, excluding gas permeation							
Flange type	KF (NW)				KF (NW), K (DN)				
Principal materials ^{Note 3)}	Body: Aluminum alloy, Main part: Stainless steel, FKM (Standard seal material)								
Surface treatment	External: Hard anodized				Internal: Raw material				
Pilot pressure (MPa) (G)	0.4 to 0.7								
Pilot port size	XLF	M5			Rc1/8				Rc1/4
	XLFV	M5: Port 1(P), Port 3(R)			Rc1/8: Port 1(P), M5: Port 3(R)				
Weight (kg)	XLF	0.25	0.45	1.1	1.6	3.0	4.8	10	18
	XLFV	0.29	0.49	1.14	1.66	3.06	4.86	10.1	18.1

Note 1) Conductance is the value for an elbow with the same dimensions.

Note 2) For valve heater specifications, refer to "Common Option [1] Heater" on page 459.

Note 3) A coating of vacuum grease [Y-VAC2] is applied to the seal-material sliding portion of the vacuum part.

Construction/Operation

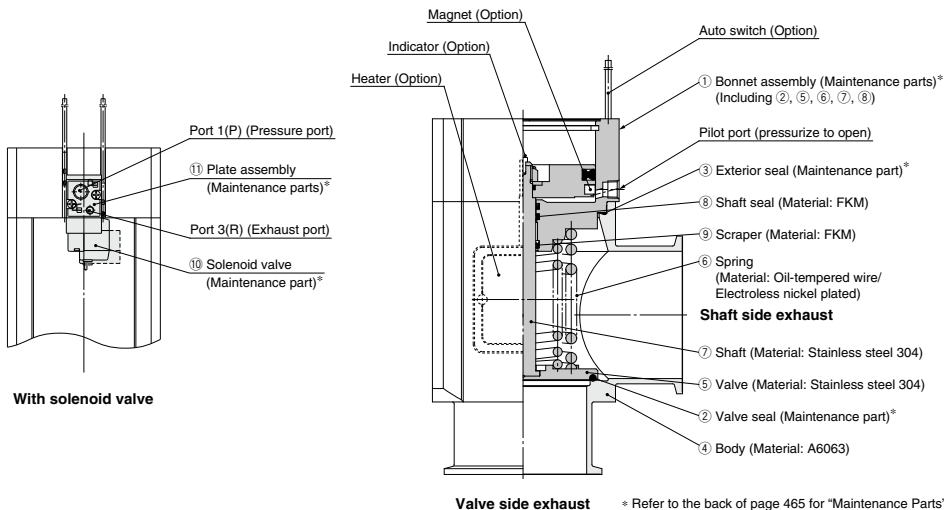

<Working principle>

By applying the pilot pressure from the pilot port, the piston-coupled valve overcomes the spring force or operating force by pressure, and the valve opens. For the XLFV, the pilot pressure is always applied to the port 1(P), and the valve opens when the solenoid valve is turned ON and closes when it is turned OFF.

<Options>

Auto switch: The magnet activates the auto switch. With 2 auto switches, the open and closed positions are detected, and with 1 auto switch, either the open or closed position is detected. Auto switches are applicable at ordinary temperatures only (5 to 60°C).

Heater: Simple heating is performed using thermistors. The valve body can be heated to approximately 100 or 120°C, depending on the heater option and the valve size. The type and number of thermistors to be used will vary depending upon size and setting temperature. In the case of high temperature specifications, the bonnet assembly is a heat resistant structure. This does not apply in cases where a solenoid valve is attached.

Indicator: When the valve is open, an orange marker appears in the center of the name plate.

Dimensions

XLF/Air operated

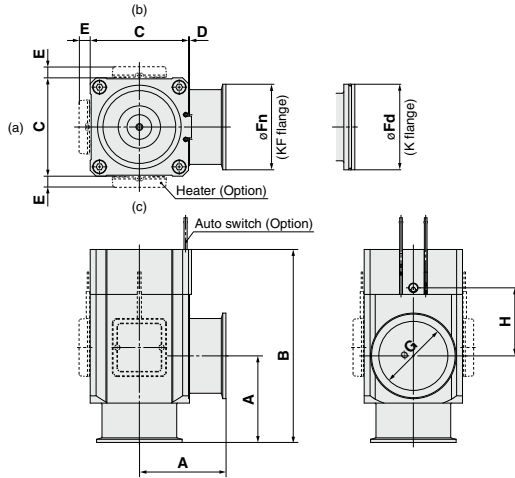

Model	A	B	C	D	E (Note 1)	Fn	Fd	G	H
XLF-16	40	103	38	1	—	30	—	17	40
XLF-25	50	113	48	1	12	40	—	26	39
XLF-40	65	158	66	2	11	55	—	41	63
XLF-50	70	170	79	2	11	75	—	52	68
XLF-63	88	196	100	3	11	87	95	70	69
XLF-80	90	235	117	3	11	114	110	83	96
XLF-100	108	299	154	3	11	134	130	102	131
XLF-160	138	315	200	3	11	190	180	153	112

Note 1) Dimension E applies when heater option is included. (Lead wire length: approx. 1 m)
 Note 2) (a), (b) and (c) in the above drawing indicate heater mounting positions.

Moreover, heater mounting positions will differ depending on the type of heater.

For further details, refer to mounting positions under "Replacement Heaters" on page 465.

XLFV/With solenoid valve

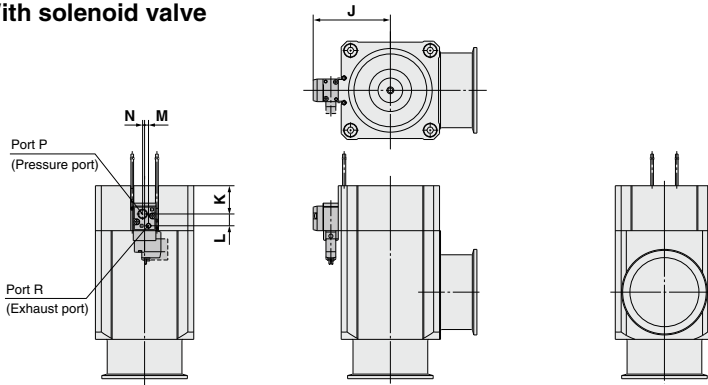

Model	J	K	L	M	N
XLFV-16	35.5	12.3	10.2	3.6	3.6
XLFV-25	40.5	13.8	10.2	3.6	3.6
XLFV-40	50.5	21.6	10.2	3.6	3.6
XLFV-50	67	21.7	12	4	2

* Other dimensions are the same as the XLF.
 Note) For details, consult your SMC sales representative.

Model	J	K	L	M	N
XLFV-63	78.5	28.7	12	4	2
XLFV-80	87	38.7	12	4	2
XLFV-100	105.5	49.7	12	4	2
XLFV-160	128.5	58	12	4	2

* Other dimensions are the same as the XLF.
 Note) For details, consult your SMC sales representative.

XLA

XL□

XL□Q

XM□

XY□

D-□

XSA

XVD

XGT

CYV

How to Order Valve

XLFR-80 [] [] [] - **M9N** **A** - **1K** - **X** [] [] []

Main valve: Indicator/Pilot port direction

Symbol	Indicator	Pilot port direction
NII	Without indicator	Flange side
A	With indicator	Flange side
F		Left flange surface
G		Rear flange surface
J		Right flange surface
K	Without indicator	Left flange surface
L		Rear flange surface
M		Right flange surface

Temperature specifications

Symbol	Temperature
NII	5 to 60°C
HO	5 to 150°C

Seal material

Symbol	Seal material	Compound No.
NII	FKM	1349-80
N1	EPDM	2101-80
P1	Barrel Perfluoro®	70W
Q1	Kalrez®	4079
R1	Chemraz®	SS592
R2		SS630
R3		SSE38
S1	VMQ	1232-70
T1	FKM FOR PLASMA	3310-75
U1	ULTIC ARMOR®	UA4640

Auto switch type (Operating temperature 5 to 60°C)

Symbol	Auto switch model	Switch type
NII	—	Without auto switch (without built-in magnet)
M9N(M)(L)(Z)	D-M9N(M)(L)(Z)	Solid state auto switch
M9P(M)(L)(Z)	D-M9P(M)(L)(Z)	
M9B(M)(L)(Z)	D-M9B(M)(L)(Z)	
A90(L)	D-A90(L)	Reed auto switch
A93(M)(L)(Z)	D-A93(M)(L)(Z)	
M9//	Without auto switch (with built-in magnet)	

Bypass valve mounting position/Pilot port direction

Symbol	Mounting position	Symbol	Pilot port direction
1	Left flange surface	NII	Flange side
		K	Left flange surface
		L	Rear flange surface
2	Right flange surface	NII	Flange side
		L	Rear flange surface
		M	Right flange surface
3	Rear flange surface	K	Left flange surface
		L	Rear flange surface
		M	Right flange surface

Barrel Perfluoro® is a registered trademark of Matsumura Oil Co., Ltd. Kalrez® is a registered trademark of E. I. du Pont de Nemours and Company or its affiliates. Chemraz® is a registered trademark of Greene, Tweed Technologies, Inc. ULTIC ARMOR® is a registered trademark of Nippon Valqua Industries, Ltd.

Note 1) Standard lead wire length is 0.5 m. Add "L" to the end of the part number when 3 m is desired, "M" when 1 m, and "Z" when 5 m.
 Note 2) Types with auto switches are not available in case of high temperature types.
 Note 3) A type with a pre-wired connector is also selectable. Example) M9NSAPC
 Note 4) Refer to the **Auto Switch Catalog** for further information on auto switches.

When the seal material is not being changed, there is no need to select a symbol.

Flange type

Symbol	Type
NII	KF(NW)
D	K(DN)

Number of auto switches/Mounting position

Symbol	Quantity	Mounting position
NII	Without auto switch	—
A	2 pcs.	Valve open/closed
B	1 pc.	Valve open
C	1 pc.	Valve closed

Seal material changed part

Symbol	Changed part	Leakage (Pa·m ³ /s or less) (Note)	
		Internal	External
NII	None	1.3 x 10 ⁻⁹ (FKM)	1.3 x 10 ⁻⁹ (FKM)
A	(2-1)(8-1)(4)(8-2)(9)	1.3 x 10 ⁻⁷	1.3 x 10 ⁻⁷
B	(2-1)(8-1)	1.3 x 10 ⁻⁷	1.3 x 10 ⁻⁹ (FKM)
C	(4)(8-2)(9)	1.3 x 10 ⁻⁹ (FKM)	1.3 x 10 ⁻⁷

Note) Values at normal temperature, excluding gas permeation.

Maintenance Parts

② **Bonnet Assembly Part No.**

XLF80A-30-1H - **M9NA-XN1**

Bonnet assembly

Temperature	Indicator	Part no.
5 to 60°C	Without indicator	XLF80-30-1
	With indicator	XLF80A-30-1
5 to 150°C	Without indicator	XLF80-30-1H
	With indicator	XLF80A-30-1H

⑧ **Bypass Valve Part No.**

XLA-16 [] [] - [] [] - **X65**

Pilot port direction

Symbol	Pilot port direction
NII	Rear (as seen from body connection point)
K	Left (as seen from body connection point)
M	Right (as seen from body connection point)

Seal material changed part

Symbol	Changed part
NII	None
A	(8-1)(8-2)
B	(8-1)
C	(8-2)

Same as How to Order

Temperature specifications

Symbol	Temperature
NII	5 to 60°C
HO	5 to 150°C

Seal material: Same as the seal materials of How to Order Valve

Specifications

Valve type	Main valve: Normally closed	Bypass valve: Normally closed
Shaft seal type	O-ring seal	Bellows seal
Operating pressure range	Atmospheric pressure to 1 x 10 ⁵ Pa	
Fluid	Inert gas under vacuum	
Operating temperature	5 to 60°C (Option: 5 to 150°C)	
Conductance	200 L/s	Max. 25 L/s (Calculated value)
Operating pressure	0.4 to 0.7 MPa	
Flange	KF80	

How to Order Valve

XLFR-100 [] [] [] - **M9N** **A** - **1K** - **X** [] []

Flange type

Symbol	Type
Nil	KF(NW)
D	K(DN)

Temperature specifications

Symbol	Temperature
Nil	5 to 60°C
HO	5 to 150°C

Seal material

Symbol	Seal material	Compound No.
Nil	FKM	1349-80
N1	EPDM	2101-80
P1	Barrel Perfluoro [®]	70W
Q1	Kalrez [®]	4079
R1	Chemraz [®]	SS592
R2		SS630
R3		SSE38
S1	VMQ	1232-70
T1	FKM FOR PLASMA	3310-75
U1	ULTIC ARMOR [®]	UA4640

**Main valve: Indicator/
Pilot port direction**

Symbol	Indicator	Pilot port direction
Nil	Without indicator	Flange side
A	With indicator	Flange side
F		Left flange surface
G		Rear flange surface
J		Right flange surface
K	Without indicator	Left flange surface
L		Rear flange surface
M		Right flange surface

Number of auto switches/Mounting position

Symbol	Quantity	Mounting position
Nil	Without auto switch	—
A	2 pcs.	Valve open/closed
B	1 pc.	Valve open
C	1 pc.	Valve closed

Bypass valve mounting position/Pilot port direction

Symbol	Mounting position	Symbol	Pilot port direction
1	Left flange surface	Nil	Flange side
		K	Left flange surface
		L	Rear flange surface
2	Right flange surface	Nil	Flange side
		L	Rear flange surface
		M	Right flange surface
3	Rear flange surface	K	Left flange surface
		L	Rear flange surface
		M	Right flange surface

Barrel Perfluoro[®] is a registered trademark of Matsumura Oil Co., Ltd.
Kalrez[®] is a registered trademark of E. I. du Pont de Nemours and Company or its affiliates.
Chemraz[®] is a registered trademark of Greene, Tweed Technologies, Inc.
ULTIC ARMOR[®] is a registered trademark of Nippon Valqua Industries, Ltd.

* Flange: (A)

Auto switch type

Symbol	Auto switch model	Switch type
Nil	—	Without auto switch (without built-in magnet)
M9N(M)(L)(Z)	D-M9N(M)(L)(Z)	Solid state auto switch
M9P(M)(L)(Z)	D-M9P(M)(L)(Z)	
M9B(M)(L)(Z)	D-M9B(M)(L)(Z)	
A90(L)	D-A90(L)	Reed auto switch
A93(M)(L)(Z)	D-A93(M)(L)(Z)	
M9/	Without auto switch (with built-in magnet)	

Note 1) Standard lead wire length is 0.5 m. Add "L" to the end of the part number when 3 m is desired, "M" when 1 m, and "Z" when 5 m.

Note 2) Types with auto switches are not available in case of high temperature types.

Note 3) A type with a pre-wired connector is also selectable. Example -M9NSAPC

Note 4) Refer to the [Auto Switch Catalog](#) for further information on auto switches.

* Flange: (A)

When the seal material is not being changed, there is no need to select a symbol.

Seal material changed part

Symbol	Changed part	Leakage (Pa·m ³ /s or less) (Note)	
		Internal	External
Nil	None	1.3 x 10 ⁻⁹ (FKM)	1.3 x 10 ⁻⁹ (FKM)
A	(2-1)(8-1)(4)(8-2)(9)	1.3 x 10 ⁻⁷	1.3 x 10 ⁻⁷
B	(2-1)(8-1)	1.3 x 10 ⁻⁷	1.3 x 10 ⁻⁹ (FKM)
C	(4)(8-2)(9)	1.3 x 10 ⁻⁹ (FKM)	1.3 x 10 ⁻⁷

Note) Values at normal temperature, excluding gas permeation.

Maintenance Parts

② **Bonnet Assembly Part No.**

XLF100A-30-1 - **M9NA-XN1**

Bonnet assembly

Temperature	Indicator	Part no.
5 to 60°C	Without indicator	XLF100-30-1
	With indicator	XLF100A-30-1
5 to 150°C	Without indicator	XLF100-30-1H
	With indicator	XLF100A-30-1H

Same as How to Order

⑧ **Bypass Valve Part No.**

XLA-16 [] [] - [] [] - **X65**

Pilot port direction

Symbol	Pilot port direction
Nil	Rear (as seen from body connection point)
K	Left (as seen from body connection point)
M	Right (as seen from body connection point)

Temperature specifications

Symbol	Temperature
Nil	5 to 60°C
HO	5 to 150°C

Seal material changed part

Symbol	Changed part
Nil	None
A	(8-1)(8-2)
B	(8-1)
C	(8-2)

Seal material: Same as the seal materials of How to Order Valve

Specifications

Valve type	Main valve: Normally closed	Bypass valve: Normally closed
Shaft seal type	O-ring seal	Bellows seal
Operating pressure range	Atmospheric pressure to 1 x 10 ⁻⁵ Pa	
Fluid	Inert gas under vacuum	
Operating temperature	5 to 60°C (Option: 5 to 150°C)	
Conductance	300 L/s	Max. 31.5 L/s (Calculated value)
Operating pressure	0.4 to 0.7 MPa	
Flange	KF100	

XLA

XL□

XL□Q

XM□

XY□

D-□

XSA

XVD

XGT

CVV



Please contact SMC for detailed dimensions, specifications and lead times.

With Bypass Valve (Flange size: 160)

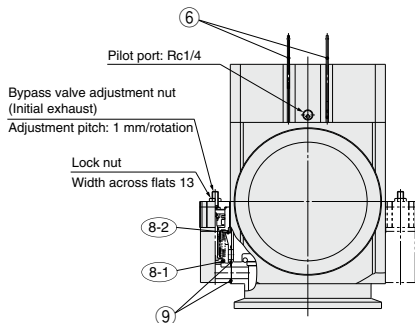
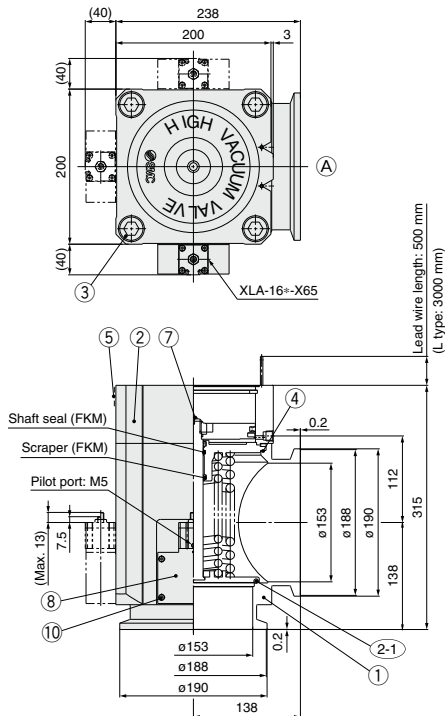

Symbol



Component Parts

No.	Description	Material	Remarks
1	Body	A6063	
2	Bonnet assembly		Refer to part no.
2-1	O-ring		Refer to part no.
3	Hexagon socket head cap screw	Stainless steel	M20, L = 70
4	O-ring		Refer to part no.
5	Computer name plate		
6	Auto switch		Option
7	Indicator		Option
8	Bypass valve		Refer to part no.
8-1	O-ring		Refer to part no.
8-2	O-ring		Refer to part no.
9	O-ring		Refer to part no.
10	Hexagon socket head cap screw	Stainless steel	M4, L = 40

O-ring Part No.

Seal material symbol	Internal seal (2-1)	External seal (4)
NII	B2401-G155V	AS568-167V
N1	B2401-G155-XN1	AS568-167-XN1
P1	B2401-G155-XP1	AS568-167-XP1
Q1	B2401-G155-XQ1	AS568-167-XQ1
R1	B2401-G155-XR1	AS568-167-XR1
R2	B2401-G155-XR2	AS568-167-XR2
R3	B2401-G155-XR3	AS568-167-XR3
S1	B2401-G155-XS1	AS568-167-XS1
T1	B2401-G155-XT1	AS568-167-XT1
U1	B2401-G155-XU1	AS568-167-XU1

O-ring Part No.

Seal material symbol	Internal seal (8-1)	External seal (8-2)	External seal (9)
NII	B2401-V15V	AS568-025V	AS568-017V
N1	B2401-V15-XN1	AS568-025-XN1	AS568-017-XN1
P1	B2401-V15-XP1	AS568-025-XP1	AS568-017-XP1
Q1	B2401-V15-XQ1	AS568-025-XQ1	AS568-017-XQ1
R1	B2401-V15-XR1	AS568-025-XR1	AS568-017-XR1
R2	B2401-V15-XR2	AS568-025-XR2	AS568-017-XR2
R3	B2401-V15-XR3	AS568-025-XR3	AS568-017-XR3
S1	B2401-V15-XS1	AS568-025-XS1	AS568-017-XS1
T1	B2401-V15-XT1	AS568-025-XT1	AS568-017-XT1
U1	B2401-V15-XU1	AS568-025-XU1	AS568-017-XU1

Note) A coating of vacuum grease (fluorinated grease: Y-VAC2) is applied to the shaft seal, scraper and O-ring (9).

How to Order Valve

XLFR-160 [] [] [] - **M9N** **A** - **1K** - **X** [] []

Flange type

Symbol	Type
Nil	KF(NW)
D	K(DN)

Temperature specifications

Symbol	Temperature
Nil	5 to 60°C
HO	5 to 150°C

Seal material

Symbol	Seal material	Compound No.
Nil	FKM	1349-80
N1	EPDM	2101-80
P1	Barrel Perfluoro®	70W
Q1	Kalrez®	4079
R1	Chemraz®	SS592
R2		SS630
R3		SSE38
S1	VMQ	1232-70
T1	FKM FOR PLASMA	3310-75
U1	ULTIC ARMOR®	UA4640

**Main valve: Indicator/
Pilot port direction**

Symbol	Indicator	Pilot port direction
Nil	Without indicator	Flange side
A	With indicator	Flange side
F		Left flange surface
G		Rear flange surface
J		Right flange surface
K	Without indicator	Left flange surface
L		Rear flange surface
M		Right flange surface

Number of auto switches/Mounting position

Symbol	Quantity	Mounting position
Nil	Without auto switch	—
A	2 pcs.	Valve open/closed
B	1 pc.	Valve open
C	1 pc.	Valve closed

Bypass valve mounting position/Pilot port direction

Symbol	Mounting position	Symbol	Pilot port direction
1	Left flange surface	Nil	Flange side
		K	Left flange surface
		L	Rear flange surface
2	Right flange surface	Nil	Flange side
		M	Rear flange surface
		L	Right flange surface
3	Rear flange surface	K	Left flange surface
		L	Rear flange surface
		M	Right flange surface

Barrel Perfluoro® is a registered trademark of Matsumura Oil Co., Ltd. Kalrez® is a registered trademark of E. I. du Pont de Nemours and Company or its affiliates. Chemraz® is a registered trademark of Greene, Tweed Technologies, Inc. ULTIC ARMOR® is a registered trademark of Nippon Valqua Industries, Ltd.

* Flange: (A)

Auto switch type

Symbol	Auto switch model	Switch type
Nil	—	Without auto switch (without built-in magnet)
M9N(M)(L)(Z)	D-M9N(M)(L)(Z)	Solid state auto switch
M9P(M)(L)(Z)	D-M9P(M)(L)(Z)	
M9B(M)(L)(Z)	D-M9B(M)(L)(Z)	
A90(L)	D-A90(L)	Reed auto switch
A93(M)(L)(Z)	D-A93(M)(L)(Z)	
M9//	Without auto switch (with built-in magnet)	

Note 1) Standard lead wire length is 0.5 m. Add "L" to the end of the part number when 3 m is desired, "M" when 1 m, and "Z" when 5 m.

Note 2) Types with auto switches are not available in case of high temperature types.

Note 3) A type with a pre-wired connector is also selectable. Example: -M9NSAPC

Note 4) Refer to the **Auto Switch Catalog** for further information on auto switches.

* Flange: (A)

When the seal material is not being changed, there is no need to select a symbol.

Seal material changed part

Symbol	Changed part	Leakage (Pa·m ³ /s or less) (Note)	
		Internal	External
Nil	None	1.3 x 10 ⁻⁹ (FKM)	1.3 x 10 ⁻⁹ (FKM)
A	(2-1)(8-1)(4)(8-2)(9)	1.3 x 10 ⁻⁷	1.3 x 10 ⁻⁷
B	(2-1)(8-1)	1.3 x 10 ⁻⁷	1.3 x 10 ⁻⁹ (FKM)
C	(4)(8-2)(9)	1.3 x 10 ⁻⁹ (FKM)	1.3 x 10 ⁻⁷

Note) Values at normal temperature, excluding gas permeation.

Maintenance Parts

② **Bonnet Assembly Part No.**

XLF160A-30-1 - M9NA-XN1

Bonnet assembly

Temperature	Indicator	Part no.
5 to 60°C	Without indicator	XLF160-30-1
	With indicator	XLF160A-30-1
5 to 150°C	Without indicator	XLF160-30-1H
	With indicator	XLF160A-30-1H

Same as How to Order

⑧ **Bypass Valve Part No.**

XLA-16 [] [] - [] [] - **X65**

Pilot port direction

Symbol	Pilot port direction
Nil	Rear (as seen from body connection point)
K	Left (as seen from body connection point)
M	Right (as seen from body connection point)

Seal material changed part

Symbol	Changed part
Nil	None
A	(8-1)(8-2)
B	(8-1)
C	(8-2)

Temperature specifications

Symbol	Temperature
Nil	5 to 60°C
HO	5 to 150°C

Seal material: Same as the seal materials of How to Order Valve

Specifications

Valve type	Main valve: Normally closed	Bypass valve: Normally closed
Shaft seal type	O-ring seal	Bellows seal
Operating pressure range	Atmospheric pressure to 1 x 10 ⁵ Pa	
Fluid	Inert gas under vacuum	
Operating temperature	5 to 60°C (Option: 5 to 150°C)	
Conductance	800 L/s	Max. 31.5 L/s (Calculated value)
Operating pressure	0.4 to 0.7 MPa	
Flange	KF160	

Aluminum High Vacuum Angle Valve Double Acting/O-ring Seal

The production of flange sizes 16, 25, 40, 50, 63, and 80 for the XLG(V) series has been discontinued. Please select the new XLG(V)-2 type. See [here](#) for details.

RoHS

XLG/XLGV Series



How to Order



Made to Order specifications
(For details, refer to pages 442 to 447)

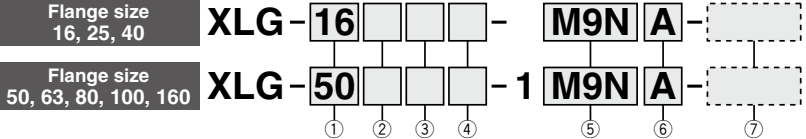

① Flange size

Size
16
25
40
50
63
80
100
160

② Flange type

Symbol	Type	Applicable flange
Nil	KF (NW)	16, 25, 40, 50 63, 80, 100, 160
D	K (DN)	63, 80, 100, 160

③ Pilot port direction

Symbol	Pilot port direction
Nil	Flange side
K	Left flange surface
L	Rear flange surface
M	Right flange surface

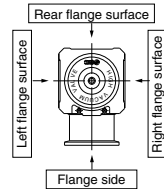

④ Temperature specifications/Heater

Symbol	Temperature	Heater	
Nil	5 to 60°C	—	
High temperature type	H0	—	
	H4	5 to 150°C	With 100°C heater
	H5	—	With 120°C heater

Note) Size 16 is not applicable for H4, H5, Size 25 not for H4.

⑥ Number of auto switches/Mounting position

Symbol	Quantity	Mounting position
Nil	Without auto switch	—
A	2 pcs.	Valve open/closed
B	1 pc.	Valve open
C	1 pc.	Valve closed

⑤ Auto switch type

Symbol	Auto switch model	Remarks
Nil	—	Without auto switch (without built-in magnet)
M9N(M)(L)(Z)	D-M9N(M)(L)(Z)	Solid state auto switch
M9P(M)(L)(Z)	D-M9P(M)(L)(Z)	
M9B(M)(L)(Z)	D-M9B(M)(L)(Z)	
A90(L)	D-A90(L)	Reed auto switch (Not applicable to flange size 16)
A93(M)(L)(Z)	D-A93(M)(L)(Z)	
M9//	—	Without auto switch (with built-in magnet)

Note 1) Auto switches shown above cannot be mounted on the high temperature type. For the high temperature type, a semi-standard product that uses the heat resistant auto switch D-7FNJ* is available. For details, please contact SMC.

Note 2) Standard lead wire length is 0.5 m. Add "L" to the end of the part number when 3 m is desired, "M" when 1 m, and "Z" when 5 m.

Example) -M9NL

⑦ Body surface treatment/Seal material and its changed part

• Body surface treatment	
Symbol	Surface treatment
Nil	External: Hard anodized Internal: Raw material
A	External: Hard anodized Internal: Oxalic acid anodized

• Seal material

Symbol	Seal material	Compound No.
Nil	FKM	1349-80*
N1	EPDM	2101-80*
P1	Barrel Perfluoro®	70W
Q1	Kalrez®	4079
R1	Chemraz®	SS592
R2		SS630
R3		SSE38
S1	VMQ	1232-70*
T1	FKM for Plasma	3310-75*
U1	ULTIC ARMOR®	UA4640

* Produced by Mitsubishi Cable Industries, Ltd.

• Seal material changed part and leakage

Symbol	Changed part	Leakage (Pa·m ³ /s or less) Note 1)	
		Internal	External
Nil	None	1.3 x 10 ⁻¹⁰ (FKM)	1.3 x 10 ⁻¹⁰ (FKM)
A	②, ③	1.3 x 10 ⁻⁸	1.3 x 10 ⁻⁸
B	②	1.3 x 10 ⁻⁸	1.3 x 10 ⁻¹⁰ (FKM)
C	③	1.3 x 10 ⁻¹⁰ (FKM)	1.3 x 10 ⁻⁸

Note 1) Values at normal temperature, excluding gas permeation.

Note 2) Refer to parts number of "Construction" on page 438 for changed part.

Number indicates parts number of "Construction" accordingly.

Note 3) Part ③ (exterior seal) is not changeable for sizes 16 and 25.

To order something other than "Nil" (standard), list the symbols starting with "X," followed by each symbol for "body surface treatment," "seal material" and then "changed part".

Example) XLG-40-M9NA-XAN1A

Barrel Perfluoro® is a registered trademark of Matsumura Oil Co., Ltd. Kalrez® is a registered trademark of E. I. du Pont de Nemours and Company or its affiliates.

Chemraz® is a registered trademark of Greene, Tweed Technologies, Inc. ULTIC ARMOR® is a registered trademark of Nippon Valqua Industries, Ltd.

XLG/XLGV Series

Specifications

Model		XLG(V)-16	XLG(V)-25	XLG(V)-40	XLG-50	XLG-63	XLG-80	XLG-100	XLG-160
Valve type		Double acting (Dual operation), Pressurize to open/close							
Fluid		Inert gas under vacuum							
Operating temperature (°C)	XLG	5 to 60 (High temperature type: 5 to 150)							
	XLGV	5 to 50							
Operating pressure (Pa) (abs)		Atmospheric pressure to 1×10^{-5}							
Conductance (L/s) <small>Note 1)</small>		5	14	45	80	160	200	300	800
Leakage (Pa·m³/s)	Internal	In case of standard material FKM: 1.3×10^{-10} at normal temperature, excluding gas permeation							
	External	In case of standard material FKM: 1.3×10^{-10} at normal temperature, excluding gas permeation							
Flange type		KF (NW)				KF (NW), K (DN)			
Principal materials		Body: Aluminum alloy, Main part: Stainless steel, FKM (Standard seal material)							
Surface treatment		External: Hard anodized				Internal: Raw material			
Pilot pressure (MPa) (G)		0.3 to 0.6				0.4 to 0.6			
Pilot port size	XLG	M5				Rc1/8			
	XLGV	M5: Port 1(P), Port 3(R), Port 5(R)							
Weight (kg)	XLG	0.28	0.46	1.1	1.4	2.3	4.1	7.6	14.9
	XLGV	0.32	0.5	1.14	1.5	2.4	4.2	—	—

Note 1) Conductance is the value for an elbow with the same dimensions.

Note 2) For valve heater specifications, refer to "Common Option [1] Heater" on page 459.

Note 3) A coating of vacuum grease [Y-VAC2] is applied to the seal-material sliding portion of the vacuum part.

Construction/Operation

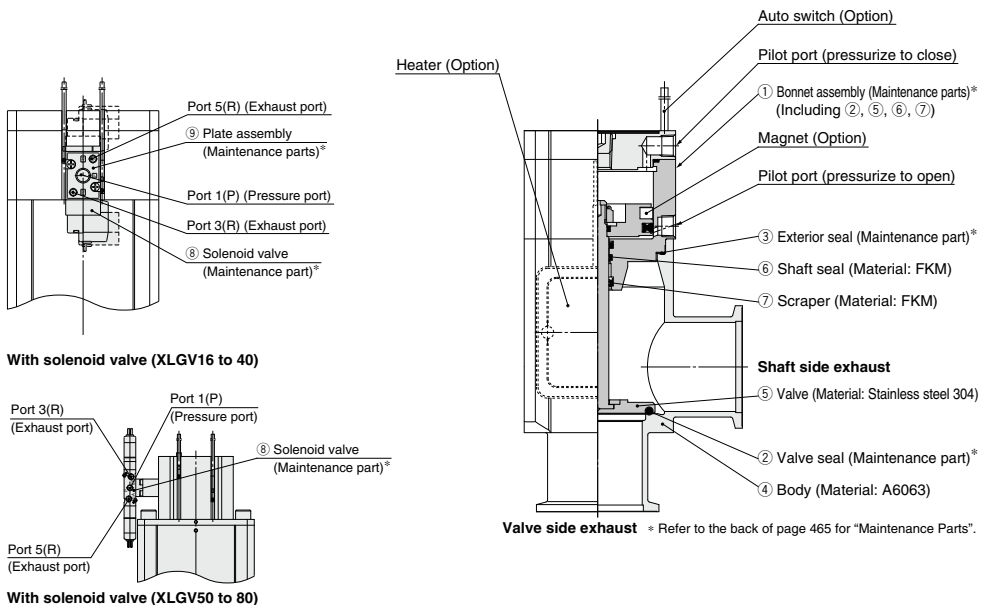

<Working principle>

By applying the pilot pressure from the pilot port P-1, the piston-coupled valve overcomes the operating force by pressure, and the valve opens. (Pilot port P-2 is open.) Conversely, by applying the pilot pressure to the pilot port P-2, the valve closes. (Pilot port P-1 is open.) For the XLGV, the pilot pressure is always applied to the port 1(P), and the valve opens when the solenoid valve is turned ON and closes when it is turned OFF. For the double solenoid, the valve moves to the opposite side from that in which the solenoid valve is turned ON.

<Options>

Auto switch: The magnet activates the auto switch. With 2 auto switches, the open and closed positions are detected, and with 1 auto switch, either the open or closed position is detected. Auto switches are applicable at ordinary temperatures only (5 to 60°C).

Heater: Simple heating is performed using thermistors. The valve body can be heated to approximately 100 or 120°C, depending on the heater option and the valve size. The type and number of thermistors to be used will vary depending upon size and setting temperature. In the case of high temperature specifications, the bonnet assembly is a heat resistant structure. This does not apply in cases where a solenoid valve is attached.

Dimensions

**XLG16, 25, 40/
Air operated**

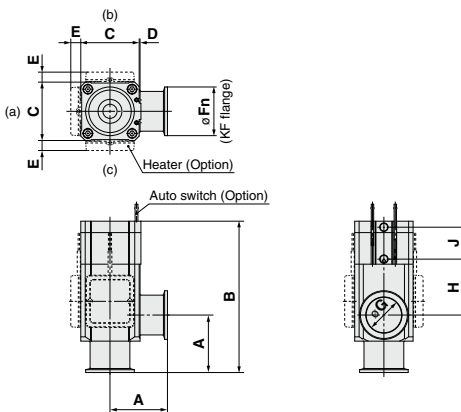

(mm)

Model	A	B	C	D	E (Note 1)	F _n	G	H	J
XLG-16	40	110	38	1	—	30	17	40	26
XLG-25	50	121	48	1	12	40	26	39	28
XLG-40	65	171	66	2	11	55	41	63	36

Note 1) Dimension E applies when heater option is included. (Lead wire length: approx. 1 m)
Note 2) (a), (b) and (c) in the above drawing indicate heater mounting positions.

Moreover, heater mounting positions will differ depending on the type of heater.
For further details, refer to mounting positions under "Replacement Heaters" on page 465.

**XLG50, 63, 80, 100, 160/
Air operated**

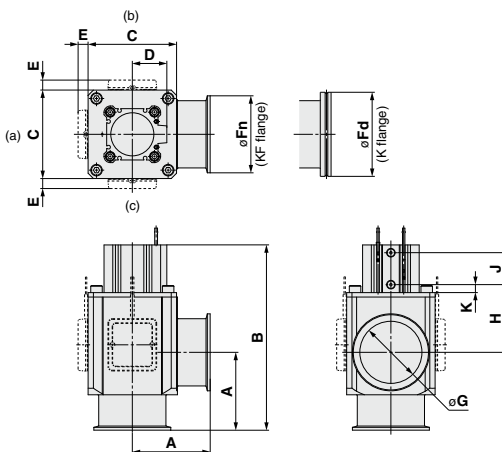

(mm)

Model	A	B	C	D	E (Note 1)	F _n	F _d	G	H	J	K
XLG-50	70	183	80	31	10.5	75	—	52	77	29	10.5
XLG-63	88	209	100	39	11	87	95	70	76.5	36	9
XLG-80	90	250	117	45.5	11	114	110	83	105	44	9
XLG-100	108	270.5	154	55	11	134	130	102	92	58	9
XLG-160	138	339	200	65	11	190	180	153	124	62	12.5

Note 1) Dimension E applies when heater option is included. (Lead wire length: approx. 1 m)
Note 2) (a), (b) and (c) in the above drawing indicate heater mounting positions.

Moreover, heater mounting positions will differ depending on the type of heater.
For further details, refer to mounting positions under "Replacement Heaters" on page 465.

XLA

XL□

XL□Q

XM□

XY□

D-□

XSA

XVD

XGT

CVV

XLG/XLGV Series

Dimensions

XLGV/With solenoid valve

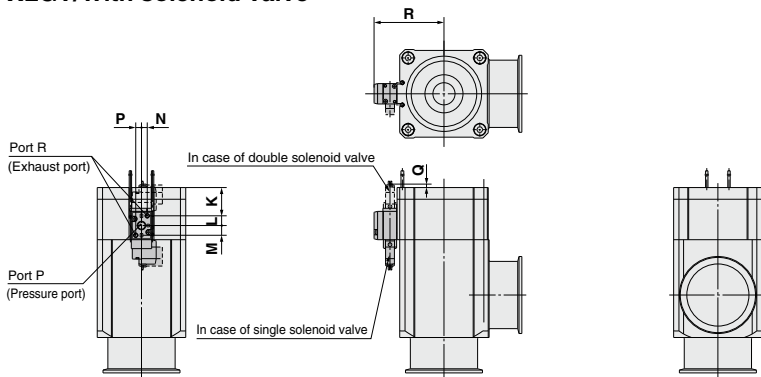

(mm)

Model	K	L	M	N	P	Q	R
XLGV-16	14.3	9.2	6.4	3.5	2.7	17.3	36
XLGV-25	15.8	9.2	6.4	3.5	2.7	15.8	41
XLGV-40	29	9.2	6.4	3.5	2.7	2.6	51

* Other dimensions are the same as the XLG.
 (Note) For details, consult your SMC sales representative.

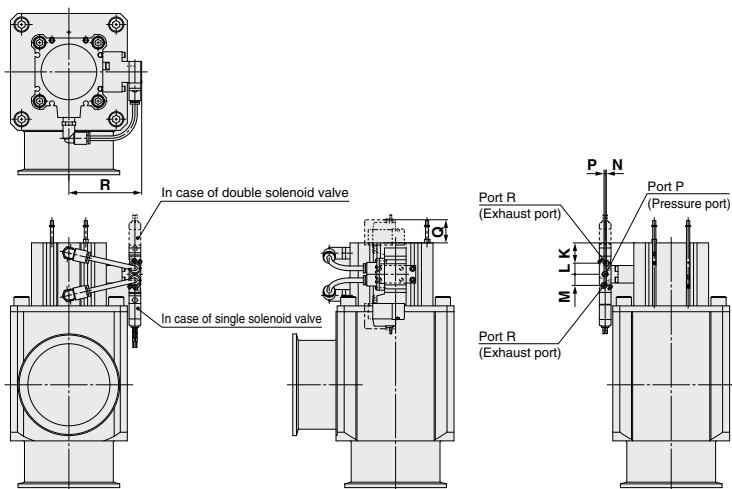

(mm)

Model	K	L	M	N	P	Q	R
XLGV-50	12.5	9.5	9.5	1	1	23.5	52.6
XLGV-63	17.4	9.5	9.5	1	1	18.6	62.3
XLGV-80	23.5	9.5	9.5	1	1	12.4	70.8

* Other dimensions are the same as the XLG.
 (Note) For details, consult your SMC sales representative.

XLA
XL □
XL□Q
XM□ XY□
D-□
XSA
XVD
XGT
CYV

How to Order Valve

XLGR-80 - **1** - **1K** - **X**

Flange type

Symbol	Type
NII	KF (NW)
D	K (DN)

Main valve: Pilot port direction

Symbol	Pilot port direction
NII	Flange side
K	Left flange surface
L	Rear flange surface
M	Right flange surface

* Flange: (A)

Temperature specifications

Symbol	Temperature	Heater
NII	5 to 60°C	—
HO	5 to 150°C	—

Seal material

Symbol	Seal material	Compound No.
NII	FKM	1349-80
N1	EPDM	2101-80
P1	Barrel Perfluoro®	70W
Q1	Kalrez®	4079
R1	Chemraz®	SS592
R2		SS630
R3		SSE38
S1	VMO	1232-70
T1	FKM FOR PLASMA	3310-75
U1	ULTIC ARMOR®	UA4640

Barrel Perfluoro® is a registered trademark of Matsumura Oil Co., Ltd.
 Kalrez® is a registered trademark of E. I. du Pont de Nemours and Company or its affiliates.
 Chemraz® is a registered trademark of Greene, Tweed Technologies, Inc.
 ULTIC ARMOR® is a registered trademark of Nippon Valqua Industries, Ltd.

Auto switch type (Operating temperature 5 to 60°C)

Symbol	Auto switch model	Switch type
NII	—	Without auto switch (without built-in magnet)
M9N(M)(L)(Z)	D-M9N(M)(L)(Z)	Solid state auto switch
M9P(M)(L)(Z)	D-M9P(M)(L)(Z)	
M9B(M)(L)(Z)	D-M9B(M)(L)(Z)	
A90(L)	D-A90(L)	Reed auto switch
A93(M)(L)(Z)	D-A93(M)(L)(Z)	Without auto switch (with built-in magnet)
M9/	—	

Note 1) Types with auto switches are not available in case of high temperature types.
 Standard lead wire length is 0.5 m. Add "L" to the end of the part number when 3 m is desired, "M" when 1 m, and "Z" when 5 m.
 Note 2) A type with a pre-wired connector is also selectable. Example) -M9NSAPC
 Note 3) Refer to the **Auto Switch** Catalog for further information on auto switches.

Bypass valve mounting position/ Pilot port direction

Symbol	Mounting position	Symbol	Pilot port direction
		S	Flange side
1	Left flange surface	K	Left flange surface
		L	Rear flange surface
		S	Flange side
2	Right flange surface	L	Rear flange surface
		M	Right flange surface
		K	Left flange surface
3	Rear flange surface	L	Rear flange surface
		M	Right flange surface
		K	Left flange surface

* Flange: (A)

When the seal material is not being changed, there is no need to select a symbol.

Seal material changed part

Symbol	Changed part	Leakage (Pa·m ³ /s or less) ^{Note)}	
		Internal	External
NII	None	1.3 x 10 ⁻⁹ (FKM)	1.3 x 10 ⁻⁹ (FKM)
A	(2-1)(7-1)(4)(7-2)(8)	1.3 x 10 ⁻⁷	1.3 x 10 ⁻⁷
B	(2-1)(7-1)	1.3 x 10 ⁻⁷	1.3 x 10 ⁻⁹ (FKM)
C	(4)(7-2)(8)	1.3 x 10 ⁻⁹ (FKM)	1.3 x 10 ⁻⁷

Note) Values at normal temperature, excluding gas permeation.

Number of auto switches/Mounting position

Symbol	Quantity	Mounting position
NII	—	Without auto switch
A	2 pcs.	Valve open/closed
B	1 pc.	Valve open
C	1 pc.	Valve closed

Maintenance Parts

② **Bonnet Assembly Part No.**

XLG80-30-1H-1 **M9NA-XN1**

Bonnet assembly

Temperature	Part no.
5 to 60°C	XLG80-30-1-1
5 to 150°C	XLG80-30-1H-1

Same as How to Order

Specifications

Valve type	Main valve: Double acting	Bypass valve: Normally closed
Shaft seal type	O-ring seal	Bellows seal
Operating pressure range	Atmospheric pressure to 1 x 10 ⁵ Pa	
Fluid	Inert gas under vacuum	
Operating temperature	5 to 60°C (Option: 5 to 150°C)	
Conductance	200 L/s*	Max. 25 L/s (Calculated value)
Operating pressure	0.4 to 0.6 MPa	
Flange	KF80, K80	
Weight	4.9 kg	

* Conductance is the value for the "molecular flow" of an elbow with the same dimensions.

⑧ **Bypass Valve Part No.**

XLG-16 - - **X65**

Pilot port direction

Symbol	Pilot port direction
NII	Rear (as seen from body connection point)
K	Left (as seen from body connection point)
M	Right (as seen from body connection point)

Seal material changed part

Symbol	Changed part
NII	None
A	(7-1) (7-2)
B	(7-1)
C	(7-2)

Temperature specifications

Symbol	Temperature
NII	5 to 60°C
HO	5 to 150°C

Seal material:
 Same as the seal materials of How to Order Valve

Aluminum High Vacuum Angle Valve/Double Acting/O-ring Seal XLG Series

Made to Order Specifications 2



Please contact SMC for detailed dimensions, specifications and lead times.

With Bypass Valve (Flange size: 100)

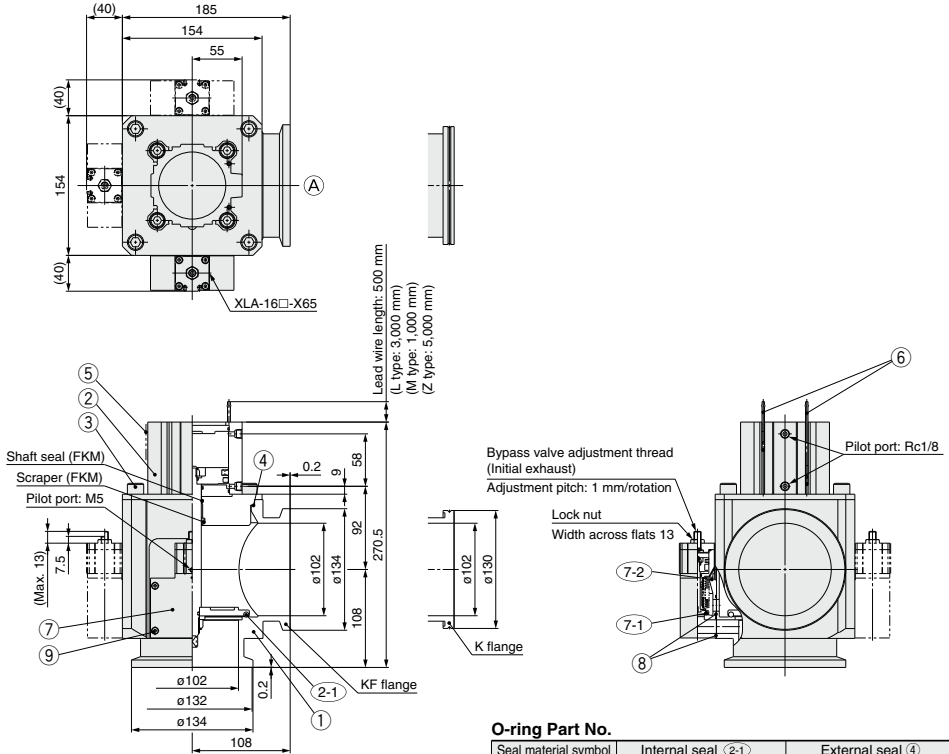

Symbol



Component Parts

No.	Description	Material	Remarks
1	Body	A6063	
2	Bonnet assembly		Refer to maintenance parts
2-1	O-ring		Refer to part no.
3	Hexagon socket head cap screw	SS	M12, L = 20
4	O-ring		Refer to part no.
5	Computer name plate		
6	Auto switch		Option
7	High vacuum angle valve (Bypass valve)		Refer to maintenance parts
7-1	O-ring		Refer to part no.
7-2	O-ring		Refer to part no.
8	O-ring		Refer to part no.
9	Hexagon socket head cap screw	Stainless steel	M4, L = 40

O-ring Part No.

Seal material symbol	Internal seal (2-1)	External seal (4)
NII	AS568-349V	AS568-050V
N1	AS568-349-XN1	AS568-050-XN1
P1	AS568-349-XP1	AS568-050-XP1
Q1	AS568-349-XQ1	AS568-050-XQ1
R1	AS568-349-XR1	AS568-050-XR1
R2	AS568-349-XR2	AS568-050-XR2
R3	AS568-349-XR3	AS568-050-XR3
S1	AS568-349-XS1	AS568-050-XS1
T1	AS568-349-XT1	AS568-050-XT1
U1	AS568-349-XU1	AS568-050-XU1

O-ring Part No.

Seal material symbol	Internal seal (7-1)	External seal (7-2)	External seal (8)
NII	B2401-V15V	AS568-025V	AS568-017V
N1	B2401-V15-XN1	AS568-025-XN1	AS568-017-XN1
P1	B2401-V15-XP1	AS568-025-XP1	AS568-017-XP1
Q1	B2401-V15-XQ1	AS568-025-XQ1	AS568-017-XQ1
R1	B2401-V15-XR1	AS568-025-XR1	AS568-017-XR1
R2	B2401-V15-XR2	AS568-025-XR2	AS568-017-XR2
R3	B2401-V15-XR3	AS568-025-XR3	AS568-017-XR3
S1	B2401-V15-XS1	AS568-025-XS1	AS568-017-XS1
T1	B2401-V15-XT1	AS568-025-XT1	AS568-017-XT1
U1	B2401-V15-XU1	AS568-025-XU1	AS568-017-XU1

Note) A coating of vacuum grease (fluorinated grease: Y-VAC2) is applied to the shaft seal, scraper and O-ring (8).

How to Order Valve

XLGR-100 - **1** - **1K-X**

Flange type

Symbol	Type
Nil	KF (NW)
D	K (DN)

Main valve: Pilot port direction

Symbol	Pilot port direction
Nil	Flange side
K	Left flange surface
L	Rear flange surface
M	Right flange surface

* Flange: (A)

Temperature specifications

Symbol	Temperature	Heater
Nil	5 to 60°C	—
HO	5 to 150°C	—

Auto switch type (Operating temperature 5 to 60°C)

Symbol	Auto switch model	Switch type
Nil	—	Without auto switch (without built-in magnet)
M9N(M)(L)(Z)	D-M9N(M)(L)(Z)	Solid state auto switch
M9P(M)(L)(Z)	D-M9P(M)(L)(Z)	
M9B(M)(L)(Z)	D-M9B(M)(L)(Z)	
A90(L)	D-A90(L)	Reed auto switch
A93(M)(L)(Z)	D-A93(M)(L)(Z)	
M9//	Without auto switch (with built-in magnet)	

Note 1) Types with auto switches are not available in case of high temperature types.

Standard lead wire length is 0.5 m. Add "L" to the end of the part number when 3 m is desired, "M" when 1 m, and "Z" when 5 m.

Note 2) A type with a pre-wired connector is also selectable. Example) -M9NSAPC

Note 3) Refer to the [Auto Switch Catalog](#) for further information on auto switches.

Number of auto switches/Mounting position

Symbol	Quantity	Mounting position
Nil	—	Without auto switch
A	2 pcs.	Valve open/closed
B	1 pc.	Valve open
C	1 pc.	Valve closed

**Bypass valve mounting position/
Pilot port direction**

Symbol	Mounting position	Symbol	Pilot port direction
1	Left flange surface	S	Flange side
		K	Left flange surface
		L	Rear flange surface
2	Right flange surface	S	Flange side
		L	Rear flange surface
		M	Right flange surface
3	Rear flange surface	K	Left flange surface
		L	Rear flange surface
		M	Right flange surface

* Flange: (A)

Seal material

Symbol	Seal material	Compound No.
Nil	FKM	1349-80
N1	EPDM	2101-80
P1	Barrel Perfluoro®	70W
Q1	Kalrez®	4079
R1	Chemraz®	SS592
R2		SS630
R3		SSE38
T1	VMQ	1232-70
S1	FKM FOR PLASMA	3310-75
U1	ULTIC ARMOR®	UA4640

Barrel Perfluoro® is a registered trademark of Matsumura Oil Co., Ltd.
Kalrez® is a registered trademark of E. I. du Pont de Nemours and Company or its affiliates.
Chemraz® is a registered trademark of Greene, Tweed Technologies, Inc.
ULTIC ARMOR® is a registered trademark of Nippon Valqua Industries, Ltd.

When the seal material is not being changed, there is no need to select a symbol.

Seal material changed part

Symbol	Changed part	Leakage (Pa·m ³ /s or less) ^{Note)}	
		Internal	External
Nil	None	1.3 x 10 ⁻⁹ (FKM)	1.3 x 10 ⁻⁹ (FKM)
A	(2-1) (7-1) (4) (7-2) (8)	1.3 x 10 ⁻⁷	1.3 x 10 ⁻⁷
B	(2-1) (7-1)	1.3 x 10 ⁻⁷	1.3 x 10 ⁻⁹ (FKM)
C	(4) (7-2) (8)	1.3 x 10 ⁻⁹ (FKM)	1.3 x 10 ⁻⁷

Note) Values at normal temperature, excluding gas permeation.

Maintenance Parts

② **Bonnet Assembly Part No.**

XLG100-30-1H-1 **M9NA-XN1**

Bonnet assembly

Temperature	Part no.
5 to 60°C	XLG100-30-1-1
5 to 150°C	XLG100-30-1H-1

⑧ **Bypass Valve Part No.**

XLA-16 - - **X65**

Pilot port direction

Symbol	Pilot port direction
Nil	Rear (as seen from body connection point)
K	Left (as seen from body connection point)
M	Right (as seen from body connection point)

Seal material changed part

Symbol	Changed part
Nil	None
A	(7-1) (7-2)
B	(7-1)
C	(7-2)

Same as How to Order

Specifications

Valve type	Main valve: Double acting	Bypass valve: Normally closed
Shaft seal type	O-ring seal	Bellows seal
Operating pressure range	Atmospheric pressure to 1 x 10 ⁻⁵ Pa	
Fluid	Inert gas under vacuum	
Operating temperature	5 to 60°C (Option: 5 to 150°C)	
Conductance	300 L/s*	[Max. 31.5 L/s (Calculated value)]
Operating pressure	0.4 to 0.6 MPa	
Flange	KF100, K100	
Weight	8.3 kg	

* Conductance is the value for the "molecular flow" of an elbow with the same dimensions.

Temperature specifications

Symbol	Temperature
Nil	5 to 60°C
HO	5 to 150°C

Seal material: Same as the seal materials of How to Order Valve

How to Order Valve

XLGR-160 - 1 - 1K - X

Flange type

Symbol	Type
Nil	KF (NW)
D	K (DN)

Main valve: Pilot port direction

Symbol	Pilot port direction
Nil	Flange side
K	Left flange surface
L	Rear flange surface
M	Right flange surface

* Flange: (A)

Temperature specifications

Symbol	Temperature	Heater
Nil	5 to 60°C	—
HO	5 to 150°C	—

Seal material

Symbol	Seal material	Compound No.
Nil	FKM	1349-80
N1	EPDM	2101-80
P1	Barrel Perfluoro®	70W
Q1	Kalrez®	4079
R1	Chemraz®	SS592
R2		SS630
R3		SSE38
S1	VMO	1232-70
T1	FKM FOR PLASMA	3310-75
U1	ULTIC ARMOR®	UA4640

Barrel Perfluoro® is a registered trademark of Matsumura Oil Co., Ltd.
 Kalrez® is a registered trademark of E. I. du Pont de Nemours and Company or its affiliates.
 Chemraz® is a registered trademark of Greene, Tweed Technologies, Inc.
 ULTIC ARMOR® is a registered trademark of Nippon Valqua Industries, Ltd.

Auto switch type (Operating temperature 5 to 60°C)

Symbol	Auto switch model	Switch type
Nil	—	Without auto switch (without built-in magnet)
M9N(M)(L)(Z)	D-M9N(M)(L)(Z)	Solid state auto switch
M9P(M)(L)(Z)	D-M9P(M)(L)(Z)	
M9B(M)(L)(Z)	D-M9B(M)(L)(Z)	
A90(L)	D-A90(L)	Reed auto switch
A93(M)(L)(Z)	D-A93(M)(L)(Z)	
M9//	—	Without auto switch (with built-in magnet)

Note 1) Types with auto switches are not available in case of high temperature types.

Standard lead wire length is 0.5 m. Add "L" to the end of the part number when 3 m is desired, "M" when 1 m, and "Z" when 5 m.

Note 2) A type with a pre-wired connector is also selectable.

Example) -M9NSAPC

Note 3) Refer to the **Auto Switch Catalog** for further information on auto switches.

Number of auto switches/Mounting position

Symbol	Quantity	Mounting position
Nil	—	Without auto switch
A	2 pcs.	Valve open/closed
B	1 pc.	Valve open
C	1 pc.	Valve closed

**Bypass valve mounting position/
Pilot port direction**

Symbol	Mounting position	Symbol	Pilot port direction	
			S	Flange side
1	Left flange surface	K	Left flange surface	
		L	Rear flange surface	
		S	Flange side	
2	Right flange surface	L	Rear flange surface	
		M	Right flange surface	
		K	Left flange surface	
3	Rear flange surface	L	Rear flange surface	
		M	Right flange surface	
		K	Left flange surface	

* Flange: (A)

When the seal material is not being changed, there is no need to select a symbol.

Seal material changed part

Symbol	Changed part	Leakage (Pa·m ³ /s or less) ^{Note)}	
		Internal	External
Nil	None	1.3 x 10 ⁻⁹ (FKM)	1.3 x 10 ⁻⁹ (FKM)
A	(2-1) (7-1) (4) (7-2) (8)	1.3 x 10 ⁻⁷	1.3 x 10 ⁻⁷
B	(2-1) (7-1)	1.3 x 10 ⁻⁷	1.3 x 10 ⁻⁹ (FKM)
C	(4) (7-2) (8)	1.3 x 10 ⁻⁹ (FKM)	1.3 x 10 ⁻⁷

Note) Values at normal temperature, excluding gas permeation.

Maintenance Parts

② **Bonnet Assembly Part No.**

XLG160-30-1H-1 **M9NA-XN1**

Bonnet assembly

Temperature	Part no.
5 to 60°C	XLG160-30-1-1
5 to 150°C	XLG160-30-1H-1

⑧ **Bypass Valve Part No.**

XLA-16 - - **X65**

Pilot port direction

Symbol	Pilot port direction
Nil	Rear (as seen from body connection point)
K	Left (as seen from body connection point)
M	Right (as seen from body connection point)

Seal material changed part

Symbol	Changed part
Nil	None
A	(7-1) (7-2)
B	(7-1)
C	(7-2)

Specifications

Same as How to Order

Valve type	Main valve: Double acting	Bypass valve: Normally closed
Shaft seal type	O-ring seal	Bellows seal
Operating pressure range	Atmospheric pressure to 1 x 10 ⁻⁵ Pa	
Fluid	Inert gas under vacuum	
Operating temperature	5 to 60°C (Option: 5 to 150°C)	
Conductance	800 L/s*	Max. 31.5 L/s (Calculated value)
Operating pressure	0.4 to 0.6 MPa	
Flange	KF160, K160	
Weight	15.7 kg	

* Conductance is the value for the "molecular flow" of an elbow with the same dimensions.

Temperature specifications

Symbol	Temperature
Nil	5 to 60°C
HO	5 to 150°C

Seal material:
Same as the seal materials of How to Order Valve

Aluminum High Vacuum Angle Valve

2-Step Control, Single Acting/Bellows Seal, O-ring Seal

XLD/XLDV Series RoHS



XLD

How to Order

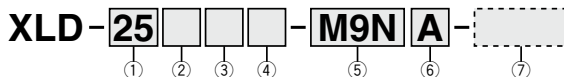

① Flange size

Size
25
40
50
63
80
100
160

② Flange type

Symbol	Type	Applicable flange
NII	KF (NW)	25, 40, 50, 63, 80 100, 160
D	K (DN)	63, 80, 100, 160

③ Pilot port direction

Symbol	Pilot port direction
NII	Flange side
K	Left flange surface
L	Rear flange surface
M	Right flange surface

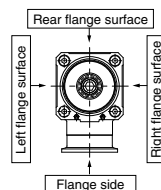

④ Temperature specifications/Heater

Symbol	Temperature	Heater
NII	5 to 60°C	—
High temperature type	H0	—
	H4	With 100°C heater
	H5	With 120°C heater

Note) Size 25 is not applicable for H4.

⑥ Number of auto switches/Mounting position

Symbol	Quantity	Mounting position
NII	Without auto switch	—
A	2 pcs.	Valve open/closed
B	1 pc.	Valve open
C	1 pc.	Valve closed

⑤ Auto switch type

Symbol	Auto switch model	Remarks
NII	—	Without auto switch (without built-in magnet)
M9N(M)(L)(Z)	D-M9N(M)(L)(Z)	Solid state auto switch
M9P(M)(L)(Z)	D-M9P(M)(L)(Z)	
M9B(M)(L)(Z)	D-M9B(M)(L)(Z)	
A90(L)	D-A90(L)	Reed auto switch
A93(M)(L)(Z)	D-A93(M)(L)(Z)	
M9//	—	Without auto switch (with built-in magnet)

Note 1) Auto switches shown above cannot be mounted on the high temperature type. For the high temperature type, a semi-standard product that uses the heat resistant auto switch D-F7NJ* is available. For details, please contact SMC.

Note 2) Standard lead wire length is 0.5 m. Add "L" to the end of the part number when 3 m is desired, "M" when 1 m, and "Z" when 5 m.

Example) -M9NL

Note 3) A type with a pre-wired connector is also selectable. Example) -M9NSAPC

Note 4) Refer to the [Auto Switch Catalog](#) for further information on auto switches.

⑦ Body surface treatment/Seal material and its changed part

• Body surface treatment

Symbol	Surface treatment
NII	External: Hard anodized Internal: Raw material
A	External: Hard anodized Internal: Oxalic acid anodized

• Seal material

Symbol	Seal material	Compound No.
NII	FKM	1349-80*
N1	EPDM	2101-80*
P1	Barrel Perfluoro®	70W
Q1	Chemraz®	Kalrez®
R1		SS592
R2		SS630
R3		SSE38
S1	VMQ	1232-70*
T1	FKM for Plasma	3310-75*
U1	ULTIC ARMOR®	UA4640

* Produced by Mitsubishi Cable Industries, Ltd.

• Seal material changed part and leakage

Symbol	Changed part ^{Note 2)}	Leakage (Pa·m ³ /s or less) ^{Note 1)}	
		Internal	External
NII	None	1.3 x 10 ⁻¹⁰ (FKM)	1.3 x 10 ⁻¹¹ (FKM)
A	②, ③, ④, ⑤	1.3 x 10 ⁻⁸	1.3 x 10 ⁻⁹
B	②, ④, ⑤	1.3 x 10 ⁻⁸	1.3 x 10 ⁻¹¹ (FKM)
C	③	1.3 x 10 ⁻¹⁰ (FKM)	1.3 x 10 ⁻⁹

Note 1) Values at normal temperature, excluding gas permeation.

Note 2) Refer to parts number of "Construction" on page 451 for changed part. Number indicates parts number of "Construction" accordingly.

To order something other than "NII" (standard), list the symbols starting with "X," followed by each symbol for "body surface treatment," "seal material" and then "changed part".

Example) XLD-25-M9NA-XANIAI

Barrel Perfluoro® is a registered trademark of Matsumura Oil Co., Ltd. Kalrez® is a registered trademark of E. I. du Pont de Nemours and Company or its affiliates.

Chemraz® is a registered trademark of Greene, Tweed Technologies, Inc. ULTIC ARMOR® is a registered trademark of Nippon Valqua Industries, Ltd.

Air Operated/with Solenoid Valve



How to Order

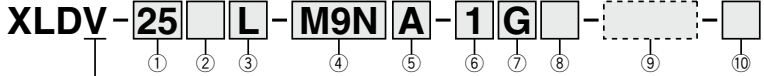

• Air operated/with solenoid valve

① Flange size

Size
25
40
50
63
80
100
160

② Flange type

Symbol	Type	Applicable flange
Nii	KF (NW)	25, 40, 50, 63, 80, 100, 160
D	K (DN)	63, 80, 100, 160

③ Solenoid valve direction

Symbol	Solenoid valve direction
K	Left flange surface
L	Rear flange surface
M	Right flange surface

* M type is not available for size 25.

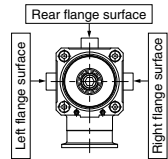

④ Auto switch type

Symbol	Auto switch model	Remarks
Nii	—	Without auto switch (without built-in magnet)
M9N(M)(L)(Z)	D-M9N(M)(L)(Z)	Solid state auto switch
M9P(M)(L)(Z)	D-M9P(M)(L)(Z)	
M9B(M)(L)(Z)	D-M9B(M)(L)(Z)	
A90(L)	D-A90(L)	Reed auto switch
A93(M)(L)(Z)	D-A93(M)(L)(Z)	
M9//	—	Without auto switch (with built-in magnet)

Note 1) Standard lead wire length is 0.5 m. Add "L" to the end of the part number when 3 m is desired, "M" when 1 m, and "Z" when 5 m. Example) -M9NL
 Note 2) A type with a pre-wired connector is also selectable. Example) -M9NSAPC
 Note 3) Refer to the [Auto Switch Catalog](#) for further information on auto switches.

⑤ Number of auto switches/Mounting position

Symbol	Quantity	Mounting position
Nii	Without auto switch	—
A	2 pcs.	Valve open/closed
B	1 pc.	Valve open
C	1 pc.	Valve closed

⑥ Rated voltage

		CE-compliant
1	100 VAC, 50/60 Hz	—
2	200 VAC, 50/60 Hz	—
3	110 VAC, 50/60 Hz	—
4	220 VAC, 50/60 Hz	—
5	24 VDC	○
6	12 VDC	○

⑦ Electrical entry

G	H	L	M
Grommet (Lead wire length 300 mm)	Grommet (Lead wire length 600 mm)	L type plug connector	M type plug connector

⑧ Light/Surge voltage suppressor

Symbol	
Nii	None
S	With surge voltage suppressor
Z	With light/surge voltage suppressor
U	With light/surge voltage suppressor (Non-polar type)

* S type: Not available for AC.
 * U type: DC only.

⑩ CE-compliant

Symbol	
Nii	—
Q	CE-compliant

⑨ Body surface treatment/Seal material and its changed part

• Body surface treatment

Symbol	Surface treatment
Nii	External: Hard anodized Internal: Raw material
A	External: Hard anodized Internal: Oxalic acid anodized

• Seal material

Symbol	Seal material	Compound No.
Nii	FKM	1349-80*
N1	EPDM	2101-80*
P1	Barrel Perfluoro®	70W
Q1	Kalrez®	4079
R1	Chemraz®	SS592
R2		SS630
R3		SSE38
S1	VMQ	1232-70*
T1	FKM for Plasma	3310-75*
U1	ULTIC ARMOR®	UA4640

* Produced by Mitsubishi Cable Industries, Ltd.

Barrel Perfluoro® is a registered trademark of Matsumura Oil Co., Ltd.
 Kalrez® is a registered trademark of E. I. du Pont de Nemours and Company or its affiliates.
 Chemraz® is a registered trademark of Greene, Tweed Technologies, Inc.
 ULTIC ARMOR® is a registered trademark of Nippon Valqua Industries, Ltd.

• Seal material changed part and leakage

Symbol	Changed part	Leakage (Pa·m ³ /s or less) Note 1)	
		Internal	External
Nii	None	1.3 x 10 ⁻¹⁰ (FKM)	1.3 x 10 ⁻¹¹ (FKM)
A	②, ③, ④, ⑤	1.3 x 10 ⁻⁸	1.3 x 10 ⁻⁹
B	②, ④, ⑤	1.3 x 10 ⁻⁸	1.3 x 10 ⁻¹¹ (FKM)
C	③	1.3 x 10 ⁻¹⁰ (FKM)	1.3 x 10 ⁻⁹

Note 1) Values at normal temperature, excluding gas permeation.

Note 2) Refer to parts number of "Construction" on page 451 for changed part. Number indicates parts number of "Construction" accordingly.

To order something other than "Nii" (standard), list the symbols starting with "X," followed by each symbol for "body surface treatment," "seal material" and then "changed part".

Example) XLDV-25-M9NA-1G-XAN1A

Note 1) Option specifications/Combinations

This model has auto switch and K(DN) flange options, but high temperature/heater options are not available.

Note 2) Solenoid valves

Model	Initial exhaust valve	Main exhaust valve	Example
XLDV-25	V114	V114	V114-1GS
XLDV-40/50/63/80/100/160		SYJ314	SYJ314-1GS

* For details, consult your SMC sales representative.

* For option "Q", the solenoid valve should be a CE-compliant product.

XLD/XLDV Series

Specifications

Model		XLD(V)-25	XLD(V)-40	XLD(V)-50	XLD(V)-63	XLD(V)-80	XLD(V)-100	XLD(V)-160	
Valve type		Normally closed (Spring Return and seal) [Both main & initial exhaust valves]							
Fluid		Inert gas under vacuum							
Operating temperature (°C)	XLD	5 to 60 (High temperature type: 5 to 150)							
	XLDV	5 to 50							
Operating pressure (Pa) (abs)		1 x 10 ⁻⁶ to atmospheric pressure							
Conductance (L/s) <small>Note 1)</small>	Main exhaust valve	14	45	80	160	200	300	800	
	Initial exhaust valve	0.5 to 3	2 to 8	2.5 to 11	4 to 18	4 to 18	6.5 to 31.5	6.5 to 31.5	
Leakage (Pa·m³/s)	Internal	In case of standard material FKM: 1.3 x 10 ⁻¹⁰ at normal temperature, excluding gas permeation							
	External	In case of standard material FKM: 1.3 x 10 ⁻¹¹ at normal temperature, excluding gas permeation							
Flange type		KF (NW)				KF (NW), K (DN)			
Principal materials <small>Note 3)</small>		Body: Aluminum alloy, Bellows: Stainless steel 316L, Main part: Stainless steel, FKM (Standard seal material)							
Surface treatment		External: Hard anodized Internal: Raw material							
Pilot pressure (MPa) (G)		0.4 to 0.7 [Both main & initial exhaust valves]							
Pilot port size	XLD	M5	Rc1/8					Rc1/4	
	XLDV	M5: Port 1(P), Port 3(R)							
Weight (kg)	XLD	0.5	1.2	1.8	3.4	5.6	11.5	20	
	XLDV	0.57	1.3	1.9	3.5	5.7	11.6	20.1	

Note 1) The main exhaust valve conductance is the valve for the "molecular flow" of an elbow with the same dimensions. The initial exhaust valve conductance is the value for the "viscous flow".

Note 2) For valve heater specifications, refer to "Common Option [1] Heater" on page 459.

Note 3) A coating of vacuum grease [Y-VAC2] is applied to the seal-material sliding portion (initial exhaust valves sliding parts) of the vacuum part.

Construction/Operation

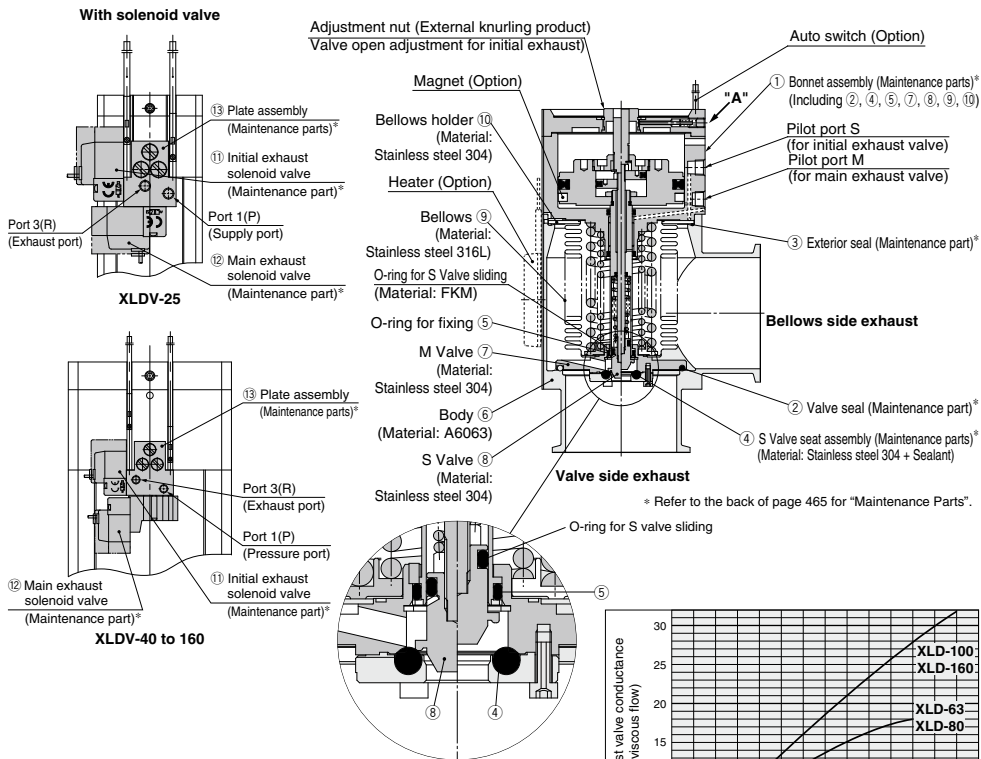

<Working principle>

- 1 Initial exhaust valve opening adjustment**
The initial exhaust rate should be adjusted without applying the pilot pressure to the pilot port S before operation. The initial exhaust rate is set to zero by gently turning the adjustment nut clockwise until it stops. (Do not use any tools.) The initial exhaust rate is adjusted by turning the adjustment nut counter-clockwise.
- 2 Opening of the initial exhaust valve (valve S)**
When the pilot pressure is applied to the pilot port S, the valve S is removed from the valve S seal assembly, and the valve opens the adjusted amount. For the XLDV, when the pilot pressure is always applied to the port 1(P) and the initial exhaust solenoid valve is turned ON, the valve opens the adjusted amount.
- 3 Opening of the main exhaust valve (valve M)**
When the pilot pressure is applied to the pilot port M, the valve M is removed from the body seat portion, and the valve fully opens. For the XLDV, when the pilot pressure is applied to the port 1(P) and the initial exhaust solenoid valve is turned ON, the valve fully opens.
- 4 Closing of the initial exhaust / main exhaust valves**
By removing the pilot pressure from the pilot port S and pilot port M, both S and M valves return to their previous positions and they are sealed. For the XLDV, by turning OFF the initial exhaust valve and main exhaust valve, both S and M valves return to their previous positions and they are sealed.



<Options>

- Auto switch:** The magnet actuates the auto switch. With two auto switches, the open and closed positions are detected, and with one auto switch, either the open or closed position is detected. Auto switches are applicable at ordinary temperatures only (5 to 60°C).
- Heater:** Simple heating is performed using thermistors. The valve body can be heated to approximately 100 or 120°C, depending on the heater option and valve size. The type and number of thermistors to be used will vary depending upon size and setting temperature. In the case of high temperature specifications, the bonnet assembly is a heat resistant structure. This is not available with solenoid valve.

Note) The adjustment nut does not rotate during valve operation. However, rotation of the adjustment nut can be fixed to prevent incorrect operation. When fixing the adjustment nut after setting, tighten it with the tightening torque shown in the table below. (Tightening with excessive torque can result in damaged components or the generation of abnormal noise.)

"A" Section Thread Tightening Torque

Model	XLD(V)-25	XLD(V)-40	XLD(V)-50	XLD(V)-63	XLD(V)-80	XLD(V)-100	XLD(V)-160
Tightening torque	0.08 N·m (0.8 kgf·cm) or less				0.3 N·m (3 kgf·cm) or less		

- XLA
- XL□
- XL□Q
- XM□
- XY□
- D-□
- XSA
- XVD
- XGT
- CVV

XLD/XLDV Series

Dimensions

XLD/Air operated

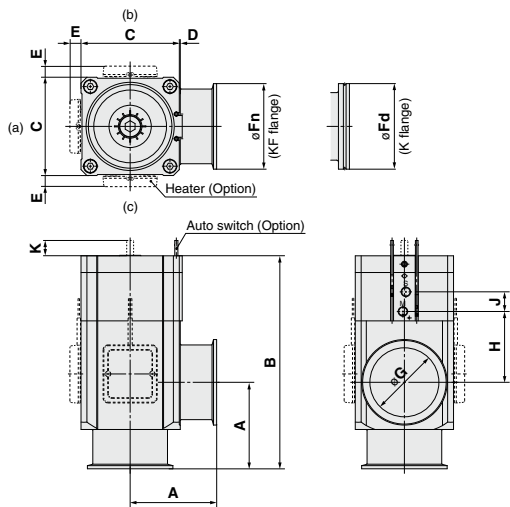

(mm)

Model	A	B	C	D	E	F _n	F _d	G	H	J	K
XLD-25	50	123	48	1	12	40	—	26	41	16	7.5
XLD-40	65	170	66	2	11	55	—	41	63	20	15
XLD-50	70	183	79	2	11	75	—	52	68	20	17.5
XLD-63	88	217	100	3	11	87	95	70	72	20	20
XLD-80	90	256	117	3	11	114	110	83	98	20	26.5
XLD-100	108	321	154	3	11	134	130	102	133	20	38
XLD-160	138	335	200	3	11	190	180	153	114	30	40

Note 1) Dimension E applies when heater option is included. (Lead wire length: approx. 1 m)

Note 2) (a), (b) and (c) in the above drawing indicate heater mounting positions.

Moreover, heater mounting positions will differ depending on the type of heater.

For further details, refer to mounting positions under "Replacement Heaters" on page 465.

Dimensions

XLDV-25/With solenoid valve

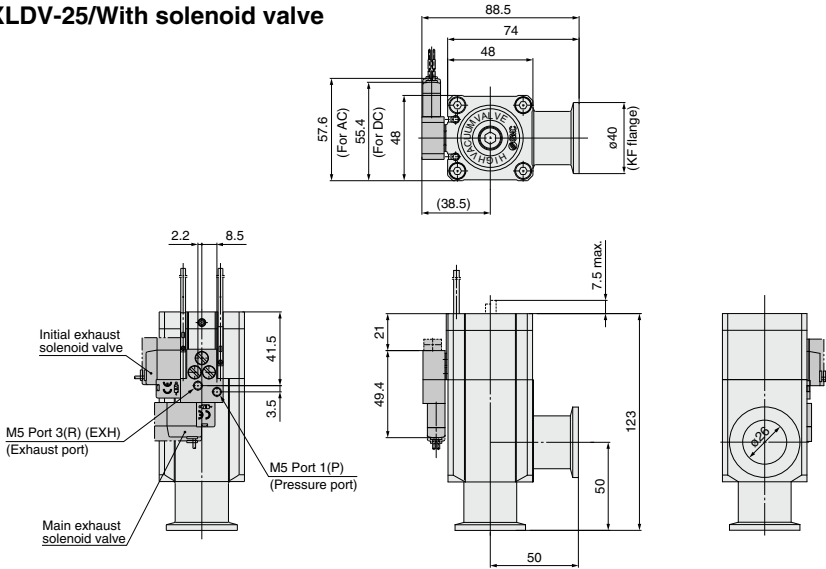

XLDV-40 to 160/With solenoid valve

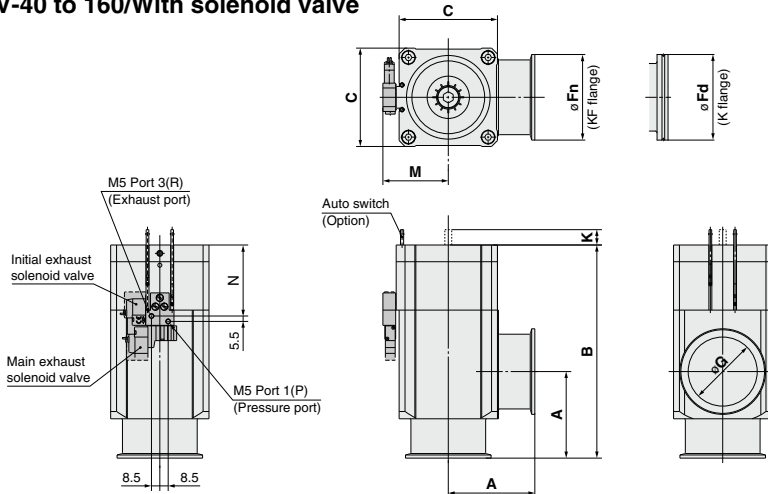

- XLA**
- XL**
- XL** Q
- XM**
- XY**
- D**
- XSA**
- XVD**
- XGT**
- CYV**

	(mm)									
Model	A	B	C	F _n	F _d	G	M	N	K	
XLDV-40	65	170	66	55	—	41	48.5	53.5	15	
XLDV-50	70	183	79	75	—	52	55	57.5	17.5	
XLDV-63	88	217	100	87	95	70	66.5	72.2	20	
XLDV-80	90	256	117	114	110	83	75	82.6	26.5	
XLDV-100	108	321	154	134	130	102	93.5	95.2	38	
XLDV-160	138	335	200	190	180	153	116.5	101.2	40	

Note) For details, consult your SMC sales representative.

Aluminum High Vacuum Angle Valve Manual/Bellows Seal **XLH Series**

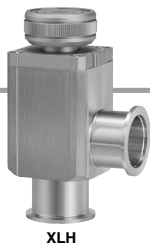

How to Order

XLH - 16 -

High vacuum
manual angle valve
(Bellows seal)

① Flange size

Size
16
25
40
50

② Heater

Symbol	Heater	Applicable flange size			
		16	25	40	50
Nil	—	●	●	●	●
H4	With 100°C heater	—	—	●	●
H5	With 120°C heater	—	—	●	●

Note) Size 16 is not applicable for H4, H5, Size 25 not for H4.

③ Body surface treatment/Seal material and its changed part

• Body surface treatment

Symbol	Surface treatment
Nil	External: Hard anodized Internal: Raw material
A	External: Hard anodized Internal: Oxalic acid anodized

• Seal material

Symbol	Seal material	Compound No.
Nil	FKM	1349-80*
N1	EPDM	2101-80*
P1	Barrel Perfluoro®	70W
Q1	Kalrez®	4079
R1	Chemraz®	SS592
R2		SS630
R3		SSE38
S1	VMQ	1232-70*
T1	FKM for Plasma	3310-75*
U1	ULTIC ARMOR®	UA4640

* Produced by Mitsubishi Cable Industries, Ltd.

• Seal material changed part and leakage

Symbol	Changed part ^{Note 2)}	Leakage (Pa·m ³ /s or less) ^{Note 1)}	
		Internal	External
Nil	None	1.3 x 10 ⁻¹⁰ (FKM)	1.3 x 10 ⁻¹¹ (FKM)
A	②, ③	1.3 x 10 ⁻⁸	1.3 x 10 ⁻⁹
B	②	1.3 x 10 ⁻⁸	1.3 x 10 ⁻¹¹ (FKM)
C	③	1.3 x 10 ⁻¹⁰ (FKM)	1.3 x 10 ⁻⁹

Note 1) Values at normal temperature, excluding gas permeation.

Note 2) Refer to parts number of "Construction" on page 455 for changed part. Number indicates parts number of "Construction" accordingly.

To order something other than "Nil" (standard), list the symbols starting with "X", followed by each symbol for "body surface treatment", "seal material" and then "changed part".

Example) XLH-16-XAN1A

Barrel Perfluoro® is a registered trademark of Matsumura Oil Co., Ltd.
Kalrez® is a registered trademark of E. I. du Pont de Nemours and Company or its affiliates.
Chemraz® is a registered trademark of Greene, Tweed Technologies, Inc.
ULTIC ARMOR® is a registered trademark of Nippon Valqua Industries, Ltd.

Specifications

Model	XLH-16	XLH-25	XLH-40	XLH-50
Valve type	Inert gas under vacuum			
Fluid (°C)	5 to 150			
Operating pressure (Pa) (abs)	10 ⁻⁶ to atmospheric pressure			
Conductance (L/s) ^{Note 1)}	5	14	45	80
Leakage (Pa·m ³ /s)	Internal	In case of standard material FKM: 1.3 x 10 ⁻¹⁰ at normal temperature, excluding gas permeation		
	External	In case of standard material FKM: 1.3 x 10 ⁻¹¹ at normal temperature, excluding gas permeation		
Flange type	KF (NW)			
Principal materials	Body: Aluminum alloy, Bellows: Stainless steel 316L, Main part: Stainless steel, FKM (Standard seal material)			
Surface treatment	External: Hard anodized		Internal: Raw material	
Actuation torque (N·m)	0.1 ≤	0.15 ≤	0.35 ≤	0.5 ≤
Handle revolutions	5	7	10	13
Weight (kg)	0.23	0.41	1.05	1.62

Note 1) The conductance is the same as that of an elbow of the same dimensions.

Note 2) For valve heater specifications, refer to "Common Option [1] Heater" on page 459.

Construction/Operation

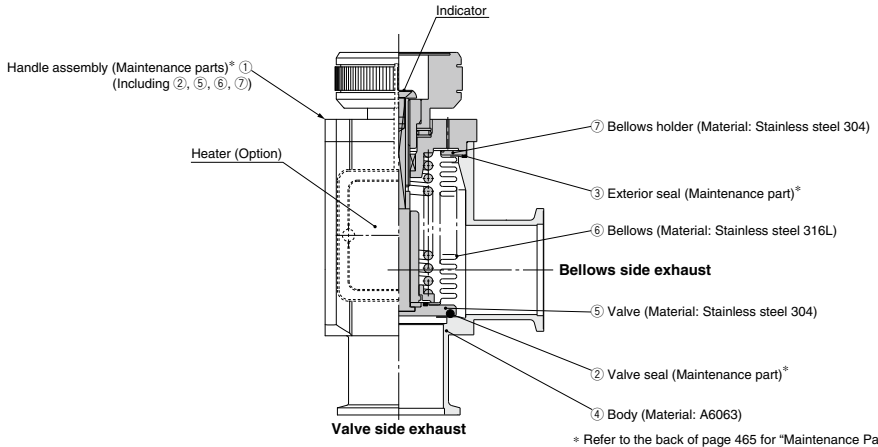

<Working principle>

By turning the handle to the left, the valve opens. The handle does not move up and down, but the indicator shows the open or closed position of the valve. As the handle is turned to the right, the valve closes, and when the turning force of the handle suddenly ceases to be felt, the valve is sealed. The sealing force for the valve comes from the spring, and is constant.

<Options>

Heater: Simple heating is performed using thermistors. The valve body can be heated to approximately 100 or 120°C, depending on the valve size.

The type and number of thermistors to be used will vary depending upon size and setting temperature.

Indicator: When the valve is open, an orange marker appears in the center of the name plate.

Dimensions

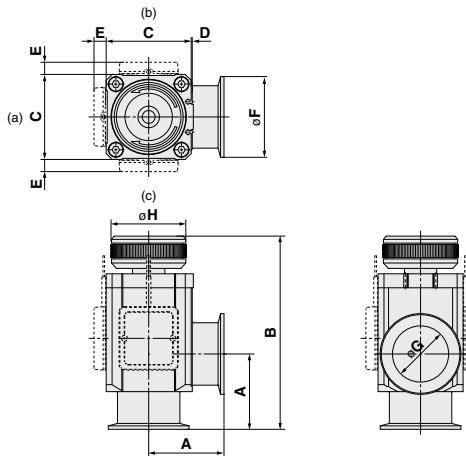

Model	A	B	C	D	E ^{Note 1)}	F	G	H
XLH-16	40	100.5	38	1	—	30	17	35
XLH-25	50	114	48	1	12	40	26	41
XLH-40	65	162.5	66	2	11	55	41	57
XLH-50	70	179.5	79	2	11	75	52	70

Note 1) Dimension E applies when heater option is included. (Lead wire length: approx. 1 m)

Note 2) (a), (b) and (c) in the above drawing indicate heater mounting positions.

Moreover, heater mounting positions will differ depending on the type of heater.

For further details, refer to mounting positions under "Replacement Heaters" on page 465.

Aluminum High Vacuum Angle Valve Electromagnetic/Bellows Pressure Balance

XLS Series



How to Order



Without control power supply

XLS — **25** — **5** **G** — □

With control power supply

XLS — **25** — **P** **1** **G**

High vacuum angle valve
(Bellows pressure balance,
2-stage voltage switching type)



Starting voltage

5	24 VDC
---	--------

Note 1) Holding voltage is 25% of starting voltage.

Note 2) For other rated voltages (48, 100 VDC), please consult with SMC.

Electrical entry

G	Grommet
C	Conduit
T	Terminal
D	DIN terminal

CE-compliant

Nil	—
Q (Note)	CE-compliant

Note) DIN terminal "D" only for 100 VDC

Valve size

16	KF16
25	KF25

Control power supply

P	With control power supply
----------	---------------------------

Note) There are no CE-compliant products with the control power supply.

Electrical entry

G	Grommet
----------	---------

Voltage

1	100 VAC
2	200 VAC
5	24 VDC

Warning

(1) In case there is no control power supply (XLS-25-□: 24/48/100 VDC), starting voltage should be applied for only 0.15 to 0.2 s, in accordance with the prescribed method (indicated on the back of the coil). Continuously applying starting voltage can cause overheating of the coil and fire. Holding voltage is 25% of the starting voltage (the application method is shown on the back of the solenoid coil).

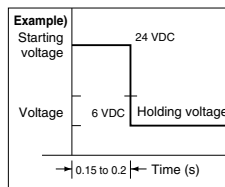

Specifications

Model		XLS-16	XLS-25	XLS-16-P□G	XLS-25-P□G
Valve type		Normally closed (N.C.)			
Fluid		Inert gas under vacuum			
Operating temperature (°C)		5 to 40			
Operating pressure (Pa)		0.1 MPa (G) to 1×10^{-6} (abs)			
Conductance (L/s) <small>Note 1)</small>		5	8	5	8
Leakage (Pa·m³/s)	Internal	1.3 × 10 ⁻⁸ at normal temperature, excluding gas permeation			
	External	1.3 × 10 ⁻¹¹ at normal temperature, excluding gas permeation			
Flange type/size		KF16	KF25	KF16	KF25
Principal materials <small>Note 2)</small>		Body: Aluminum alloy, Main part: Stainless steel, PFA, FKM (Standard seal material)			
Surface treatment		External: Hard anodized		Internal: Raw material	
Control power supply		No		Yes	
Operating power supply voltage		24/6, 48/12, 100/24 VDC		24 VDC, 100/200 VAC	
Allowable voltage fluctuation (%)				±10	
Electrical entry		G, C, D, T type		G type only	
Lead wire		AWG20, O.D.: 2.63 mm		VCTF2 x 0.75, O.D.: 2.3 mm, Sheath O.D.: 6.6 mm	
Coil insulation		Class B			
Maximum operating frequency (Hz)		0.17			
Weight (kg)		0.4	0.7	0.7	1.0

Note 1) Conductance is the value for an elbow with the same dimensions.

Note 2) A coating of vacuum grease [Y-VAC3] is applied to the valve seat of the vacuum part.

Power/Voltage

At the Rated Voltage

Model		Starting		Holding		
		Power (W)	Current (A)	Power (W)	Current (A)	
XLS-16-	□G/C/D/T, P5G	36	1.5	4.8	0.38	
	P1G	50 Hz	30.5	0.47	14.8	0.35
		60 Hz			10	0.27
	P2G	50 Hz	30	0.24	4.9	0.11
		60 Hz			2.3	0.10
	XLS-25-	□G/C/D/T, P5G	47	2.0	5.3	0.5
P1G		50 Hz	42	0.62	20	0.46
		60 Hz			13.5	0.36
P2G		50 Hz	45	0.35	6.7	0.15
		60 Hz			3.0	0.12

Construction/Operation

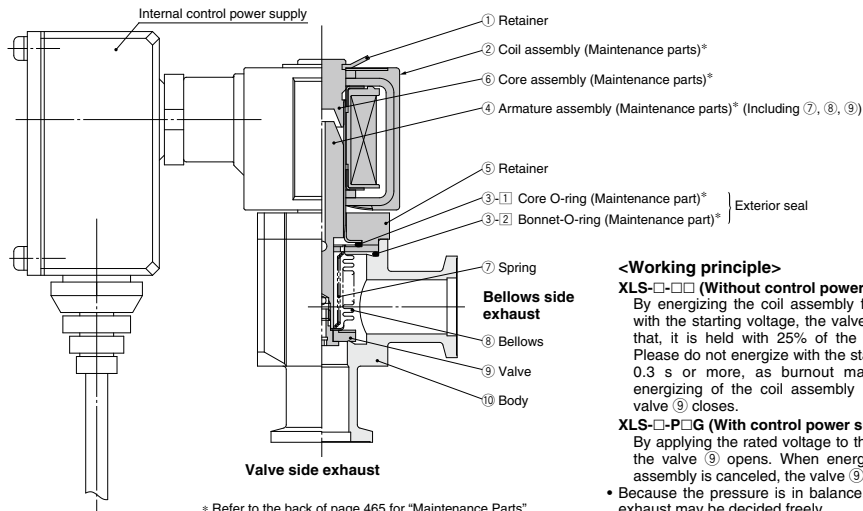

* Refer to the back of page 465 for "Maintenance Parts".

<Working principle>

XLS-□-□ (Without control power supply)

By energizing the coil assembly for 0.15 to 0.2 s with the starting voltage, the valve ⑨ opens. After that, it is held with 25% of the starting voltage. Please do not energize with the starting voltage for 0.3 s or more, as burnout may result. When energizing of the coil assembly is canceled, the valve ⑨ closes.

XLS-□-P□G (With control power supply)

By applying the rated voltage to the coil assembly, the valve ⑨ opens. When energizing of the coil assembly is canceled, the valve ⑨ closes.

- Because the pressure is in balance, the direction of exhaust may be decided freely.

XLA

XL□

XL□Q

XM□

XY□

D-□

XSA

XVD

XGT

CVV

XLS Series

Dimensions

XLS/Without control power supply

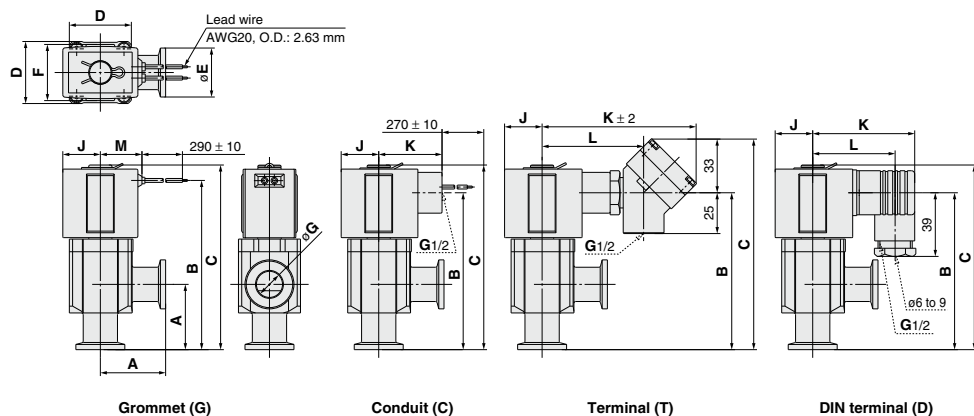

XLS/With control power supply

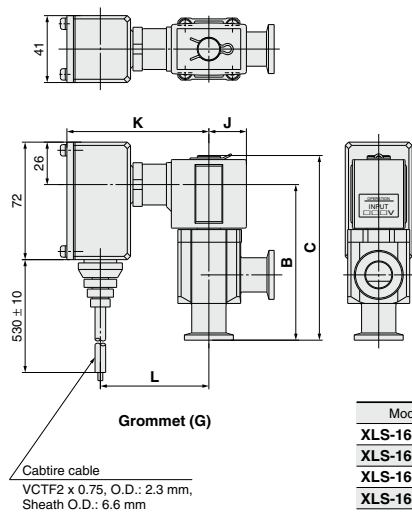

											(mm)	
Model	A	B	C	D	E	F	G	J	K	L	M	
XLS-16-□G	40	104	113	38	30	35	17	23	—	—	25.5	
XLS-16-□C		96							41	—	—	
XLS-16-□D		129	60						48	—		
XLS-16-□T			95						62	—		
XLS-25-□G	50	128.5	138.5	48	40	40	26	25.5	—	—	28	
XLS-25-□C		121.5							43	—	—	
XLS-25-□D		120.5	63						51	—		
XLS-25-□T			121.5						97	66	—	
XLS-16-P□G	40	96	113	38	30	35	17	23	87	66.5	—	
XLS-25-P□G	50	121.5	138.5	48	40	40	26	25.5	89.5	69	—	

XL□ Series Common Option

1 Heater

Valve heaters are common for models **XLA, XLC, XLD, XLF, XLG** and **XLH**.
Power consumption specifications are shown in the below table.

Item		XL□-25	XL□-40	XL□-50	XL□-63	XL□-80	XL□-100	XL□-160	
Rated heater voltage		90 to 240 VAC							
Heater assembly quantity used Heater power W (Nominal value) In-rush/Power consumption (Option symbol-Operating voltage)	Heater assembly quantity	—	1 pc.	1 pc.	1 pc.	1 pc.	2 pcs.	3 pcs.	
	H4 100°C	100V	—	200/40	200/50	400/100	600/150	800/220	1200/350
		200V	—	800/40	800/50	1600/100	2400/150	3200/220	4800/350
	Heater assembly quantity		1 pc.	1 pc.	1 pc.	1 pc.	2 pcs.	3 pcs.	4 pcs.
	H5 120°C	100V	200/40	400/70	400/80	600/130	800/180	1200/300	1600/400
		200V	800/40	1600/80	1600/80	2400/130	3200/180	4800/300	6400/400

- * The inrush current of the heater flows for several ten seconds when using 100V while it flows for several seconds when using 200V. However, this inrush current decreases momentarily.
- * When the valve uses multiple heater assemblies, do not turn ON the power to each heater assembly at the same time. Turn ON the power to each heater assembly one-by-one in order at intervals of 30 sec. since the inrush current is large.
- * The heater temperature will decrease several % from the start of heating and then becomes stable. (The heater temperature may decrease approximately 5 to 10% due to individual differences.)
- * Refer to "Maintenance Parts" on page 465 for further details regarding quantity and type.

Inrush current flow time (Reference)

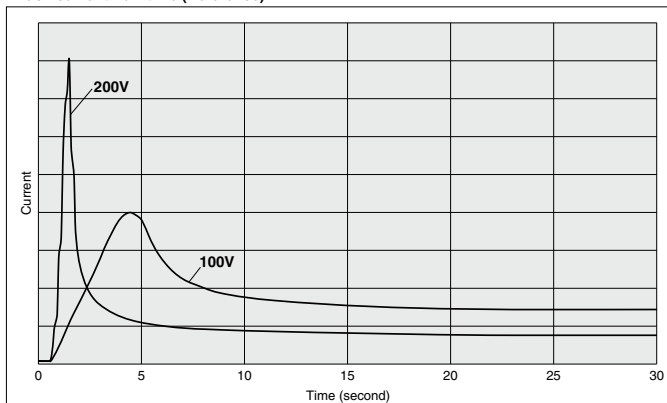

XLA

XL□

XL□Q

XM□

XY□

D-□

XSA

XVD

XGT

CYV

XL Series

Glossary

1 Seal Materials

Please note that the following are general features and subject to change depending on processing conditions. For details, please contact sealing component manufacturers.

FKM (Fluororubber)

With low outgassing, low permanent-setting and low gas permeation rates, this is the most popular seal material for high vacuums. Standard material used by SMC's high vacuum angle valve is Mitsubishi Cable Industries, Ltd. (Compound No. 1349-80).

It is advisable to choose a model depending on its application, because an improved material compound (3310-75) which reduces the weight reduction ratio with O₂ plasma is also available.

Kalrez[®] * Kalrez[®] is a registered trademark of E. I. du Pont de Nemours and Company or its affiliates. This material, perfluoroelastomer (FFKM), has excellent heat and chemical resistance, but its permanent-setting is large, and special caution is required. Variations are available with improved plasma (O₂, CF₄) and particulate resistance; therefore it is advisable to select types based upon the application. Compound No. 4079: Standard Kalrez[®], excellent in gas and heat resistance.

Chemraz[®] * Chemraz[®] is a registered trademark of Greene, Tweed Technologies, Inc. This material, perfluoroelastomer (FFKM), has excellent chemical and plasma resistance and has slightly higher heat resistance than FKM. Several variations of Chemraz[®] are available and it is advisable to choose based upon the particular plasma being used and other conditions, etc.

Compound No. SS592: Excellent physical properties and especially effective for moving parts.

Compound No. SS630: Applicable to both fixed and moving parts and compatible with a wide variety of applications.

Compound No. SSE38: The cleanest material among Chemraz[®], developed for high-density plasma instruments.

Barrel Perfluoro[®] * Barrel Perfluoro[®] is a registered trademark of Matsumura Oil Co., Ltd. Compound No. 70W: Perfluoroelastomer (FFKM) which does not contain a metal filler. Resistant against NF₃, NH₃. Low particle generation under dry process conditions.

ULTIC ARMOR[®] * ULTIC ARMOR[®] is a registered trademark of Nippon Valqua Industries, Ltd. Fluoro-based rubber which does not contain a metal filler. Seal material which is plasma-resistant and has low gas emittance and heat resistance.

Silicone (Silicone rubber, VMQ)

This material is relatively inexpensive, has good plasma resistance, but its gas permeation rate is high.

Optional seal material used by SMC's high vacuum angle valve is Mitsubishi Cable Industries, Ltd. (Compound No. 1232-70, White)

It has a low weight-reduction ratio and low particle generation within O₂ plasma and NH₃ gas environments.

EPDM (Ethylenepropylene rubber)

Relatively lower priced and excellent in weatherability, chemical and heat resistance, but with no resistance at all to general mineral oil. Optional seal material used by SMC's high vacuum angle valve is Mitsubishi Cable Industries, Ltd. (Compound No. 2101-80)

Resistant to NH₃ gas, etc.

2 Shaft Sealing Method

Bellows

Bellows offer cleaner sealing with reduced particle generation and less outgassing. The two major bellow types are: Formed-bellows and Welded-bellows. Formed-bellows produce less dusts and offer higher dust resistance. Welded-bellows allow longer strokes, but generate more dust particles and offer less dust resistance. Please note, the endurance depends on length and speed of the strokes.

O-ring, etc.

Due to entrainment of gases and generation of particulates, vacuum performance is somewhat inferior to the bellows type. However, high speed operation is possible and durability is comparatively high. In general, fluorinated grease is affixed to the shaft seal portion.

3 Response Time/Operation Time

Valve opening

The time from the application of voltage to the actuation solenoid valve (XL) until 90% of the valve stroke has been completed is the valve opening response time. Valve opening operation time indicates the time from the start of the stroke until 90% of movement has been completed. Both of these become faster as the operating pressure is increased.

Valve closing

The time from the cut off of power to the actuation solenoid valve (XL) until 90% of the valve return stroke has been completed is the valve closing response time. Valve closing operation time indicates the time from valve opening until 90% of return movement has been completed. Both of these become slower as the operating pressure is increased.

4 Molecular Flow Conductance

Orifice conductance

In the case of a ϕA (cm^2) hole in an ultra-thin plate, conductance "C" results from "V", the average velocity of the gas; "R", the gas constant; "M", the molecular weight; and "T", the absolute temperature. From the formula $C=11.6A$ (L/sec) at an air temperature of 20°C.

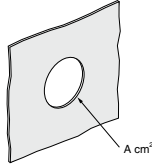

Cylinder conductance

With length "L" (cm) and diameter "D" (cm) where $L \gg D$, from the formula $C=(2\pi RT/M)^{0.5}D^3/6L$, the conductance $C=12.1 D^3/L$ (L/sec) at an air temperature of 20°C.

Short pipe conductance

From the Clausing's factor "K" and hole conductance "C" in Graph 1. (Clausing's factor drawing), the short pipe conductance C_K is easily found as $C_K=KC$.

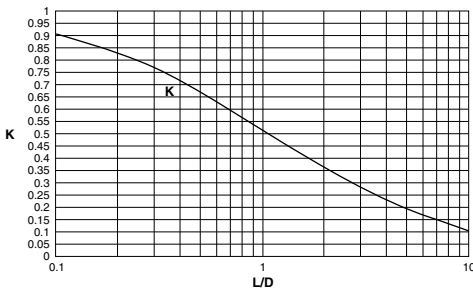

Graph 1. Clausing's factor

Conductances combined

When each of the separate conductances are given as C_1 , C_2 and C_n , the composite conductance ΣC is expressed as:
 $\Sigma C=1/(1/C_1+1/C_2+\dots+1/C_n)$ when in series, and
 $\Sigma C=C_1+C_2+\dots+C_n$, when in parallel.

5 He Leakage

Surface leakage

This leakage occurs between surfaces of the sealing and the seal material. In the case of elastic body seal (elastomer), leakage values are confirmed within minutes of operation. Leakage rate is measured at room temperature (20 to 30°C).

Gas permeation

This is leakage caused by diffusion through the elastic body seal material. As temperature increases, the diffusion rate increases, and in many cases, becomes greater than surface leakage. The diffusion rate is proportional to the cross-sectional area (cm^2) of the seal, and inversely proportional to the seal width (distance between the atmosphere and the vacuum side). In the case of metal gaskets, only hydrogen diffusion should be considered.

6 Outgassing

This is a phenomenon where gases adhered or adsorbed to the metallic surface or its inside parts are released from the surface and drawn into the vacuum according to the pressure decrease. The smoothness of the surface and closeness of the oxidized layer can effect (increase/decrease) this.

7 Ultimate Pressure

Ultimate pressure P (Pa) is $P=Q/S$, where the sum of Weight flow rates for outgassing (Qg) and leakage Q(L) is $Q(Pa \cdot m^3/s)$, and the exhaust speed is S(m^3/s). The ultimate pressure is measured with Qg, Q(L/S) shown as above, and the ultimate pressure of the pump itself. In the case of very low pressure, the exhaust characteristics of the actual pump can be the limiting factor. In particular, a deterioration of exhaust characteristics due to an unclean pump and invasion of the atmospheric moisture can be the major factor.

8 Exhaust Time (Low/Medium Vacuum)

The time (Δt) required to exhaust a chamber at low vacuum with volume V (L), from pressure P1 to P2, using a pump with pumping speed S (L/sec) is $\Delta t=2.3(V/S)\log(P1/P2)$. In high vacuum, this is subject to the ultimate pressure limit imposed by outgassing and leakage as characterized above.

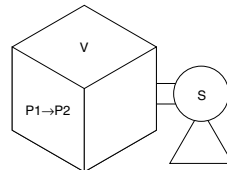

9 Baking

Gases such as oxygen and nitrogen, which have a small adsorption activation energy (E) and a short adsorption residence time (τ), are evacuated quickly. However, in the case of water, which has a high activation energy, evacuation does not progress quickly unless the temperature (T: absolute temperature) is raised to shorten residence time. This time is characterized as $\tau=\tau_0 \exp(E/RT)$ where R is the ideal gas constant and $\tau_0=(\text{approx.}) 10^{-13}$ sec.

Residence time of water at 20°C is 5.5×10^{-6} sec, whereas at 150°C, it is 2.8×10^{-9} sec, or about 200 times shorter. The objective of baking is to exhaust water with long adsorption residence time more quickly.

XLA
XL□
XL□Q
XM□
XY□
D-□
XSA
XVD
XGT
CVY



XL Series

Specific Product Precautions 1

Be sure to read this before handling the products.

Air Operated Angle Valves/XLA(V), XLC(V), XLD(V), XLF(V), XLG(V) Series

Design

⚠ Warning

• All models

1. The body material is A6063, the bellows are stainless steel 316L, and other metal seal material is stainless steel 304. Standard seal material in the vacuum section is FKM that can be changed to the other materials (please refer to "How to Order"). Use fluids which are compatible with materials after confirming.
2. Select materials for the actuation pressure piping, and heat resistance for fittings that are suitable for the applicable operating temperatures.

• Model with auto switch/XLA(V), XLC(V), XLD(V), XLF(V), XLG(V)

1. The switch section should be kept at a temperature no greater than 60°C.

• Model with heater/XLA, XLC, XLD, XLF, XLG

1. When using a model with a heater (thermistor), a device should be installed to prevent overheating.

• Model with solenoid valve/XLAV, XLCV, XLDV, XLFV, XLGV

1. For models with a solenoid valve, the temperature of the solenoid valve section should be no greater than 50°C.

Selection

⚠ Caution

• All models

1. For high vacuum valves used in the main exhaust lines of flat panel display manufacturing equipment and other large manufacturing equipment, the XLF(V) or XLG(V) series, employing O-ring seal type for improved durability, is recommended.
2. When controlling valve responsiveness, take note of the size and length of piping, as well as the flow rate characteristics of the actuating solenoid valve.
3. Actuating pressure should be kept within the specified range. 0.4 to 0.5 MPa is recommended.
4. Use within the limits of the operating pressure range.
5. The actuating piston chamber and the bellows chamber [except for XLF(V)/XLG(V)] are directly connected to atmosphere. Please use in an environment in which dust emissions will not cause problems. (Please consult SMC if the release of dust must be avoided.)

• High temperature type/XLA, XLC, XLD, XLF, XLG

1. In the case of gases which cause a large amount of deposits, heat the valve body to prevent deposits in the valve.

Mounting

⚠ Caution

• All models

1. In high humidity environments, keep valves packaged until the time of installation.
2. In case with switches and solenoid valves, secure the lead wires so that they have sufficient slack, without any unreasonable force applied to them.
3. Perform piping so that excessive force is not applied to the flange sections. In case there is vibration of heavy objects or attachments, etc., secure them so that torque is not applied directly to the flanges.

Mounting

⚠ Caution

4. Vibration resistance allows for normal operation up to 30 m/s² (45 to 250 Hz), but continuous vibration may cause a decline in durability. Arrange piping to avoid excessive vibrations or shocks.
- High temperature type (Model/XLA, XLC, XLD, XLF, XLG; Temperature specifications/H0, H2, H3)
 1. In models with heater (thermistor), take care not to damage the insulation components of the lead wires and connector section.
 2. The setting temperature for models with heater should be established without a draft or heat insulation. It will change depending on conditions such as heat retaining measures and the heating of other piping. Fine adjustment is not possible.
 3. When installing heater accessories or mounting a heater, check insulation resistance at the actual operating temperature. A short circuit breaker or fuse should be installed.
 4. When a valve is to be heated, only the body section should be heated, excluding the bonnet section.
 5. When a heater is in operation, the entire valve becomes hot. Be careful not to touch it with bare hands, as burns will result.

Piping

⚠ Caution

1. Before mounting, clean the surface of the flange seal and the O-ring with ethanol, etc.
2. There is an indentation of 0.1 to 0.2 mm in order to protect the flange seal surface, and it should be handled so that the seal surface is not damaged in any way. When using an outer ring, be sure that the O-ring is compressed sufficiently. (There is basically no problem with the outer ring.)
3. Exhaust direction

During operation, the direction of the exhaust may be determined freely, but in cases where a flow is generated by the exhaust, a decline in durability may result. The exhaust direction shown in the figure below (bellows side exhaust) is recommended. Please take all available precautions, as the life of the equipment is affected by conditions of usage.

Recommended exhaust direction [Vacuum pump connected on bellows side]

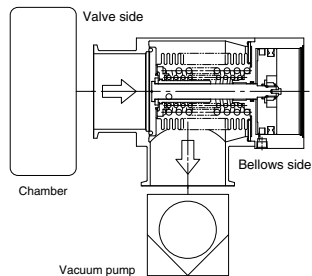

4. The valve may not be mounted depending on the piping material type (clamp, etc.). Be sure to check the piping material before use.



XL Series

Specific Product Precautions 2

Be sure to read this before handling the products.

Air Operated Angle Valves/XLA(V), XLC(V), XLD(V), XLF(V), XLG(V) Series

Maintenance

⚠ Caution

1. When removing deposits from a valve, take care not to damage any of its parts.
2. Replace the bonnet assembly when the end of its service life is approached.
3. If damage is suspected prior to the end of the service life, perform early maintenance.

Maintenance

⚠ Caution

4. SMC specified parts should be used for service. Refer to "Construction", "Replacement Parts," or "Maintenance Parts."
5. When removing valve or exterior seals, take care not to damage the sealing surfaces. When installing the valve seal, be sure that the O-ring is not twisted.

Manual Angle Valve/XLH Series

Design

⚠ Warning

1. The body material is A6063, the bellows are stainless steel 316L, other vacuum parts are stainless steel 304. FKM is the standard seal material for the vacuum part, but other materials may be selected (please refer to How to Order). Please check the material used, and use only fluids that will not interfere with the material.
2. When using a model with a heater (thermistor), a device should be installed to prevent over heating.

Piping

⚠ Caution

1. Before mounting, clean the surface of the flange seal and the O-ring with ethanol, etc.
2. There is an indentation of 0.1 to 0.2 mm in order to protect the flange seal surface, and it should be handled so that the seal surface is not damaged in any way. When using an outer ring, be sure that the O-ring is compressed sufficiently. (There is basically no problem with the outer ring.)
3. The valve may not be mounted depending on the piping material type (clamp, etc.). Be sure to check the piping material before use.

Selection

⚠ Caution

1. Use within the limits of the operating pressure range.
2. In the case of gases which cause a large amount of deposits, heat the valve body or use a model with heater to prevent deposits in the valve.

Maintenance

⚠ Caution

1. When removing deposits from a valve, take care not to damage any of its parts.
2. Replace the handle assembly when the end of its service life is approached.
3. If damage is suspected prior to the end of the service life, perform early maintenance.
4. SMC specified parts should be used for service. Refer to "Construction", "Replacement Parts," or "Maintenance Parts."
5. When removing valve or exterior seals, take care not to damage the sealing surfaces. When installing the valve seal, be sure that the O-ring is not twisted.

Mounting

⚠ Caution

1. In models with heater (thermistor), take care not to damage the insulation components of the lead wires and connector section.
2. The setting temperature for models with heater should be established without a draft or heat insulation. It will change depending on conditions such as heat retaining measures and the heating of other piping. Fine adjustment is not possible.
3. When installing heater accessories or mounting a heater, check insulation resistance at the actual operating temperature. A short circuit breaker or fuse should be installed.
4. When a valve is to be heated, only the body section (excluding handle part) should be heated.
5. In high humidity environments, keep valves packaged until the time of installation.
6. When a heater is in operation, the entire valve becomes hot. Be careful not to touch it with bare hands, as burns will result.
7. Perform piping so that excessive force is not applied to the flange sections. In case there is vibration of heavy objects or attachments, etc., secure them so that torque is not applied directly to the flanges.

XL
XL□
XL□Q
XM□ XY□
D-□
XSA
XVD
XGT
CVY



XL Series

Specific Product Precautions 3

Be sure to read this before handling the products.

Angle Solenoid Valve/XLS Series

Design

Warning

1. The body material is A6063, the bellows are stainless steel 316L, the other metal materials used in the vacuum part are 13Cr stainless steel, stainless steel 304, and A2017, and the seal material is FKM. In addition, a fluorinated resin (PFA) is used in the armature assembly of the vacuum part. The valve of the vacuum part has a fluorinated grease coating. Please check the material used, and in the course of maintenance, use only liquids that will not interfere with the material.
2. In cases without an operating power supply, the starting voltage is applied for only 0.15 to 0.2 s, and after this, a holding voltage (25% of the starting voltage) must be applied. If not performed properly, this can cause burning of the coil and fire, etc.
3. Be certain to install a fuse or short circuit breaker in the power supply circuit.

Selection

Caution

1. Use within the limits of the operating pressure range.

Mounting

Caution

1. In high humidity environments, keep valves packaged until the time of installation.
2. Please secure in such a way that the lead wire has sufficient curvature, and that no excessive force is applied to it.

Changing the entry of DIN terminal connector

After separating the terminal block and housing, the cord entry can be changed by attaching the housing in the desired direction (4 directions at 90° intervals).

Piping

Caution

1. Before mounting, clean the surface of the flange seal and the O-ring with ethanol, etc.
2. There is an indentation of 0.1 to 0.2 mm in order to protect the flange seal surface, and it should be handled so that the seal surface is not damaged in any way. When using an outer ring, be sure that the O-ring is compressed sufficiently. (There is basically no problem with the outer ring.)
3. The valve may not be mounted depending on the piping material type (clamp, etc.). Be sure to check the piping material before use.

Maintenance

Caution

1. Replace the core and armature assemblies when the end of their service life is approached.
2. If damage is suspected prior to the end of the service life, perform early maintenance.
3. SMC specified parts should be used for service parts. Refer to "Replacement Parts" on back of page 465 for further details.



XL Series

Specific Product Precautions 4

Be sure to read this before handling the products.

Maintenance Parts

Air operated angle valve/Manual valve

Caution 1. When replacing seal materials, please replace bonnet assembly or handle assembly. This may not be applicable in cases where the seal material differs from that used in the products.



Bonnet assembly



Handle assembly

Bonnet Assembly, Handle Assembly Component Parts No.: (1)

Model	Temperature specifications	Indicator	Valve size							
			16	25	40	50	63	80	100	160
XLA	General use	None	XLA16-30-1	XLA25-30-1	XLA40-30-1	XLA50-30-1	XLA63-30-1	XLA80-30-1	XLA100-30-1	XLA160-30-1
		Yes	XLA16A-30-1	XLA25A-30-1	XLA40A-30-1	XLA50A-30-1	XLA63A-30-1	XLA80A-30-1	XLA100A-30-1	XLA160A-30-1
	High temperature	None	XLA16-30-1H	XLA25-30-1H	XLA40-30-1H	XLA50-30-1H	XLA63-30-1H	XLA80-30-1H	XLA100-30-1H	XLA160-30-1H
		Yes	XLA16A-30-1H	XLA25A-30-1H	XLA40A-30-1H	XLA50A-30-1H	XLA63A-30-1H	XLA80A-30-1H	XLA100A-30-1H	XLA160A-30-1H
XLA V	General use	None	XLAV16-30-1	XLAV25-30-1	XLAV40-30-1	XLAV50-30-1	XLAV63-30-1	XLAV80-30-1	XLAV100-30-1	XLAV160-30-1
		Yes	XLAV16A-30-1	XLAV25A-30-1	XLAV40A-30-1	XLAV50A-30-1	XLAV63A-30-1	XLAV80A-30-1	XLAV100A-30-1	XLAV160A-30-1
XLC	General use	None	XLC16-30-1	XLC25-30-1	XLC40-30-1	XLC50-30-1	XLC63-30-1	XLC80-30-1	XLC100-30-1	XLC160-30-1
		High temperature	None	XLC16-30-1H	XLC25-30-1H	XLC40-30-1H	XLC50-30-1H	XLC63-30-1H	XLC80-30-1H	XLC100-30-1H
XLCV	General use	None	XLCV16-30-1	XLCV25-30-1	XLCV40-30-1	XLCV50-30-1	XLCV63-30-1	XLCV80-30-1	—	—
		High temperature	None	XLCV16-30-1H	XLCV25-30-1H	XLCV40-30-1H	XLCV50-30-1H	XLCV63-30-1H	XLCV80-30-1H	—
XLF	General use	None	XLF16-30-1	XLF25-30-1	XLF40-30-1	XLF50-30-1	XLF63-30-1	XLF80-30-1	XLF100-30-1	XLF160-30-1
		Yes	XLF16A-30-1	XLF25A-30-1	XLF40A-30-1	XLF50A-30-1	XLF63A-30-1	XLF80A-30-1	XLF100A-30-1	XLF160A-30-1
	High temperature	None	XLF16-30-1H	XLF25-30-1H	XLF40-30-1H	XLF50-30-1H	XLF63-30-1H	XLF80-30-1H	XLF100-30-1H	XLF160-30-1H
		Yes	XLF16A-30-1H	XLF25A-30-1H	XLF40A-30-1H	XLF50A-30-1H	XLF63A-30-1H	XLF80A-30-1H	XLF100A-30-1H	XLF160A-30-1H
XLFV	General use	None	XLFV16-30-1	XLFV25-30-1	XLFV40-30-1	XLFV50-30-1	XLFV63-30-1	XLFV80-30-1	XLFV100-30-1	XLFV160-30-1
		Yes	XLFV16A-30-1	XLFV25A-30-1	XLFV40A-30-1	XLFV50A-30-1	XLFV63A-30-1	XLFV80A-30-1	XLFV100A-30-1	XLFV160A-30-1
XLD	General use	None	—	XLD25-30-1	XLD40-30-1	XLD50-30-1	XLD63-30-1	XLD80-30-1	XLD100-30-1	XLD160-30-1
		High temperature	Standard	—	XLD25-30-1H	XLD40-30-1H	XLD50-30-1H	XLD63-30-1H	XLD80-30-1H	XLD100-30-1H
XLDV	General use	None	—	XLDV25-30-1	XLDV40-30-1	XLDV50-30-1	XLDV63-30-1	XLDV80-30-1	XLDV100-30-1	XLDV160-30-1
		High temperature	Standard	—	XLDV25-30-1H	XLDV40-30-1H	XLDV50-30-1H	XLDV63-30-1H	XLDV80-30-1H	XLDV100-30-1H
XLG	General use	None	XLG16-30-1	XLG25-30-1	XLG40-30-1	XLG50-30-1	XLG63-30-1	XLG80-30-1	XLG100-30-1	XLG160-30-1
		High temperature	None	XLG16-30-1H	XLG25-30-1H	XLG40-30-1H	XLG50-30-1H	XLG63-30-1H	XLG80-30-1H	XLG100-30-1H
XLGV	General use	None	XLGV16-30-1	XLGV25-30-1	XLGV40-30-1	XLGV50-30-1	XLGV63-30-1	XLGV80-30-1	—	—
		High temperature	None	XLGV16-30-1H	XLGV25-30-1H	XLGV40-30-1H	XLGV50-30-1H	XLGV63-30-1H	XLGV80-30-1H	—
XLH	Standard	Standard	XLH16-30-1	XLH25-30-1	XLH40-30-1	XLH50-30-1	—	—	—	—
		Standard	—	—	—	—	—	—	—	—

Note 1) In cases where the valve seal material is other than the standard (FKM: includes Compound no. 1349-80: made by Mitsubishi Cable Industries, Inc.), please add suffix symbol for seal material (Refer to the table 1 on page 465-1) at the end of the part number.
 Note 2) An auto switch magnet is not attached. In cases where an auto switch magnet is attached, please add "-M9/" (M9) for the XLC/XLG with a size of 50 or more) at the end of the part number. (Not available for high temperature models)
 Note 3) Auto switch and solenoid valve are not attached. When a set including auto switch and solenoid valve is required, please add the symbols after the auto switch in "How to Order" at the end of the part number.

Exterior Seal, (M) Valve Seal, S Valve Seal Assembly

Model	Description Construction No.	Material	Valve size							
			16	25	40	50	63	80	100	160
XLA(V) XLD(V) XLH	Exterior seal (3)	Standard	AS568-025V	AS568-030V	AS568-035V	AS568-039V	AS568-043V	AS568-045V	AS568-050V	AS568-167V
		Special	AS568-025□	AS568-030□	AS568-035□	AS568-039□	AS568-043□	AS568-045□	AS568-050□	AS568-167□
XLF(V) XLG(V)	Exterior seal (3)	Standard	XLF16-6	XLF25-6	AS568-035V	AS568-039V	AS568-043V	AS568-045V	AS568-050V	AS568-167V
		Special	—	—	AS568-035□	AS568-039□	AS568-043□	AS568-045□	AS568-050□	AS568-167□
Common	Valve seal (2)	Standard	B2401-V15V	B2401-V24V	B2401-P42V	AS568-227V	AS568-233V	B2401-V85V	AS568-349V	B2401-G155V
		Special	B2401-V15□	B2401-V24□	B2401-P42□	AS568-227□	AS568-233□	B2401-V85□	AS568-349□	B2401-G155□
XLD(V)	S valve seal assembly (4)	Standard	—	AS568-009V	XLD40-2-9-1A	XLD50-2-9-1A	XLD63-2-9-1A	XLD80-2-9-1A	XLD100-2-9-1A	XLD160-2-9-1A
		Special	—	AS568-009□	XLD40-2-9-1A□	XLD50-2-9-1A□	XLD63-2-9-1A□	XLD80-2-9-1A□	XLD100-2-9-1A□	XLD160-2-9-1A□

Note 1) In cases where the seal material is other than the standard (FKM: includes Compound no. 1349-80: made by Mitsubishi Cable Industries, Inc.), please add suffix symbol for seal material (Refer to the table 1 on page 465-1) at the end of the part number (the place of □).
 Note 2) Refer to "Construction" of each series for component parts numbers.

Solenoid Valve/Plate Assembly

Model	Description Construction No.	Valve size							
		16	25	40	50	63	80	100	160
XLA V	Solenoid valve (8)	SYJ319-□□				SYJ519-□□			
	Plate assembly (9)	XLAV16-90-2				XLAV63-90-1			
XLFV	Solenoid valve (10)	SYJ319-□□				SYJ519-□□			
	Plate assembly (11)	XLAV16-90-2				XLAV63-90-1			
XLCV XLGV	Solenoid valve (8)	SYJ3190-□□ (single)				SY3120-□□-C4 (single)			
	Plate assembly (9)	SYJ3290-□□ (double)				SY3220-□□-C4 (double)			
XLDV	Initial exhaust solenoid valve (11)	V114-□□							
	Main exhaust solenoid valve (12)	—	V114-□□	SYJ314-□□					
	Plate assembly (13)	—	XLDV25-90-2	XLDV40-90-2					

Note 1) The □□ at the end of the solenoid valve part number is the selection symbol for voltage, electrical entry, and other specifications. For details about selection symbols, refer to the Web Catalog.
 Note 2) The plate assembly includes the plate, gasket, and mounting screws.
 Note 3) Refer to "Construction" of each series for component parts numbers.

XLA

XLD

XLF

XLFV

XLDV

XLG

XLGV

XLH

XLA V

XLF V

XLC V

XLG V

XLD V



XL Series

Specific Product Precautions 5

Be sure to read this before handling the products.

Maintenance Parts

Table 1: Seal Material Symbol

Symbol	-XN1	-XP1	-XQ1	-XR1	-XR2	-XR3	-XS1	-XT1	-XU1
Seal material	EPDM	Barrel Perfluoro®	Kalrez®		Chemraz®		VMO	FKM for Plasma	ULTIC ARMOR®
Compound no.	2101-80*	70W	4079	SS592	SS630	SSE38	1232-70*	3310-75*	UA4640

Note 1) This may not be applicable in cases where the seal material differs from that used in the products, although the seal material is changed.

* Produced by Mitsubishi Cable Industries, Ltd.

Barrel Perfluoro® is a registered trademark of Matsumura Oil Co., Ltd.

Kalrez® is a registered trademark of E. I. du Pont de Nemours and Company or its affiliates.

Chemraz® is a registered trademark of Greene, Tweed Technologies, Inc.

ULTIC ARMOR® is a registered trademark of Nippon Valqua Industries, Ltd.

Replacement Heaters

Temperature specification	Valve size						
	25	40	50	63	80	100	160
H4 (100°C heater)	—	XLA25-60S-1	XLA25-60S-1	XLA25-60S-2	XLA25-60S-3	XLA25-60S-2 (2 sets)	XLA25-60S-2 (3 sets)
H5 (120°C heater)	XLA25-60S-1	XLA25-60S-2	XLA25-60S-2	XLA25-60S-3	XLA25-60S-2 (2 sets)	XLA25-60S-2 (3 sets)	XLA25-60S-2 (4 sets)

Example) In the case of a replacement heater for XLC-80-H5, two sets of XLA25-80M-2 are required.

Angle Solenoid Valve

Construction No.	Description	XLS16-□□	XLS16-P□□	XLS25-□□	XLS25-P□□
②	Coil assembly	XLS16-20-□G, C, T, D	XLS16-20-P□G	XLS25-20-□G, C, T, D	XLS25-20-P□G
⑥	Core assembly	XLS16-30-1		XLS25-30-1	
④	Armature assembly	XLS16-30-2		XLS25-30-2	
③-1	O-ring	AS568-018V		AS568-018V	
③-2	O-ring	AS568-025V		AS568-030V	

Note 1) In case of coil assembly, please enter voltage symbol in □.

* "S" after □ is grommet, "C" for conduit, "T" for terminal, and "D" for DIN.

Note 2) Refer to "Construction" for component parts numbers.