



BREVINI[®]

Motion Systems

CARTRIDGE VALVES / IN-LINE VALVES

Technical Catalogue

November
2019

web edition



Section index **i**











Index and technical information	i
Pressure relief valves	1
Sequence, pressure reducing and unloading valves	2
Double cross relief valves	3
One-way check valves	4
Pilot check valves	5
Manual and pneumatic operated valves	6
End-off stroke valves	7
Solenoid valves 2-way	8
Solenoid valves 3-4 way	9
Diverter valves	10
Soft start valves	11
Flow control valves	12
Hand pumps	13
Valve housings	14
Cavities	15
Standard plugs	16
Coils	17
Connectors	18

© 2019 Dana Motion Systems Italia S.r.l. Tutti i diritti riservati. Hydr-App, SAM Hydraulik, Aron, Brevini Hydraulics, BPE Electronics, VPS Brevini, OT Oiltechnology, sono marchi o marchi registrati di Dana Motion Systems Italia S.r.l. o da altre società Dana in Italia ed in altri paesi.

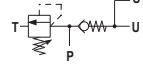
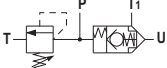
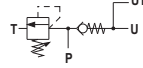
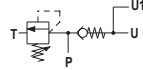
Le caratteristiche tecniche fornite nel presente catalogo non sono impegnative e non sarà possibile basare alcun procedimento legale su tale materiale. Dana non sarà responsabile per informazioni e specifiche che possano indurre ad errori o errate interpretazioni. Data la continua ricerca tecnologica volta a migliorare le caratteristiche tecniche dei nostri prodotti, Dana si riserva il diritto di apportarvi senza alcun preavviso le modifiche che riterrà opportuno. E' vietata la riproduzione anche parziale senza la specifica autorizzazione scritta di Dana. Questo catalogo sostituisce i precedenti.

L'utilizzo dei prodotti riportati su questo catalogo deve essere effettuato nel rispetto dei limiti di funzionamento riportati nelle specifiche tecniche, valutando il tipo di applicazione e le condizioni di funzionamento normali o in caso di avaria, in modo da non pregiudicare la sicurezza di persone e/o cose.

1 PRESSURE RELIEF VALVES (PAGE 13)

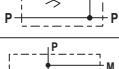
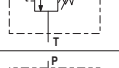
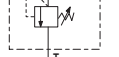
Code	Thread	Flow (l/min)	Symbol	Description	Page
CMP-HPV	M14x1.5	5		DIRECT ACTING PRESSURE RELIEF VALVES (FOR HPV VALVES)	14
CMP-MR/MW	M15x1	6		DIRECT ACTING PRESSURE RELIEF VALVES (FOR POWER PACKS SERIES MR/MW)	15
CMP02	M16x1	20		DIRECT ACTING PRESSURE RELIEF VALVES	16
CMP04	3/4-16UNF	30		DIRECT ACTING PRESSURE RELIEF VALVES	17
CMPR04 (serie 2)	3/4-16UNF	30		DIRECT ACTING PRESSURE RELIEF VALVES WITH ONE-WAY CHECK VALVE	18
CPMK04	3/4-16UNF	10		DIRECT ACTING PRESSURE RELIEF VALVES WITH LOGIC VALVE	20
CMPR04 (serie 1)	3/4-16UNF	20		DIRECT ACTING PRESSURE RELIEF VALVES WITH ONE-WAY CHECK VALVE	22
CMPHR04	3/4-16UNF	15		DIRECT ACTING HIGH PRESSURE RELIEF VALVES WITH ONE-WAY CHECK VALVE	23
CPMC04	M18x1.5	30		DIRECT ACTING PRESSURE RELIEF VALVES	24
CMP-MC/MS	M18x1.5	20		DIRECT ACTING PRESSURE RELIEF VALVES (FOR POWER PACKS SERIES MC/MS)	25
CMP06	M20x1.5	30		DIRECT ACTING PRESSURE RELIEF VALVES	26
CP06	7/8-14UNF	50		DIRECT ACTING PRESSURE RELIEF VALVES	27
CMP20	M33x2	80		DIRECT ACTING PRESSURE RELIEF VALVES	28
CMP30	M22x1.5	100		PILOT OPERATED PRESSURE RELIEF VALVES	29
VMP02	1/4" BSP	30		DIRECT ACTING PRESSURE RELIEF VALVES IN-LINE MOUNTING	30
VMP06	3/8" BSP	50		DIRECT ACTING PRESSURE RELIEF VALVES IN-LINE MOUNTING	31
VMP10	3/8" BSP	40		DIRECT ACTING PRESSURE RELIEF VALVES IN-LINE MOUNTING	32

1 PRESSURE RELIEF VALVES (PAGE 13)

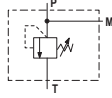
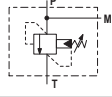
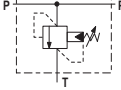
Code	Thread	Flow (l/min)	Symbol	Description	Page
VMP20	1/2" BSP	80		VALVOLE DI MASSIMA PRESSIONE AD AZIONE DIRETTA MONTAGGIO IN LINEA	33
VMP30	3/4" BSP	100		VALVOLE DI MASSIMA PRESSIONE AD AZIONE PILOTATA MONTAGGIO IN LINEA	34
VMP12	BSP: 3/4" - 1"	150		VALVOLE DI MASSIMA PRESSIONE AD AZIONE PILOTATA MONTAGGIO IN LINEA	35



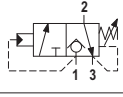
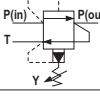
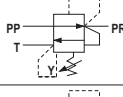
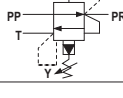
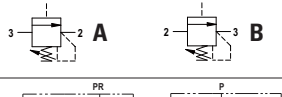
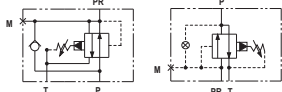

2 SEQUENCE, PRESSURE REDUCING AND UNLOADING VALVES (PAGE 37)

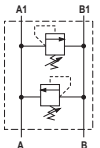
Code	Thread	Flow (l/min)	Symbol	Description	Page
CSQ04	3/4-16UNF	30		SEQUENCE VALVES - DIRECTLY OPERATED	38
CSMK04	3/4-16UNF	10		SEQUENCE VALVES - DIRECTLY OPERATED (FOR MK3 SERIES POWER PACKS)	39
CVS20	M22x1.5	90		SEQUENCE VALVES - PILOT OPERATED	40
CVR06	7/8-14UNF	20		PRESSURE REDUCING VALVES WITH RELIEVING - DIRECT OPERATED	41
CVR20	M22x1.5	150		PRESSURE REDUCING VALVES WITH RELIEVING - PILOT OPERATED	42
CVE06	7/8-14UNF	30		SEQUENCE VALVES	43
CRC1	1/2" BSP	90		PRESSURE REDUCING AND SEQUENCE VALVES IN-LINE MOUNTING	44

3 DOUBLE CROSS RELIEF VALVES (PAGE 45)

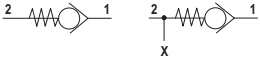
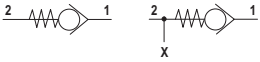
Code	Thread	Flow (l/min)	Symbol	Description	Page
VADIL	BSP: 1/4" - 3/8"	30		DOUBLE CROSS RELIEF VALVES DIRECT ACTING IN-LINE MOUNTING	46

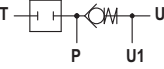
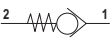
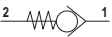
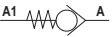
4 ONE-WAY CHECK VALVES (PAGE 47)

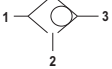
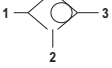
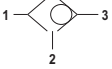
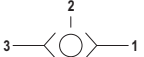
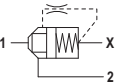
Code	Thread	Flow (l/min)	Symbol	Description	Page
CRU-MR	M15x1	10		ONE-WAY CHECK VALVES	48
CRU-MC/MS	M16x1.5	20		ONE-WAY CHECK VALVES	49
CRU04	3/4-16UNF	40		ONE-WAY CHECK VALVES	50
CRU06	7/8-14UNF	60		ONE-WAY CHECK VALVES	51
CRI04	3/4-16UNF	20		ONE-WAY CHECK VALVES (FOR POWER PACKS SERIES FP)	52
VR06	3/8" BSP	30		ONE-WAY CHECK VALVES	53
VUI	BSP: 1/4" - 3/8" - 1/2"	20 - 50 - 80		ONE-WAY CHECK VALVES	54
VRU	BSP: 1/4" - 3/8" 1/2" - 3/4 - 1" 1" 1/4 - 1" 1/2	20 - 35 - 50 80 - 140 200 - 310		ONE-WAY CHECK VALVES IN-LINE MOUNTING	55
VUBA	BSP: 1/4" - 3/8" 1/2" - 3/4	4 - 6.3 16 - 25		CHECK VALVES FOR PIPES	56
SH01	M8x1	2		SHUTTLE VALVES	58
SH02	1/8" BSP	8		SHUTTLE VALVES	59
SH03	1/4" BSP	5		SHUTTLE VALVES	60
RVLV0	M16x1.5	7		SHUTTLE VALVES	61
RVLV1	M27x1.5	140		PUMP UNLOADING VALVES	62

5 PILOT CHECK VALVES (PAGE 63)

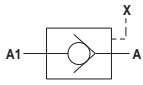
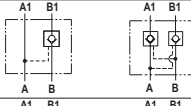
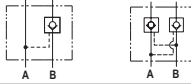
Code	Thread	Flow (l/min)	Symbol	Description	Page
VRS	1/4" BSP BSP: 1/4" - 3/8" - 1/2" - 3/4"	12 - 30 45 - 85		SINGLE ACTING PILOTED CHECK VALVES	64
VBPSA-VBPDA	BSP: 1/4" - 3/8" 1/2" - 3/4" 9/16-18 UNF	20 - 25 45 - 85		SINGLE AND DOUBLE ACTING PILOT CHECK VALVES	65
VBPSA-VBPDA DIN	BSP: 1/4" - 3/8"	20 - 25		SINGLE AND DOUBLE ACTING PILOT CHECK VALVES-DIN 2353 PORTS	67

6 MANUAL AND PNEUMATIC OPERATED VALVES (PAGE 69)

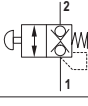
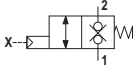
Code	Thread	Flow (l/min)	Symbol	Description	Page
CMF04	3/4-16UNF	15		LEVER OPERATED VALVES	70
CPE04	3/4-16UNF	30		BUTTON OPERATED VALVES	71
CRD04P	3/4-16UNF	30		PNEUMATIC OPERATED VALVES	72

7 END-OFF STROKE VALVES (PAGE 73)

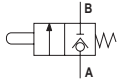
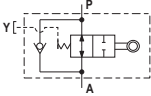
Code	Thread	Flow (l/min)	Symbol	Description	Page
VFC	3/8" BSP	40		END-OFF STROKE VALVES IN-LINE MOUNTING	74
VD40	1/2" BSP	40		DECELERATION VALVES IN-LINE MOUNTING	75

8 SOLENOID VALVES 2-WAY (PAGE 77)

Code	Thread	Flow (l/min)	Symbol	Description	Page
CRB04	3/4-16UNF	40		PILOTED OPERATED CARTRIDGE SOLENOID VALVE BIDIRECTIONAL	78
CRP04	3/4-16UNF	40		PILOTED OPERATED CARTRIDGE SOLENOID VALVE UNIDIRECTIONAL	78
CRP04HP	3/4-16UNF	30		HIGH PRESSURE PILOTED OPERATED CARTRIDGE SOLENOID VALVE	80
CRD04	3/4-16UNF	15 - 30		DIRECT OPERATED CARTRIDGE SOLENOID VALVE	82
C2V04	3/4-16UNF	15		CARTRIDGE SOLENOID VALVES 2 WAY 2 POSITIONS	84

9 SOLENOID VALVES 3-4 WAY (PAGE 85)

Code	Thread	Flow (l/min)	Symbol	Description	Page
C3V0422	3/4-16UNF	12		SOLENOID VALVES 3-WAY/2-POSITION	86
C3V0427	3/4-16UNF	20		SOLENOID VALVES 3-WAY/2-POSITION	87
C3V03	7/8-14UNF	20		SOLENOID VALVES 3 WAY 2 POSITIONS	88
C4V0422*2	3/4-16UNF	18		SOLENOID VALVES 4 WAY 2 POSITIONS	89
C4V0422*3	3/4-16UNF	18		SOLENOID VALVES 4 WAY 3 POSITIONS	90

11 DIVERTER VALVES (PAGE 91)

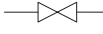
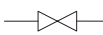
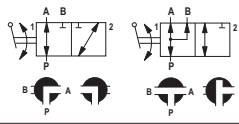
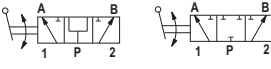
Code	Thread	Flow (l/min)	Symbol	Description	Page
MR	1/4" BSP 1/4"BSPT	—		PRESSURE GAUGE SHUT-OFF IN-LINE MOUNTING	92
RBS	BSP: 1/8" - 1/4" 3/8" - 1/2" - 3/4" 1" - 1 1/4" - 1 1/2"	5 - 10 - 25 40 - 100 - 150		HIGH PRESSURE - 2 WAY BALL VALVES IN-LINE MOUNTING	93
BK3	BSP: 1/8" - 1/4" 3/8" - 1/2" - 3/4" 1" - 1 1/4" - 1 1/2"	5 - 10 - 25 70 - 100 - 150		HIGH PRESSURE - 3 WAY BALL VALVES IN-LINE MOUNTING	94
DDF	BSP: 1/4" - 3/8" 1/2" - 3/4" - 1"	60 - 90 120 - 200		DIVERTER VALVES IN-LINE MOUNTING	95

12 SOFT START VALVES (PAGE 97)

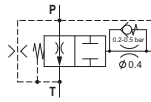
Code	Thread	Flow (l/min)	Symbol	Description	Page
VAM04	1/4" BSP	20		SINGLE-PHASE MOTOR START VALVE IN-LINE MOUNTING	98
VAMS04	1/4" BSP	8		SOFT START VALVE IN-LINE MOUNTING	99

13 FLOW CONTROL VALVES (PAGE 101)

Code	Thread	Flow (l/min)	Symbol	Description	Page
SU/SB	M10x1	15		UNIDIRECTIONAL AND BIDIRECTIONAL FLOW REGULATOR VALVES	102
VSU	1/4" BSP	20		FIXED UNIDIRECTIONAL FLOW CONTROL VALVE	103
CSB04	3/4-16UNF	40		BIDIRECTIONAL NOT COMPENSATED FLOW CONTROL VALVE	104
CSC04	3/4-16UNF	29		UNIDIRECTIONAL COMPENSATED FLOW CONTROL VALVE	105
VSC04	1/4" BSP	11,7		FIXED PRESSURE COMPENSATED FLOW CONTROL VALVE	106
VSC06	3/8" BSP	18,5		PRESSURE COMPENSATED FLOW CONTROL VALVES	107
CRF06	7/8-14UNF	50		PRIORITY FLOW CONTROL VALVE	108
CCI06	7/8-14UNF	80		PRESSURE COMPENSATOR VALVE	109
CCP20	M22x1.5	50		TWO-WAY PRESSURE COMPENSATOR VALVE	110
VSR/VSB	BSP: 1/4" - 3/8" 1/2" - 3/4" - 1"	15 - 30 45 - 85 - 100		SLEEVE FLOW CONTROL VALVES UNIDIRECTIONAL AND BIDIRECTIONAL - IN-LINE MOUNTING	111
STU/STB	BSP: 1/4" - 3/8" 1/2" - 3/4" - 1"	20 - 30 50 - 85 - 150		UNIDIRECTIONAL AND BIDIRECTIONAL FLOW REGULATOR VALVES - IN-LINE MOUNTING	112
STC	3/8" BSP	29		PRESSURE COMPENSATED FLOW UNIDIRECTIONAL FLOW REGULATOR VALVES - IN-LINE MOUNTING	113

14 HAND PUMPS (PAGE 115)

Code	Thread	Flow (l/min)	Symbol	Description	Page
CPM04	3/4-16UNF	1cc - 2cc		HAND PUMP	116

VALVE	PAGE	VALVE	PAGE
BK3	94	MR	92
C2V04	84	RBS	93
C3V03	88	RVLV0	61
C3V0422	86	RVLV1	62
C3V0427	87	SH01	58
C4V0422*2	89	SH02	59
C4V0422*3	90	SH03	60
CCI06	109	STC	113
CCP20	110	STU/STB	112
CMF04	70	SU/SB	102
CMP02	16	VADIL	46
CMP04	17	VAM04	98
CMP06	26	VAMS04	99
CMP20	28	VBPSA-VBPDA	65
CMP30	29	VBPSA-VBPDA DIN	67
CMP-HPV	14	VD40	75
CMPHR04	23	VFC	74
CMP-MC/MS	25	VMP02	30
CMP-MR/MW	15	VMP06	31
CMPR04 (serie 1)	22	VMP10	32
CMPR04 (serie 2)	18	VMP12	35
CP06	27	VMP20	33
CPE04	71	VMP30	34
CPM04	116	VR06	53
CPMC04	24	VRS	64
CPMK04	20	VRU	55
CRB04 / CRP04	78	VSC04	106
CRC1	44	VSC06	107
CRD04	82	VSR/VSB	111
CRD04P	72	VSU	103
CRF06	108	VUBA	56
CRI04	52	VUI	54
CRP04HP	80		
CRU04	50		
CRU06	51		
CRU-MC/MS	49		
CRU-MR	48		
CSB04	104		
CSC04	105		
CSMK04	39		
CSQ04	38		
CVE06	43		
CVR06	41		
CVR20	42		
CVS20	40		
DDF	95		
		Section index	1
		Technical information	10
		Valve housings	118
		Cavities	122
		Standard plugs	130
		Coils	134
		Connectors	140

INTRODUCTION

Read this instructions carefully before installation. All operations must be carried out by qualified personnel following the instructions.

The user must periodically inspect, based on the conditions of use and the substances used, the presence of corrosion, dirt, the state of wear and correct function of the valves.

Always observe first the operating conditions given in datasheet of the valve.

HYDRAULIC FLUID

Observe the recommendations given in the data sheet of the valve. Use only mineral oil (HL, HLP) according to DIN 51524. Use of other different fluids may damage the good operation of the valve.

VISCOSITY

Observe the recommendations given in the data sheet of the valve. The oil viscosity must be in the range of 10 mm²/s to 500 mm²/s. Recommended oil viscosity 46 mm²/s (32 mm²/s for Cartridge valves)

Table 1: ISO viscosity grades

Viscosity grade	Average kinematic viscosity mm ² /s @ 40°C	Kinematic-viscosity limits mm ² /s @ 40°C	
		min.	max.
ISO VG 10	10	9.00	11.0
ISO VG 15	15	13.5	16.5
ISO VG 22	22	19.8	24.2
ISO VG 32	32	28.8	35.2
ISO VG 46	46	41.4	50.6
ISO VG 68	68	61.2	74.8
ISO VG 100	100	90.0	110

= Values used in the chart "Oil viscosity according to temperature"

CONVERSION TABLE SSU / °E / mm²/s

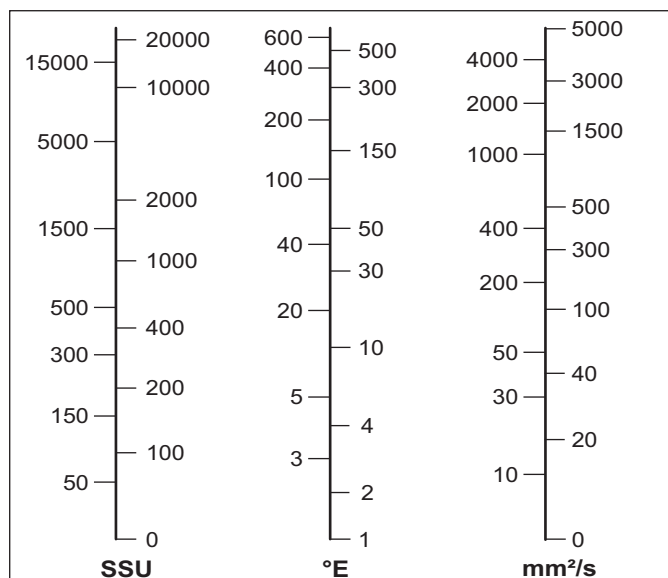

OIL VISCOSITY ACCORDING TO TEMPERATURE

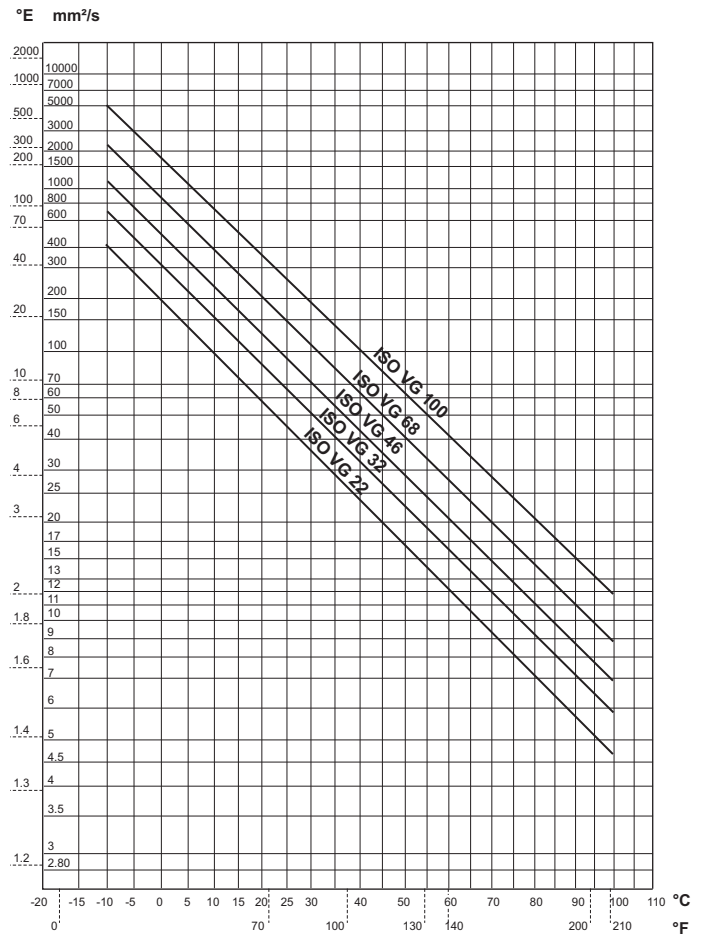

CONTAMINATION

Oil contamination is the main cause of faults and malfunction in hydraulic systems. Abrasive particles in the fluid erode or block moving parts, leading to system malfunction.

The valves we are offering do not require filtering characteristics any higher than those needed for usual hydraulic components such as pumps, motors, etc.

However, accurate filtering does guarantee reliability and a long life to all the system's hydraulic parts. Reliable performance and long working life for all oil-pressure parts is assured by maintaining the level of fluid contamination within the limits specified in the data sheet of the valve.

Hydraulic fluid must also be cleaned properly before filling the hydraulic circuit, especially when commissioning a new system, as this is when the oil contamination generally peaks due to its flushing effect on the components, and the running-in of the pump.

Maximum contamination level is required on datasheet of the valve according to ISO 4406:1999.

In the following table there is the correspondence between ISO 4406:1999 and old standard NAS 1638 for information purpose:

The standard ISO 4406:1999 defines the contamination level with three numbers that relate with the number of particles of average dimension equal or greater than 4 µm, 6 µm e 14 µm, in 1 ml of fluid.

In following table there is a reference to recommended contamination level and correspondence with old NAS 1638 standard.

Table 2: Recommended contamination level.

Type of system Type of valve	Oil filtration recommendations		
	Cleanliness class recommended		Absolute filtration micron rating (**)
	ISO 4406 : 1999	NAS 1638 (*)	
Systems or components operating at HIGH PRESSURE > 250 bar (3600 psi) HIGH DUTY CYCLE APPLICATIONS Systems or components with LOW dirt tolerance	18 / 16 / 13	7 - 8	5
Systems or components operating at MEDIUM / HIGH PRESSURE Systems and components with moderate dirt tolerance	19 / 17 / 14	9	10
Systems or components operating at LOW PRESSURE < 100 bar (1500 psi) LOW DUTY CYCLE APPLICATIONS Systems and components with GOOD dirt tolerance	20 / 18 / 15	10 - 11	20

* Contamination class NAS 1638: it is determined by counting the total particles of different size ranges contained in 100 ml of fluid.

** Absolute filtration: it is a characteristic of each filter, it refers the size (in micron) of the largest spherical particle which may pass through the filter.

WORKING TEMPERATURES

Ambient temperature range: -25°C to +60°C

Fluid temperature range (NBR seals): -25°C to +75°C

Thermal shocks can affect the performance and the expected life of the product, hence it is necessary to protect the product from these conditions.

SEALS

O-rings made in Acrylonitrile Butadiene (NBR) are normally fitted on the valves. The backup rings that protect the O-rings are also made in NBR, or sometimes PTFE. Both the O-rings and the backup rings are suitable for the working temperatures mentioned above.

In the case of fluid temperatures > 75°C, FKM seals must be used (identified with "V1" variant).

ELECTRICAL POWER SUPPLY

Solenoid valves coils are designed to operate safely in the voltage range of ±10% of nominal voltage at max. 60°C ambient temperature. The combination of permanent overvoltage and very hot temperatures can stress the solenoid. Therefore always a good heat dissipation and voltage level has to be assured. Faulty coils may only be replaced by new, interchangeable, tested compo-

nents in original-equipment quality.

Before removing a coil, voltage must be disconnected.

When replacing the coil, be aware to insert O-Rings in order to avoid the entrance of water.

INSTALLATION

The mounting surface must feature surface quality specified in data sheet of the valve: for example for Cetop valves generally is required $Ra \leq 1.6\mu m$ and flatness ≤ 0.03 mm over 100 mm length. Normally in cartridge valve for sealing diameters of the cavities, is required roughness $Ra \leq 1.6\mu m$. The surfaces and openings in the assembly plate must be free from impurity or dirt.

Make sure the O-Rings fit correctly in their seats.

Fixing screws must comply with the dimensions and the strength class specified in the data sheet and must be tightened at the specified tightening torque.

Complete the electrical wiring. For circuit examples and pin assignments, see the relevant datasheet.

USE AND MAINTENANCE

Observe the functional limits indicated in the technical catalogue

On a periodic basis and based on the conditions of use, check for cleanliness, state of wear or fractures and correct performance of the valve.

If the O-rings are damaged, replace them with those supplied by the manufacturer.

To assure the best working conditions at all time, check the oil and replace it periodically (after the first 100 working hours and then after every 2000 working hours or at least once every year).

Attention: all installation and maintenance intervention must be performed by qualified staff.

TRANSPORT AND STORAGE

The valve must be handled with care to avoid damage caused by impact, which could compromise its efficiency.

In the case of storage, keep the valves in a dry place and protect against dust and corrosive substances.

When storing for periods of more than 6 months, fill the valve with preserving oils and seal it.

CONVERSION CHART

Type	SI units		Alternative units		Conversion factor
Force	Newton	(N) [kgm/s ²]	Kilogram force	(kgf)	1 kgf = 9.807 N
			pound force	(lbf) [lbf/s ²]	1 lbf = 4.448 N
Length	millimeter	(mm) [10 ⁻³ m]	inch	(in)	1 in = 25.4 mm
	meter	(m)	yard	(yd) [3ft]	1 m = 1.0936 yd
	kilometer	(km) [1000 m]	mile	(mile) [1760 yd]	1 mile = 1.609 km
Torque	Newton meter	(Nm)	pound force.feet	(lbf.ft)	1 lbf.ft = 1.356 Nm
Power	kiloWatt (kW)	[1000 Nm/s]	horsepower	(hp)	1 kW = 1.341 hp
			metric horsepower	(CV)	1 kW = 1.36 CV
Pressure	MegaPascal	(MPa) [N/mm ²]	bar		1 MPa = 10 bar
			psi (lbf/in ²)		1 MPa = 145 psi
			ton/f/in ²		1 ton/f/in ² = 15.45 MPa
Flow rate	liter/min	(l/min)	UK gal/min		1 UK gal/min = 4.546 l/min
			US gal/min		1 US gal/min = 3.785 l/min
Temperature	Degrees Celsius	(°C)	Fahrenheit	(°F)	1°F = 1.8 °C+32

i

PRESSURE RELIEF VALVES

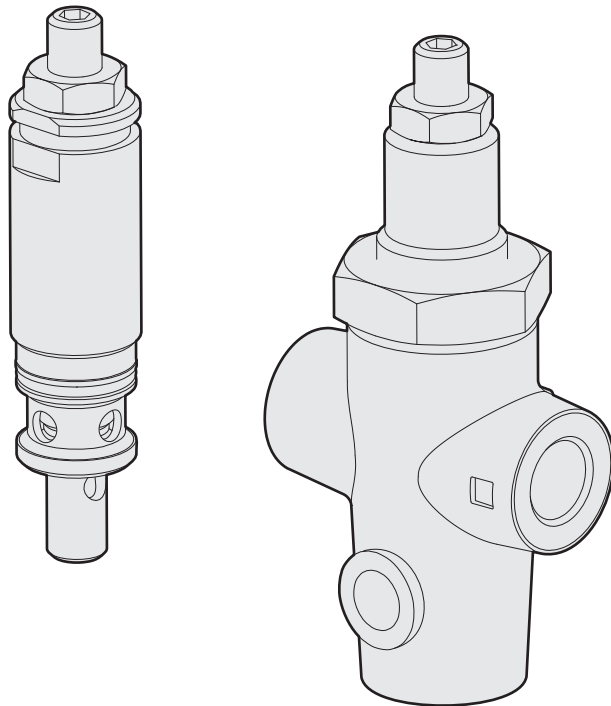

DIRECT ACTING PRESSURE RELIEF VALVES (FOR HPV VALVES)

1

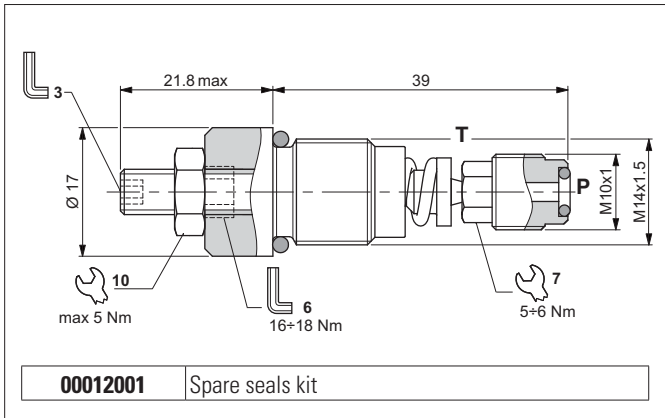

The direct acting relief valve limits the pressure in a hydraulic circuit to within the specified calibration range. It has a galvanised steel body. The tapered poppet is in tempered steel.

HYDRAULIC FEATURES

Max. working pressure	400 bar
Max. Flow	5 l/min
Hydraulic fluid	DIN 51524 Mineral oils
Fluid viscosity	10 ÷ 500 mm ² /s
Fluid temperature	-25°C ÷ 75°C
Ambient temperature	-25°C ÷ 60°C
Max. contamin. level class with filter	ISO 4406:1999 - class 19/17/14
Weight	0.038 kg
Tightening torque	see draw
Cavity (M14x1.5)	CN032005 (See section 17)

HYDRAULIC SYMBOL

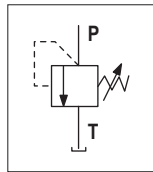

ORDERING CODE

Code	Description
RKVL1130002	Direct acting relief valve

PRESSURE-FLOW RATE

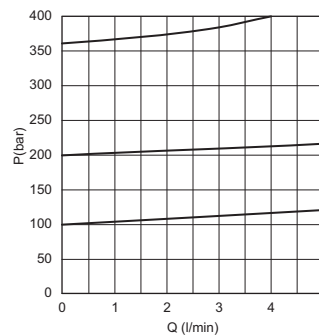

MIN.SETTING PRESSURE

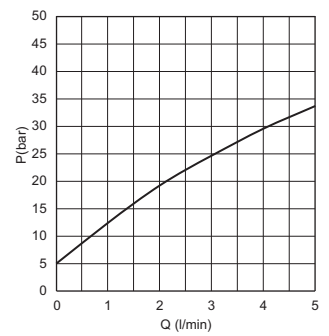

Fluid used: mineral based oil with viscosity 46 mm²/s at 40°C.

DIRECT ACTING PRESSURE RELIEF VALVES (FOR POWER PACKS SERIES MR/MW)

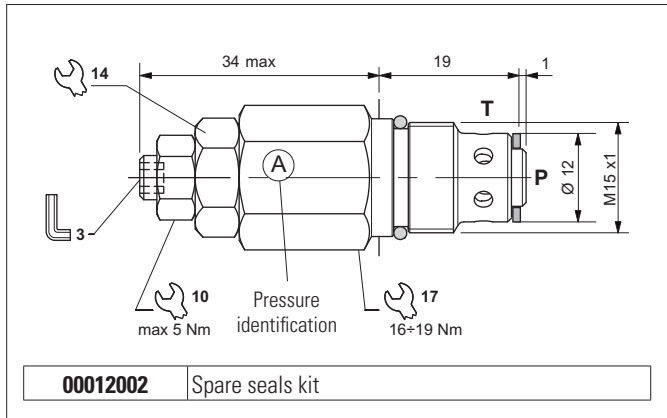

The direct acting relief valve limits the pressure in a hydraulic circuit. It raises the safety level by making it impossible for the plant operators to set a higher pressure rating, than that specified in the catalogue. It has a pack spring with a mechanical stop. It has a galvanised steel body. The guided ball poppet is in tempered and ground steel.

1

HYDRAULIC FEATURES

Max. working pressure	220 bar
Setting range:	
Spring A	25 ÷ 80 bar
Spring B	75 ÷ 220 bar
Spring C	5 ÷ 30 bar
Max. Flow	6 l/min
Hydraulic fluid	DIN 51524 Mineral oils
Fluid viscosity	10 ÷ 500 mm ² /s
Fluid temperature	-25°C ÷ 75°C
Ambient temperature	-25°C ÷ 60°C
Max. contamin. level class with filter	ISO 4406:1999 - class 19/17/14
Weight	0.05 kg
Tightening torque	see draw
Cavity (M15x1)	CN033001 (See section 17)

HYDRAULIC SYMBOL

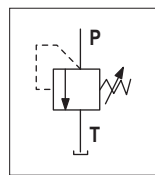

ORDERING CODE

Code	Identification (see draw)	Setting range	Pressure increasing at each turn of screw
21000010.000	A	25 ÷ 80 bar	17 bar ± 10%
21000011.000	B	75 ÷ 220 bar	45 bar ± 10%
21000009.000	C	5 ÷ 30 bar	7 bar ± 10%

The minimum permissible setting pressure depending on the spring: see curves below

PRESSURE-FLOW RATE

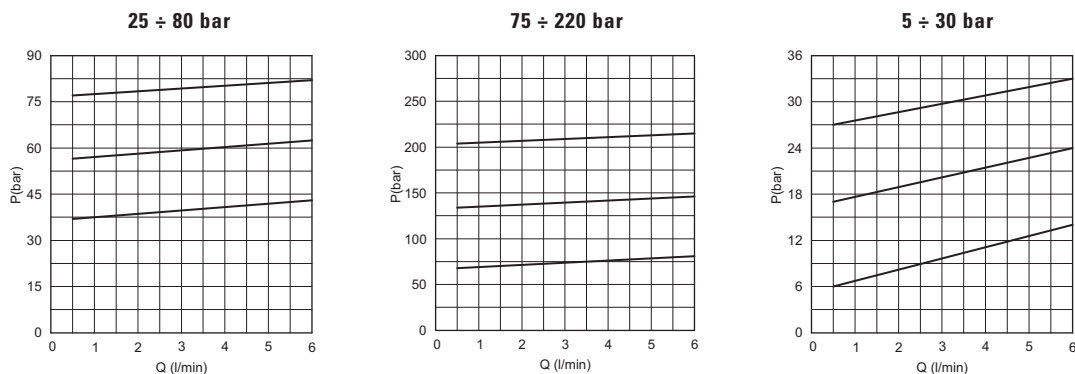

Fluid used: mineral based oil with viscosity 32 mm²/s at 50°C.

DIRECT ACTING PRESSURE RELIEF VALVES

1

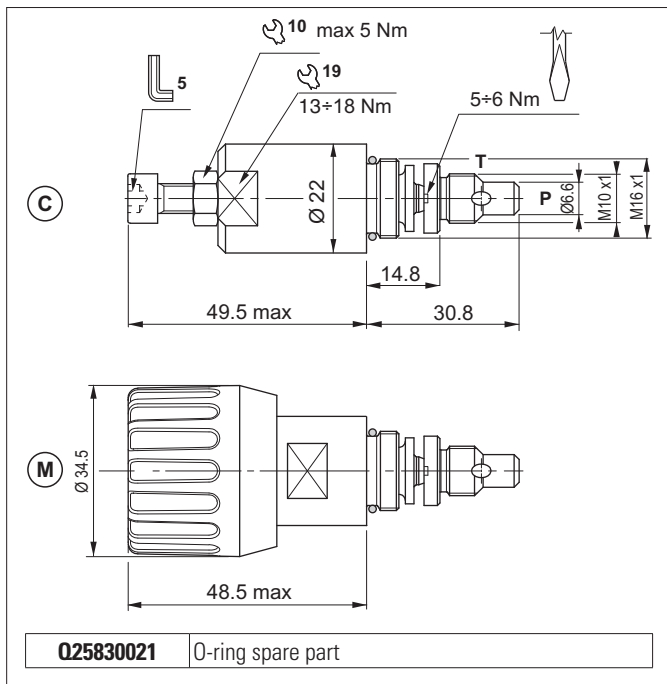

The direct acting relief valve limits the pressure in a hydraulic circuit. It raises the safety level by making it impossible for the plant operators to set a higher pressure rating, than that specified in the catalogue. This is limited by a pack spring with a mechanical stop (only standard screw and nut), which prevents temporary P closures caused by pressure peaks. It has a galvanised steel body. The guided ball poppet is in tempered and ground steel.

HYDRAULIC FEATURES

Max. working pressure	250 bar
Setting range:	
Spring 1 (white)	max 30 bar
Spring 2 (yellow)	max 90 bar
Spring 3 (green)	max 180 bar
Spring 4 (orange)	max 250 bar
Max. Flow	20 l/min
Hydraulic fluid	DIN 51524 Mineral oils
Fluid viscosity	10 ÷ 500 mm ² /s
Fluid temperature	-25°C ÷ 75°C
Ambient temperature	-25°C ÷ 60°C
Max. contamin. level class with filter	ISO 4406:1999 - class 19/17/14
Weight	0.1 kg
Tightening torque	see draw
Cavity (M16x1)	CN036001 (See section 17)

HYDRAULIC SYMBOL

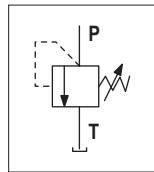

PRESSURE-FLOW RATE

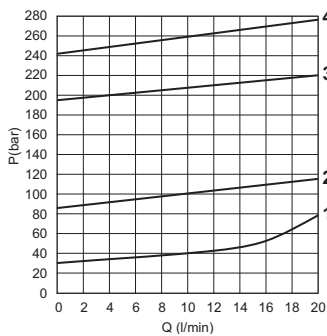

MIN.SETTING PRESSURE

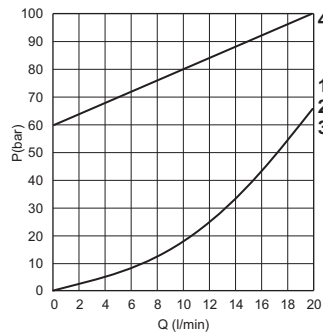

1 = CMP02C1.. - 2 = CMP02C2.. - 3 = CMP02C3.. - 4 = CMP02C4..
Fluid used: mineral based oil with viscosity 46 mm²/s at 40°C.

The minimum permissible setting pressure depending on the spring: see curves below

ORDERING CODE

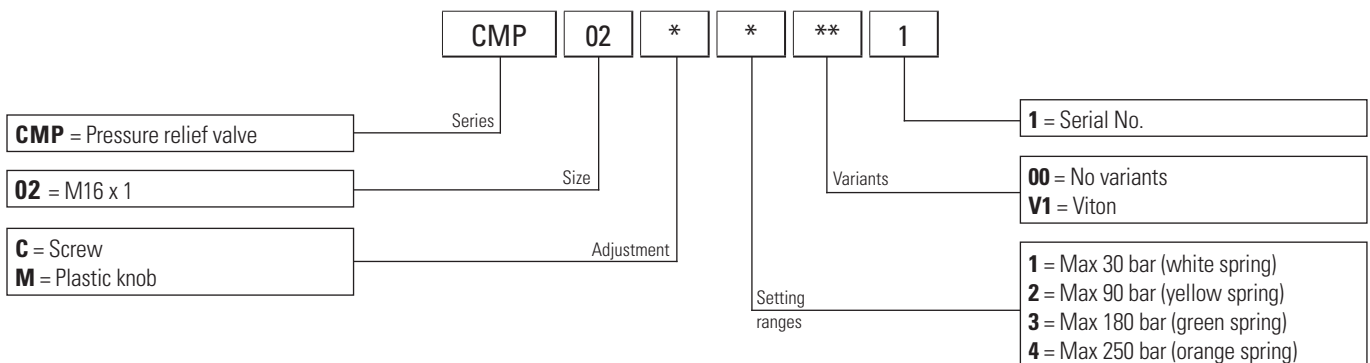

DIRECT ACTING PRESSURE RELIEF VALVES

1

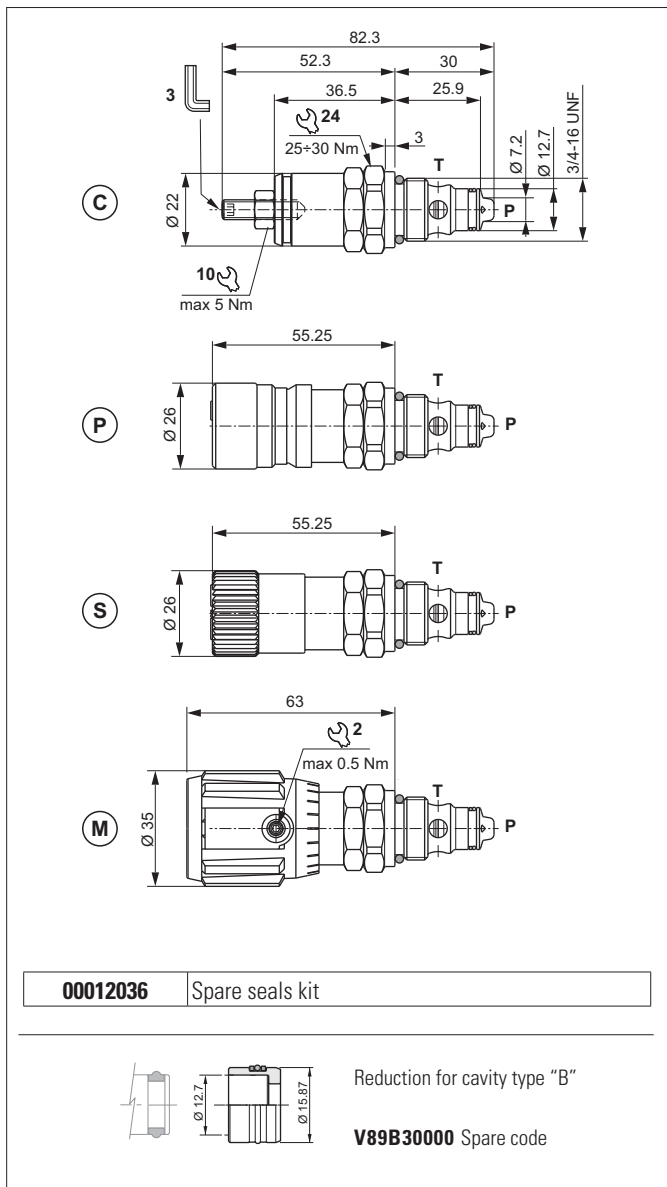

The direct acting relief valve limits the pressure in a hydraulic circuit. It raises the safety level by making it impossible for the plant operators to set a higher pressure rating, than that specified in the catalogue. It has a pack spring with a mechanical stop. It has a galvanised steel body. The guided ball poppet is in tempered and ground steel.

HYDRAULIC FEATURES

Max. working pressure	350 bar
Setting range:	
Spring 0 (white)	max 50 bar
Spring 1 (green)	max 110 bar
Spring 2 (yellow)	max 220 bar
Spring 3 (red)	max 350 bar
Max. Flow	30 l/min
Hydraulic fluid	DIN 51524 Mineral oils
Fluid viscosity	10 ÷ 500 mm ² /s
Fluid temperature	-25°C ÷ 75°C
Ambient temperature	-25°C ÷ 60°C
Max. contamin. level class with filter	ISO 4406:1999 - class 19/17/14
Weight	0.15 kg
Tightening torque	25 ÷ 30 Nm
Cavity (3/4 - 16 UNF)	CD018006 (See section 17)

The minimum permissible setting pressure depending on the spring: see curves below

PRESSURE-FLOW RATE

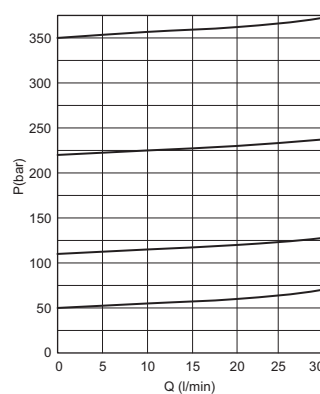

MIN. SETTING PRESSURE

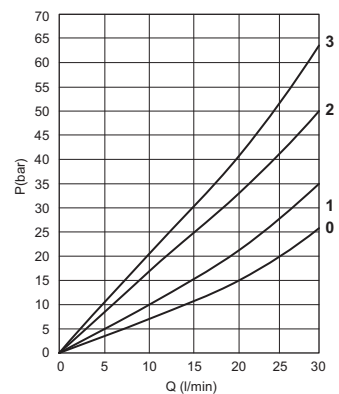

0 = CMP04*0 - 1 = CMP04*1.. - 2 = CMP04*2.. - 3 = CMP04*3..
 Fluid used: mineral based oil with viscosity 46 mm²/s at 40°C.

HYDRAULIC SYMBOL

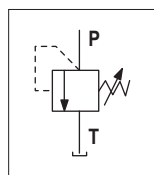

ORDERING CODE

Series: **CMP** | Size: **04** | Tip side: ***** | Adjustment: ***** | Setting ranges: **00** | Variants: **2**

- CMP** = Pressure relief valve
- 04** = 3/4 - 16 UNF
- A** = Standard - Ø 12.7 mm
- B** = With reduction - Ø 15.9 mm
- C** = Screw
- P** = C + Plug no detachable closing (unremovable version)
- S** = C + Plug detachable closing
- M** = Plastic knob
- 2** = Serial No.
- 00** = No variants
- 0** = Max 50 bar (white spring)
- 1** = Max 110 bar (green spring)
- 2** = Max 220 bar (yellow spring)
- 3** = Max 350 bar (red spring)

DIRECT ACTING PRESSURE RELIEF VALVES WITH ONE-WAY CHECK VALVE

1

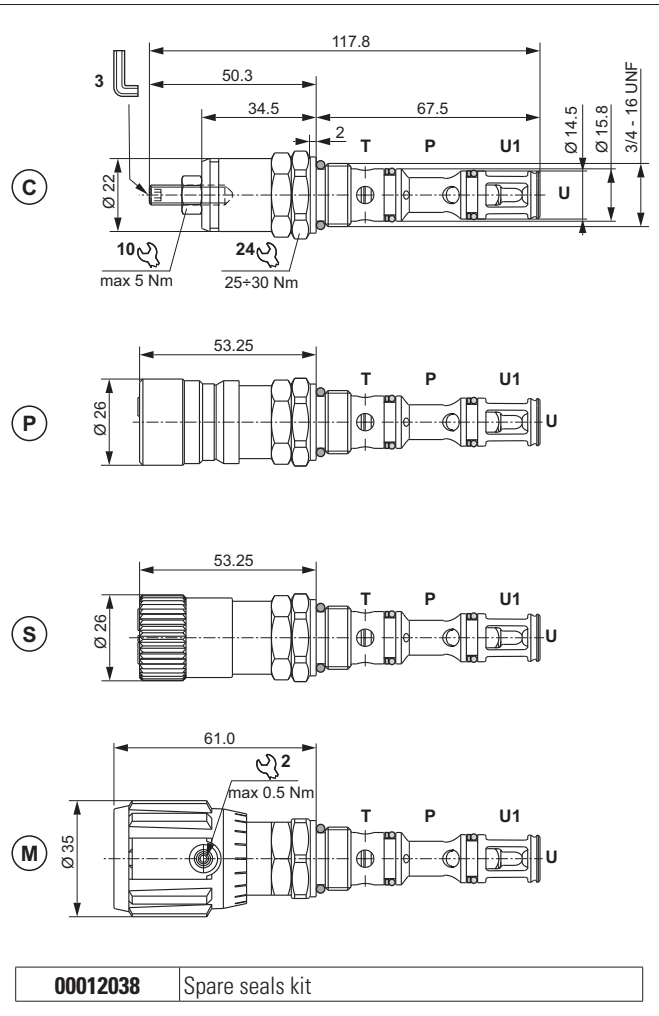

HYDRAULIC SYMBOL

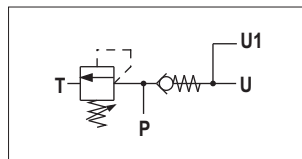

The valve has a combined function in a single cartridge. It consists of a direct acting maximum pressure valve and a unidirectional check valve. The relief valve raises the safety level by making it impossible for the plant operators to set a higher pressure rating, than that specified in the catalogue. It has a pack spring with a mechanical stop.

The spring in the check valve enables the cartridge to be mounted in any position.

It has a galvanised steel body. The tapered poppet of the relief valve and the guided ball poppet are made from tempered and ground steel.

HYDRAULIC FEATURES

Max. working pressure	350 bar
Max. Flow	30 l/min
Setting range:	
Spring 0 (white)	max 50 bar
Spring 1 (green)	max 110 bar
Spring 2 (yellow)	max 220 bar
Spring 3 (red)	max 350 bar
One-way check valve	0,5 bar (standard)
Check valve leakage (0 ÷ 5 drops/min)	0 ÷ 0.25 cm ³ /min
Hydraulic fluid	DIN 51524 Mineral oils
Fluid viscosity	10 ÷ 500 mm ² /s
Fluid temperature	-25°C ÷ 75°C
Ambient temperature	-25°C ÷ 60°C
Max. contamin. level class with filter	ISO 4406:1999 - class 19/17/14
Weight	0.15 kg
Tightening torque	25 ÷ 30 Nm
Cavity (3/4 - 16 UNF)	CD018013 (See section 17)

PRESSURE DROPS (P → U)

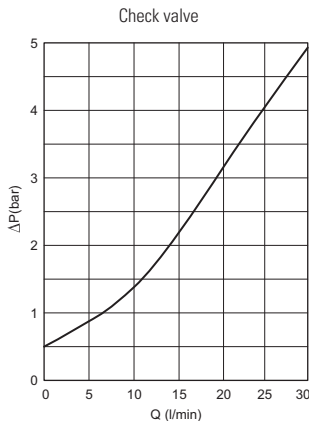

MIN. SETTING PRESSURE (P → T)

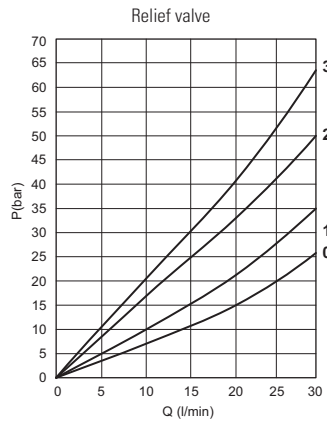

PRESSURE - FLOW (P → T)

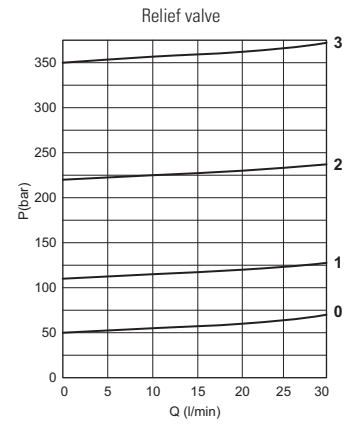

0 = CMPR04*0 - 1 = CMPR04*1.. - 2 = CMPR04*2.. - 3 = CMPR04*3..
 Fluid used: mineral based oil with viscosity 46 mm²/s at 40°C.

ORDERING CODE

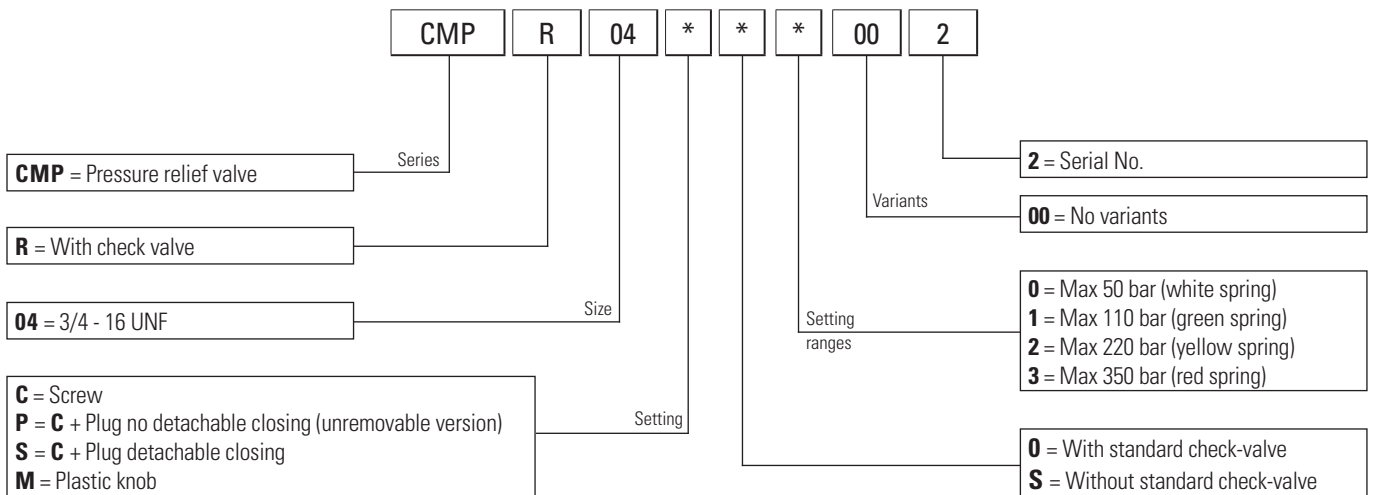

DIRECT ACTING PRESSURE RELIEF VALVES WITH LOGIC VALVE

1

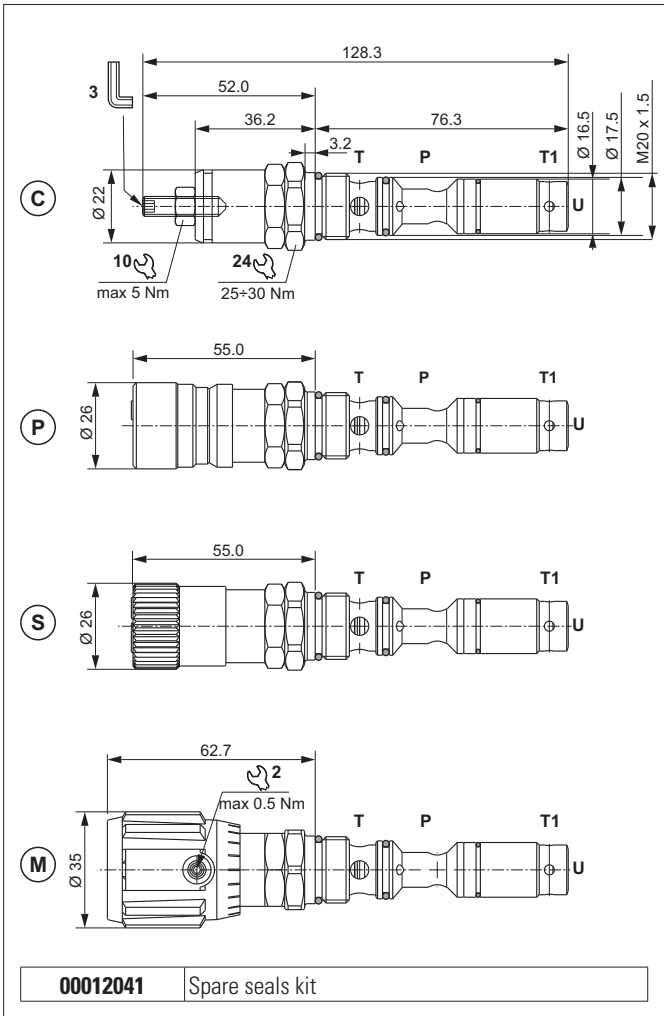

HYDRAULIC SYMBOL

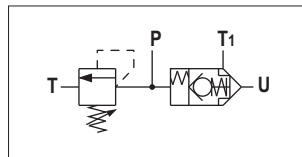

SERVICE EXAMPLE

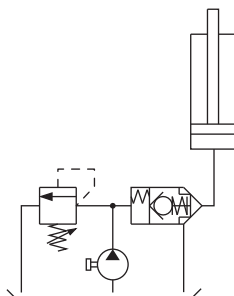

This valve provide two combined functions in a single cartridge: a direct acting pressure relief valve and a logic check valve that allow automatic flow to tank from port U when there is no flow on P port.

Pressure relief valve setting can be adjusted within the allowed pressure range, avoiding to increase the pressure over the maximum value. Springs into the check valve allow to assemble the valve in any preferred position and orientation.

Zinc plated steel housing, pressure relief valve's poppet made of tempered ground steel, check valve's ball made of tempered steel, steel logic valve poppet.

HYDRAULIC FEATURES

Max. working pressure	220 bar
Max. Flow	10 l/min
Setting range:	
Spring 0 (white)	max 50 bar
Spring 1 (green)	max 110 bar
Spring 2 (yellow)	max 220 bar
Logic valve opening pressure P → U	2,8 bar
One-way check valve U → T ₁	2,5 bar
Logic valve leakage (0 ÷ 20 drops/min)	0 ÷ 1 cm ³ /min
Hydraulic fluid	DIN 51524 Mineral oils
Fluid viscosity	10 ÷ 500 mm ² /s
Fluid temperature	-25°C ÷ 75°C
Ambient temperature	-25°C ÷ 60°C
Max. contamin. level class with filter	ISO 4406:1999 - class 19/17/14
Weight	0.17 kg
Tightening torque	25 ÷ 30 Nm
Cavity (M20 x 1,5)	CN044003 (See section 17)

PRESSURE DROPS (P → U - U → T₁)

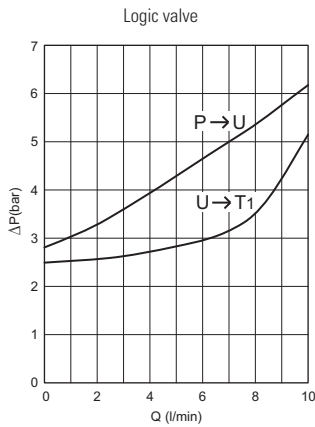

MIN. SETTING PRESSURE (P → T)

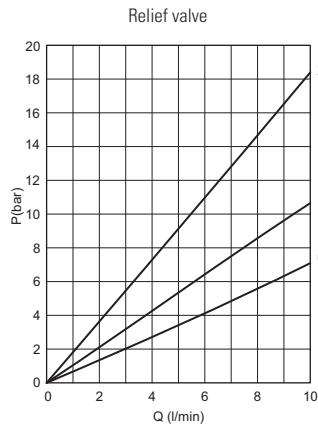

PRESSURE - FLOW (P → T)

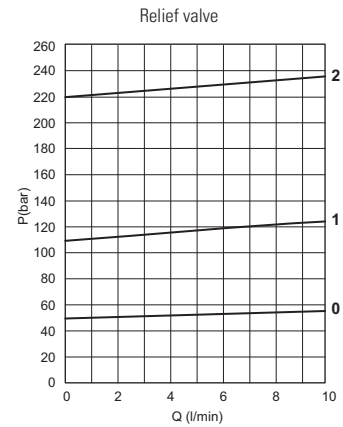

0 = CPMK04*0 - 1 = CPMK04*1.. - 2 = CPMK04*2..
 Fluid used: mineral based oil with viscosity 46 mm²/s at 40°C.

1

ORDERING CODE

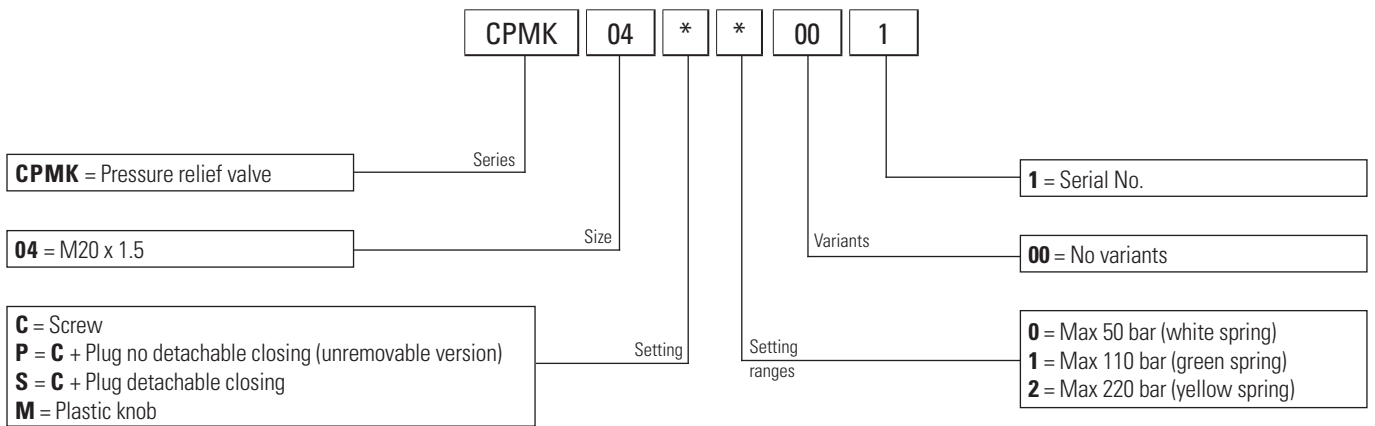

DIRECT ACTING PRESSURE RELIEF VALVES WITH ONE-WAY CHECK VALVE

1

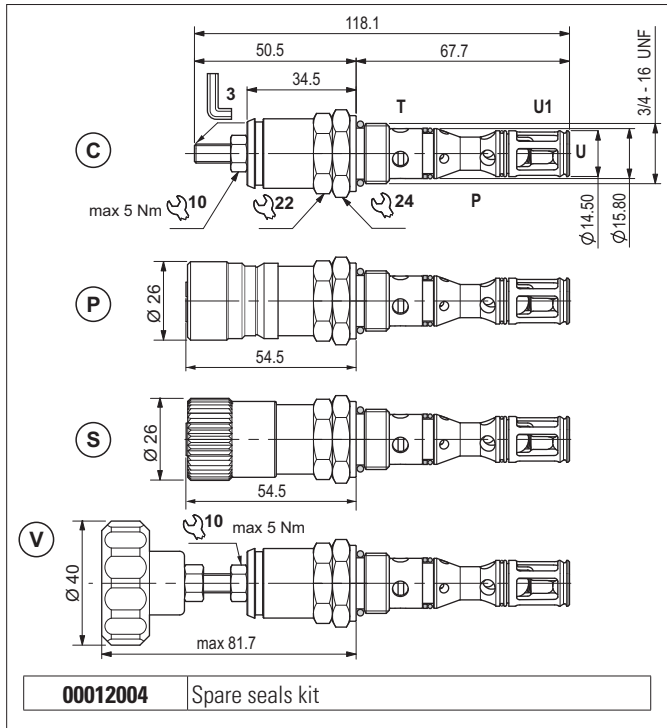

The valve has a combined function in a single cartridge. It consists of a direct acting maximum pressure valve and a unidirectional check valve. The relief valve raises the safety level by making it impossible for the plant operators to set a higher pressure rating, than that specified in the catalogue. It has a pack spring with a mechanical stop. The spring in the check valve enables the cartridge to be mounted in any position. It has a galvanised steel body. The tapered poppet of the relief valve and the guided ball poppet are made from tempered and ground steel.

HYDRAULIC FEATURES

Max. working pressure	320 bar
Max. Flow	20 l/min
Setting ranges (spring)	1 = 10 ÷ 60 bar (green) 2 = > 60 ÷ 180 bar (yellow) 3 = > 180 ÷ 320 bar (blue)
One-way check	0,5 bar (standard)
Check valve leakage (0 ÷ 5 drops/min)	0 ÷ 0.25 cm ³ /min
Hydraulic fluid	DIN 51524 Mineral oils
Fluid viscosity	10 ÷ 500 mm ² /s
Fluid temperature	-25°C ÷ 75°C
Ambient temperature	-25°C ÷ 60°C
Max. contamin. level class with filter	ISO 4406:1999 - class 19/17/14
Weight	0.18 kg
Tightening torque	25 ÷ 30 Nm
Cavity (3/4 - 16 UNF)	CD018013 (See section 17)

HYDRAULIC SYMBOL

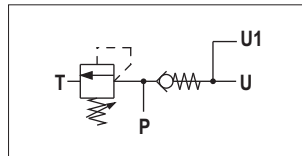

PRESSURE DROPS (P → U)

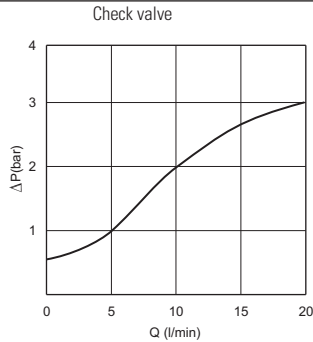

MIN. SETTING PRESSURE (P → T)

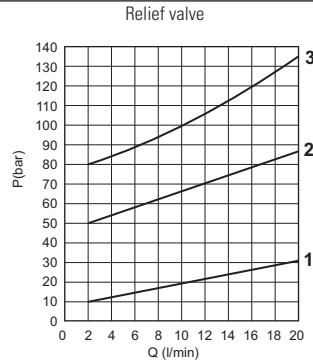

PRESSURE - FLOW (P → T)

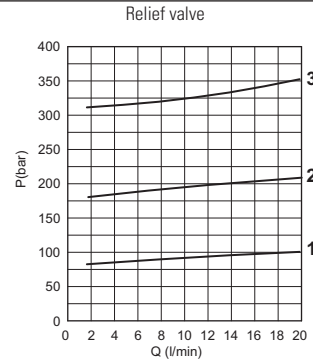

Fluid used: mineral based oil with viscosity 32 mm²/s at 50°C.

ORDERING CODE

CMP = Pressure relief valve	Series	R = With check valve	Size	04 = 3/4 - 16 UNF	Setting	* * *	Setting ranges	00 = No variants	Variants	1 = Serial No.
C = Screw		P = C + Plug no detachable closing (unremovable version)					1 = 10 ÷ 60 bar (green spring)			
S = C + Plug detachable closing		V = Handwheel					2 = > 60 ÷ 180 bar (yellow spring)			
							3 = > 180 ÷ 320 bar (blue spring)			
							0 = With standard check-valve			
							S = Without standard check-valve			

DIRECT ACTING HIGH PRESSURE RELIEF VALVES WITH ONE-WAY CHECK VALVE

1

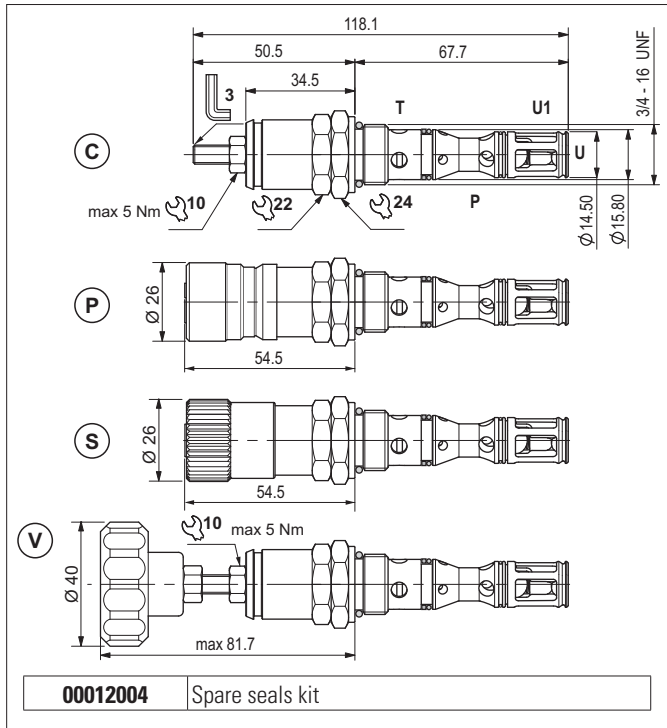

The valve has a combined function in a single cartridge. It consists of a direct acting maximum pressure valve and a unidirectional check valve. The relief valve raises the safety level by making it impossible for the plant operators to set a higher pressure rating, than that specified in the catalogue. It has a pack spring with a mechanical stop. The spring in the check valve enables the cartridge to be mounted in any position. It has a galvanised steel body. The tapered poppet of the relief valve and the guided ball poppet are made from tempered and ground steel.

HYDRAULIC FEATURES

Max. working pressure	360 bar
Max. Flow	15 l/min
Setting ranges (spring)	1 = > 320 ÷ 360 bar (blue)
One-way check	0.5 bar (standard)
Check valve leakage (0 ÷ 5 drops/min)	0 ÷ 0.25 cm ³ /min
Hydraulic fluid	DIN 51524 Mineral oils
Fluid viscosity	10 ÷ 500 mm ² /s
Fluid temperature	-25°C ÷ 75°C
Ambient temperature	-25°C ÷ 60°C
Max. contamin. level class with filter	ISO 4406:1999 - class 19/17/14
Weight	0.18 kg
Tightening torque	25 ÷ 30 Nm
Cavity (3/4 - 16 UNF)	CD018013 (See section 17)

HYDRAULIC SYMBOL

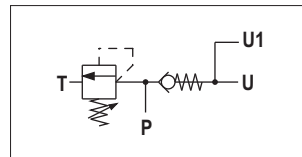

PRESSURE DROPS (P → U)

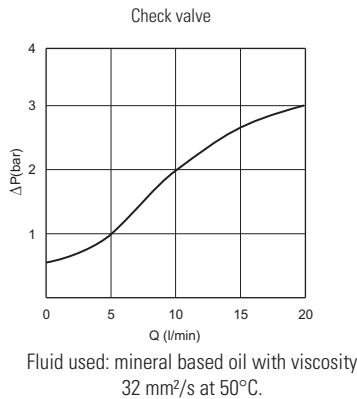

PRESSURE - FLOW (P → T)

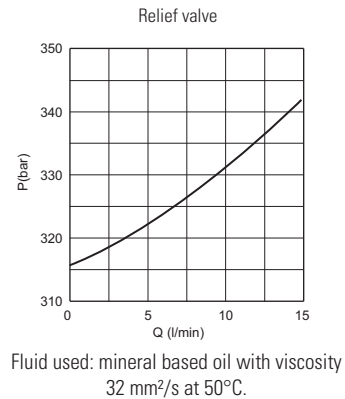

ORDERING CODE

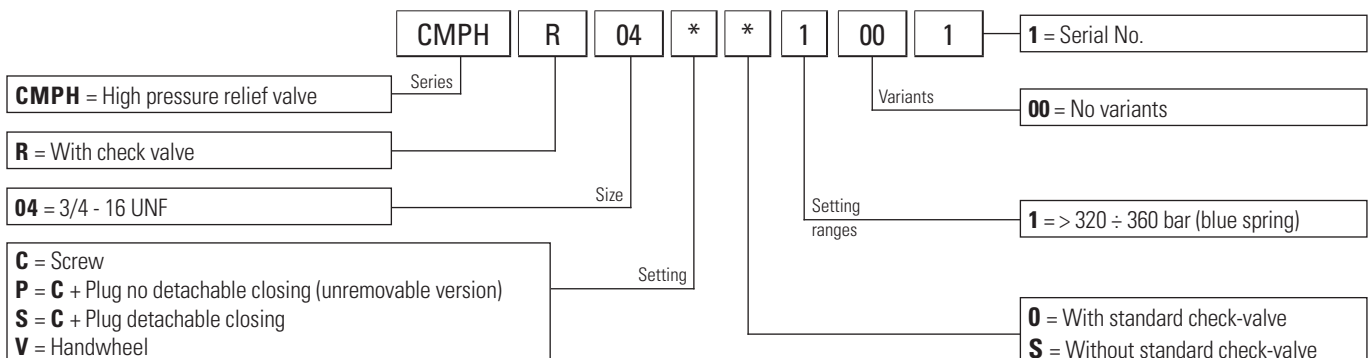

DIRECT ACTING PRESSURE RELIEF VALVES

1

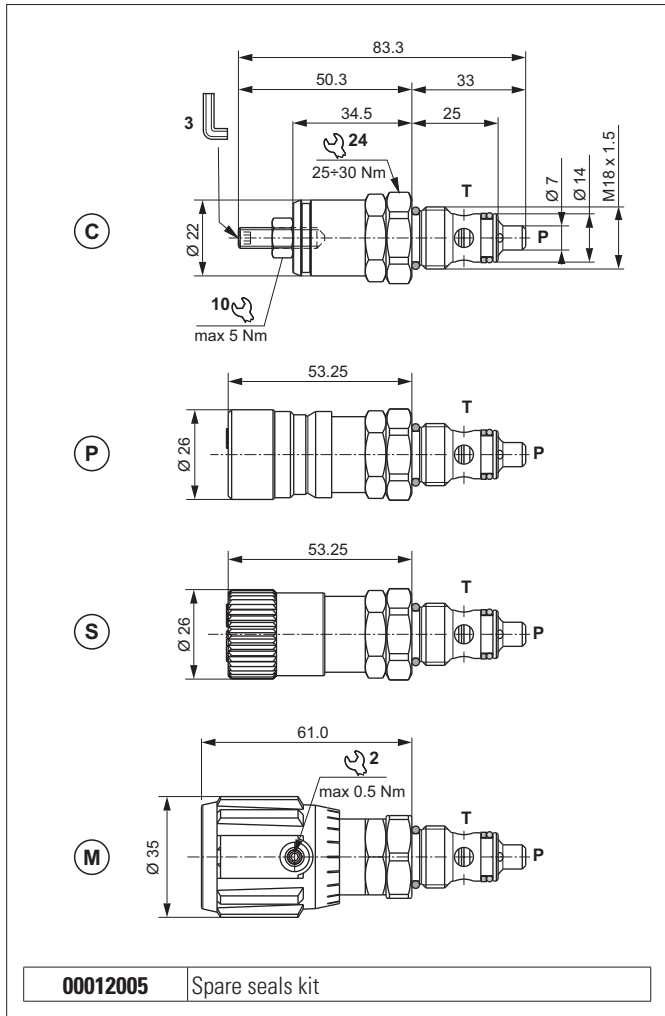

The direct acting relief valve limits the pressure in a hydraulic circuit. It raises the safety level by making it impossible for the plant operators to set a higher pressure rating, than that specified in the catalogue. It has a pack spring with a mechanical stop. It has a galvanised steel body. The guided ball poppet is in tempered and ground steel.

HYDRAULIC FEATURES

Max. working pressure	350 bar
Setting range:	
Spring 0 (white)	max 50 bar
Spring 1 (green)	max 110 bar
Spring 2 (yellow)	max 220 bar
Spring 3 (red)	max 350 bar
Max. Flow	30 l/min
Hydraulic fluid	DIN 51524 Mineral oils
Fluid viscosity	10 ÷ 500 mm ² /s
Fluid temperature	-25°C ÷ 75°C
Ambient temperature	-25°C ÷ 60°C
Max. contamin. level class with filter	ISO 4406:1999 - class 19/17/14
Weight	0.14 kg
Tightening torque	28 ÷ 32 Nm
Cavity (M18 x 1.5)	CN041009 (See section 17)

The minimum permissible setting pressure depending on the spring: see curves below

PRESSURE-FLOW RATE

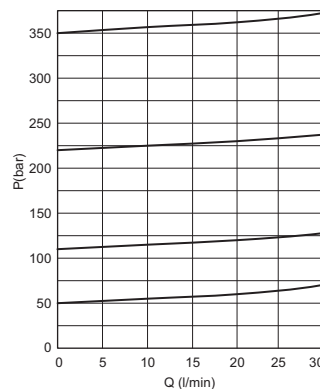

MIN. SETTING PRESSURE

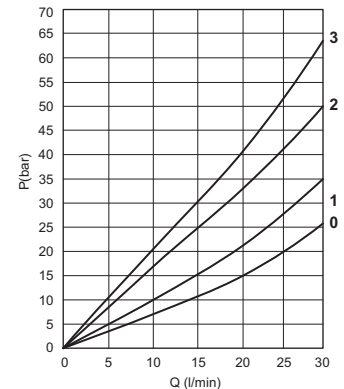

0 = CPMC04*0 - 1 = CPMC04*1.. - 2 = CPMC04*2.. - 3 = CPMC04*3..
 Fluid used: mineral based oil with viscosity 46 mm²/s at 40°C.

HYDRAULIC SYMBOL

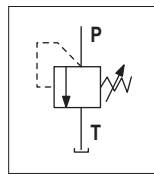

ORDERING CODE

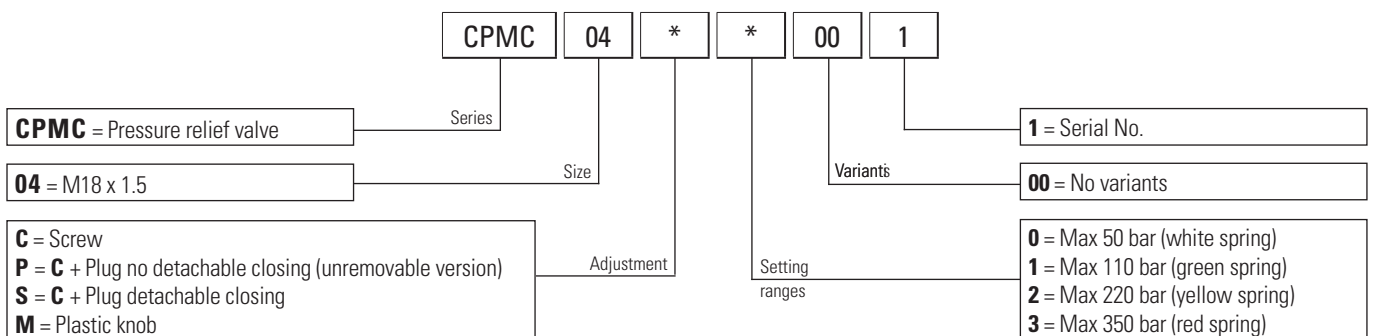

DIRECT ACTING PRESSURE RELIEF VALVES (FOR POWER PACKS SERIES MC/MS)

1

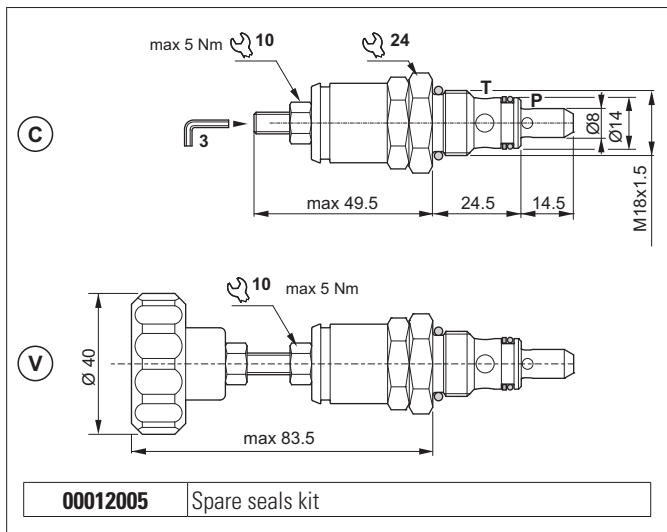

The direct acting relief valve limits the pressure in a hydraulic circuit. It raises the safety level by making it impossible for the plant operators to set a higher pressure rating, than that specified in the catalogue. It has a pack spring with a mechanical stop. It has a galvanised steel body. The guided ball poppet is in tempered and ground steel.

HYDRAULIC FEATURES

Max. working pressure	290 bar
Setting range:	
Spring 0 (white)	max 50 bar
Spring 1 (green)	max 90 bar
Spring 2 (yellow)	max 190 bar
Spring 3 (red)	max 290 bar
Max. Flow	20 l/min
Hydraulic fluid	DIN 51524 Mineral oils
Fluid viscosity	10 ÷ 500 mm ² /s
Fluid temperature	-25°C ÷ 75°C
Ambient temperature	-25°C ÷ 60°C
Max. contamin. level class with filter	ISO 4406:1999 - class 19/17/14
Weight	0,12 kg
Tightening torque	28 ÷ 32 Nm
Cavity (M18x1.5)	CN041009 (See section 17)

ACCESSORIES

Detachable plug	Code
Unremovable version 	60309200
Removable version 	60309100

The minimum permissible setting pressure depending on the spring: see curves below

HYDRAULIC SYMBOL

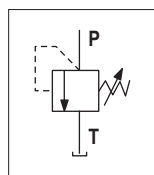

PRESSURE-FLOW RATE

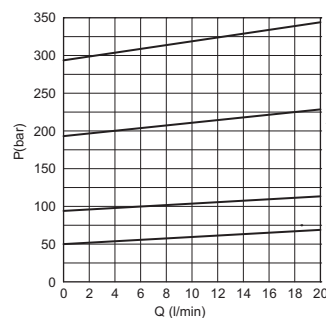

MIN. SETTING PRESSURE

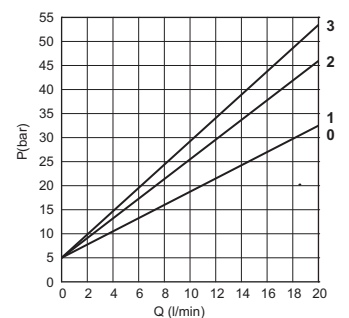

0 = 0 ÷ 50 bar - 1 = 35 ÷ 90 bar - 2 = 75 ÷ 190 bar - 3 = 160 ÷ 290 bar
 Fluid used: mineral based oil with viscosity 46 mm²/s at 40°C.

ORDERING CODE

Adjustment	Setting ranges	Code
C Screw	0 ÷ 50 bar (white spring)	21000016.000
	35 ÷ 90 bar (green spring)	21000000.000
	75 ÷ 190 bar (yellow spring)	21000001.000
	160 ÷ 290 bar (red spring)	21000002.000

Adjustment	Setting ranges	Code
V Handwheel	0 ÷ 50 bar (white spring)	21000017.000
	35 ÷ 90 bar (green spring)	21000003.000
	75 ÷ 190 bar (yellow spring)	21000004.000
	160 ÷ 290 bar (red spring)	21000005.000

DIRECT ACTING PRESSURE RELIEF VALVES

1

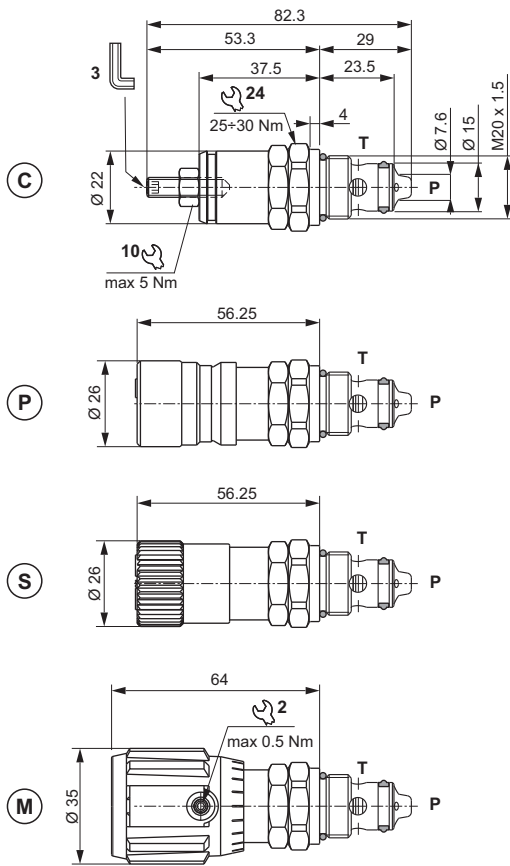

00012006 Spare seals kit

HYDRAULIC SYMBOL

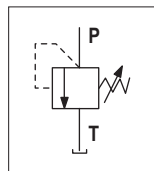

The direct acting relief valve limits the pressure in a hydraulic circuit. It raises the safety level by making it impossible for the plant operators to set a higher pressure rating, than that specified in the catalogue. This is limited by a pack spring with a mechanical stop. It has a galvanised steel body. The guided ball poppet is in tempered and ground steel.

HYDRAULIC FEATURES

Max. working pressure	350 bar
Setting range:	
Spring 0 (white)	max 50 bar
Spring 1 (green)	max 110 bar
Spring 2 (yellow)	max 220 bar
Spring 3 (red)	max 350 bar
Max. Flow	30 l/min
Hydraulic fluid	DIN 51524 Mineral oils
Fluid viscosity	10 ÷ 500 mm ² /s
Fluid temperature	-25°C ÷ 75°C
Ambient temperature	-25°C ÷ 60°C
Max. contamin. level class with filter	ISO 4406:1999 - class 19/17/14
Weight	0.16 kg
Tightening torque	30 ÷ 35 Nm
Cavity (M20 x 1.5)	CN044001 (See section 17)

The minimum permissible setting pressure depending on the spring: see curves below

PRESSURE-FLOW RATE

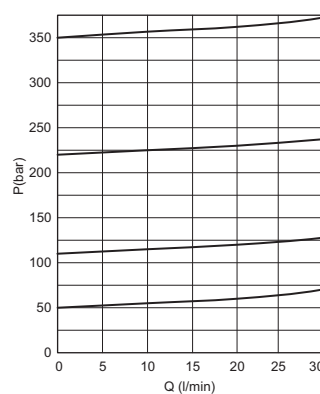

MIN.SETTING PRESSURE

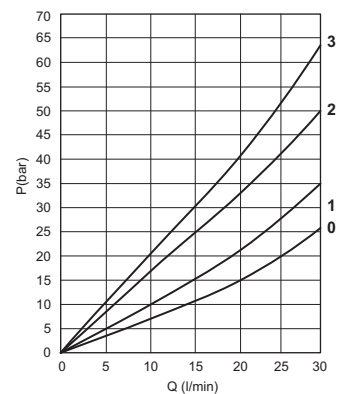

0 = CMP06*0 - 1 = CMP06*1.. - 2 = CMP06*2.. - 3 = CMP06*3..
Fluid used: mineral based oil with viscosity 46 mm²/s at 40°C.

ORDERING CODE

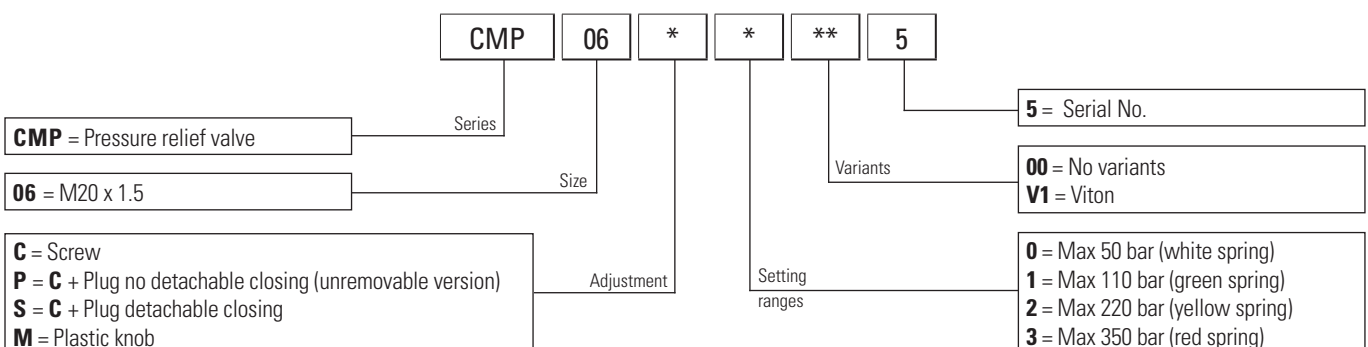

DIRECT ACTING PRESSURE RELIEF VALVES

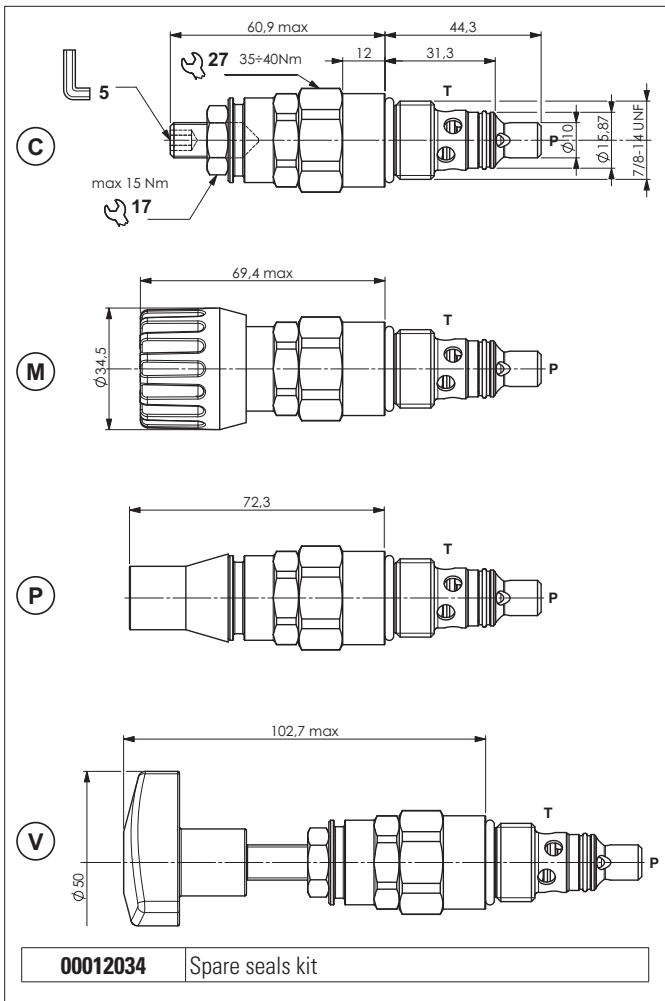

The direct acting relief valve limits the pressure in a hydraulic circuit. It raises the safety level by making it impossible for the plant operators to set a higher pressure rating, than that specified in the catalogue. This is limited by a pack spring with a mechanical stop. It has a galvanised steel body. The guided ball poppet is in tempered and ground steel.

1

HYDRAULIC FEATURES

Max. working pressure	350 bar
Setting range:	
Spring 1 (orange)	max 15 bar
Spring 1 (white)	max 50 bar
Spring 2 (yellow)	max 170 bar
Spring 3 (neutral)	70 ÷ 350 bar
Max. Flow	50 l/min
Hydraulic fluid	DIN 51524 Mineral oils
Fluid viscosity	10 ÷ 500 mm ² /s
Fluid temperature	-25°C ÷ 75°C
Ambient temperature	-25°C ÷ 60°C
Max. contamin. level class with filter	ISO 4406:1999 - class 19/17/14
Weight	0.22 kg
Tightening torque	35 ÷ 40 Nm
Cavity (7/8 - 14 UNF)	CD019011 (See section 17)

The minimum permissible setting pressure depending on the spring: see curves below

HYDRAULIC SYMBOL

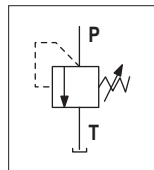

PRESSURE-FLOW RATE

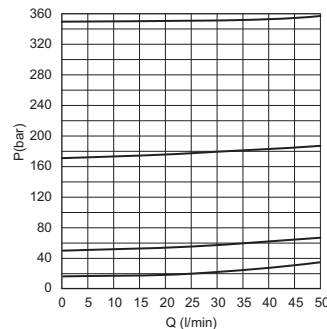

MIN. SETTING PRESSURE

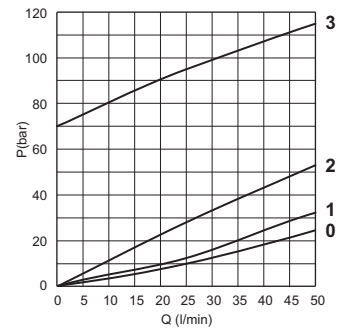

0 = CP06.0.. - 1 = CP06.1.. - 2 = CP06.2.. - 3 = CP06.3..
 Fluid used: mineral based oil with viscosity 46 mm²/s at 40°C.

ORDERING CODE

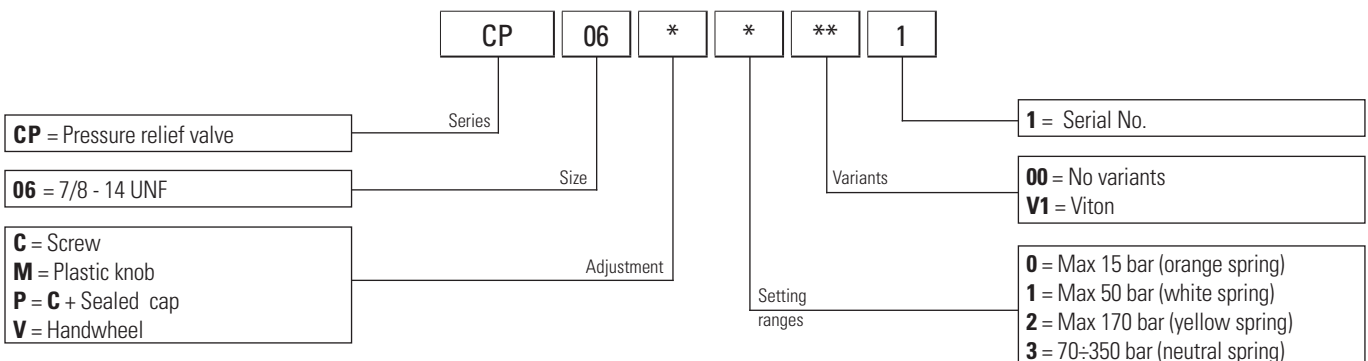

DIRECT ACTING PRESSURE RELIEF VALVES

1

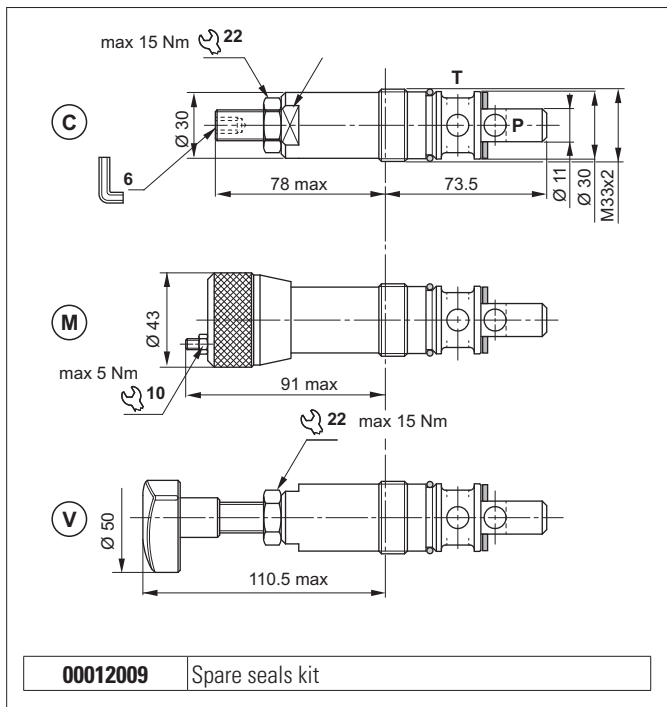

The direct acting relief valve limits the pressure in the hydraulic circuit to the calibration levels specified in the catalogue. It has a galvanised steel body. The guided ball poppet is in tempered and ground steel.

HYDRAULIC FEATURES

Max. working pressure	250 bar
Setting range:	
Spring 1 (white)	max 30 bar
Spring 2 (yellow)	max 140 bar
Spring 3 (green)	max 250 bar
Max. Flow	80 l/min
Hydraulic fluid	DIN 51524 Mineral oils
Fluid viscosity	10 ÷ 500 mm ² /s
Fluid temperature	-25°C ÷ 75°C
Ambient temperature	-25°C ÷ 60°C
Max. contamin. level class with filter	ISO 4406:1999 - class 19/17/14
Weight	0.5 kg
Tightening torque	80 ÷ 90 Nm
Cavity (M33x2)	CN070001 (See section 17)

HYDRAULIC SYMBOL

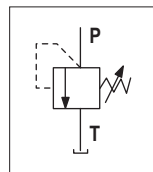

The minimum permissible setting pressure depending on the spring: see curves below

PRESSURE-FLOW RATE

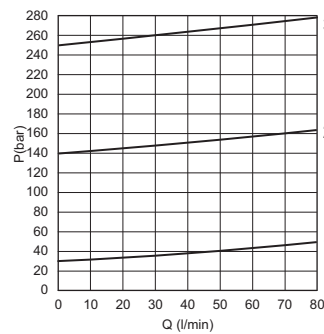

MIN. SETTING PRESSURE

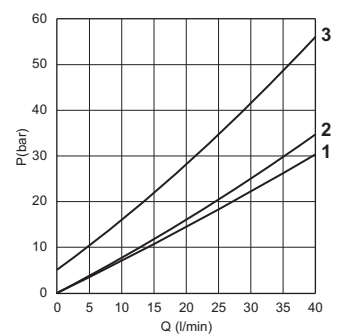

1 = CMP20.1.. - 2 = CMP20.2.. - 3 = CMP20.3..

Fluid used: mineral based oil with viscosity 46 mm²/s at 40°C.

ORDERING CODE

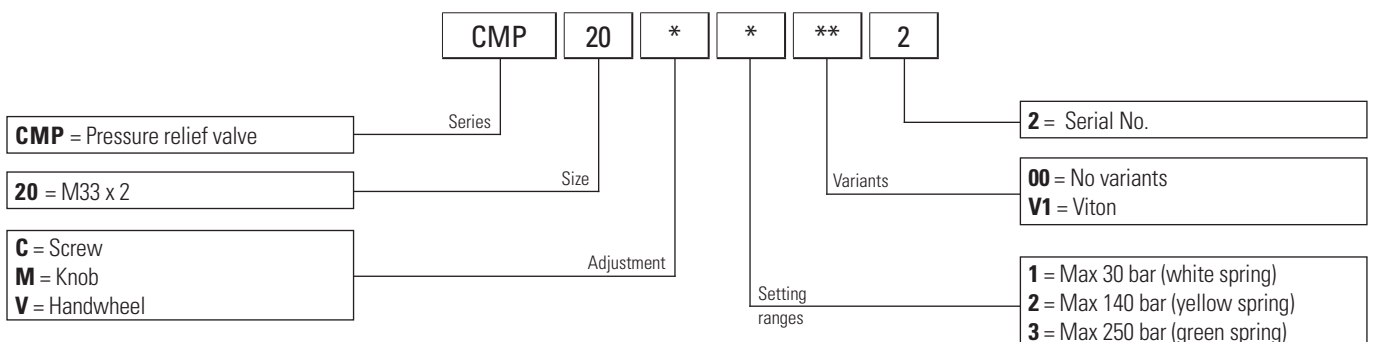

PILOT OPERATED PRESSURE RELIEF VALVES

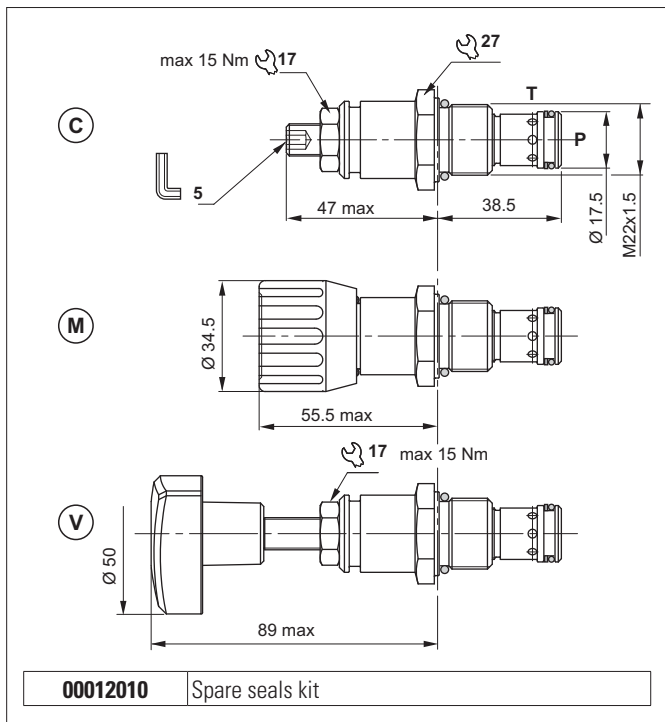

The pilot-operated relief valve limits the pressure in the hydraulic circuit. Slight leakage is tolerated for this type of valve. It raises the safety level by making it impossible for the plant operators to set a higher pressure rating, than that specified in the catalogue. It has a pack spring with a mechanical stop. It has a galvanised steel body. The tapered pilot poppet and cylindrical main plunger are made from tempered and ground steel.

HYDRAULIC FEATURES

Max. working pressure	350 bar
Setting range:	
Spring 1 (white)	max 50 bar
Spring 2 (yellow)	max 140 bar
Spring 3 (green)	max 350 bar
Max. Flow	100 l/min
Hydraulic fluid	DIN 51524 Mineral oils
Fluid viscosity	10 ÷ 500 mm ² /s
Fluid temperature	-25°C ÷ 75°C
Ambient temperature	-25°C ÷ 60°C
Max. contamin. level class with filter	ISO 4406:1999 - class 19/17/14
Weight	0.18 kg
Tightening torque	30 ÷ 40 Nm
Cavity (M22x1.5)	CN047003 (See section 17)

The minimum permissible setting pressure depending on the spring: see curves below

HYDRAULIC SYMBOL

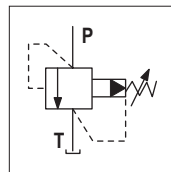

PRESSURE-FLOW RATE

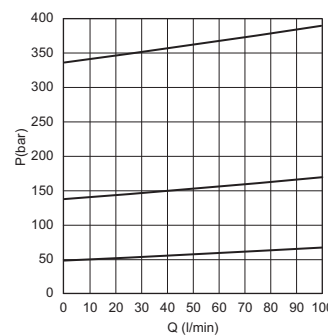

MIN.SETTING PRESSURE

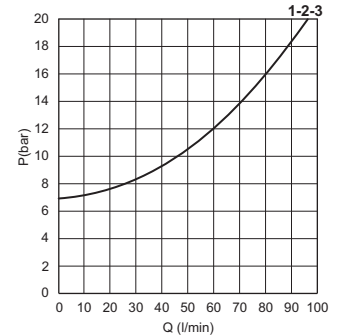

1 = CMP30.1.. - 2 = CMP30.2.. - 3 = CMP30.3..

Fluid used: mineral based oil with viscosity 46 mm²/s at 40°C.

ORDERING CODE

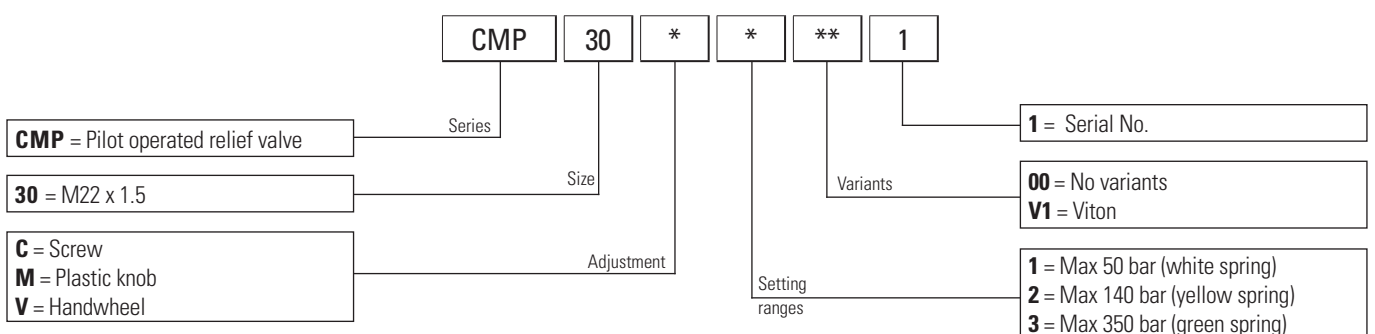

DIRECT ACTING PRESSURE RELIEF VALVES - IN-LINE MOUNTING

1

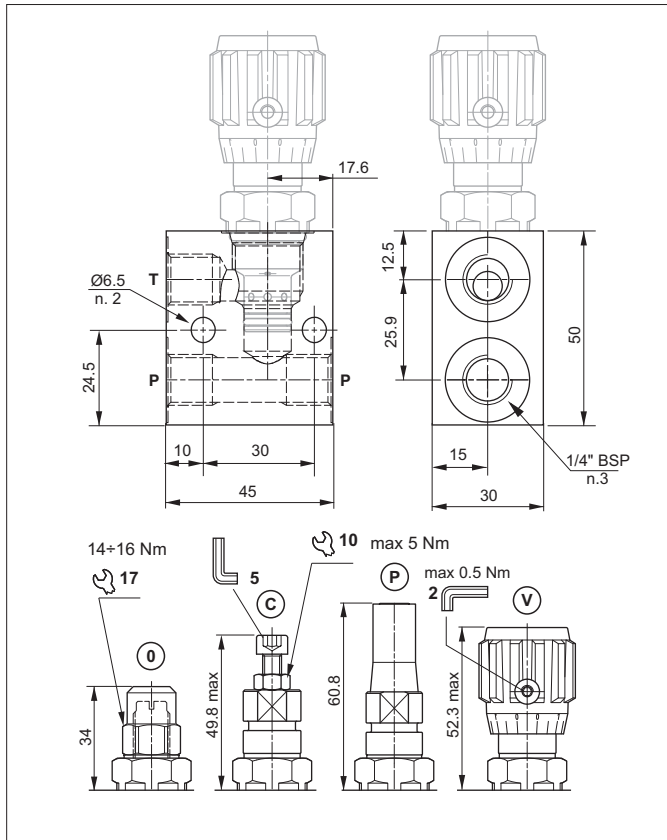

The direct acting relief valve with CMP04 cartridge limits the pressure in the hydraulic circuit
 It raises the safety level by making it impossible for the plant operators to set a higher pressure rating, than that specified in the catalogue. It has a pack spring with a mechanical stop (only standard screw and nut).
 It has a high-resistance aluminium body. The cartridge is in galvanised steel.

Max. working pressure	330 bar
Setting range:	
Spring B (white)	max 70 bar
Spring G (yellow)	max 160 bar
Spring V (green)	max 330 bar
Max. Flow	30 l/min
Hydraulic fluid	DIN 51524 Mineral oils
Fluid viscosity	10 ÷ 500 mm ² /s
Fluid temperature	-25°C ÷ 75°C
Ambient temperature	-25°C ÷ 60°C
Max. contamin. level class with filter	ISO 4406:1999 - class 19/17/14
Weight (0 version)	0.235 kg

The minimum permissible setting pressure depending on the spring: see curves below

HYDRAULIC SYMBOL

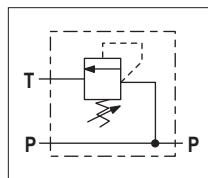

PRESSURE-FLOW RATE

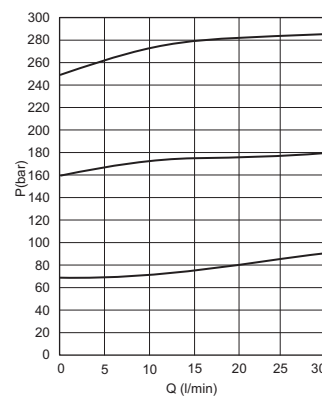

MIN.SETTING PRESSURE

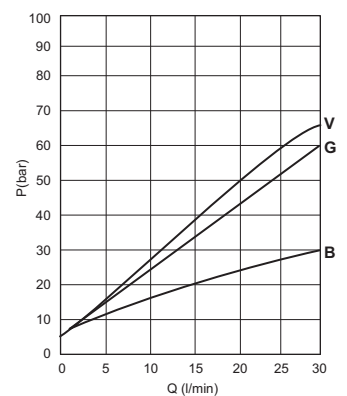

1 = VMP02*B.. - 2 = VMP02*G.. - 3 = VMP02*V..

Fluid used: mineral based oil with viscosity 32 mm²/s at 40°C.

ORDERING CODE

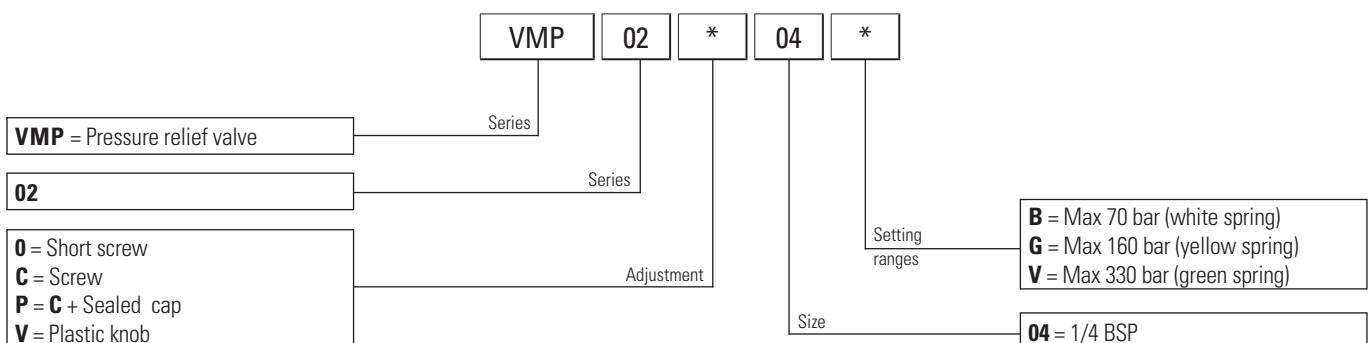

DIRECT ACTING PRESSURE RELIEF VALVES - IN-LINE MOUNTING

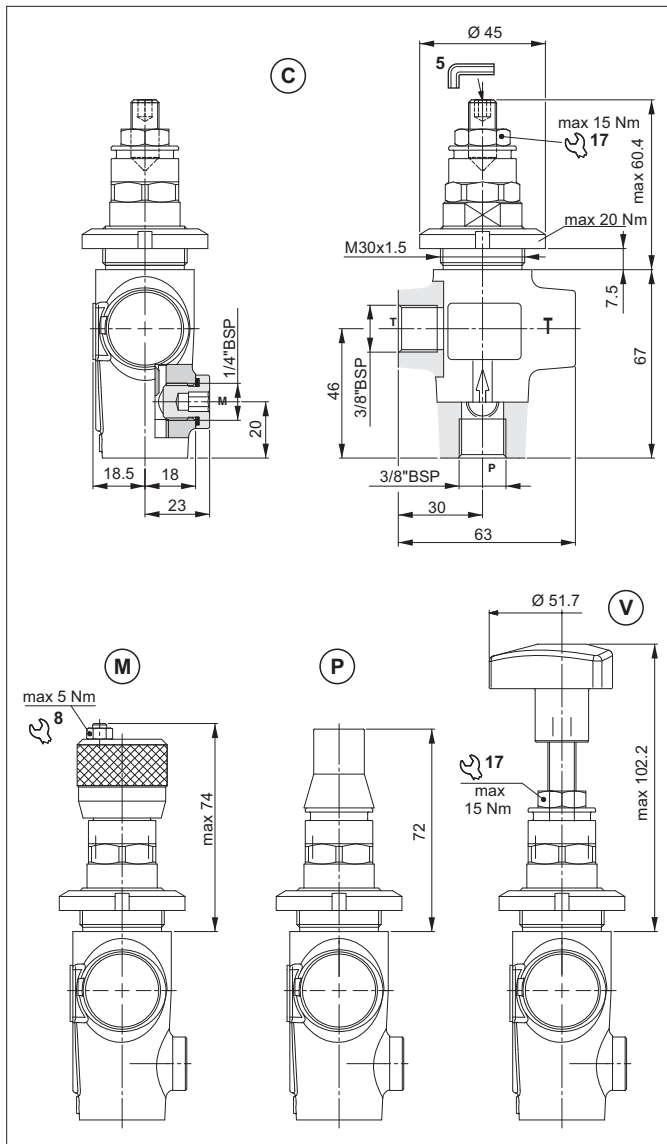

The direct acting relief valve with CP06 cartridge limits the pressure in the hydraulic circuit.

It raises the safety level by making it impossible for the plant operators to set a higher pressure rating, than that specified in the catalogue. This is limited by a pack spring with a mechanical stop.

It has a manganese phosphate coated cast iron body. The cartridge is in galvanized steel.

HYDRAULIC FEATURES

Max. working pressure	350 bar
Setting range:	
Spring 1 (orange)	max 15 bar
Spring 1 (white)	max 50 bar
Spring 2 (yellow)	max 170 bar
Spring 3 (neutral)	70 ÷ 350 bar
Max. Flow	50 l/min
Hydraulic fluid	DIN 51524 Mineral oils
Fluid viscosity	10 ÷ 500 mm ² /s
Fluid temperature	-25°C ÷ 75°C
Ambient temperature	-25°C ÷ 60°C
Max. contamin. level class with filter	ISO 4406:1999 - class 19/17/14
Weight	0.8 kg

The minimum permissible setting pressure depending on the spring: see curves below

PRESSURE-FLOW RATE

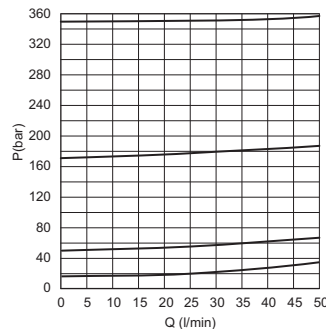

MIN. SETTING PRESSURE

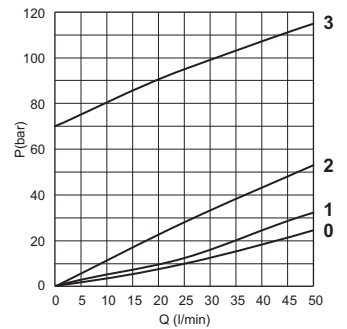

0 = VMP06.0.. - 1 = VMP06.1.. - 2 = VMP06.2.. - 3 = VMP06.3..
Fluid used: mineral based oil with viscosity 46 mm²/s at 40°C.

HYDRAULIC SYMBOL

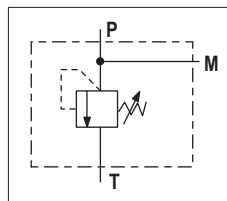

ORDERING CODE

VMP 06 * * ** 1

VMP = Pressure relief valve

Series

06 = Connector size: 3/8" BSP

Size

C = Screw
M = Plastic knob
P = C + Sealed cap
V = Handwheel

Adjustment

Variants

1 = Serial No.

00 = No variants
V1 = Viton

Setting ranges

0 = Max 15 bar (orange spring)
1 = Max 50 bar (white spring)
2 = Max 170 bar (yellow spring)
3 = 70÷350 bar (neutral spring)

DIRECT ACTING PRESSURE RELIEF VALVES - IN-LINE MOUNTING

1

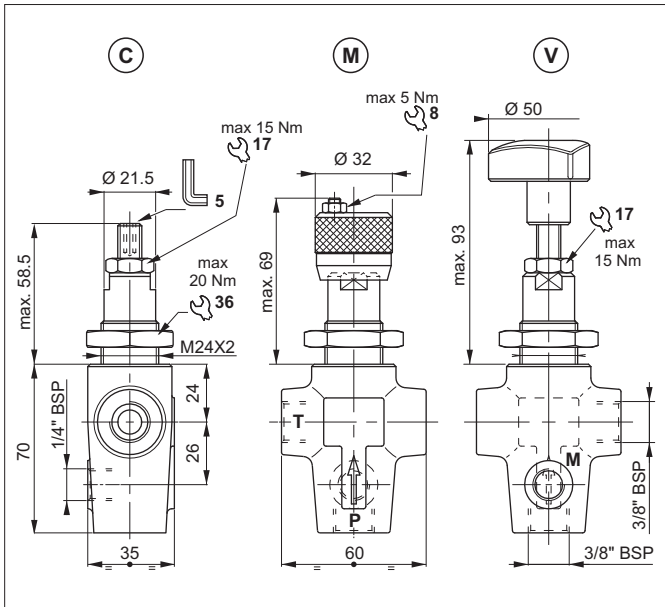

The direct acting relief valve with CMP10 cartridge limits the pressure in the hydraulic circuit.

It raises the safety level by making it impossible for the plant operators to set a higher pressure rating, than that specified in the catalogue. This is limited by a pack spring with a mechanical stop, which prevents temporary P closures caused by pressure peaks.

It has a manganese phosphate coated cast iron body. The cartridge is in galvanized steel.

HYDRAULIC FEATURES

Max. working pressure	320 bar
Setting range:	
Spring 1 (orange)	max 15 bar
Spring 1 (white)	max 50 bar
Spring 2 (yellow)	max 150 bar
Spring 3 (green)	max 320 bar
Max. Flow	40 l/min
Hydraulic fluid	DIN 51524 Mineral oils
Fluid viscosity	10 ÷ 500 mm ² /s
Fluid temperature	-25°C ÷ 75°C
Ambient temperature	-25°C ÷ 60°C
Max. contamin. level class with filter	ISO 4406:1999 - class 19/17/14
Weight	0.8 kg

HYDRAULIC SYMBOL

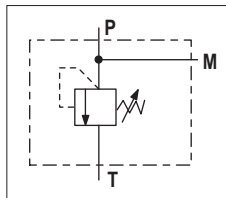

PRESSURE-FLOW RATE

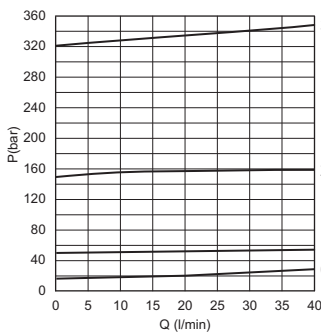

MIN.SETTING PRESSURE

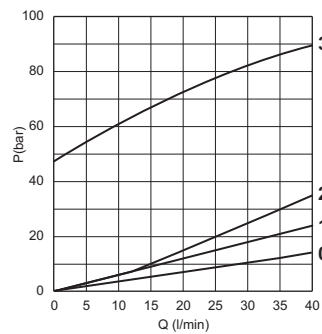

0 = VMP10.0.. - 1 = VMP10.1.. - 2 = VMP10.2.. - 3 = VMP10.3..

Fluid used: mineral based oil with viscosity 46 mm²/s at 40°C.

The minimum permissible setting pressure depending on the spring: see curves.

ORDERING CODE

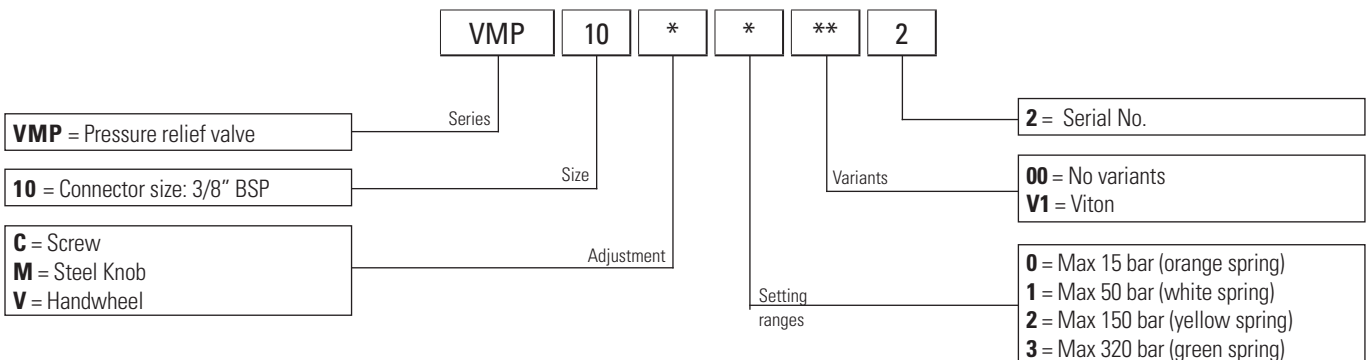

DIRECT ACTING PRESSURE RELIEF VALVES - IN-LINE MOUNTING

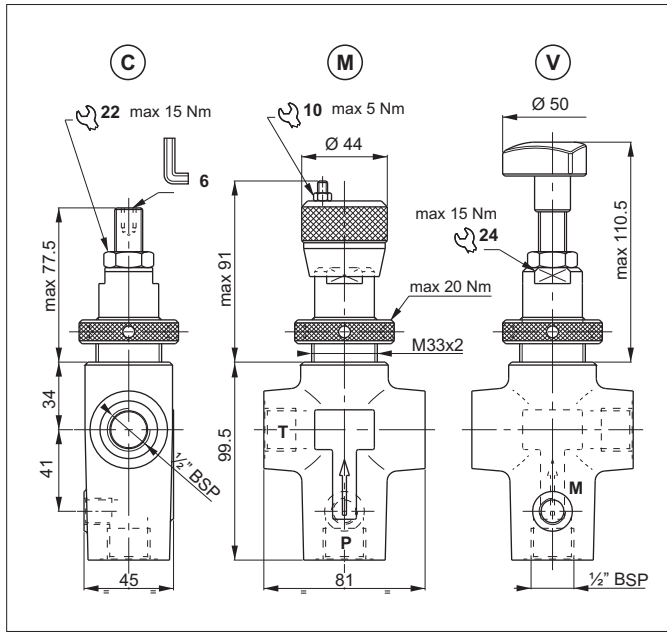

The direct acting relief valve with CMP20 cartridge limits the pressure in the hydraulic circuit to the calibration field specified in the catalogue. It has a manganese phosphate coated cast iron body. The cartridge is in galvanized steel.

1

HYDRAULIC SYMBOL

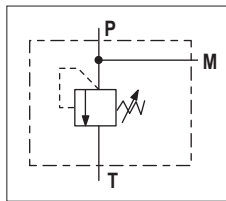

HYDRAULIC FEATURES

Max. working pressure	250 bar
Setting range:	
Spring 1 (white)	max 30 bar
Spring 2 (yellow)	max 140 bar
Spring 3 (green)	max 250 bar
Max. Flow	80 l/min
Hydraulic fluid	DIN 51524 Mineral oils
Fluid viscosity	10 ÷ 500 mm ² /s
Fluid temperature	-25°C ÷ 75°C
Ambient temperature	-25°C ÷ 60°C
Max. contamin. level class with filter	ISO 4406:1999 - class 19/17/14
Weight	1.7 kg

PRESSURE-FLOW RATE

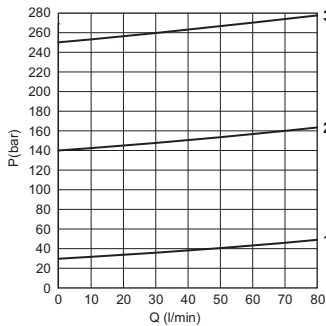

MIN.SETTING PRESSURE

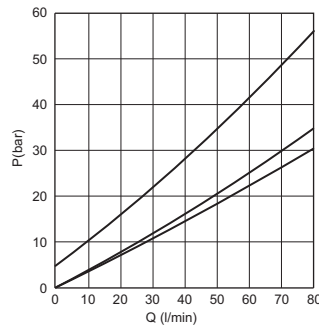

1 = VMP20.1.. - 2 = VMP20.2.. - 3 = VMP20.3..

Fluid used: mineral based oil with viscosity 46 mm²/s at 40°C.

The minimum permissible setting pressure depending on the spring: see curves.

ORDERING CODE

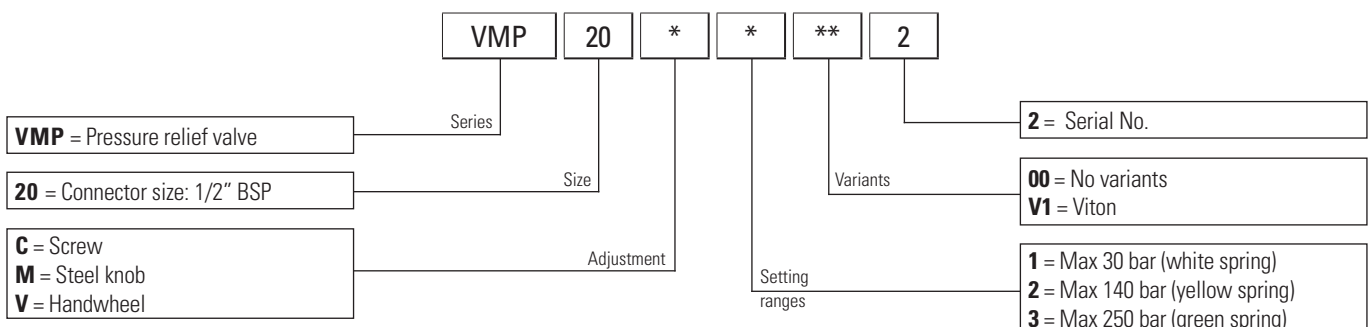

PILOT OPERATED PRESSURE RELIEF VALVES - IN-LINE MOUNTING

1

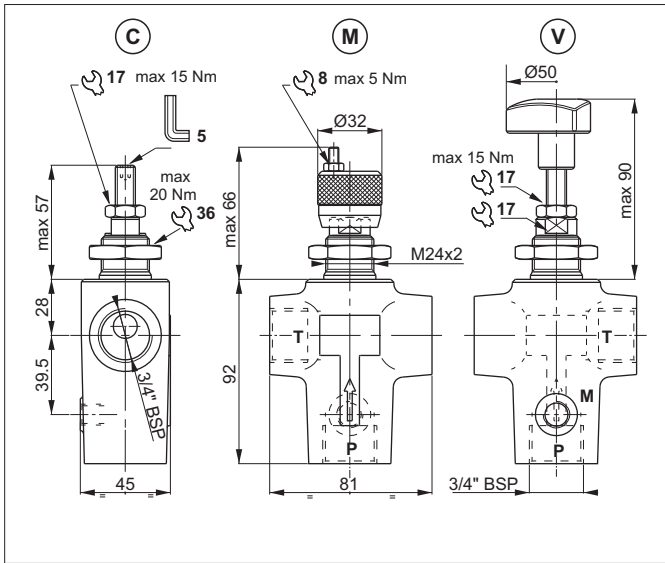

The direct acting relief valve with CMP30 cartridge limits the pressure in the hydraulic circuit.

Slight leakage is tolerated for this type of valve.

It raises the safety level by making it impossible for the plant operators to set a higher pressure rating, than that specified in the catalogue. It has a pack spring with a mechanical stop.

It has a manganese phosphate coated cast iron body. The cartridge is in galvanized steel.

HYDRAULIC SYMBOL

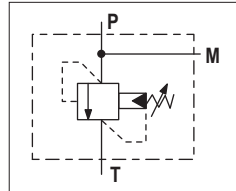

HYDRAULIC FEATURES

Max. working pressure	350 bar
Setting range:	
Spring 1 (white)	max 50 bar
Spring 2 (yellow)	max 140 bar
Spring 3 (green)	max 350 bar
Max. Flow	100 l/min
Hydraulic fluid	DIN 51524 Mineral oils
Fluid viscosity	10 ÷ 500 mm ² /s
Fluid temperature	-25°C ÷ 75°C
Ambient temperature	-25°C ÷ 60°C
Max. contamin. level class with filter	ISO 4406:1999 - class 19/17/14
Weight	1.4 kg

PRESSURE-FLOW RATE

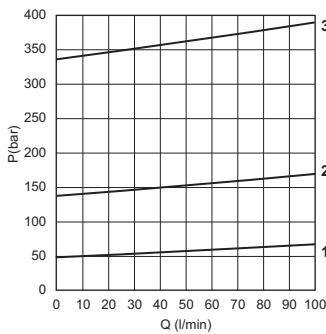

MIN.SETTING PRESSURE

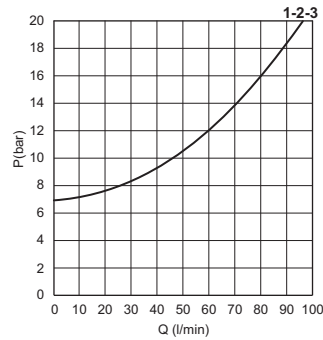

The minimum permissible setting pressure depending on the spring: see curves.

1 = VMP30.1.. - 2 = VMP30.2.. - 3 = VMP30.3..

Fluid used: mineral based oil with viscosity 46 mm²/s at 40°C.

ORDERING CODE

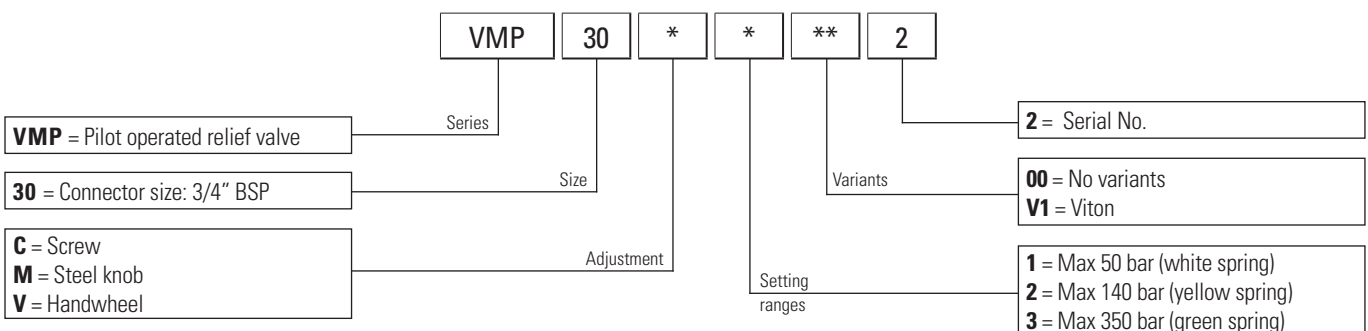

PILOT OPERATED PRESSURE RELIEF VALVES - IN-LINE MOUNTING

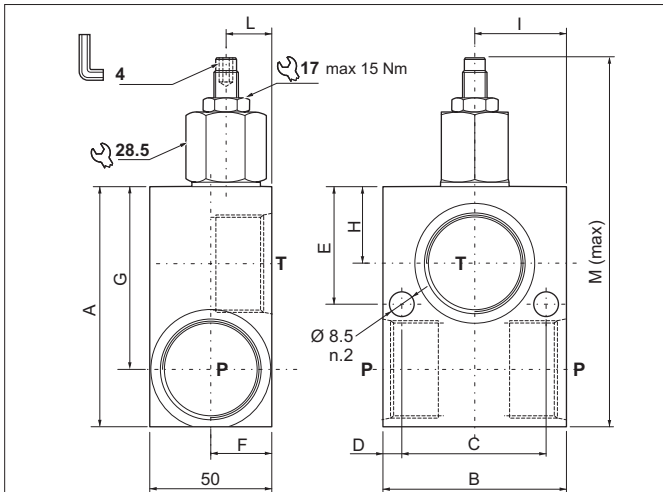

CODE	P - T Attacchi/Ports	A	B	C	D	E	F	G	H	I	L	M
VMP12012	3/4" BSP	92	50	37	6	12.5	31	71.5	35	25	31	145.4
VMP12016	1" BSP	100	77	60	8.5	49	25	76	32	38	17	154

The pilot-operated relief valve limits the pressure in the hydraulic circuit. Slight leakage is tolerated for this type of valve. It raises the safety level by making it impossible for the plant operators to set a higher pressure rating, than that specified in the catalogue. It has a pack spring with a mechanical stop. It has a high-resistance aluminium body. The cartridge is in galvanised steel.

1

HYDRAULIC SYMBOL

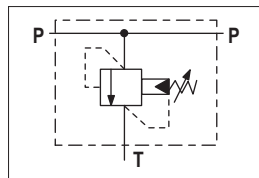

HYDRAULIC FEATURES

Max. working pressure	350 bar
Max. Flow	150 l/min
Hydraulic fluid	DIN 51524 Mineral oils
Fluid viscosity	10 ÷ 500 mm ² /s
Fluid temperature	-25°C ÷ 75°C
Ambient temperature	-25°C ÷ 60°C
Max. contamin. level class with filter	ISO 4406:1999 - class 19/17/14
Weight	0.65 kg (3/4 BSP) 0.91 kg (1 BSP)
Cavity	(1" - 14 UNS) - Ø 19.05 mm

PRESSURE-FLOW RATE

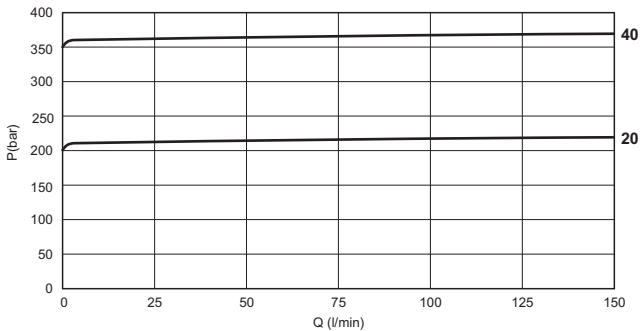

Fluid used: mineral based oil with viscosity 24 mm²/s at 50°C.

ORDERING CODE

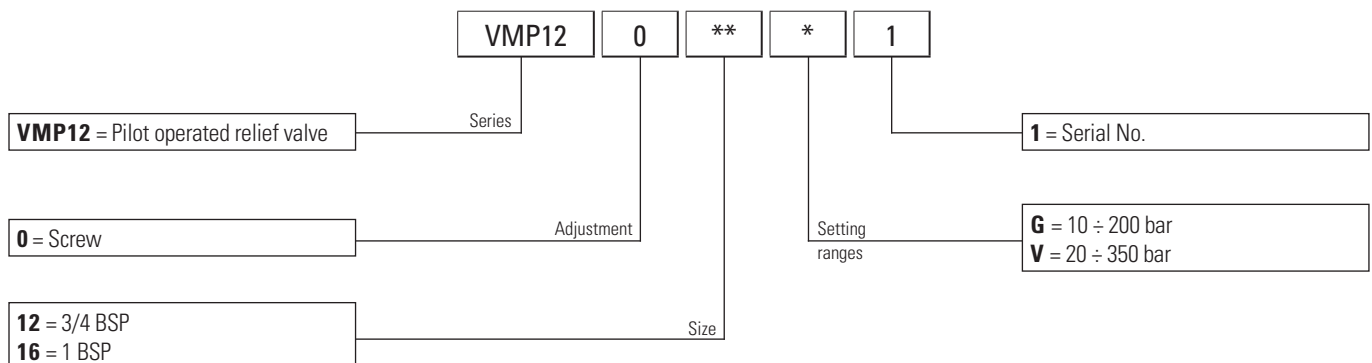

SEQUENCE, PRESSURE REDUCING AND UNLOADING VALVES

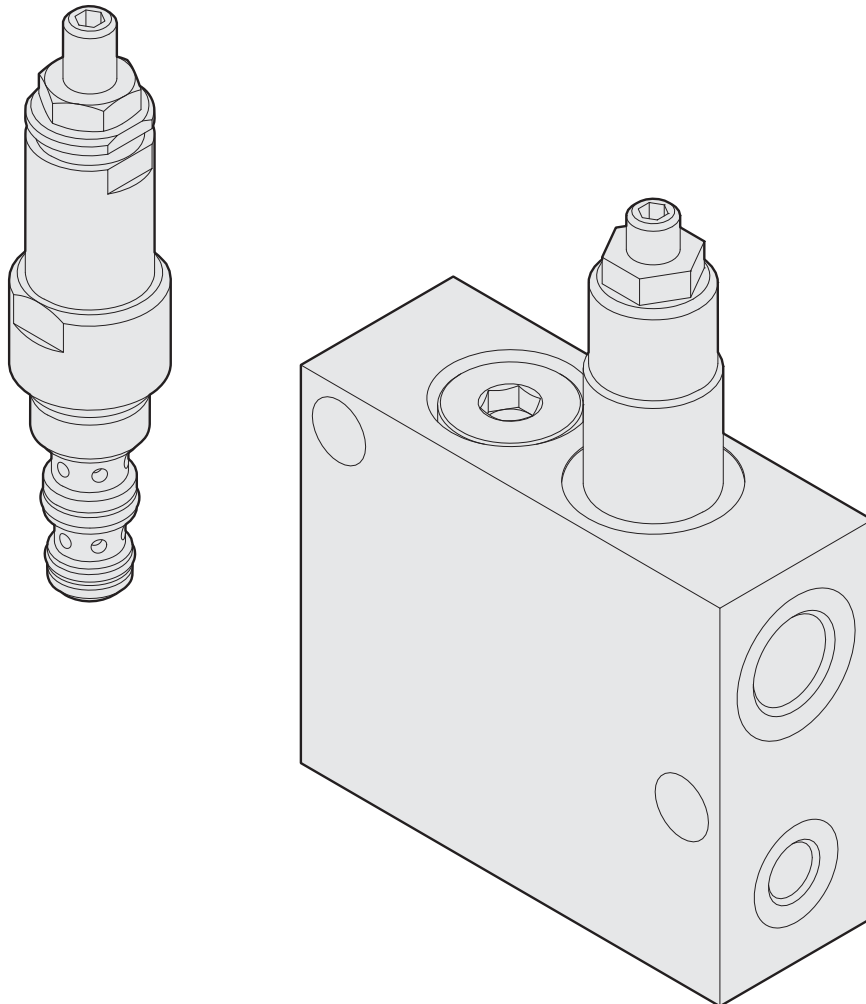

SEQUENCE VALVES - DIRECTLY OPERATED

2

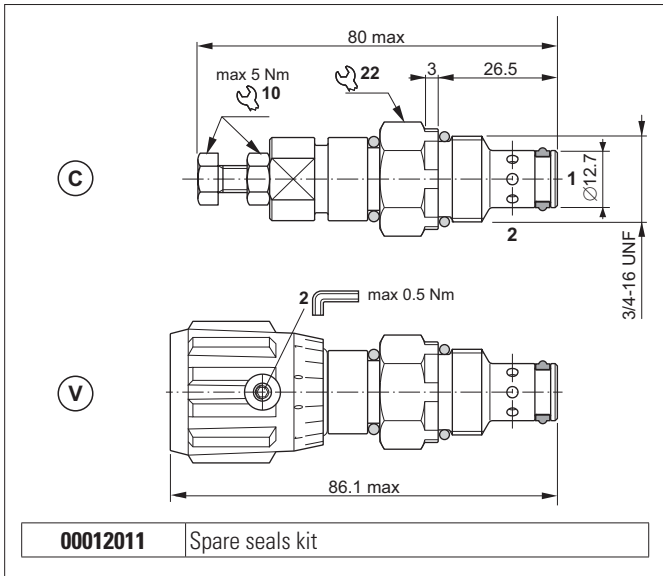

The direct acting sequence valve feeds a secondary branch of a circuit when a set pressure value is reached and suppresses the primary pressure. It raises the safety level by making it impossible for the plant operators to set a higher pressure rating, than that specified in the catalogue. It has a pack spring with a mechanical stop (only standard screw and nut). It has a galvanized steel body. The guided ball poppet is in tempered and ground steel.

HYDRAULIC SYMBOL

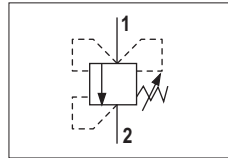

HYDRAULIC FEATURES

Max. working pressure	350 bar
Setting range:	
Spring 1 (white)	max 70 bar
Spring 2 (yellow)	max 180 bar
Spring 3 (green)	max 340 bar
Max. Flow	30 l/min
Hydraulic fluid	DIN 51524 Mineral oils
Fluid viscosity	10 ÷ 500 mm ² /s
Fluid temperature	-25°C ÷ 75°C
Ambient temperature	-25°C ÷ 60°C
Max. contamin. level class with filter	ISO 4406:1999 - class 19/17/14
Weight	CSQ04C: 0.115 kg CSQ04V: 0.150 kg
Tightening torque	25 ÷ 30 Nm
Cavity (3/4 - 16 UNF)	CD018006 (See section 17)

PRESSURE-FLOW RATE

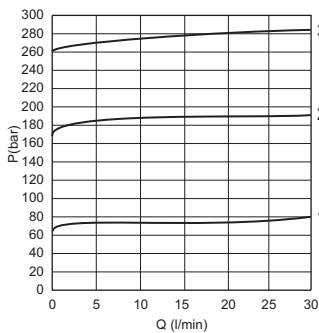

MIN. SETTING PRESSURE

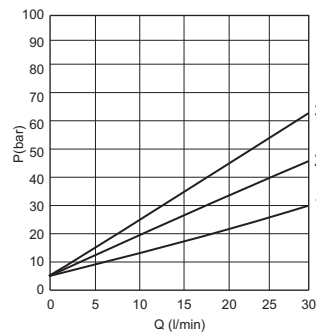

1 = CSQ04.1.. - 2 = CSQ04.2.. - 3 = CSQ04.3..
Fluid used: mineral based oil with viscosity 32 mm²/s at 40°C.

The minimum permissible setting pressure depending on the spring: see curves below

ORDERING CODE

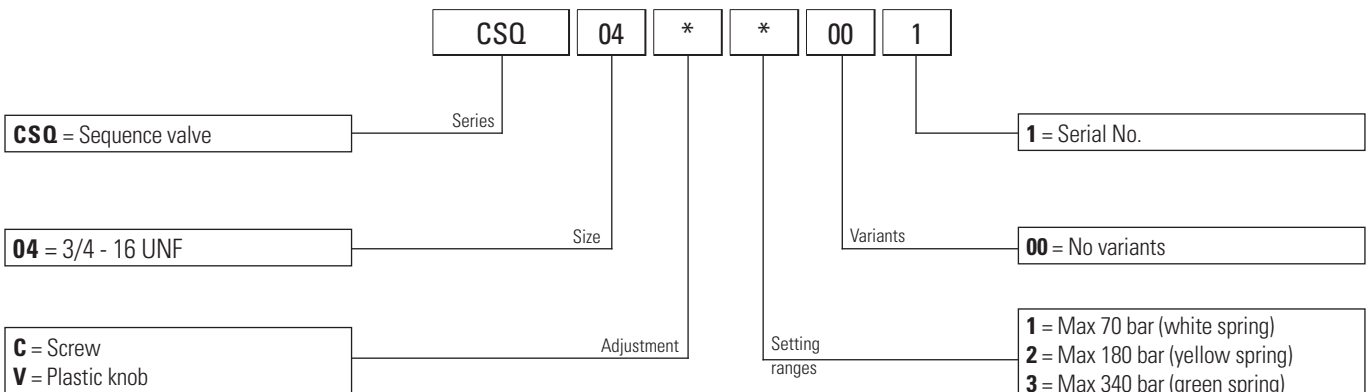

SEQUENCE VALVES - DIRECTLY OPERATED (FOR MK3 SERIES POWER PACKS)

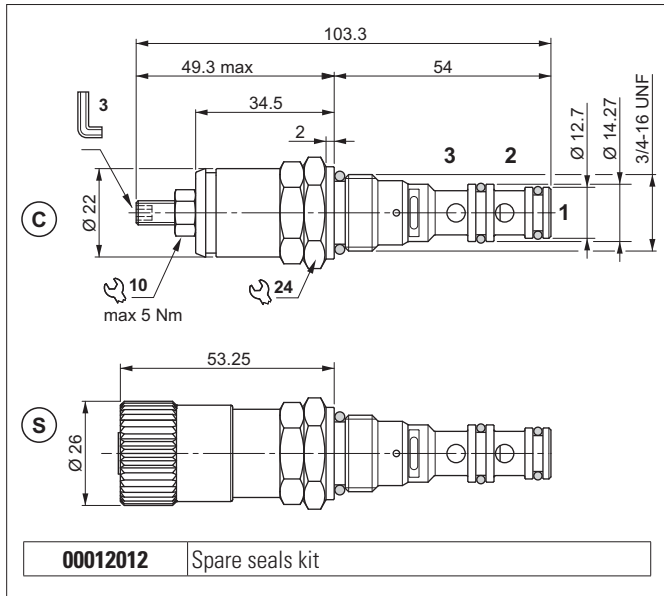

3 way direct acting sequence valve feeds with 1 → 2 flow, a secondary branch of a circuit when a set pressure value is reached. While the port 3 is normally connected to tank. When the port 1 is at a lower pressure than the setting pressure, the ports 2 and 3 are connected to tank. Back pressure on port 3 adds to the valve setting. Back pressure on port 2 does not effect the valve setting when there is flow from port 1 to 2. It raises the safety level by making it impossible for the plant operators to set a higher pressure rating, than that specified in the catalogue. It has a pack spring with a mechanical stop (only standard screw and nut). The body is made of steel with nitrocarburizing treatment while the spool is made of tempered and ground steel.

2

HYDRAULIC FEATURES

Max. pressure	210 bar
Setting range:	
Spring 1 (neutral)	max 125 bar
Spring 2 (yellow)	max 160 bar
Max. Flow	10 l/min
Leakage at 70% of the spring calibration (flow 1 l/min)	
Spring 1: 0 ÷ 30 drops/min	Spring 1: 0 ÷ 1.5 cm ³ /min
Spring 2: 0 ÷ 60 drops/min	Spring 2: 0 ÷ 3 cm ³ /min
Hydraulic fluid	DIN 51524 Mineral oils
Fluid viscosity	10 ÷ 500 mm ² /s
Fluid temperature	-25°C ÷ 75°C
Ambient temperature	-25°C ÷ 60°C
Max. contamin. level class with filter	ISO 4406:1999 - class 19/17/14
Weight	CSMK04C.. : 0.145 kg CSMK04S.. : 0.152 kg
Tightening torque	25 ÷ 30 Nm
Cavity (3/4 - 16 UNF)	CDD18001 (See section 17)

The minimum permissible setting pressure depending on the spring: see curves.

HYDRAULIC SYMBOL

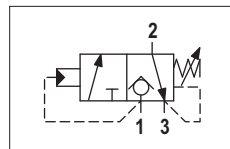

PRESSURE-FLOW RATE (1 → 2)

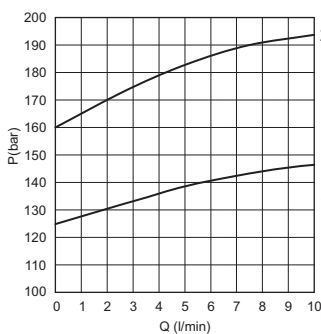

MIN.SETTING PRESSURE (1 → 2)

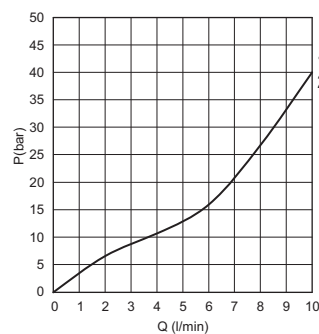

PRESSURE DROPS (2 → 3)

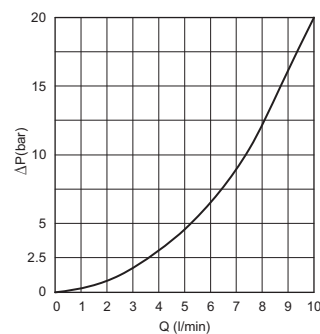

1 = CSMK04.1..
2 = CSMK04.2..

Fluid used: mineral based oil with viscosity 46 mm²/s at 40°C.

ORDERING CODE

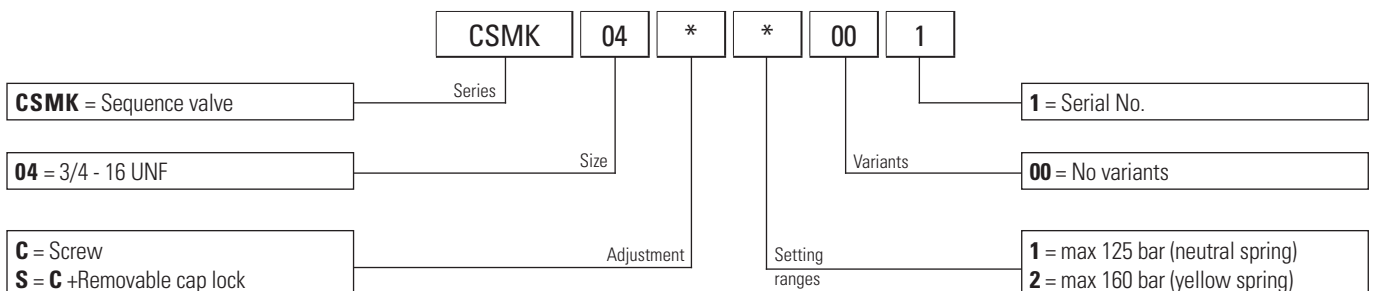

SEQUENCE VALVES - PILOT OPERATED

2

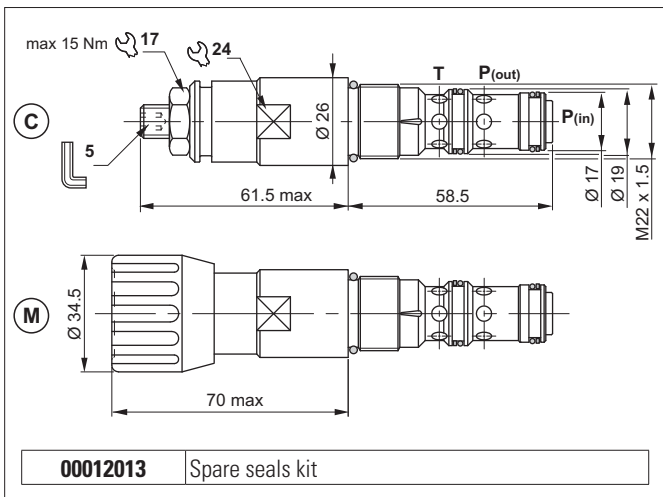

The pilot-operated sequence valve feeds a secondary branch of a circuit when a set pressure value is reached, guaranteeing minimum variation of the set pressure with flow alterations of up to 90 l/min. Slight leakage is tolerated for this type of valve. It raises the safety level by making it impossible for the plant operators to set a higher pressure rating, than that specified in the catalogue. It has a pack spring with a mechanical stop. It has a galvanised steel body. The guided ball pilot poppet and cylindrical main plunger are made from tempered and ground steel.

HYDRAULIC FEATURES

Max. pressure	350 bar
Setting range:	
Spring 1 (white)	max 60 bar
Spring 2 (yellow)	max 120 bar
Spring 3 (green)	max 250 bar
Max. Flow	90 l/min
Max. draining on port T	0.5 ÷ 0.7 l/min
Hydraulic fluid	DIN 51524 Mineral oils
Fluid viscosity	10 ÷ 500 mm ² /s
Fluid temperature	-25°C ÷ 75°C
Ambient temperature	-25°C ÷ 60°C
Max. contamin. level class with filter	ISO 4406:1999 - class 19/17/14
Weight	0.25 kg
Tightening torque	30 ÷ 40 Nm
Cavity (M22 x 1.5)	CN047002 (See section 17)

HYDRAULIC SYMBOL

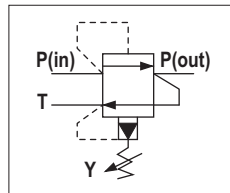

MIN. SETTING PRESSURE

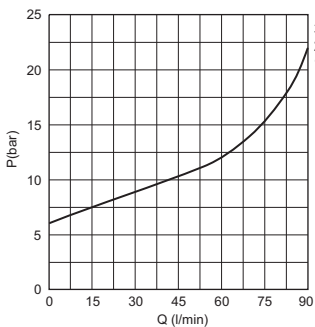

PRESSURE-FLOW RATE

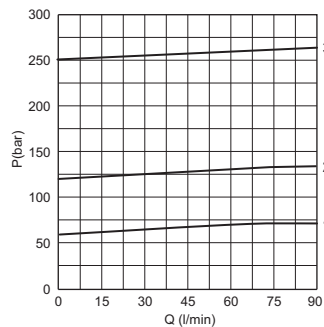

1 = CVS20.1.. - 2 = CVS20.2.. - 3 = CVS20.3..

Fluid used: mineral based oil with viscosity 46 mm²/s at 40°C.

The minimum permissible setting pressure depending on the spring: see curves.

ORDERING CODE

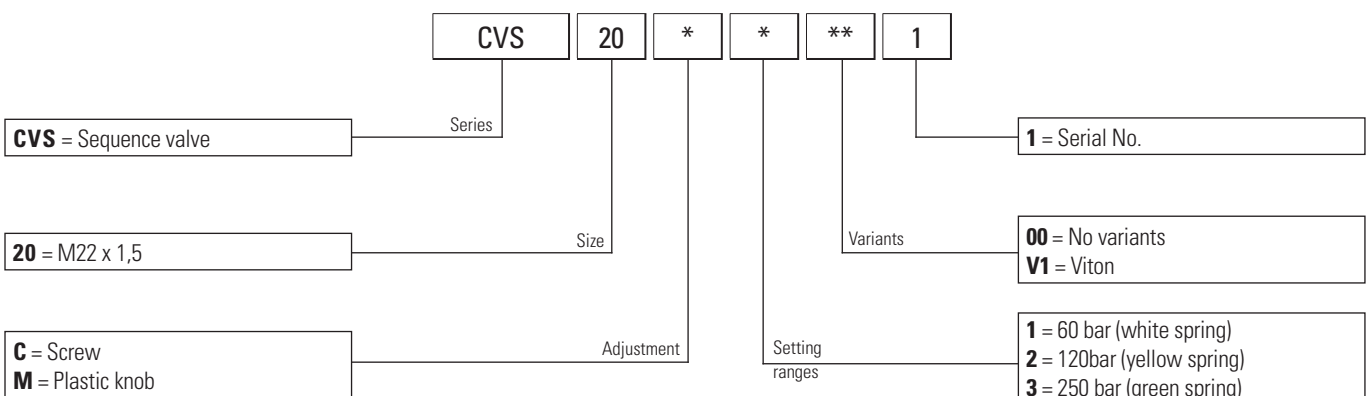

PRESSURE REDUCING VALVES WITH RELIEVING - DIRECT OPERATED

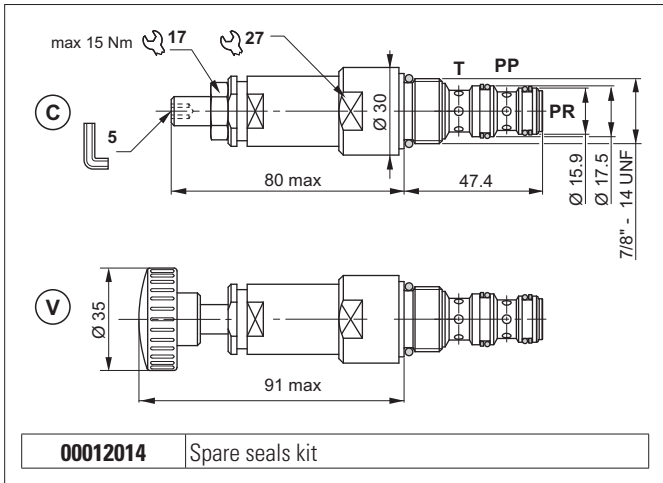

The direct acting pressure reducing valve feeds a secondary branch of a circuit at a lower pressure than the main branch, guaranteeing minimum variation of the set pressure with flow alterations of up to 20 l/min.

Slight leakage is tolerated for this type of valve.

It raises the safety level with the RELIEVING system that enables fluid to pass through the valve from PR to T, preventing pressure increases in the controlled branch and protecting the load, and by making it impossible for plant operators to set a higher pressure rating than that specified in the catalogue. It has a pack spring with mechanical stop.

It has a galvanised steel body. The plunger is in tempered and ground steel.

2

HYDRAULIC FEATURES

Max. pressure	320 bar
Setting range:	
Spring 1 (white)	max 2 ÷ 30 bar
Spring 2 (yellow)	max 6 ÷ 70 bar
Spring 3 (green)	max 35 ÷ 130 bar
Spring 4 (blue)	max 65 ÷ 230 bar
Max. Flow	20 l/min
Max. draining on port T	0.2 l/min
Hydraulic fluid	DIN 51524 Mineral oils
Fluid viscosity	10 ÷ 500 mm ² /s
Fluid temperature	-25°C ÷ 75°C
Ambient temperature	-25°C ÷ 60°C
Max. contamin. level class with filter	ISO 4406:1999 - class 19/17/14
Weight	0.3 kg
Tightening torque	35 ÷ 40 Nm
Cavity (7/8 - 14 UNF)	CD019006 (See section 17)

HYDRAULIC SYMBOL

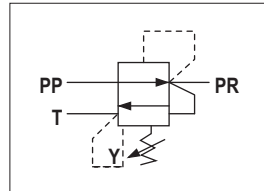

The minimum permissible setting pressure depending on the spring: see curves.

PRESSURE-FLOW OF RELIEVING

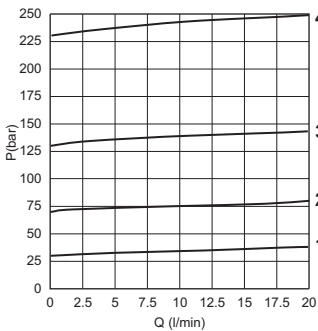

MIN.SETTING PRESSURE

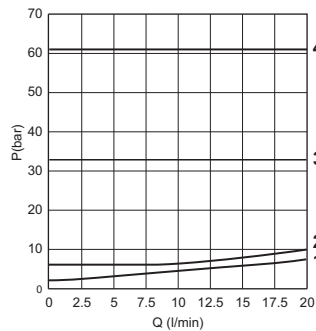

PRESSURE-FLOW RATE

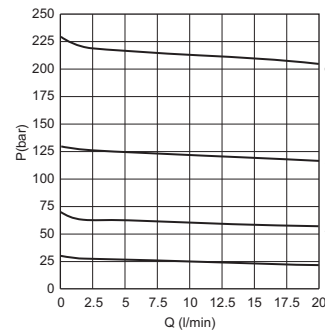

- 1 = CVR06.1..
- 2 = CVR06.2..
- 3 = CVR06.3..
- 4 = CVR06.4..

Fluid used: mineral based oil with viscosity 46 mm²/s at 40°C.

ORDERING CODE

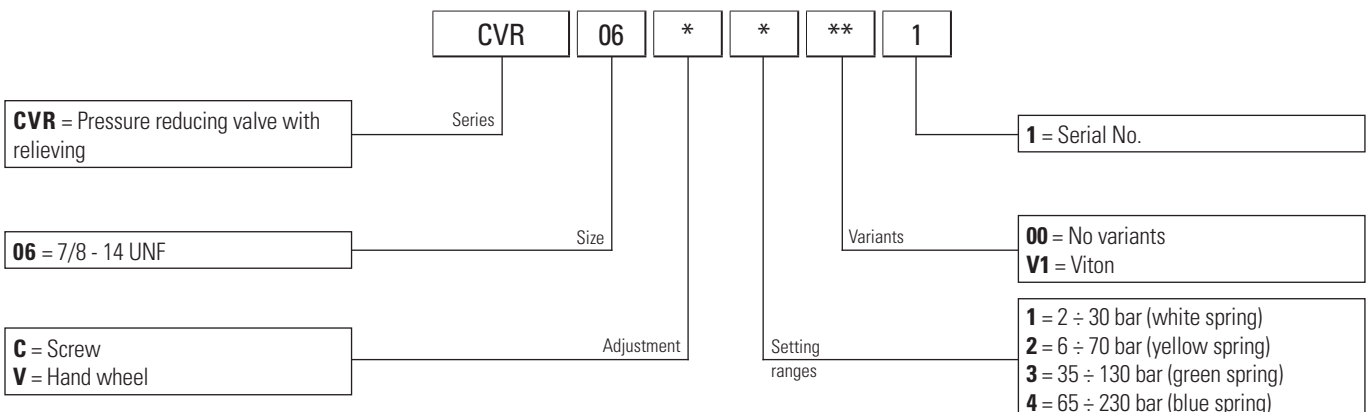

PRESSURE REDUCING VALVES WITH RELIEVING - PILOT OPERATED

2

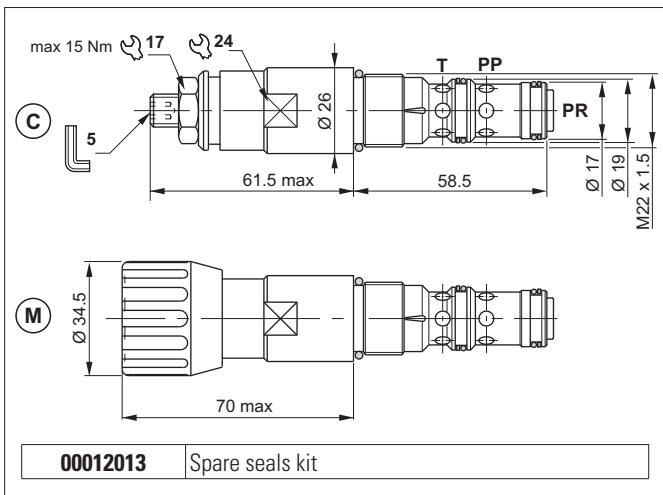

The pilot-operated pressure reducing valve feeds a secondary branch of a circuit at a lower pressure, guaranteeing minimum variation of the set pressure with flow alterations of up to 90 l/min. Slight leakage is tolerated for this type of valve.

It raises the safety level with the RELIEVING system that enables fluid to pass through the valve from PR to T, preventing pressure increases in the controlled branch and protecting the load, and by making it impossible for plant operators to set a higher pressure rating than that specified in the catalogue. It has a pack spring with mechanical stop. It has a galvanised steel body. The plunger is in tempered and ground steel.

HYDRAULIC FEATURES

Max. pressure	350 bar
Setting range:	
Spring 1 (white)	max 60 bar
Spring 2 (yellow)	max 120 bar
Spring 3 (green)	max 250 bar
Maximum allowed Δp pressure between the inlet an outlet pressure	150 bar
Max. Flow	90 l/min
Max. draining on port T	0.5 ÷ 0.7 l/min
Hydraulic fluid	DIN 51524 Mineral oils
Fluid viscosity	10 ÷ 500 mm ² /s
Fluid temperature	-25°C ÷ 75°C
Ambient temperature	-25°C ÷ 60°C
Max. contamin. level class with filter	ISO 4406:1999 - class 19/17/14
Weight	0.25 kg
Tightening torque	30 ÷ 40 Nm
Cavity (M22 x 1.5)	CN047002 (See section 17)

HYDRAULIC SYMBOL

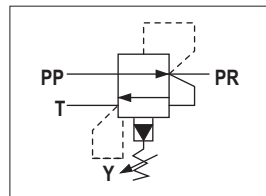

The minimum permissible setting pressure depending on the spring: see curves.

PRESSURE-FLOW OF RELIEVING

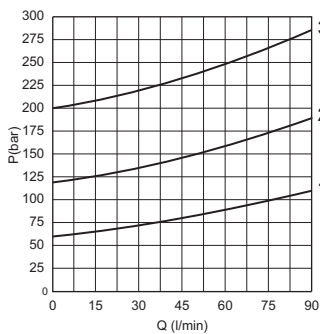

MIN. SETTING PRESSURE

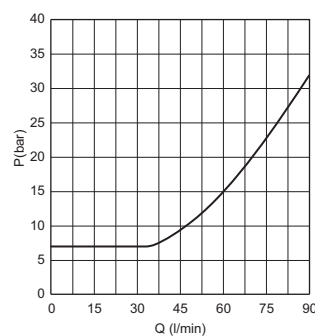

PRESSURE-FLOW RATE

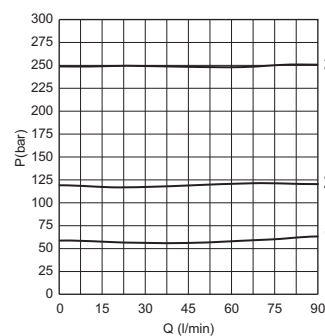

1 = CVR20.1..
2 = CVR20.2..
3 = CVR20.3..
Fluid used: mineral based oil with viscosity 46 mm²/s at 40°C.

ORDERING CODE

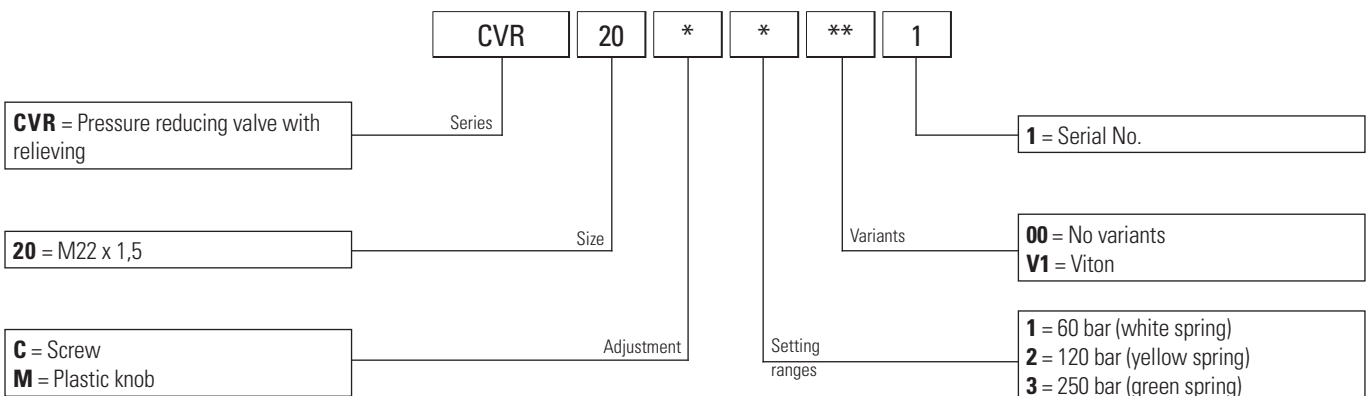

SEQUENCE VALVES

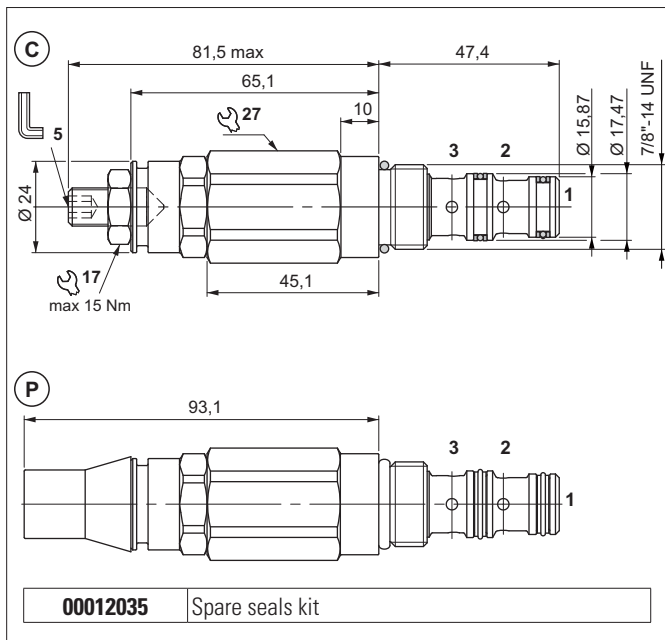

The 3-way sequence valve connects a pressurised branch to drain line when the pilot branch calibration setting is reached (port 1). Slight leakage is tolerated for this type of valve. It has a galvanised steel body. The plunger is in tempered and ground steel.

2

HYDRAULIC FEATURES

Max. pressure	400 bar
Max. Flow	30 l/min
Hydraulic fluid	DIN 51524 Mineral oils
Fluid viscosity	10 ÷ 500 mm ² /s
Fluid temperature	-25°C ÷ 75°C
Ambient temperature	-25°C ÷ 60°C
Max. contamin. level class with filter	ISO 4406:1999 - class 19/17/14
Weight	0.3 kg
Tightening torque	30 ÷ 40 Nm
Cavity (7/8 - 14 UNF)	CD019006 (See section 17)

HYDRAULIC SYMBOL

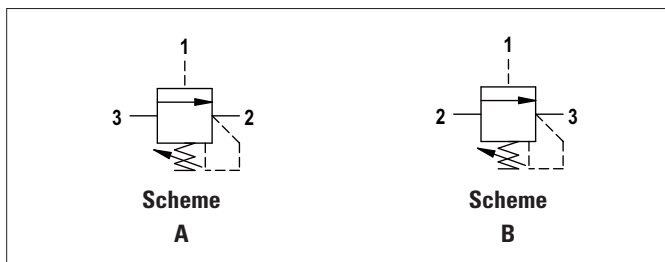

PRESSURE DROPS

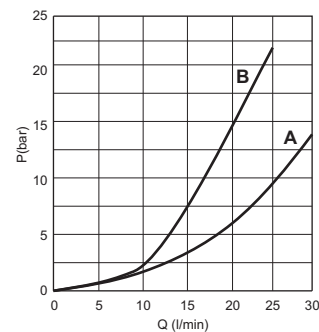

Fluid used: mineral based oil with viscosity 46 mm²/s at 40°C.

Spool scheme	Connections	Flow max l/min
A	3 → 2	30
B	2 → 3	25

ORDERING CODE

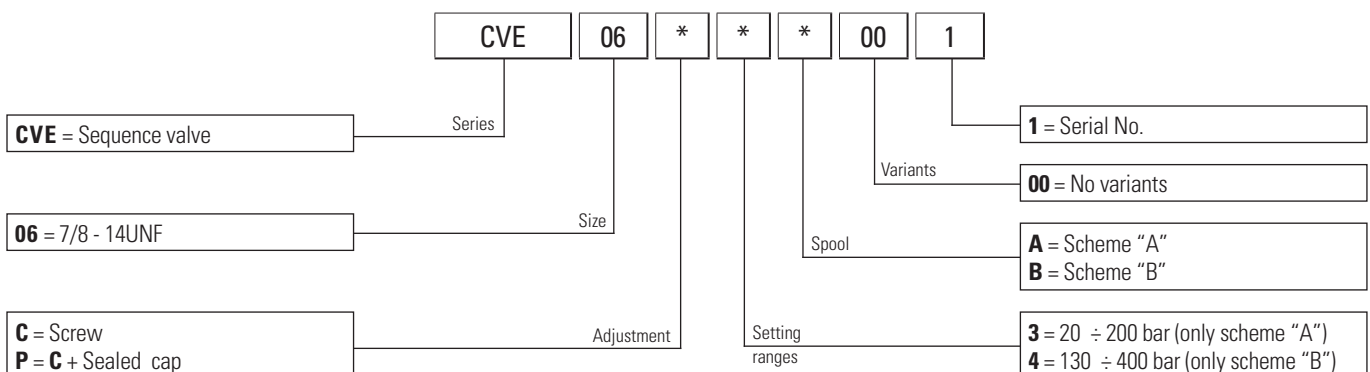

PRESSURE REDUCING AND SEQUENCE VALVES - IN-LINE MOUNTING

2

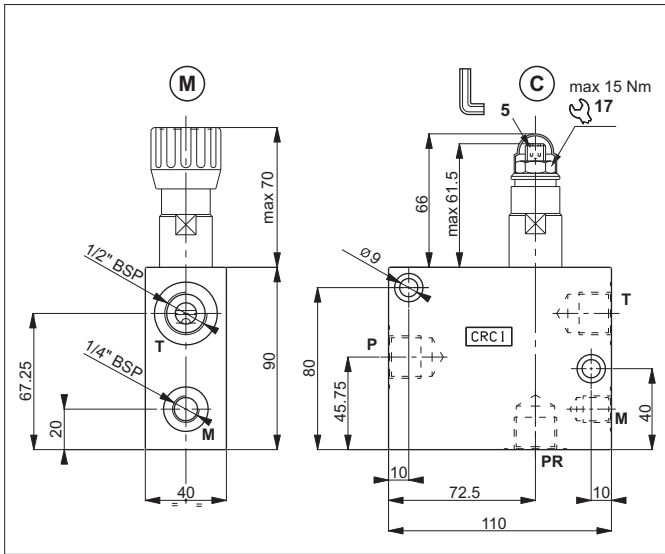

The CRC.1 aluminium body allows the in-line mounting connections for CVS.20 sequence and CVR.20 pressure reducing valves. In the version with pressure reducing valve the pump supply is connected to the port P, while in the version sequence valve is connected to the mouth PR.

For pressure reducing version the body is provided with a one-way check valve, which allows free flow to opposite direction (PR toward P)

For the sequence version a blind grub screw has been placed instead of a check valve.

- Mounting the blind grub screw , code **M78100013**, it is possible to transform the body from reducing valve to sequence valve.
- Mounting the blind grub screw , code **V70052204**, it is possible to transform the body from sequence valve to reducing valve.

HYDRAULIC SYMBOLS

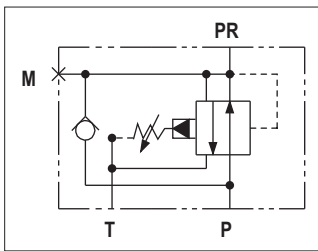

Reducing valve version

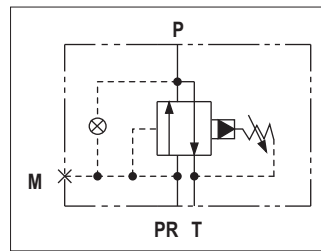

Sequence valve version

HYDRAULIC FEATURES

Max. pressure	350 bar
Setting range:	
Spring 1 (white)	max 60 bar
Spring 2 (yellow)	max 120 bar
Spring 3 (green)	max 250 bar
Max. Flow	90 l/min
Max. draining on port T	0.5 ÷ 0.7 l/min
Hydraulic fluid	DIN 51524 Mineral oils
Fluid viscosity	10 ÷ 500 mm ² /s
Fluid temperature	-25°C ÷ 75°C
Ambient temperature	-25°C ÷ 60°C
Max. contamin. level class with filter	ISO 4406:1999 - class 19/17/14
Weight	1.224 kg

FREE FLOW THROUGH THE CHECK VALVE

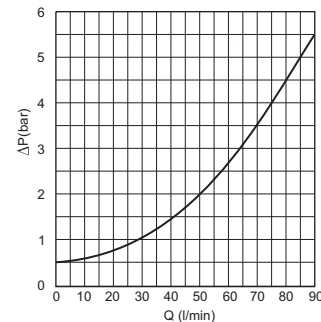

Fluid used: mineral based oil with viscosity 46 mm²/s at 40°C.

ORDERING CODE

CRC = Sequence and pressure reducing cartridge valve Size 20 (seat M22x1,5)	Series	CRC
1 = Size connection 1/2" BSP	Size	1
R = Pressure reducing cartridge valve S = Sequence cartridge valve	Adjustment	*
M = Plastic knob C = Screw O = Without cartridge valve	Adjustment	*
	Adjustment	*
	Setting ranges	**
	Setting ranges	1
	Variants	1 = Serial No.
	Variants	00 = No variants V1 = Viton
	Setting ranges	1 = 60 bar (white spring) 2 = 120bar (yellow spring) 3 = 250 bar (green spring) 0 = Without cartridge valve

DOUBLE CROSS RELIEF VALVES

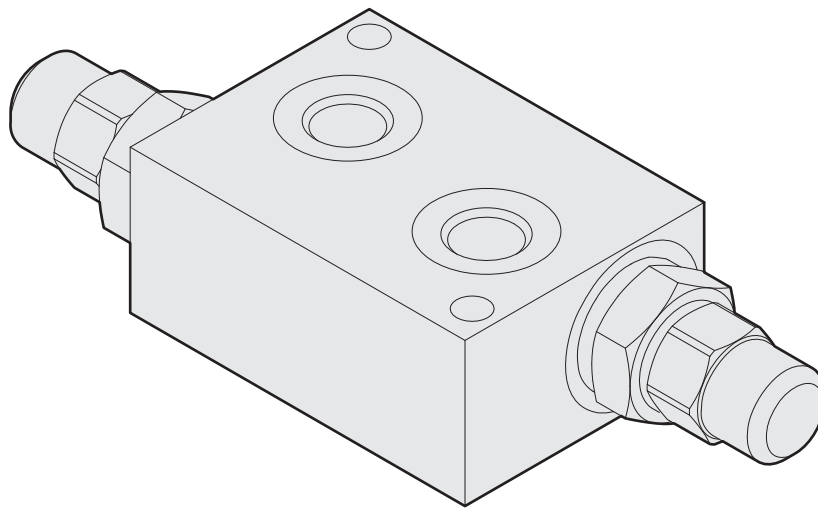

DOUBLE CROSS RELIEF VALVES DIRECT ACTING - IN-LINE MOUNTING

3

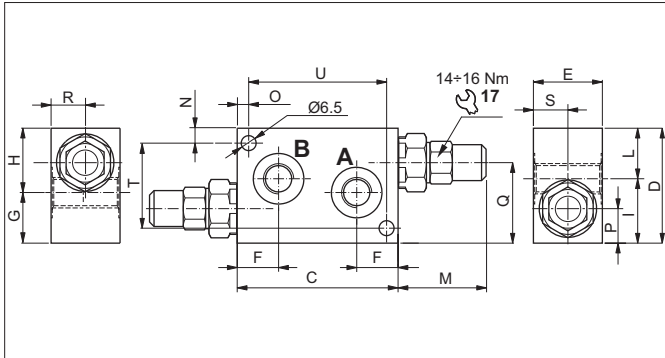

The direct acting compensator valves with CMP04 type cartridge protects the hydraulic components from impact or peaks in pressure. It raises the safety level by making it impossible for the plant operators to set a higher pressure rating, than that specified in the catalogue. It has a pack spring with a mechanical stop (only standard screw and nut). The body is in high-resistance aluminium and the cartridge is in galvanised steel.

HYDRAULIC SYMBOL

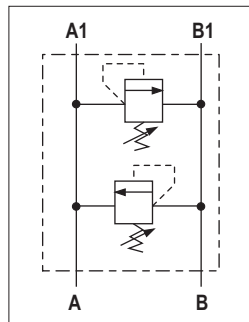

HYDRAULIC FEATURES

Max. pressure	
Size 1/4 BSP	250 bar
Size 3/8 BSP	250 bar
Max. Flow	
Size 1/4 BSP	30 l/min
Size 3/8 BSP	30 l/min
Hydraulic fluid	DIN 51524 Mineral oils
Fluid viscosity	10 ÷ 500 mm ² /s
Fluid temperature	-25°C ÷ 75°C
Ambient temperature	-25°C ÷ 60°C
Max. contamin. level class with filter	ISO 4406:1999 - class 19/17/14

Size	Ports A-B	Valve features see:	C (mm)	D (mm)	E (mm)	F (mm)	G (mm)	H (mm)	I (mm)	L (mm)	M (mm)	N (mm)	O (mm)	P (mm)	Q (mm)	R (mm)	S (mm)	T (mm)	U (mm)	Weight (kg)
04	1/4 BSP	CMP04	70	50	30	17.5	22	28	28	22	32	6.5	5	15	35	15	15	37	60	0.394
06	3/8 BSP	CMP04	70	50	30	18	20	30	30	20	32	6.5	5	15	35	15	15	37	60	0.400

ORDERING CODE

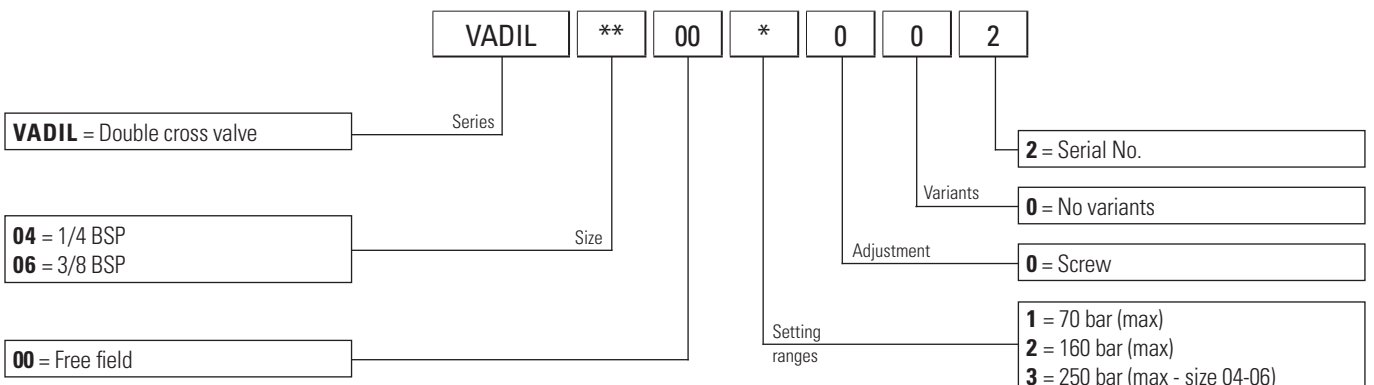

ONE-WAY CHECK VALVES

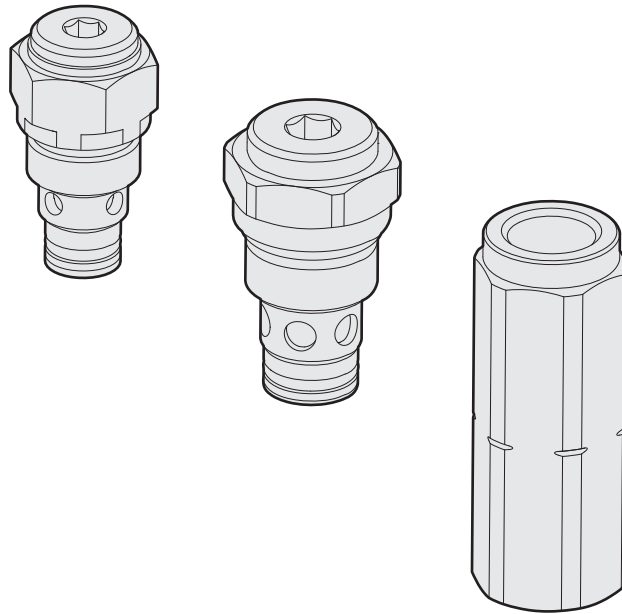

ONE-WAY CHECK VALVES

4

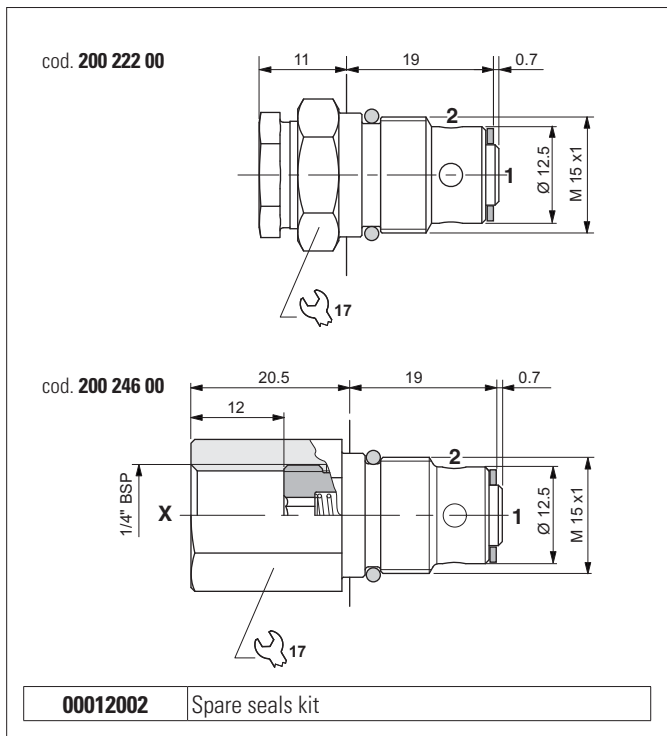

The unidirectional check valve allows oil to flow in only one direction. The guided ball seal is made of tempered and ground steel. The spring allows the valve to be mounted in any position. Also available with 1/4" BSP auxiliary pressure outlet. It has a galvanised steel body.

HYDRAULIC FEATURES

Max. working pressure	220 bar
Max. Flow	10 l/min
Max. Leakage (0 ÷ 5 drops/min)	0 ÷ 0.25 cm ³ /min
Crack pressure	1 bar
Hydraulic fluid	DIN 51524 Mineral oils
Fluid viscosity	10 ÷ 500 mm ² /s
Fluid temperature	-25°C ÷ 75°C
Ambient temperature	-25°C ÷ 60°C
Max. contamin. level class with filter	ISO 4406:1999 - class 19/17/14
Tightening torque	16 ÷ 19 Nm
Cavity (M15x1)	CN033001 (See section 17)

HYDRAULIC SYMBOLS

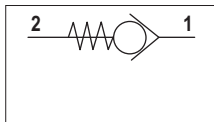

cod. 20022200

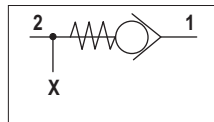

cod. 20024600

ORDERING CODE

Code	Type	Weight
20022200	2 way	0.035 kg
20024600	3 way	0.042 kg

PRESSURE DROPS

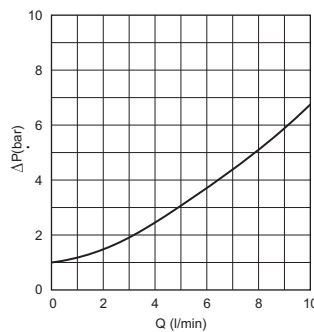

Fluid used: mineral based oil with viscosity 32 mm²/s at 50°C.

ONE-WAY CHECK VALVES

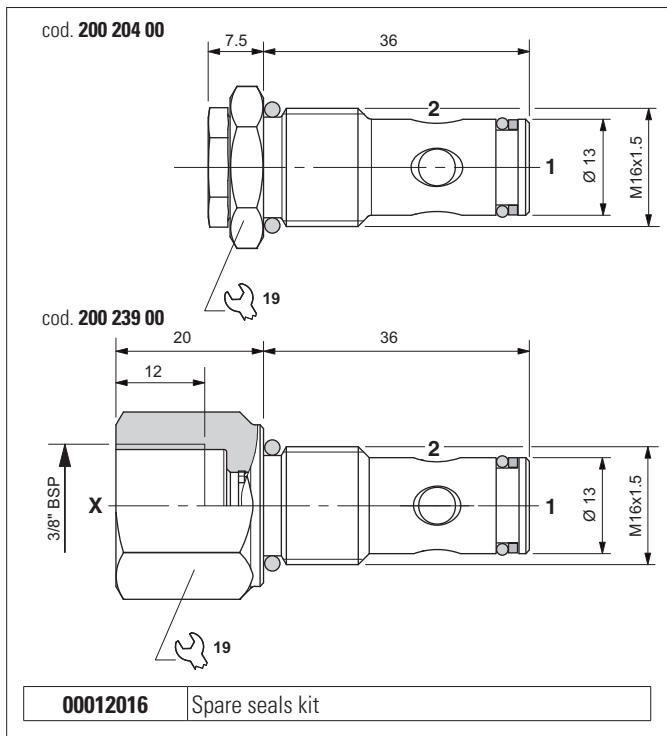

The unidirectional check valve allows oil to flow in only one direction. The guided ball seal is made of tempered and ground steel. The spring allows the valve to be mounted in any position. Also available with 1/4" BSP auxiliary pressure outlet. It has a galvanised steel body.

HYDRAULIC FEATURES

Max. working pressure	210 bar
Max. Flow	20 l/min
Max. Leakage (0 ÷ 5 drops/min)	0 ÷ 0.25 cm ³ /min
Crack pressure	0.5 bar
Hydraulic fluid	DIN 51524 Mineral oils
Fluid viscosity	10 ÷ 500 mm ² /s
Fluid temperature	-25°C ÷ 75°C
Ambient temperature	-25°C ÷ 60°C
Max. contamin. level class with filter	ISO 4406:1999 - class 19/17/14
Tightening torque	28 ÷ 32 Nm
Cavity (M16x1.5)	CN03704 (See section 17)

4

HYDRAULIC SYMBOLS

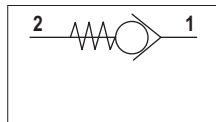

cod. 20020400

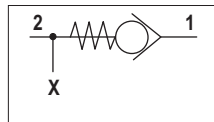

cod. 20023900

ORDERING CODE

Code	Type	Weight
20020400	2 way	0.041 kg
20023900	3 way	0.070 kg

PRESSURE DROPS

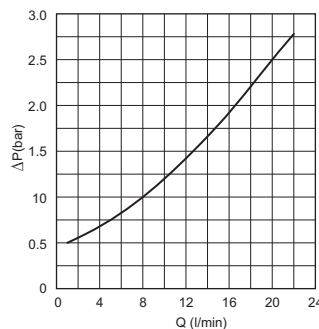

Fluid used: mineral based oil with viscosity 32 mm²/s at 50°C.

ONE-WAY CHECK VALVES

4

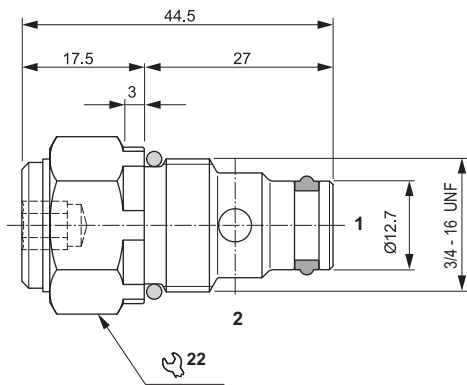

00012003 Spare seals kit

The check-valves permit one-directional oil flow only. On the opposite side the sealing is guaranteed by a hardened and ground taper steel poppet. The spring permits an easy valve installation in any position. External steel body protected on surface by zinc plating.

HYDRAULIC FEATURES

Max. working pressure	350 bar
Max. Flow	40 l/min
Max. Leakage (0 ÷ 5 drops/min)	0 ÷ 0.25 cm ³ /min
Hydraulic fluid	DIN 51524 Mineral oils
Fluid viscosity	10 ÷ 500 mm ² /s
Fluid temperature	-25°C ÷ 75°C
Ambient temperature	-25°C ÷ 60°C
Max. contamin. level class with filter	ISO 4406:1999 - class 19/17/14
Weight	0.08 kg
Tightening torque	25 ÷ 30 Nm
Cavity (3/4 - 16 UNF)	CD018006 (See section 17)

HYDRAULIC SYMBOL

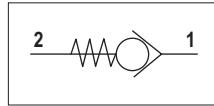

PILOT SPOOL

Single

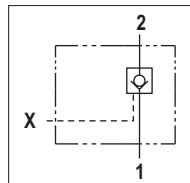
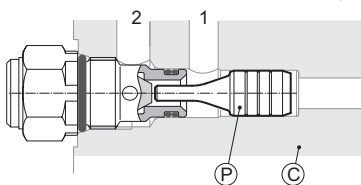

Double

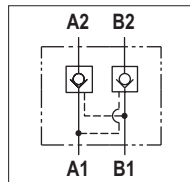
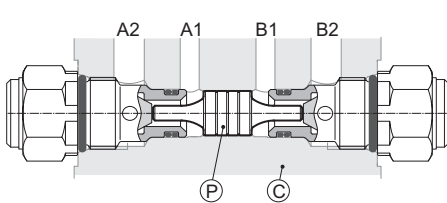

Type	Spool (P) code	Cavity (C) (See section 17)	Pilot ratio
Single	F63400002	CD018015	1 : 2.9
Double	F63400003	CD018016	1 : 2.9

PRESSURE DROPS

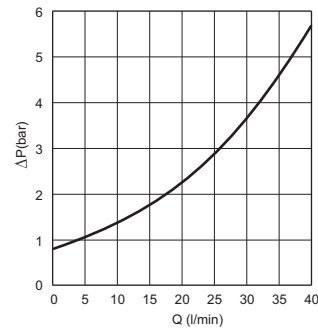

Fluid used: mineral based oil with viscosity 46 mm²/s at 40°C.

ORDERING CODE

CRU 04 ** 00 2

CRU = Check valve

Series

2 = Serial No.

04 = 3/4 - 16 UNF

Size

01 = 0.3 bar
00 = 0.7 bar (standard)
04 = 4.5 bar
07 = 7.5 bar
10 = 10 bar

Opening pressure

Variants

00 = No variants

ONE-WAY CHECK VALVES

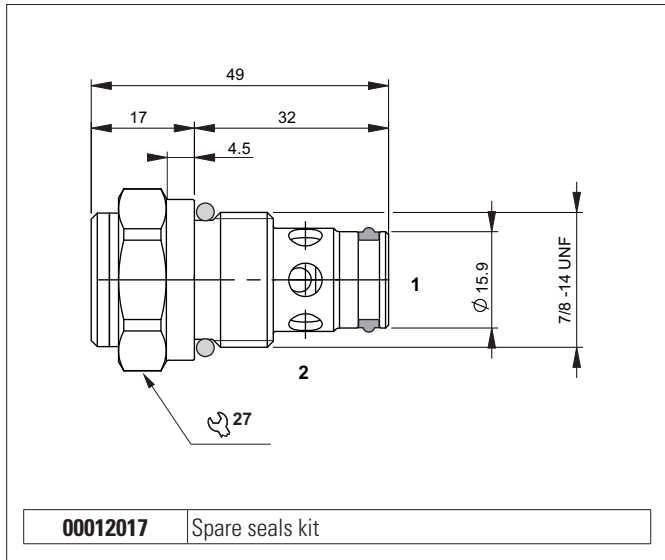

The check-valves permit one-directional oil flow only. On the opposite side the sealing is guaranteed by a hardened and ground taper steel poppet. The spring permits an easy valve installation in any position. External steel body protected on surface by zinc plating.

HYDRAULIC FEATURES

Max. working pressure	350 bar
Max. Flow	60 l/min
Max. Leakage (0 ÷ 5 drops/min)	0 ÷ 0.25 cm ³ /min
Hydraulic fluid	DIN 51524 Mineral oils
Fluid viscosity	10 ÷ 500 mm ² /s
Fluid temperature	-25°C ÷ 75°C
Ambient temperature	-25°C ÷ 60°C
Max. contamin. level class with filter	ISO 4406:1999 - class 19/17/14
Weight	0.10 kg
Tightening torque	35 ÷ 40 Nm
Cavity (7/8 - 14 UNF)	CD019007 (See section 17)

4

HYDRAULIC SYMBOL

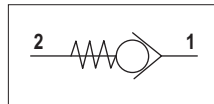

PRESSURE DROPS

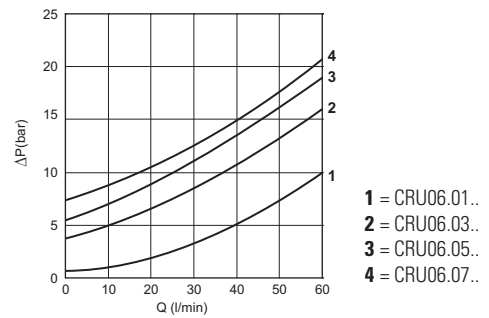

Fluid used: mineral based oil with viscosity 46 mm²/s at 40°C.

ORDERING CODE

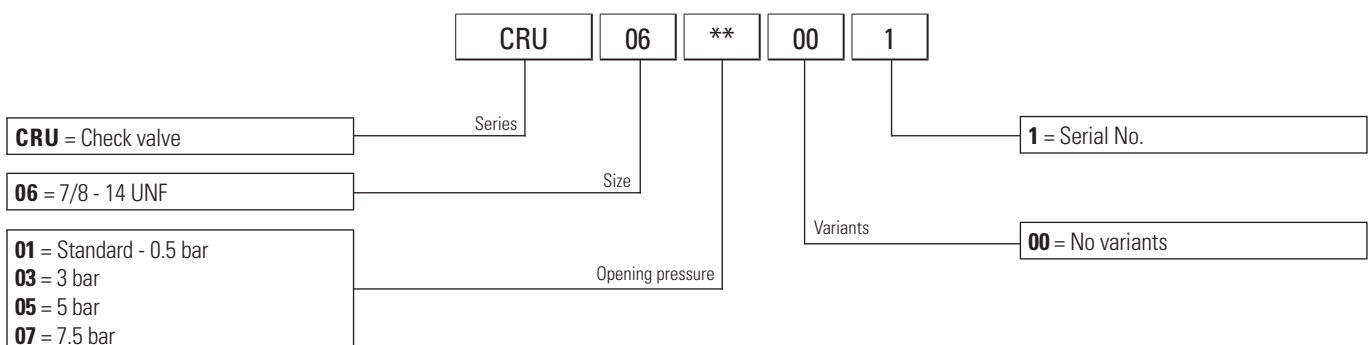

ONE-WAY CHECK VALVES (FOR POWER PACKS SERIES FP)

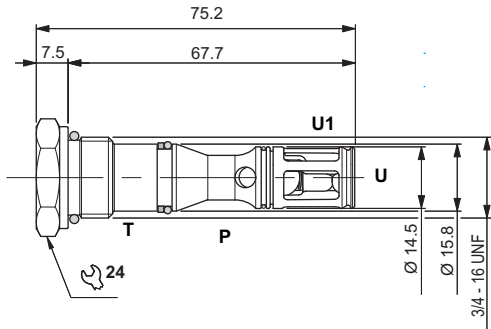

00012004 Spare seals kit

The check-valves permit one-directional oil flow only. On the opposite side the sealing is guaranteed by a ball steel poppet. The spring permits an easy valve installation in any position. External steel body protected on surface by zinc plating.

HYDRAULIC FEATURES

Max. working pressure	320 bar
Max. Flow	20 l/min
Max. Leakage (0 ÷ 5 drops/min)	0 ÷ 0.25 cm ³ /min
Hydraulic fluid	DIN 51524 Mineral oils
Fluid viscosity	10 ÷ 500 mm ² /s
Fluid temperature	-25°C ÷ 75°C
Ambient temperature	-25°C ÷ 60°C
Max. contamin. level class with filter	ISO 4406:1999 - class 19/17/14
Weight	0.09 kg
Tightening torque	25 ÷ 30 Nm
Cavity (3/4 - 16 UNF)	CD018013 (See section 17)

HYDRAULIC SYMBOL

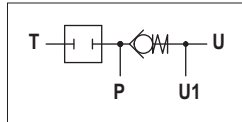

PRESSURE DROPS (P → U)

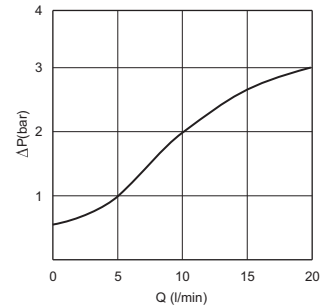

Fluid used: mineral based oil with viscosity 32 mm²/s at 50°C.

ORDERING CODE

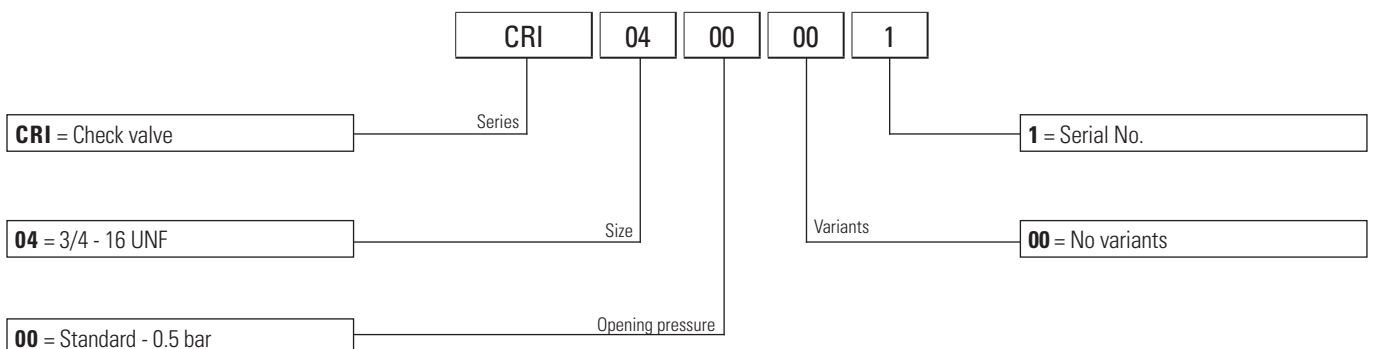

ONE-WAY CHECK VALVES

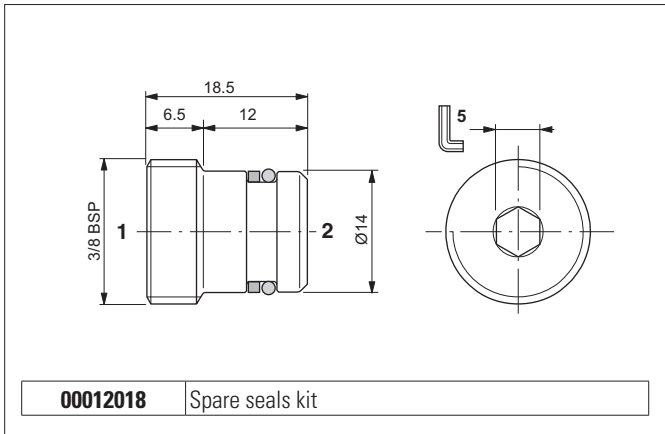

The unidirectional check valve allows oil to flow in only one direction. The guided ball seal is made of tempered and ground steel. The spring allows the valve to be mounted in any position. Steel body.

HYDRAULIC FEATURES

Max. working pressure	300 bar
Max. Flow	30 l/min
Max. Leakage (0 ÷ 5 drops/min)	0 ÷ 0.25 cm ³ /min
Hydraulic fluid	DIN 51524 Mineral oils
Fluid viscosity	10 ÷ 500 mm ² /s
Fluid temperature	-25°C ÷ 75°C
Ambient temperature	-25°C ÷ 60°C
Max. contamin. level class with filter	ISO 4406:1999 - class 19/17/14
Weight	0.09 kg
Tightening torque	16 ÷ 18 Nm
Cavity (3/8 BSP)	CG03004 (See section 17)

4

HYDRAULIC SYMBOL

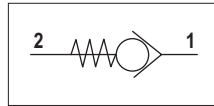

PRESSURE DROPS

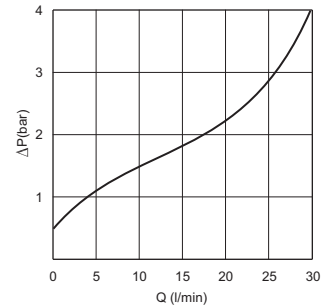

Fluid used: mineral based oil with viscosity 32 mm²/s at 40°C.

ORDERING CODE

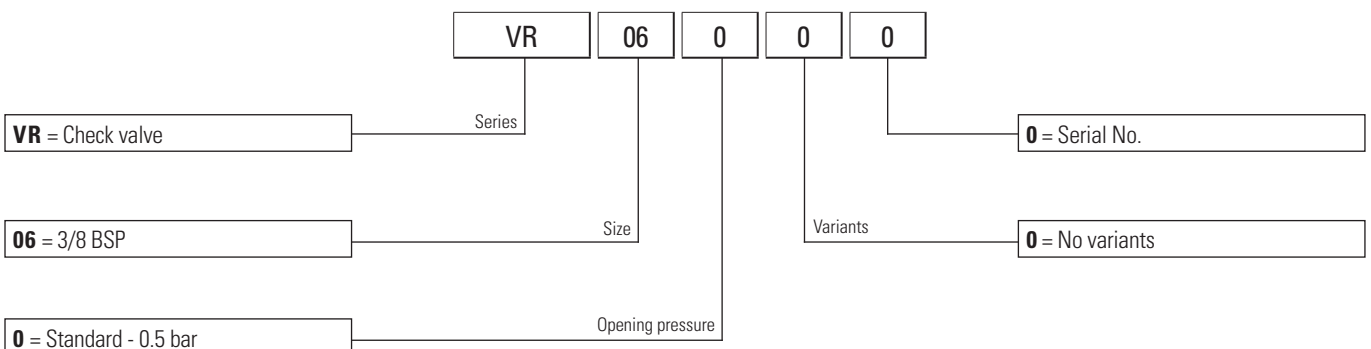

ONE-WAY CHECK VALVES

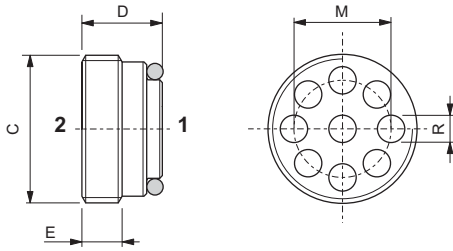

The unidirectional check valve allows oil to flow in only one direction. The guided half-ball seal is made of tempered and ground steel. The spring allows the valve to be mounted in any position. Steel body.

HYDRAULIC FEATURES

Max. Leakage (0 ÷ 5 drops/min)	0 ÷ 0.25 cm ³ /min
Hydraulic fluid	DIN 51524 Mineral oils
Fluid viscosity	10 ÷ 500 mm ² /s
Fluid temperature	-25°C ÷ 75°C
Ambient temperature	-25°C ÷ 60°C
Max. contamin. level class with filter	ISO 4406:1999 - class 19/17/14

4

C	Flow max (l/min)	Pressure max (bar)	M (mm)	R (mm)	D (mm)	E (mm)	Tightening torque (Nm)	Weight (kg)
1/4 BSP	20	350	8.5	2.2	8.5	4.4	6	0.005
3/8 BSP	50	350	10.8	3	11.3	6	6	0.011
1/2 BSP	80	350	14.2	3.8	12.7	6.5	10	0.019

HYDRAULIC SYMBOL

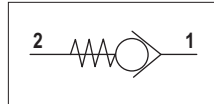

SEAL

C	F (mm)	L (mm)
1/4 BSP	7	3
3/8 BSP	9	3.5
1/2 BSP	12	4.5

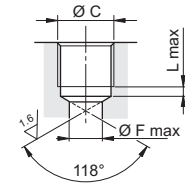

KEY FOR TIGHTENING VALVE

Code key	For valve	D (mm)	L (mm)	L1 (mm)	L2 (mm)
AVA174	VUI0400	11.4	120	105.5	100
AVA176	VUI0600	14.9	120	105.5	100
AVA178	VUI0800	18.6	120	105.5	100

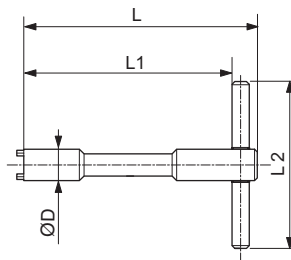

PRESSURE DROPS

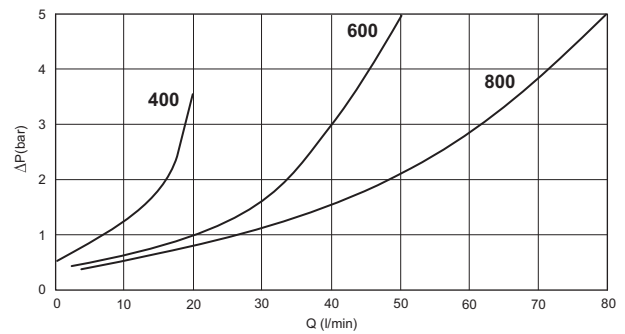

Fluid used: mineral based oil with viscosity 32 mm²/s at 40°C.

ORDERING CODE

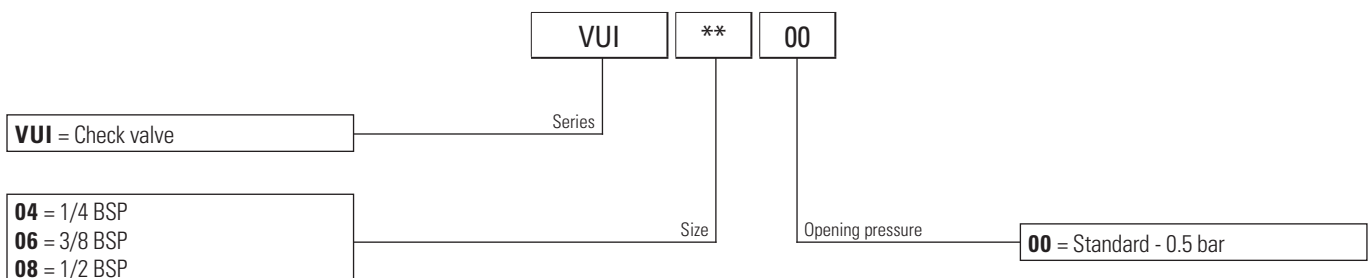

ONE-WAY CHECK VALVES - IN-LINE MOUNTING

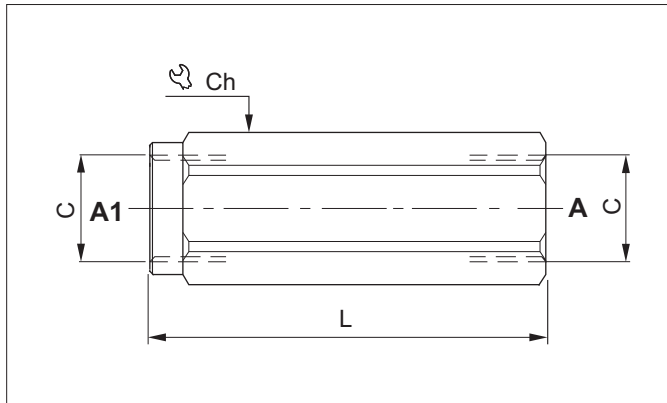

The check-valves permit one-directional oil flow only. On the opposite side the sealing is guaranteed by a hardened and ground taper steel poppet. The spring permits an easy valve installation in any position. External steel body protected on surface by a zinc plating.

HYDRAULIC FEATURES

Max. Leakage (0 ÷ 5 drops/min)	0 ÷ 0.25 cm ³ /min
Hydraulic fluid	DIN 51524 Mineral oils
Fluid viscosity	10 ÷ 500 mm ² /s
Fluid temperature	-25°C ÷ 75°C
Ambient temperature	-25°C ÷ 60°C
Max. contamin. level class with filter	ISO 4406:1999 - class 19/17/14

4

HYDRAULIC SYMBOL

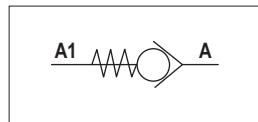

Code	C	Flow max (l/min)	Pressure max (bar)	L (mm)	Ch (mm)	Weight (kg)
VRU0400	1/4 BSP	20	350	59	19	0.10
VRU0600	3/8 BSP	35	350	66	24	0.17
VRU0800	1/2 BSP	50	350	78	27	0.24
VRU1200	3/4 BSP	85	300	90	36	0.49
VRU1600	1 BSP	140	250	112	40	0.67
VRU2000	1- 1/4 BSP	200	250	142	55	1.68
VRU2400	1- 1/2 BSP	310	210	155	60	2.10

PRESSURE DROPS

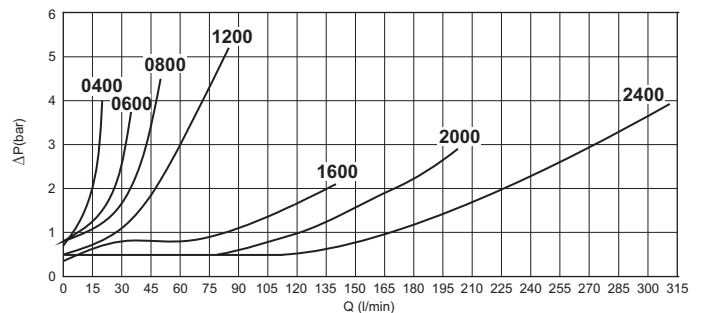

Fluid used: mineral based oil with viscosity 15 mm²/s at 40°C.

ORDERING CODE

VRU = Check valve

VRU

Series

Size

CODE	04	06	08	12	16	20	24
00	0.7*	0.5*	0.5*	0.5*	0.5*	0.5*	0.5*
02				2*	2*		
03	4.5*	3*	3*	3*			
05	7.5*	5*	5*				
10	10*				10*		

Setting pressure

04 = 1/4 BSP
 06 = 3/8 BSP
 08 = 1/2 BSP
 12 = 3/4 BSP
 16 = 1 BSP
 20 = 1- 1/4 BSP
 24 = 1- 1/2 BSP

Standard
 * Pressure - bar

CHECK VALVES FOR PIPES

4

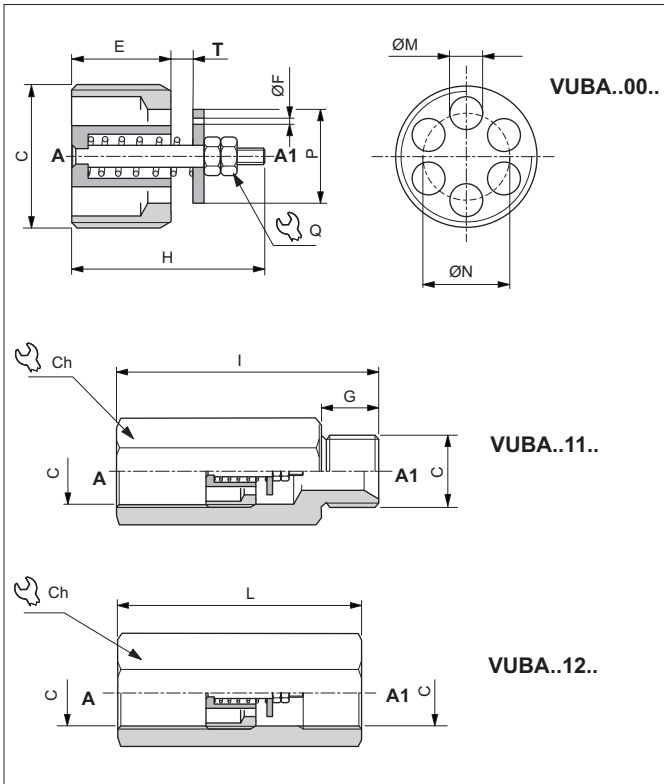

The pipe-pressure check valve is fitted directly on cylinder connections to prevent uncontrolled drops due to system faults. Supplied on request with a flow reducer hole F on the plate to enable leakage from A1 to A and allow the load to drop slowly. Steel body and plate. Seal surfaces lapped.

HYDRAULIC FEATURES

Max. Leakage (0 ÷ 5 drops/min)	0 ÷ 0.25 cm ³ /min
Hydraulic fluid	DIN 51524 Mineral oils
Fluid viscosity	10 ÷ 500 mm ² /s
Fluid temperature	-25°C ÷ 75°C
Ambient temperature	-25°C ÷ 60°C
Max. contamin. level class with filter	ISO 4406:1999 - class 19/17/14

HYDRAULIC SYMBOL

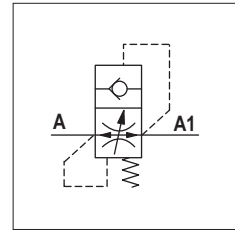

Code	C	Flow min (l/min)	Flow max (l/min)	Pressure max (bar)	E (mm)	F (mm)	G (mm)	H (mm)	I (mm)	L (mm)	M (mm)	N (mm)	P (mm)	Q (mm)	T* (mm)	Ch (mm)	Tightening torque (Nm)	Weight (kg)		
																		VUBA..00.	VUBA..11.	VUBA..12.
VUBA0400..	1/4 BSP	4	25	350	8	0.5 - 0.6	11	17.5	61	61	2.4	8.5	9.5	5.5	0.2 ÷ 1.0	19	2	0.007	0.07	0.09
VUBA0600 ..	3/8 BSP	6	50	350	10.5	0.8 - 1.0	13	23	63	63	3.5	10.5	12.5	5.5	0.2 ÷ 2.0	22	3	0.012	0.10	0.11
VUBA0800 ..	1/2 BSP	16	80	350	12	1.2 - 1.3	14	25	72	65	4.5	13	15	7	0.4 ÷ 2.6	27	4	0.023	0.17	0.16
VUBA1200 ..	3/4 BSP	25	150	350	17	1.5 - 1.9	17	30.5	104	72	6	16	18	7	0.3 ÷ 2.8	32	10	0.047	0.25	0.21

* Specify distance "T" with decimal progression. Standard distance "T" is 0.5 mm (for 1/4 and 3/8 BSP valves) and 0.7 mm (for 1/2 and 3/4 BSP valves). Response flow depends on distance "T" see "T adjustment curves".

DIAGRAMS FOR "T" ADJUSTEMENT

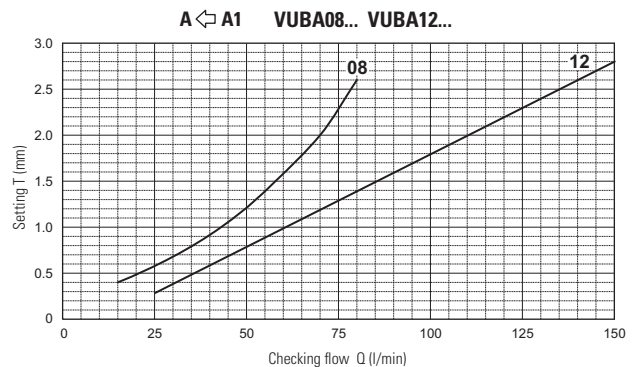
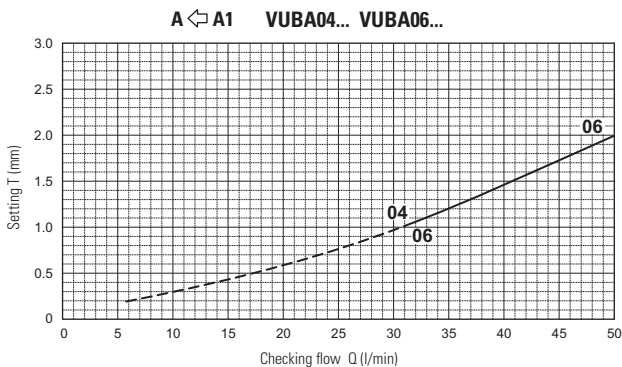

Distance "T" must correspond to a flow rate of at least 50% top than the set flow. The flow of checking flow may be ±10% on given curve. Fluid used: mineral based oil with viscosity 46 mm²/s at 40°C.

FLOW PRESSURE DROP ACCORDING ADJUSTEMENT "T"

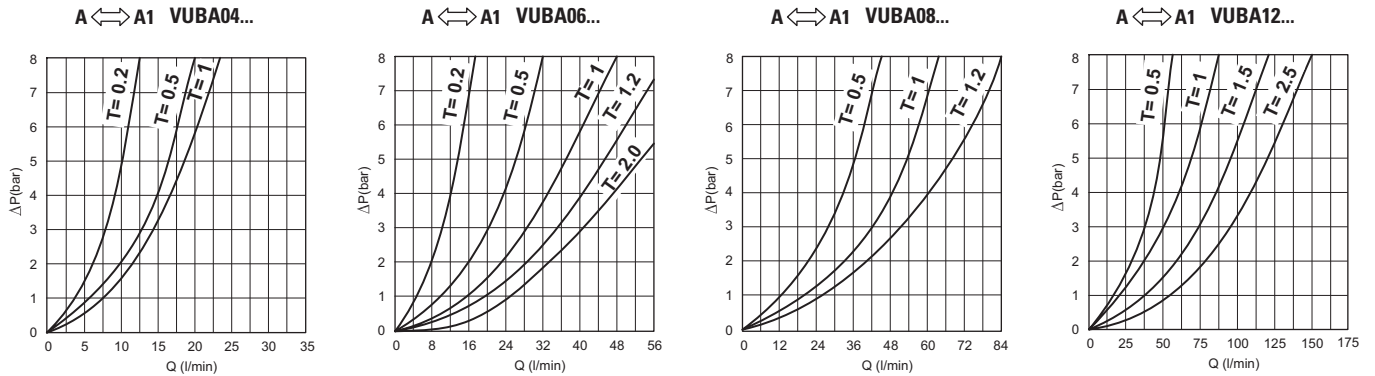

Diagrams flow pressure drop according adjustment length of "T"

KEY FOR TIGHTENING VALVE

Code key	For valve	D (mm)	L (mm)	L1 (mm)	L2 (mm)
AVA184	VUBA04..	11.3	120	110	60
AVA186	VUBA06..	15	120	110	80
AVA188	VUBA08..	18.8	120	108	80
AVA1812	VUBA12..	24	120	108	80

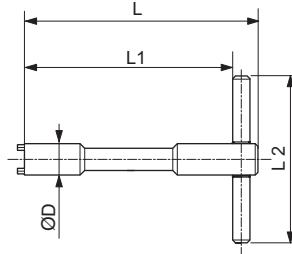

SERVICE EXAMPLE

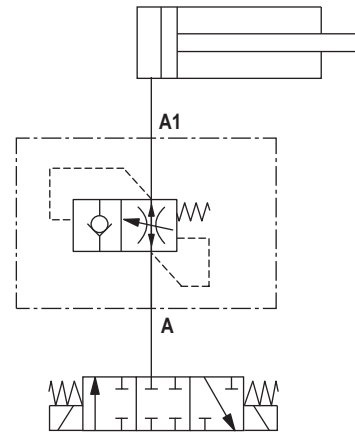

SEAL

C	H (mm)
1/4 BSP	11
3/8 BSP	11
1/2 BSP	15
3/4 BSP	16

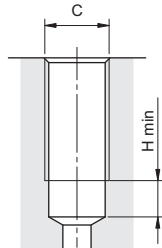

ORDERING CODE

VUBA	**	**	T***	F**
Series	Size	Versions	Setting T	Hole on the plate

VUBA = Check valve

04 = 1/4 BSP
06 = 3/8 BSP
08 = 1/2 BSP
12 = 3/4 BSP

00 = Cartridge only
11 = Complete valve M/F
12 = Complete valve F/F
01 = Only column M/F
02 = Only column F/F

NOTE:
(1-2) Special, minimum 100 pieces.
(2) Specify distance "T" with decimal progression (e.g. T020 = 0.20 mm).

Standard, without hole (omit code)	
Special holes (1)	
05 = 0.5 (mm)	13 = 1.3 (mm)
06 = 0.6 (mm)	15 = 1.5 (mm)
08 = 0.8 (mm)	19 = 1.9 (mm)
10 = 1.0 (mm)	20 = 2.0 (mm)
12 = 1.2 (mm)	

Standard settings (omit code)	
0.5 mm for dimensions 04-06	
0.7 mm for dimensions 08-12	

Special settings (2)	
020 ÷ 100 = 0.2 ÷ 1.0 mm for dimension 04	
020 ÷ 200 = 0.2 ÷ 2.0 mm for dimension 06	
040 ÷ 260 = 0.4 ÷ 2.6 mm for dimension 08	
030 ÷ 280 = 0.3 ÷ 2.8 mm for dimension 12	

4

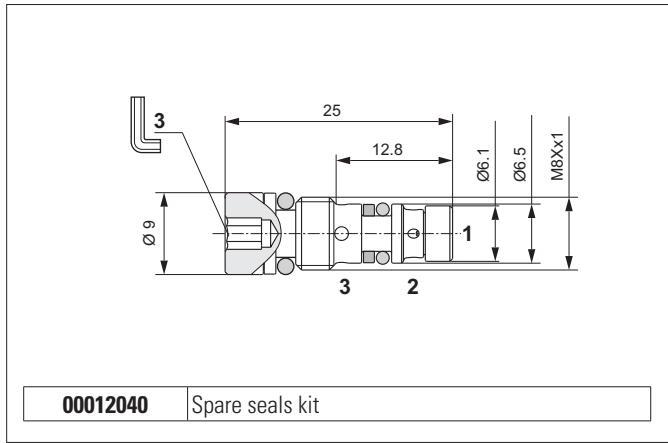

The shuttle type cartridge valves allow taking of the highest pressure signal to the external port via displacement of tempered and ground steel ball. There are usually employed to signal the actuator load to a load sensing pump pressure compensator. External steel body.

HYDRAULIC FEATURES

Max. working pressure	350 bar
Max. Flow	2 l/min
Hydraulic fluid	DIN 51524 Mineral oils
Fluid viscosity	10 ÷ 500 mm ² /s
Fluid temperature	-25°C ÷ 75°C
Ambient temperature	-25°C ÷ 60°C
Max. contamin. level class with filter	ISO 4406:1999 - class 19/17/14
Weight	0.0065 kg
Tightening torque	16 ÷ 18 Nm
Cavity (M8 x 1)	CA007001 (See section 17)

HYDRAULIC SYMBOL

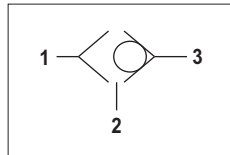

PRESSURE DROPS

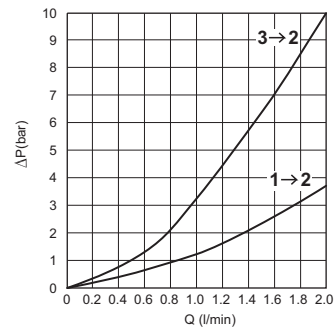

Fluid used: mineral based oil with viscosity 32 mm²/s at 40°C.

ORDERING CODE

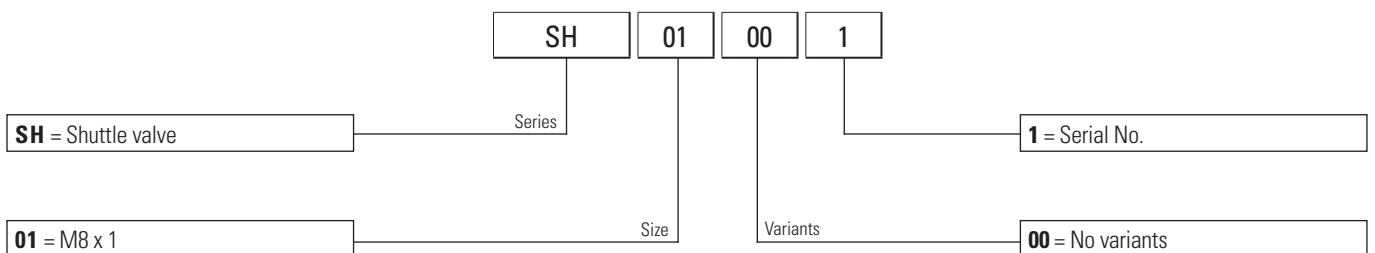

SHUTTLE VALVES

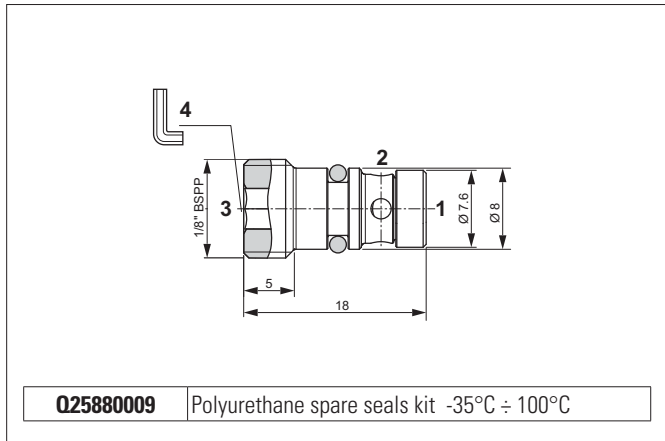

The shuttle type cartridge valves allow taking of the highest pressure signal to the external port via displacement of tempered and ground steel ball. There are usually employed to signal the actuator load to a load sensing pump pressure compensator. External steel body.

HYDRAULIC FEATURES

Max. working pressure	400 bar
Max. Flow	8 l/min
Hydraulic fluid	DIN 51524 Mineral oils
Fluid viscosity	10 ÷ 500 mm ² /s
Fluid temperature	-25°C ÷ 75°C
Ambient temperature	-25°C ÷ 60°C
Max. contamin. level class with filter	ISO 4406:1999 - class 19/17/14
Weight	0.006 kg
Tightening torque	16 ÷ 18 Nm
Cavity (G 1/8)	CG001002 (See section 17)

4

HYDRAULIC SYMBOL

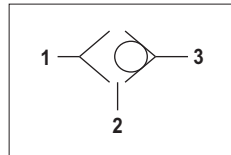

PRESSURE DROPS

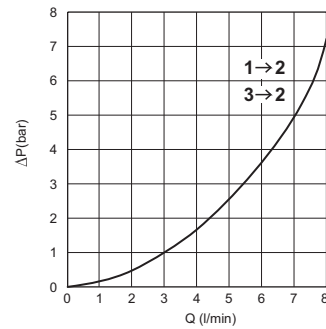

Fluid used: mineral based oil with viscosity 46 mm²/s at 40°C.

ORDERING CODE

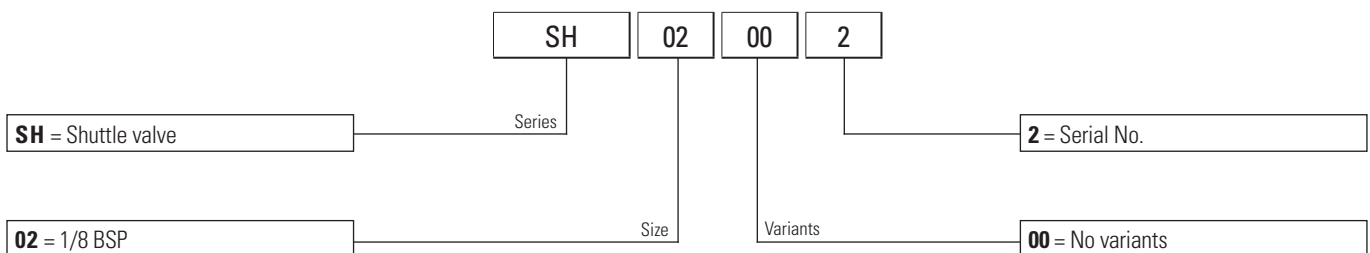

SHUTTLE VALVES

4

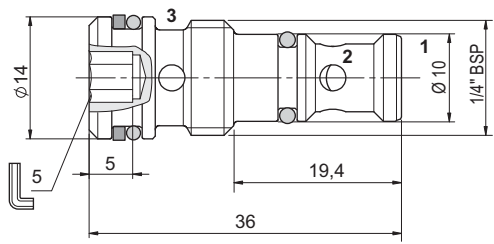

00012019 Spare seals kit

The shuttle type cartridge valves allow taking of the highest pressure signal to the external port via displacement of ball in tempered and ground steel. There are usually employed to signal the actuator load to a load sensing pump pressure compensator. External steel body protected on surface by zinc plating.

HYDRAULIC FEATURES

Max. working pressure	350 bar
Max. Flow	5 l/min
Max. Leakage (0 ÷ 5 drops/min)	0 ÷ 0.25 cm ³ /min
Hydraulic fluid	DIN 51524 Mineral oils
Fluid viscosity	10 ÷ 500 mm ² /s
Fluid temperature	-25°C ÷ 75°C
Ambient temperature	-25°C ÷ 60°C
Max. contamin. level class with filter	ISO 4406:1999 - class 19/17/14
Weight	0.023 kg
Tightening torque	18 ÷ 20 Nm
Cavity (1/4 BSP)	CA012001 (See section 17)

HYDRAULIC SYMBOL

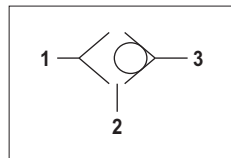

PRESSURE DROPS

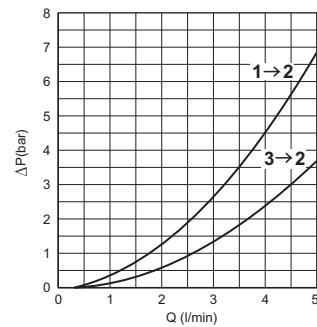

Fluid used: mineral based oil with viscosity 46 mm²/s at 40°C.

ORDERING CODE

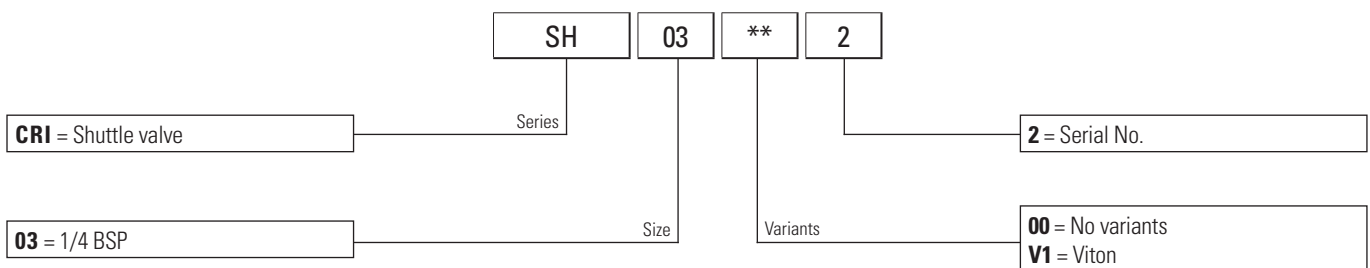

SHUTTLE VALVES

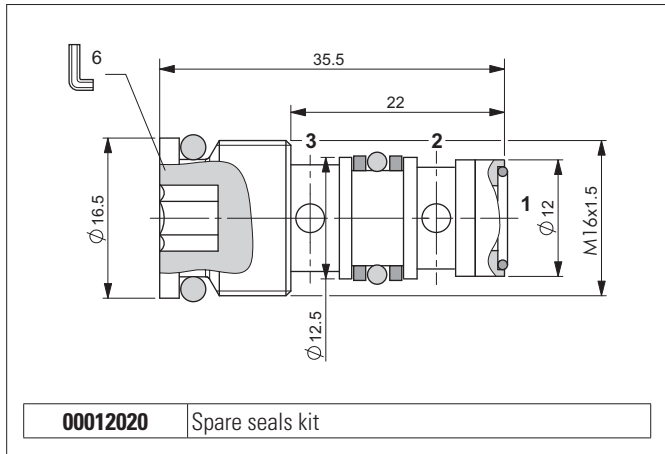

HYDRAULIC SYMBOL

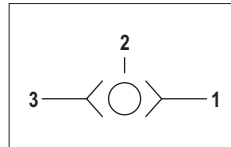

The shuttle type cartridge valves allow taking of the highest pressure signal to the external port via displacement of ball in tempered and ground steel. There are usually employed to signal the actuator load to a load sensing pump pressure compensator. External steel body protected on surface by zinc plating.

4

HYDRAULIC FEATURES

Max. working pressure	380 bar
Max. Flow	10 l/min
Max. Leakage (0 ÷ 5 drops/min)	0 ÷ 0.25 cm ³ /min
Hydraulic fluid	DIN 51524 Mineral oils
Fluid viscosity	10 ÷ 500 mm ² /s
Fluid temperature	-25°C ÷ 75°C
Ambient temperature	-25°C ÷ 60°C
Max. contamin. level class with filter	ISO 4406:1999 - class 19/17/14
Weight	0.029 kg
Tightening torque	16 ÷ 18 Nm
Cavity (M16x1.5)	CN037003 (See section 17)

ORDERING CODE

Code	Type
RVLV0101160	Shuttle valve

PRESSURE DROPS

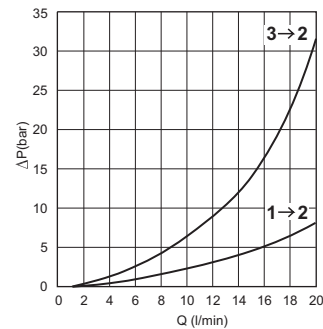

Fluid used: mineral based oil with viscosity 46 mm²/s at 40°C.

PUMP UNLOADING VALVES

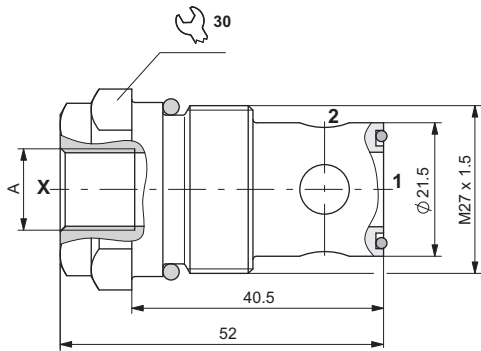

A = 1/4 BSP (RVLV1..2270)
SAE 7/16 20UNF (RVLV1..2150)

00012021 Spare seals kit

HYDRAULIC SYMBOL

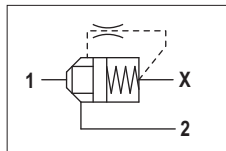

The normally-closed 2-way 2-position valve is used to connect a normally pressurised branch to the outlet in order to allow fluid to flow through the valve from 2 to 1.

Tapered poppet in tempered and ground steel, released when the pilot branch X is connected to the outlet.

It has a galvanised steel body.

HYDRAULIC FEATURES

Max. working pressure	380 bar
Max. Flow	140 l/min
Max. Leakage (0 ÷ 5 drops/min)	0 ÷ 0.25 cm ³ /min
Hydraulic fluid	DIN 51524 Mineral oils
Fluid viscosity	10 ÷ 500 mm ² /s
Fluid temperature	-25°C ÷ 75°C
Ambient temperature	-25°C ÷ 60°C
Max. contamin. level class with filter	ISO 4406:1999 - class 19/17/14
Weight	0.1422 kg
Tightening torque	22 ÷ 26 Nm
Cavity (M27x1.5)	CN059001 (See section 17)

ORDERING CODE

Code	Type
RVLV1202270	Pump unloading valve (A = 1/4 BSP)
RVLV12021S0	Pump unloading valve (A = SAE 7/16 20UNF)

PRESSURE DROPS

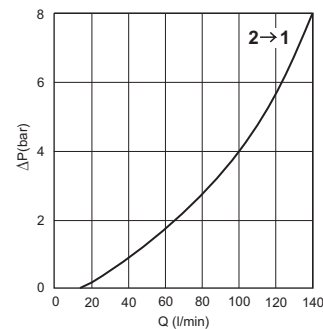

Fluid used: mineral based oil with viscosity
46 mm²/s at 40°C.

PILOT CHECK VALVES

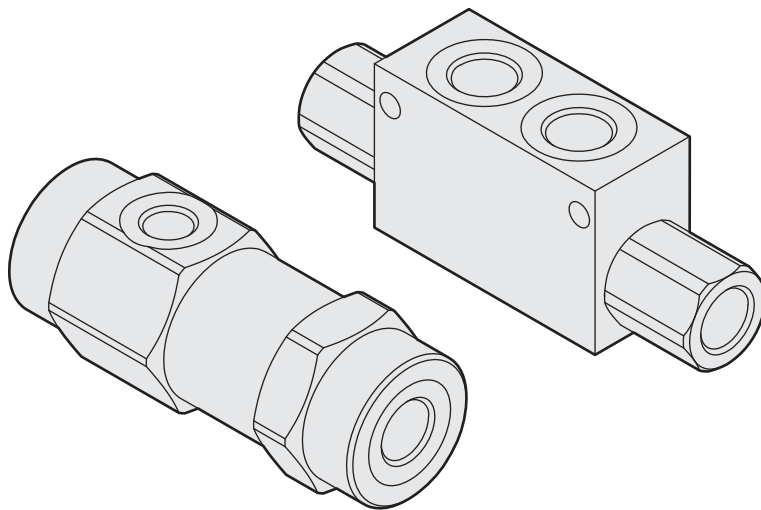

SINGLE ACTING PILOTED CHECK VALVES - IN-LINE MOUNTING

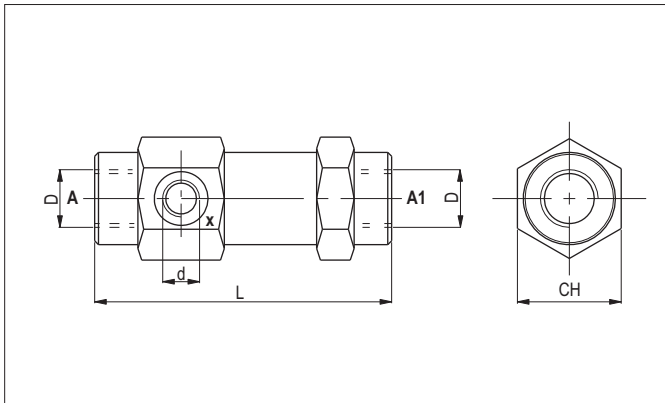

The pilot-operated check valve blocks a single-acting actuator in any position. Tapered poppet in tempered and ground steel, released by feeding the piloted opening X. Can be mounted in any position; galvanised.

5

HYDRAULIC FEATURES

Max. working pressure	350 bar
Standard opening pressure	0.5 bar
Max. Leakage (0 ÷ 20 drops/min)	0 ÷ 1 cm ³ /min
Piloting ratio	See table
Max. Flow	85 l/min
Hydraulic fluid	DIN 51524 Mineral oils
Fluid viscosity	2.8 ÷ 380 mm ² /s
Fluid temperature	-25°C ÷ 75°C
Ambient temperature	-25°C ÷ 60°C
Max. contamin. level class with filter	ISO 4406:1999 - class 19/17/14
Weight	See table

Code	Flow max (l/min)	Pressure max (bar)	L (mm)	Ch (mm)	Piloting ratio	d	D	Weight (kg)
VRS07	12	350	103	36	1:9	1/4 BSP	1/4 BSP	0.65
VRS10	30	310	109	40	1:6	1/4 BSP	3/8 BSP	0.82
VRS13	45	310	120	42	1:4.5	1/4 BSP	1/2 BSP	0.96
VRS19	85	300	131	55	1:3.7	1/4 BSP	3/4 BSP	1.95

HYDRAULIC SYMBOL

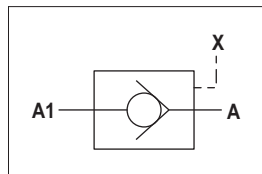

PRESSURE DROPS - FLOW

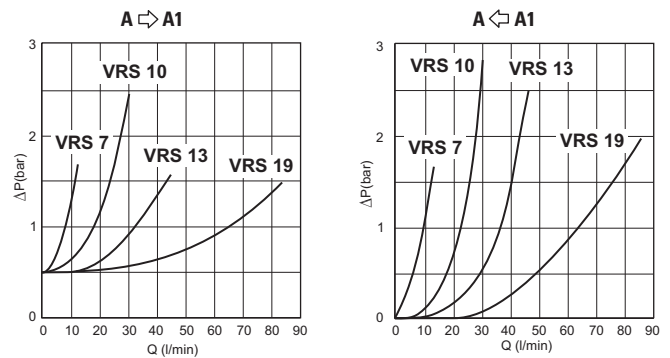

Fluid used: mineral based oil with viscosity 24 mm²/s at 50°C.

ORDERING CODE

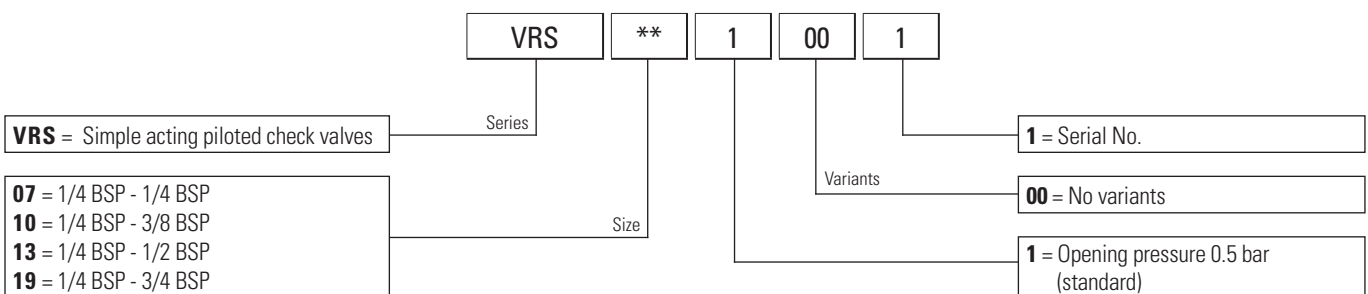

SINGLE AND DOUBLE ACTING PILOT CHECK VALVES - IN-LINE MOUNTING

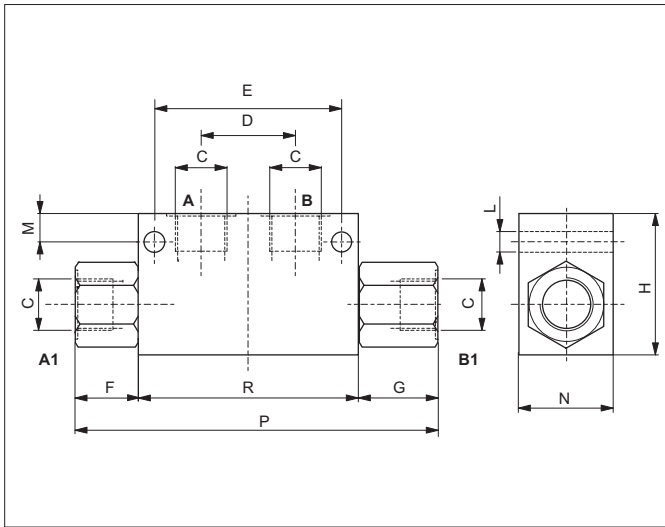

With the acting pilot check valves, a single or double acting actuator can be locked in any position.

Sealing is guaranteed by tempered, ground, tapered steel poppets, releasing is by venting the piloted openings "A" and "B" according to the valve pilot ratio. The valves can be mounted in any position and are protected externally by a zinc plating.

HYDRAULIC FEATURES

Max. Leakage (0 ÷ 5 drops/min)	0 ÷ 0.25 cm ³ /min
Hydraulic fluid	DIN 51524 Mineral oils
Fluid viscosity	10 ÷ 500 mm ² /s
Fluid temperature	-25°C ÷ 75°C
Ambient temperature	-25°C ÷ 60°C
Max. contamin. level class with filter	ISO 4406:1999 - class 19/17/14

5

Code	C	Flow max (l/min)	Pressure max (bar)	D (mm)	E (mm)	F (mm)	G (mm)	H (mm)	L (mm)	M (mm)	N (mm)	P (mm)	R (mm)	Weight (kg)	Pilot ratio
VBPSA0400	1/4 BSP	20	350	30	60	20	27	45	6.5	9	30	117	70	0.76	1:4
VBPSA0600	3/8 BSP	25	350	30	60	20	27	45	6.5	9	30	117	70	0.72	1:4
VBPSA0918	9/16-18 UNF	20	350	30	60	30.5	30.5	45	6.5	9	30	131	70	0.72	1:4
VBPSA0800	1/2 BSP	45	300	40	75	35	42	60	8	17	40	170	90	1.65	1:4
VBPSA1200	3/4 BSP	85	280	60	104	46	46	70	9	16	50	212	120	3.10	1:3.6
VBPDA0400	1/4 BSP	20	350	30	60	27	27	45	6.5	9	30	124	70	0.80	1:4
VBPDA0600	3/8 BSP	25	350	30	60	27	27	45	6.5	9	30	124	70	0.75	1:4
VBPDA0918	9/16-18 UNF	20	350	30	60	30.5	30.5	45	6.5	9	30	131	70	0.75	1:4
VBPDA0800	1/2 BSP	45	300	40	75	42	42	60	8	17	40	174	90	1.78	1:4
VBPDA1200	3/4 BSP	85	280	60	104	46	46	70	9	16	50	212	120	3.25	1:3.6

HYDRAULIC SYMBOLS

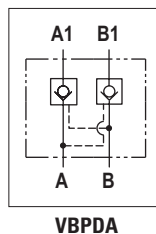
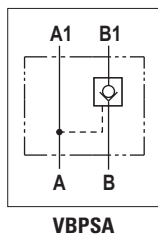

SERVICE EXAMPLE

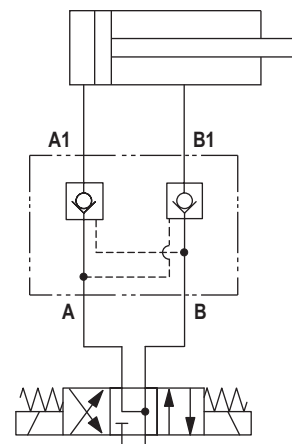

PRESSURE DROPS

5

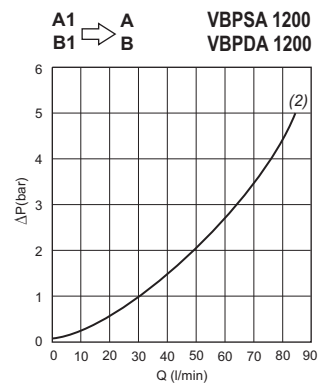
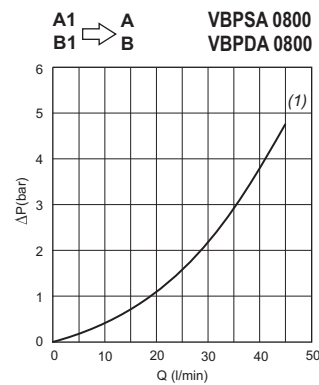
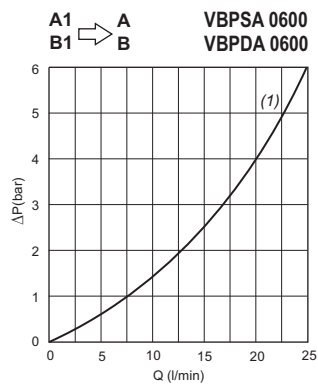
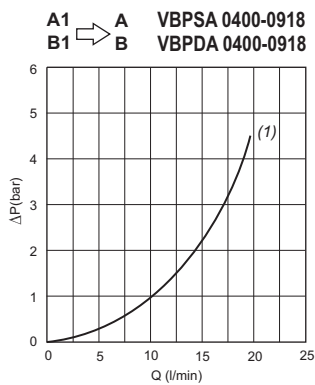
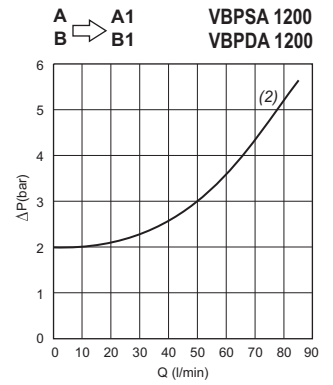
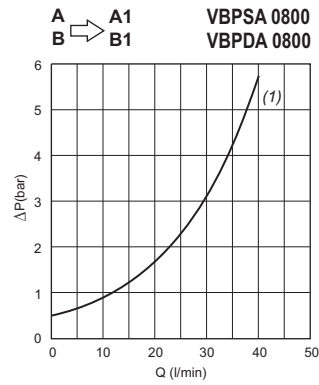
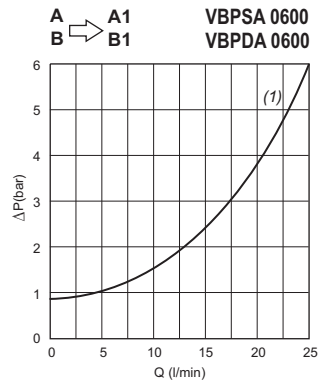
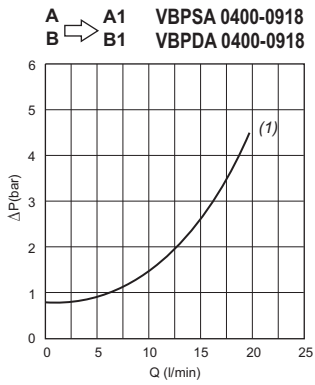

(1) Fluid used: mineral based oil with viscosity 15 mm²/s at 40°C.
 (2) Fluid used: mineral based oil with viscosity 24 mm²/s at 50°C.

ORDERING CODE

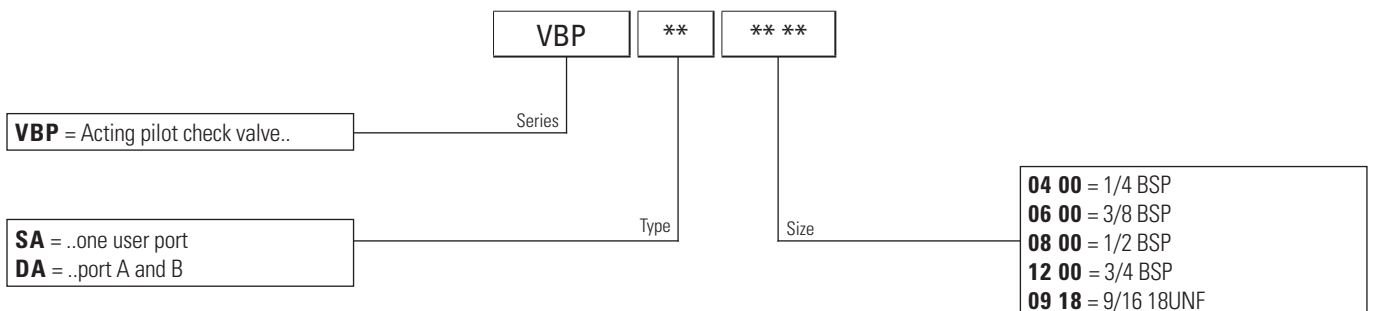

SINGLE AND DOUBLE ACTING PILOT CHECK VALVES-DIN 2353 PORTS - IN-LINE MOUNTING

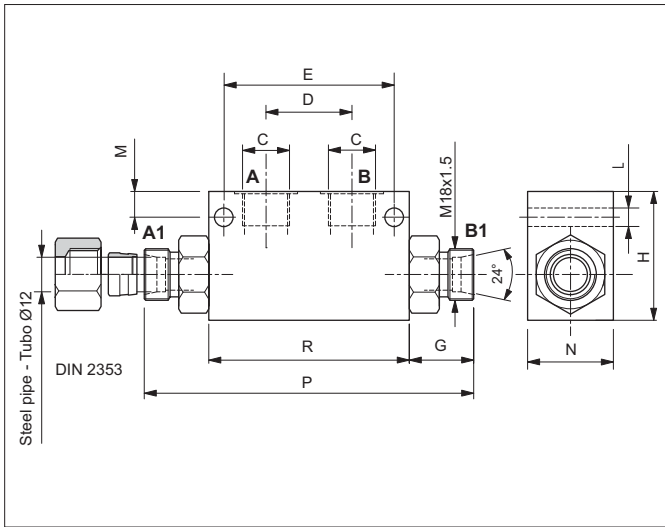

With the acting pilot check valves, a single or double acting actuator can be locked in any position.

Sealing is guaranteed by tempered, ground, tapered steel poppets, releasing is by venting the piloted openings "A" and "B" according to the valve pilot ratio. The valves can be mounted in any position and are protected externally by a zinc plating.

HYDRAULIC FEATURES

Max. Leakage (0 ÷ 5 drops/min)	0 ÷ 0.25 cm ³ /min
Hydraulic fluid	DIN 51524 Mineral oils
Fluid viscosity	10 ÷ 500 mm ² /s
Fluid temperature	-25°C ÷ 75°C
Ambient temperature	-25°C ÷ 60°C
Max. contamin. level class with filter	ISO 4406:1999 - class 19/17/14

5

Code	C	Flow max (l/min)	Pressure max (bar)	D (mm)	E (mm)	G (mm)	H (mm)	L (mm)	M (mm)	N (mm)	P (mm)	R (mm)	Weight (kg)	Pilot ratio
VBPSA0412	1/4 BSP	20	350	30	60	22.5	45	6.5	9	30	115	70	0.83	1:4
VBPSA0612	3/8 BSP	25	350	30	60	22.5	45	6.5	9	30	115	70	0.75	1:4
VBPDA0412	1/4 BSP	20	350	30	60	22.5	45	6.5	9	30	115	70	0.83	1:4
VBPDA0612	3/8 BSP	25	350	30	60	22.5	45	6.5	9	30	115	70	0.75	1:4

HYDRAULIC SYMBOLS

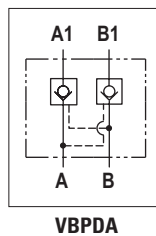
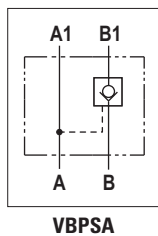

SERVICE EXAMPLE

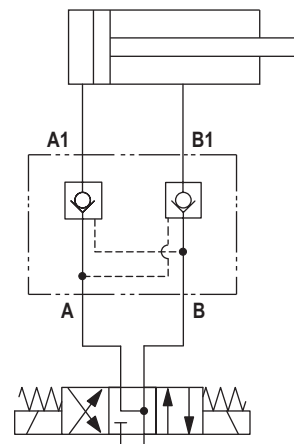

PRESSURE DROPS

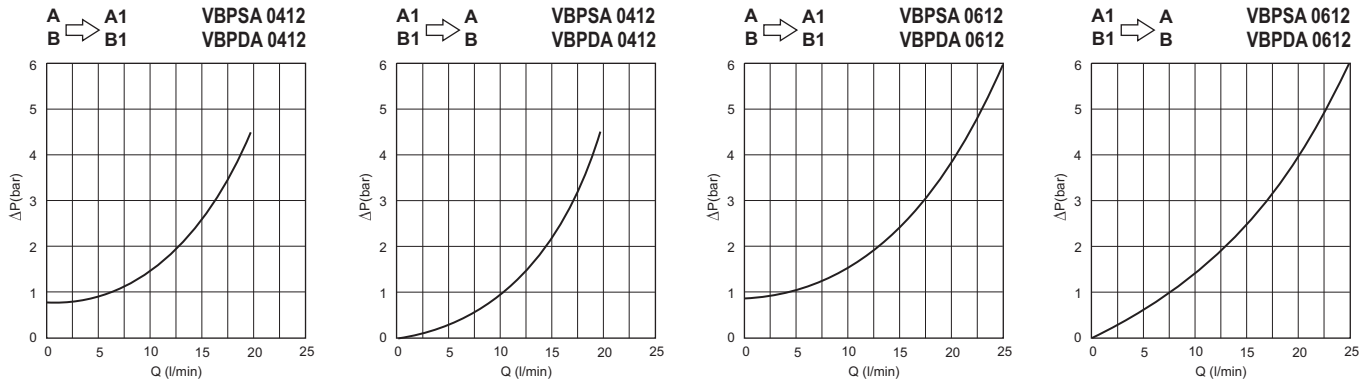

Fluid used: mineral based oil with viscosity 15 mm²/s at 40°C.

ACCESSORIES AND SPARE PARTS

	Q51435044	Copper Washer		OD050612L	DIN Banjo
	RF05060000	Hollow screw		1: E341L12 2: E342L12	Nut (spare) Cutting ring (spare)
	OT0506T12	Banjo		Assembly example with steel pipe Ø 12 mm DIN 2353	

ORDERING CODE

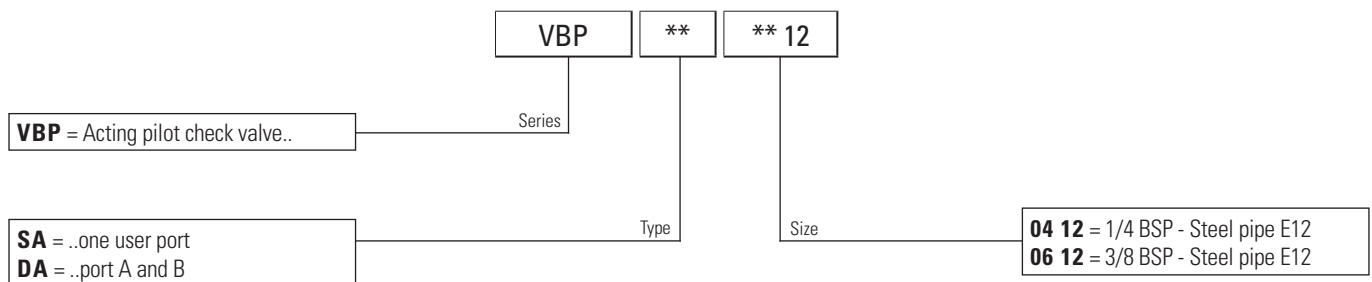

MANUAL AND PNEUMATIC OPERATED VALVES

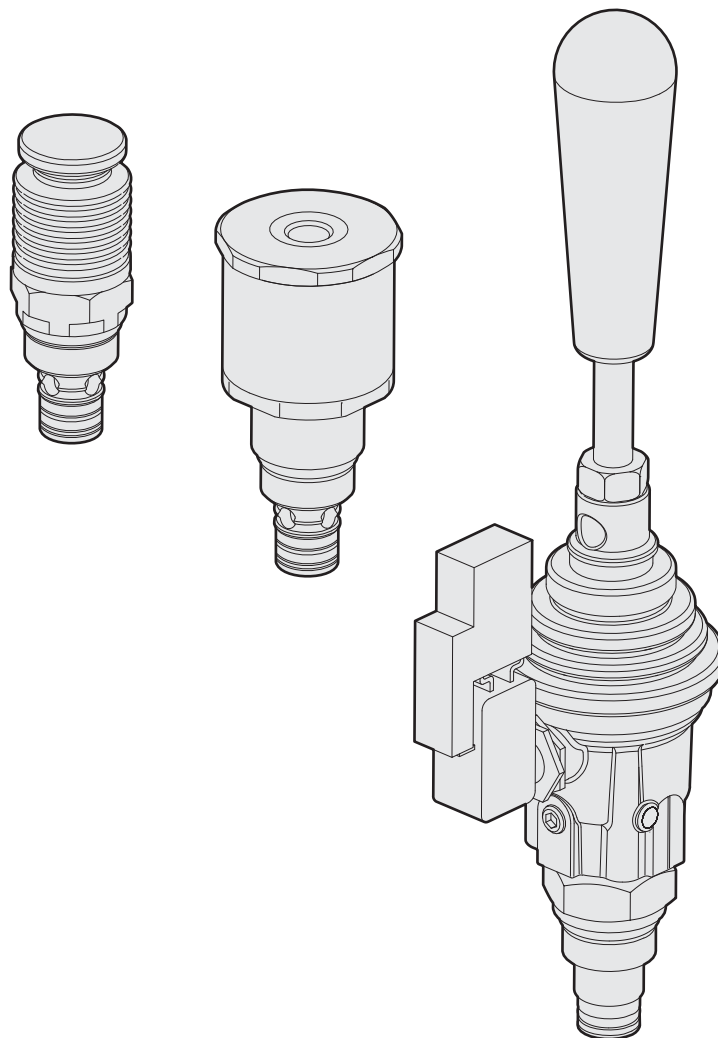

LEVER OPERATED VALVES

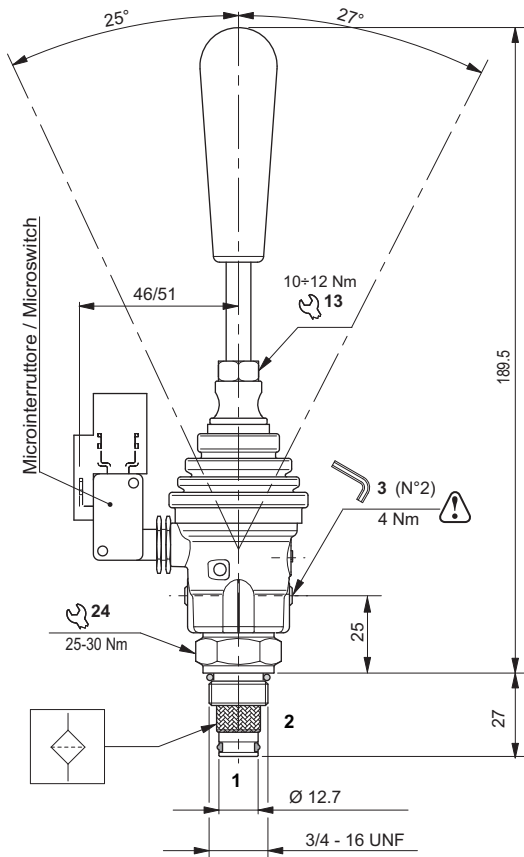

The direct acting, normally closed 2-way 2 position directional valve with manual control releases (load sensitive) pressure enabling fluid to flow through the valve from 2 to 1.

Tapered poppet is in tempered and ground steel.

Micro switch controlling a motor-driven pump relay supplied on request.

The lever body is in die-cast aluminium and the valve body in galvanised steel.

HYDRAULIC FEATURES

Max. working pressure	300 bar
Max. Flow	25 l/min
Max. Leakage (0 ÷ 5 drops/min)	0 ÷ 0.25 cm ³ /min
Working Temperature	-25°C ÷ 60°C
Hydraulic fluid	DIN 51524 Mineral oils
Fluid viscosity	10 ÷ 500 mm ² /s
Fluid temperature	-25°C ÷ 75°C
Max. contamin. level class with filter	ISO 4406:1999 - class 19/17/14
Tightening torque	25 ÷ 30 Nm
Weight	0.25 kg
Cavity (3/4 - 16 UNF)	CD018014 (See section 17)

Microswitch version

Mechanical life endurance at 250 Vac	10A (1E4) - 5A (5E4)
Protection degree with connector	IP40

00012003 Spare seals kit

HYDRAULIC SYMBOLS

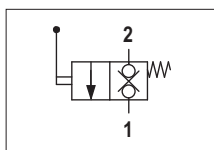

CMF04L
Without microswitch

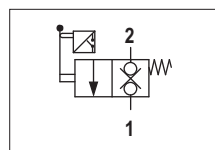

CMF04M
With microswitch

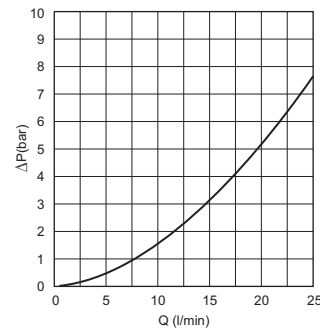

Fluid used: mineral based oil with viscosity
32 mm²/s at 40°C.

ORDERING CODE

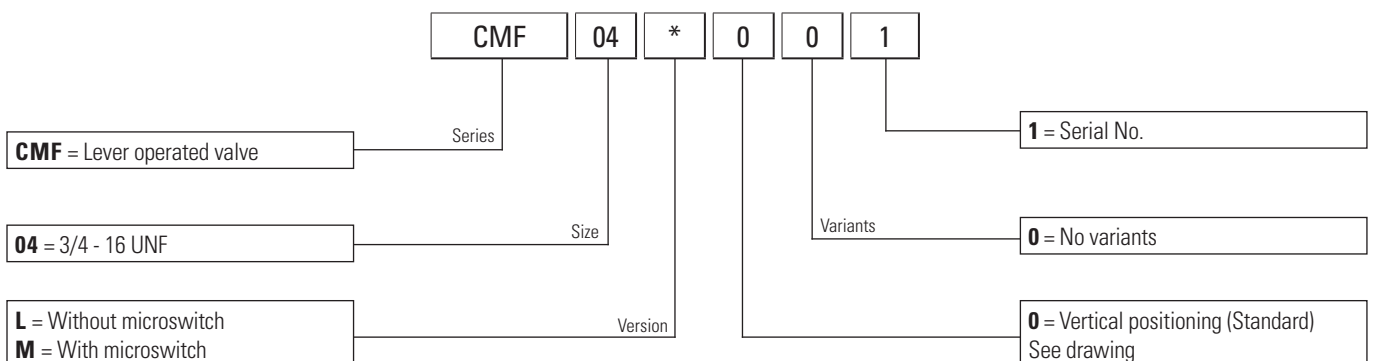

BUTTON OPERATED VALVES

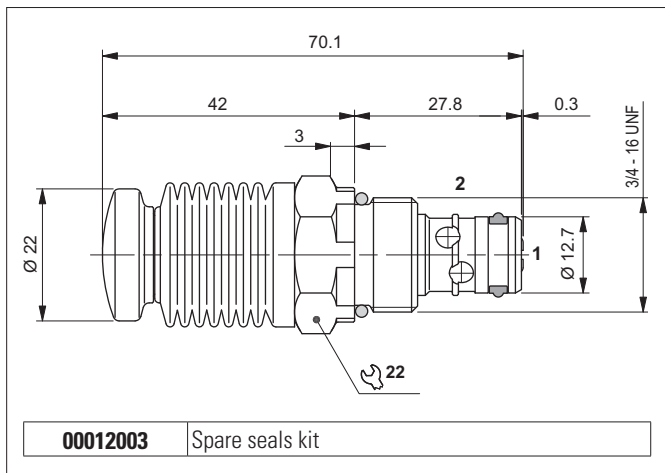

The direct acting, normally closed 2-way 2 position directional valve with manual control is used for emergencies. It is opened by pressing the button. The bi-directional tapered poppet is in tempered and ground steel. The valve body is in galvanised steel.

HYDRAULIC FEATURES

Max. working pressure	300 bar
Max. Flow	30 l/min
Max. Leakage (0 ÷ 20 drops/min)	0 ÷ 1 cm ³ /min
Hydraulic fluid	DIN 51524 Mineral oils
Fluid viscosity	10 ÷ 500 mm ² /s
Fluid temperature	-25°C ÷ 75°C
Ambient temperature	-25°C ÷ 60°C
Max. contamin. level class with filter	ISO 4406:1999 - class 19/17/14
Weight	0.107 kg
Tightening torque	25 ÷ 30 Nm
Cavity (3/4 - 16 UNF)	CD018006 (See section 17)

HYDRAULIC SYMBOL

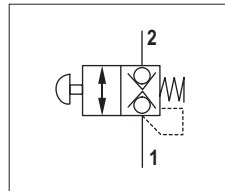

PRESSURE DROPS

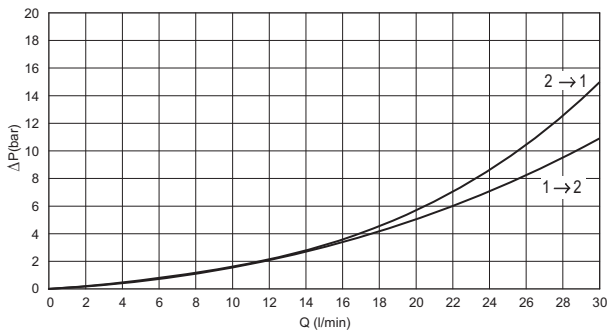

Fluid used: mineral based oil with viscosity 32 mm²/s at 40°C.

OPERAT. FORCE ON THE PUSH BUTTON

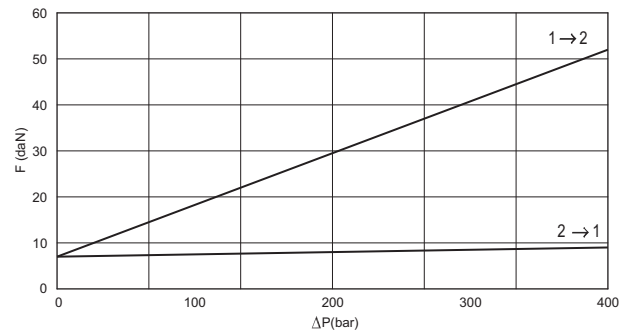

Fluid used: mineral based oil with viscosity 32 mm²/s at 40°C.

ORDERING CODE

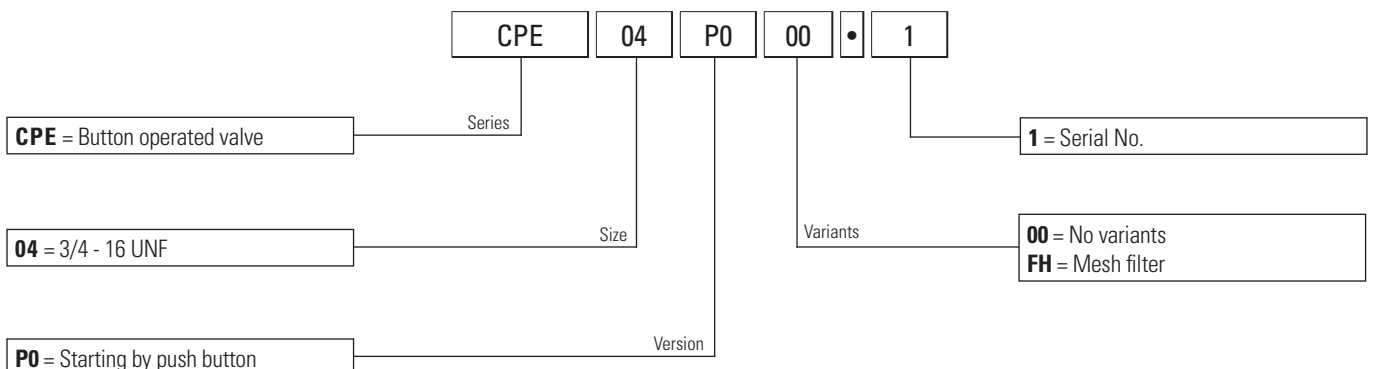

PNEUMATIC OPERATED VALVES

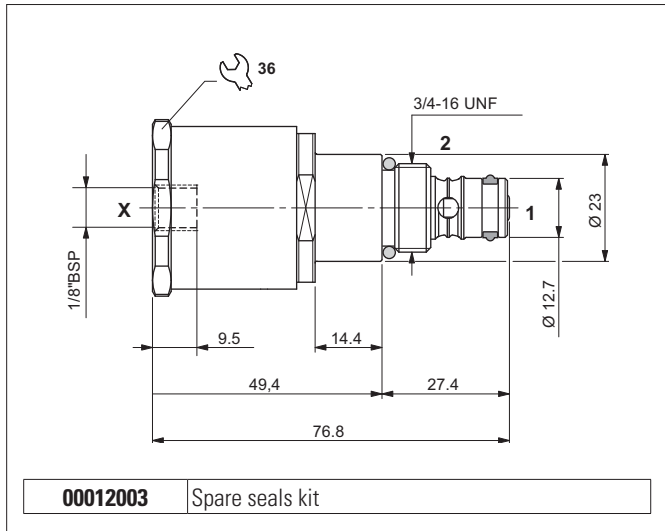

The direct acting, bi-directional way normally closed 2-way 2 position valve with pneumatic control releases the pressure enabling fluid to flow through the valve in both directions.

The bi-directional tapered poppet is in tempered and ground steel, released when the pilot branch X is connected to a pneumatic pressure signal. The valve body is in galvanised steel.

HYDRAULIC FEATURES

Max. working pressure	250 bar
Min. piloting pressure 1 → 2	5.5 bar
Min. piloting pressure 2 → 1	3.5 bar
Max. piloting pressure	20 bar
Max. Flow	30 l/min
Max. Leakage (0 ÷ 20 drops/min)	0 ÷ 1 cm ³ /min
Hydraulic fluid	DIN 51524 Mineral oils
Fluid viscosity	10 ÷ 500 mm ² /s
Fluid temperature	-25°C ÷ 75°C
Ambient temperature	-25°C ÷ 60°C
Max. contamin. level class with filter	ISO 4406:1999 - class 19/17/14
Weight	0.107 kg
Tightening torque	25 ÷ 30 Nm
Cavity (3/4 - 16 UNF)	CD018006 (See section 17)

6

HYDRAULIC SYMBOL

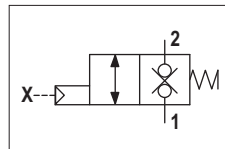

PRESSURE DROPS

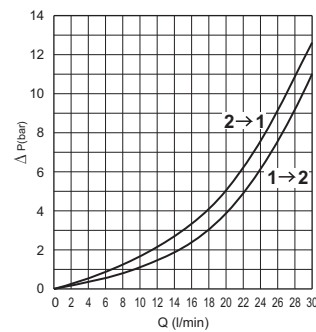

LIMITS OF USE

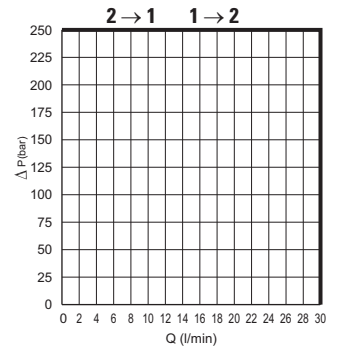

Fluid used: mineral based oil with viscosity 46 mm²/s at 40°C.

ORDERING CODE

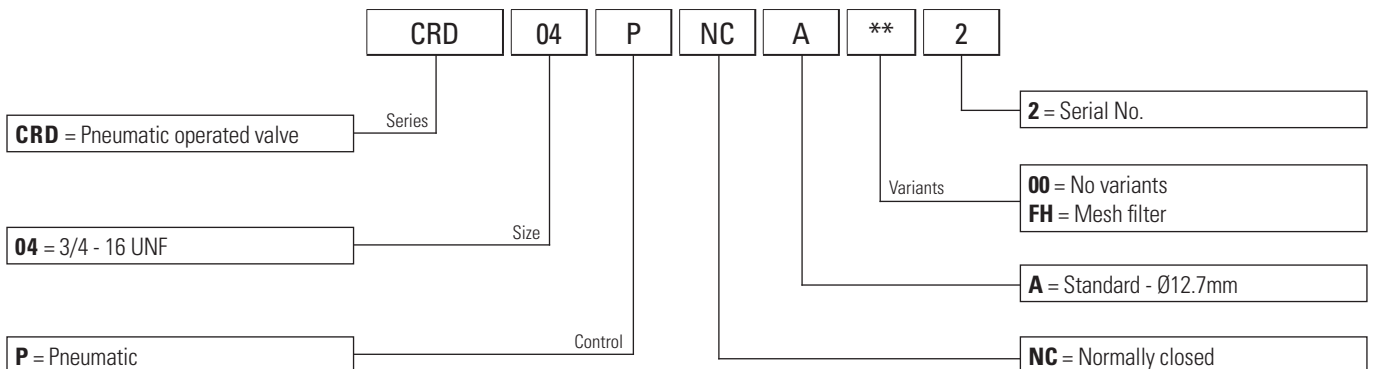

END-OFF STROKE VALVES

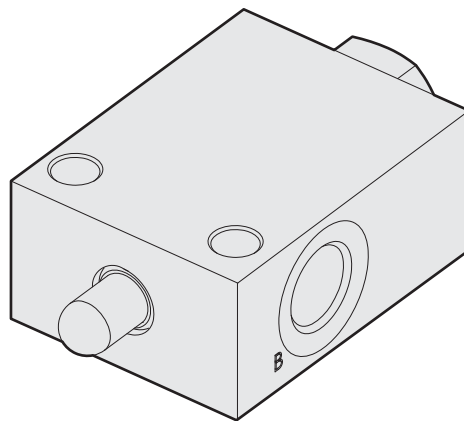

END-OFF STROKE VALVES - IN-LINE MOUNTING

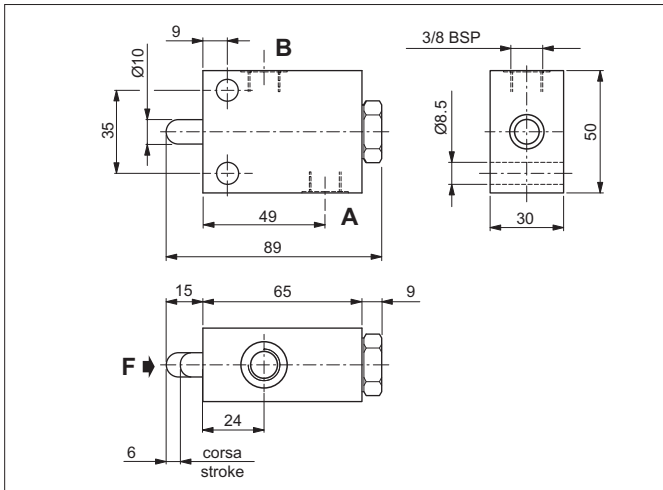

The direct acting normally closed 2-way 2-position directional valve with manual control is fitted on a branch to release the pressure; a pusher enables the fluid to pass through the valve from A to B. Tapered poppet is in tempered and ground steel. The valve body is in galvanised steel.

HYDRAULIC FEATURES

Max. working pressure	300 bar
Max. Flow	40 l/min
Max. Leakage (0 ÷ 5 drops/min)	0 ÷ 0.25 cm ³ /min
Max. mechanical push force (F) required at 300 bar	240 daN
Hydraulic fluid	DIN 51524 Mineral oils
Fluid viscosity	10 ÷ 500 mm ² /s
Fluid temperature	-25°C ÷ 75°C
Ambient temperature	-25°C ÷ 60°C
Max. contamin. level class with filter	ISO 4406:1999 - class 19/17/14
Weight	0.68 kg

7

HYDRAULIC SYMBOL

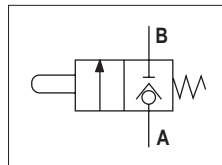

PRESSURE DROPS

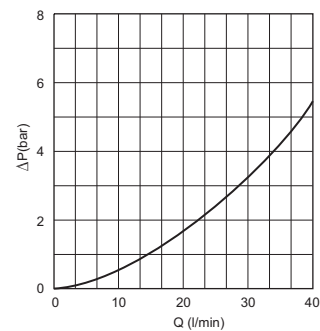

Fluid used: mineral based oil with viscosity 15 mm²/s at 40°C.

ORDERING CODE

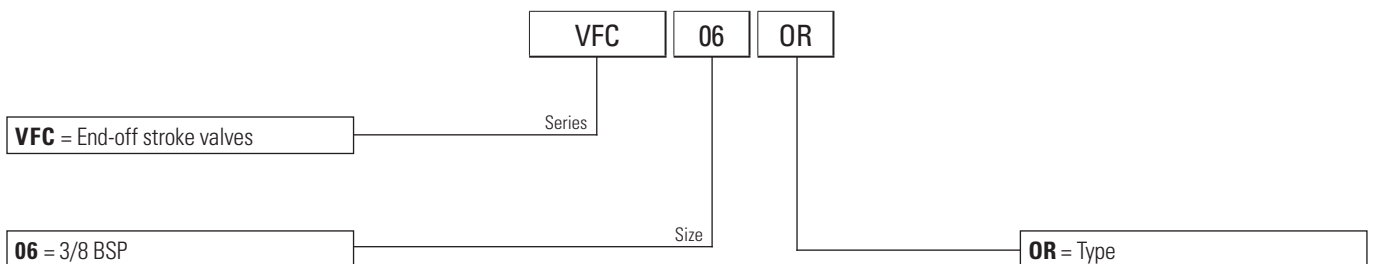

DECELERATION VALVES - IN-LINE MOUNTING

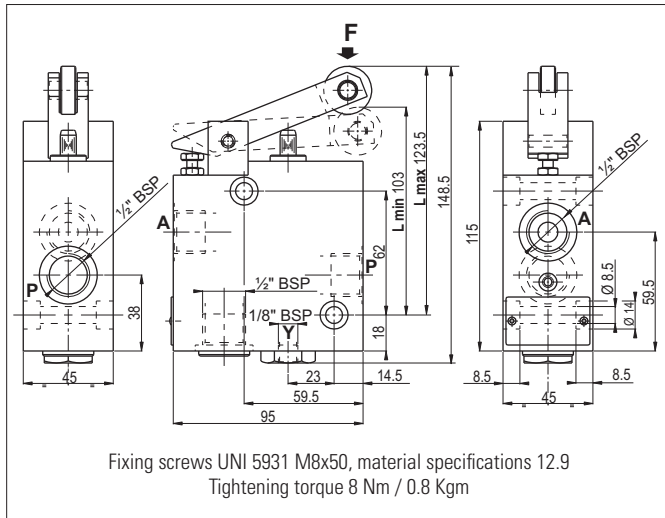

These valves are used as cam controlled unidirectional flow regulators. Normally mounted in line between actuator and directional valve for the displacement of carriages or slides, they enable cam controlled acceleration or deceleration of the moving mass. A special internal check valve allows free flow the opposite direction. To ensure correct functioning, connect "Y" to draining line.

HYDRAULIC FEATURES

Max. working pressure	180 bar
Max. Flow	40 l/min
Max. Leakage	0.06 l/min
Cam travel	See diagram
Max. mechanical push force (F)	100 N
Hydraulic fluid	DIN 51524 Mineral oils
Fluid viscosity	10 ÷ 500 mm ² /s
Fluid temperature	-25°C ÷ 75°C
Ambient temperature	-25°C ÷ 60°C
Max. contamin. level class with filter	ISO 4406:1999 - class 19/17/14
Weight	2.8 kg

HYDRAULIC SYMBOL

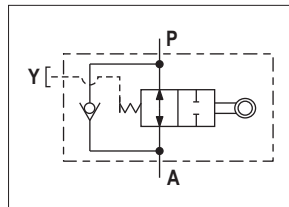

FLOW RATE / Lmin-Lmax

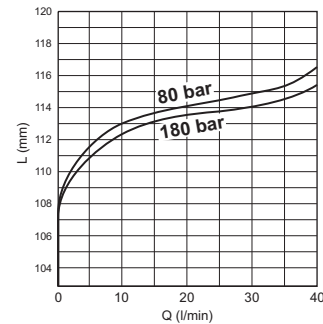

ORDERING CODE

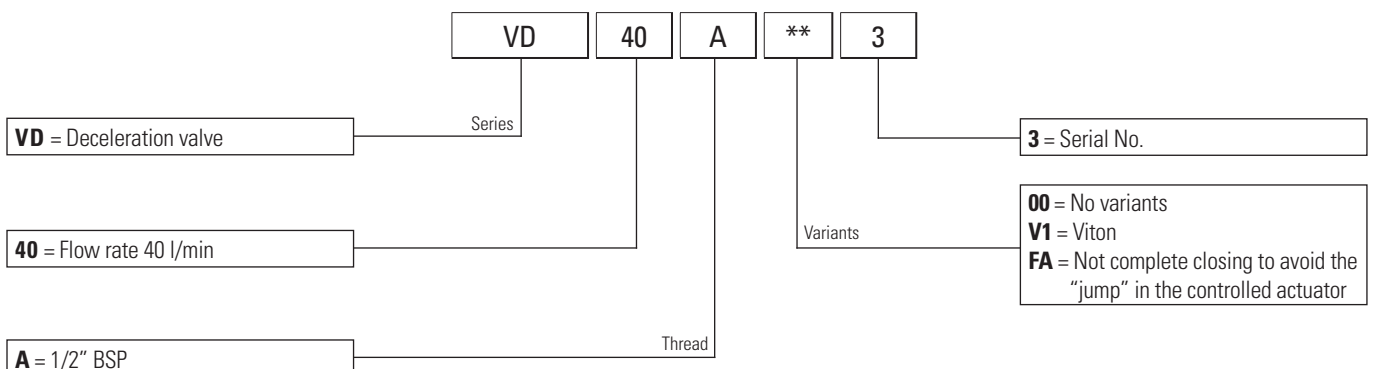

SOLENOID VALVES 2-WAY

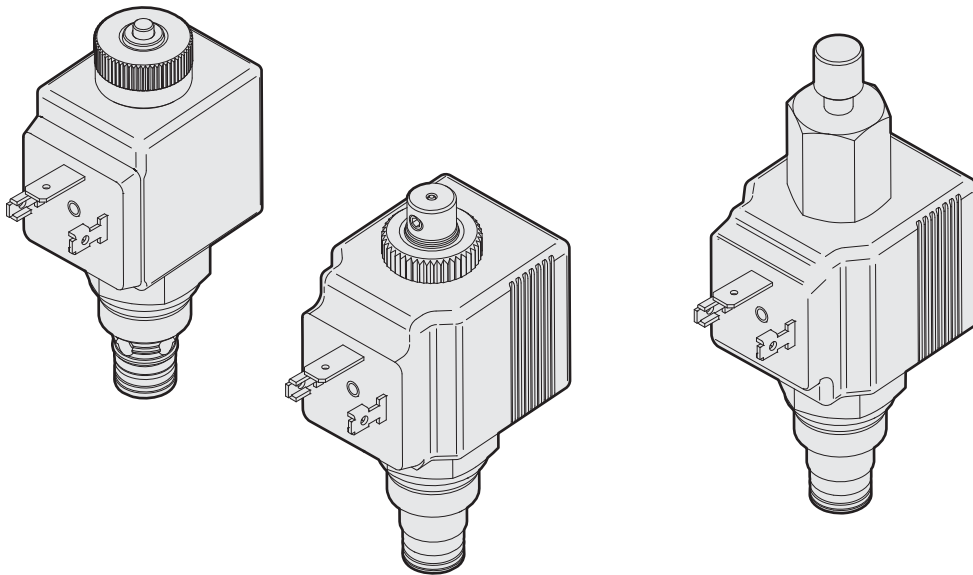

PILOTED OPERATED SOLENOID VALVE

Emergency (NC)

2.3 Corsa (Stroke) Ø10

CRP 04 18..
Cavity type "A"

Variants (NA)

19 max 7 Nm
3.3 Corsa (Stroke) Ø10 38.2 max

2.3 Corsa (Stroke) max 7 Nm
Ø20.3 Ø10 29.5
Removable cup

2.3 Corsa (Stroke) max 7 Nm
Ø21 Ø10 27

Emergency (NA)
Emergency (NA)

(*) 13.3 (NA)
13 (NC)

00012023	Spare seals kit
-----------------	-----------------

Reduction for cavity type "B"

V89B30000 Spare code

Connector to be ordered separately, see sect. 20

The pilot-operated electric 2-way 2-position directional valve is controlled electrically.
The tapered poppet is in tempered and ground steel.
Available in normally open (NA) or normally closed (NC) versions.

Valve	Free passage	Coil	Type
CRP..NA	2 → 1	DE-ENERGISED	Unidirectional
CRP..NC	2 → 1 1 → 2	ENERGISED DE-ENERGISED	
CRB..NA	1 → 2 2 → 1	DE-ENERGISED	Bidirectional
CRB..NC	1 → 2 2 → 1	ENERGISED / DE-ENERGISED ENERGISED	

AC normally closed valves (NC) can work also with coils in DC.
Normally open valves work with DC coils whereas RAC coils with a connector and incorporated rectifier must be used for AC applications.
The NC valve sleeve is in galvanised steel and the NA valve sleeve with nickel coated.

FEATURES

Max. pressure	300 bar (*)
Max. Flow	40 l/min
Max. Leakage (0 ÷ 10 drops/min)	0 ÷ 0.5 cm ³ /min
Max. excitation frequency	2 Hz
Duty cycle	100% ED
Hydraulic fluids	DIN 51524 Mineral oils
Fluid viscosity	10 ÷ 500 mm ² /s
Fluid temperature	-25°C ÷ 75°C
Ambient temperature	-25°C ÷ 60°C
Max. contamin. level class with filter	ISO 4406:1999 - class 19/17/14
Cartridge filter	280µm
Type of protection (in relation to the connection used)	IP65
Weight (with coil)	0.27 kg
Cartridge tightening torque	25 ÷ 30 Nm
Coil ring nut tightening torque	7 Nm
Emergency tightening torque	
Cavity standard "A" (3/4 - 16 UNF)	CD018006 (See section 17)
Cavity standard "A" + seat VSCOA**01	CD018009 (See section 17)
Cavity with reduction "B" (3/4 - 16 UNF)	CD018012 (See section 17)

(*) 80000 cycles at 300 bar / 200000 cycles at 210 bar

HYDRAULIC SYMBOLS

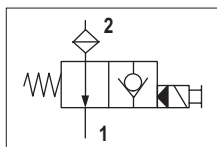

CRP - Normally open

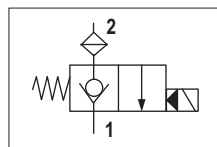

CRP - Normally closed

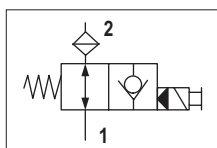

CRB - Normally open

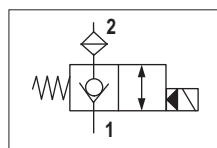

CRB - Normally closed

PRESSURE DROPS

LIMITS OF USE

CRB..NA (1 → 2 2 → 1)
CRP..NA (2 → 1)

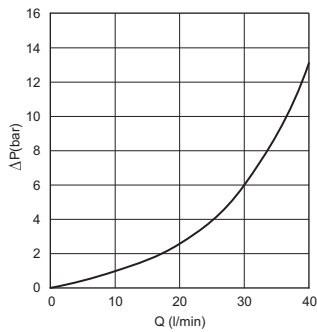

CRB..NC (2 → 1)
CRP..NC (2 → 1)

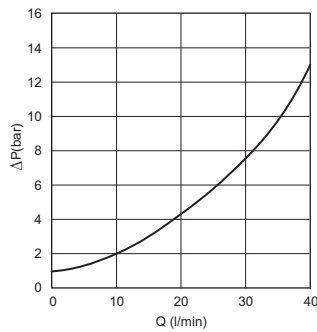

CRB..NC (1 → 2)
CRP..NC (1 → 2)

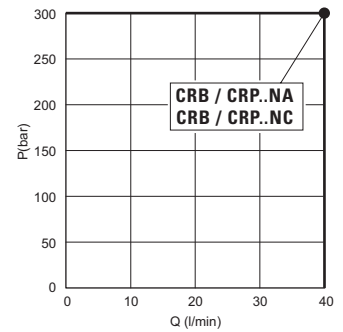
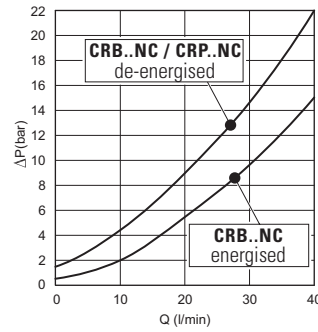

The tests were carried out with the solenoids at operating temperature, with a supply voltage 10% below nominal value and with a 40°C fluid temperature. The fluid used is a mineral oil with viscosity of 46 mm²/s at 40°C.

ORDERING CODE

	CR*	04	18	**	*	*	*	**	*																
	Series	Size	Coil	Version	Seat size	Version	Voltage	Variants																	
<p>CRB = Piloted solenoid valve bidirectional</p> <p>CRP = Piloted solenoid valve unidirectional</p>		<p>04 = 3/4 - 16 UNF</p>	<p>18 = 18W dc (NA-NC) - C30</p>	<p>NA = Normally open (solo con bobine DC o RAC)</p> <p>NC = Normally closed</p>	<p>A = Standard - Ø 12.7 mm</p> <p>B = With reduction - Ø 15.9 mm</p>	<p>S = Without emergency (NC)</p> <p>E = With emergency (NA-NC)</p>		<p>00 = No variants</p> <p>P4 = Push button Emergency with removable protection (..NA)</p> <p>P3 = Rotary Emergency (..NA)</p> <p>E9 = Push button Emergency direct control (..NA)</p> <p>SF = Without cartridge filter</p> <p>FK = With flying leads 600 mm (1)</p> <p>CX = Deutsch connection with bidirectional diode (2)</p> <p><i>Connector to be ordered separately, see sect. 20</i></p>	<p>1 = CRB - Serial No.</p> <p>3 = CRP - Serial No.</p>																
								<table border="1" style="width: 100%; border-collapse: collapse;"> <thead> <tr> <th style="text-align: left;">DC 18W (C30)</th> <th style="text-align: left;">AC 18W (C30) (7)</th> </tr> </thead> <tbody> <tr> <td>L = 12 VDC</td> <td>A = 24 VAC 50 Hz</td> </tr> <tr> <td>M = 24 VDC</td> <td>J = 115 VAC 50 Hz</td> </tr> <tr> <td>N = 48 VDC</td> <td>I = 230 VAC 50 Hz</td> </tr> <tr> <td>2 = 21.6 VDC RAC (3)</td> <td>F = 24 VAC 60 Hz</td> </tr> <tr> <td>Z = 102 VDC RAC (4)</td> <td>C = 110 VAC 60 Hz</td> </tr> <tr> <td>X = 205 VDC RAC (5)</td> <td>D = 220 VAC 60 Hz</td> </tr> <tr> <td>W = Without coil (6)</td> <td>K = Without coil (6-8)</td> </tr> </tbody> </table> <p><i>Coils technical data, see sect. 19</i></p>	DC 18W (C30)	AC 18W (C30) (7)	L = 12 VDC	A = 24 VAC 50 Hz	M = 24 VDC	J = 115 VAC 50 Hz	N = 48 VDC	I = 230 VAC 50 Hz	2 = 21.6 VDC RAC (3)	F = 24 VAC 60 Hz	Z = 102 VDC RAC (4)	C = 110 VAC 60 Hz	X = 205 VDC RAC (5)	D = 220 VAC 60 Hz	W = Without coil (6)	K = Without coil (6-8)	
DC 18W (C30)	AC 18W (C30) (7)																								
L = 12 VDC	A = 24 VAC 50 Hz																								
M = 24 VDC	J = 115 VAC 50 Hz																								
N = 48 VDC	I = 230 VAC 50 Hz																								
2 = 21.6 VDC RAC (3)	F = 24 VAC 60 Hz																								
Z = 102 VDC RAC (4)	C = 110 VAC 60 Hz																								
X = 205 VDC RAC (5)	D = 220 VAC 60 Hz																								
W = Without coil (6)	K = Without coil (6-8)																								

<p>(1) Only voltages 12 VDC - 24 VDC</p> <p>(2) Only voltages 12 VDC - 24 VDC</p> <p>(3) With rectifier: 24 VAC/50-60Hz</p> <p>(4) With rectifier: 115 VAC/50Hz - 120VAC/60Hz</p>	<p>(5) With rectifier: 230 VAC/50Hz - 240VAC/60Hz</p> <p>(6) Performance are guaranteed only using valves completed with BFP coil</p> <p>(7) Only for NC valves</p> <p>(8) Tested for working in AC and DC</p>
---	--

HIGH PRESSURE PILOTED OPERATED SOLENOID VALVE

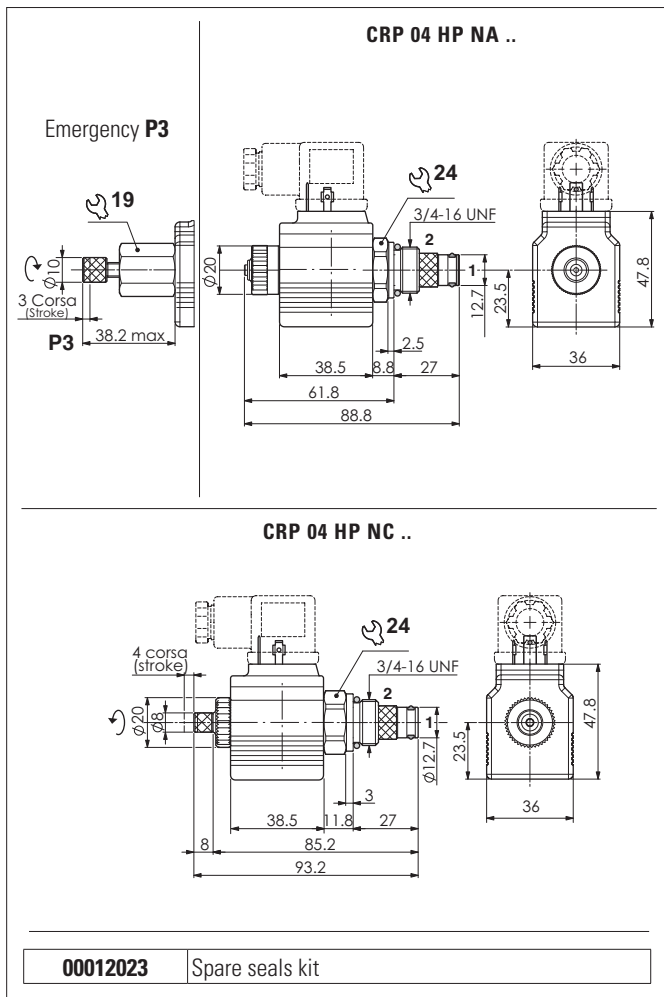

Connector to be ordered separately, see sect. 20

The pilot-operated electric 2-way 2-position directional valve is controlled electrically. For high pressures.

The tapered poppet is in tempered and ground steel.

Available in normally open (NA) or normally closed (NC) versions.

- NA, free passage from 2 to 1 with de-energised coil.
- NC, free passage from 2 to 1 with energised coil or from 1 to 2 with de-energised coil.

The valves work with DC coils whereas RAC coils with a connector with incorporated rectifier must be used for AC applications.

The sleeve is in galvanised steel.

FEATURES

Max. pressure	370 bar
Max. Flow	30 l/min
Max. Leakage (0 ÷ 10 drops/min)	0 ÷ 0.5 cm ³ /min
Max. excitation frequency	2 Hz
Duty cycle	100% ED
Hydraulic fluids	DIN 51524 Mineral oils
Fluid viscosity	10 ÷ 500 mm ² /s
Fluid temperature	-25°C ÷ 75°C
Ambient temperature	-25°C ÷ 60°C
Max. contamin. level class with filter	ISO 4406:1999 - class 19/17/14
Cartridge filter	280µm
Type of protection (in relation to the connection used)	IP65
Weight (with coil)	0.35 kg
Cartridge tightening torque	25 ÷ 30 Nm
Coil ring nut tightening torque	7 Nm
Cavity (3/4 - 16 UNF)	CD018006 (See section 17)

HYDRAULIC SYMBOLS

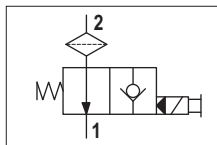

Normally open

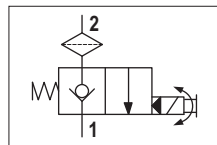

Normally closed

PRESSURE DROPS

CRP 04 HP NC.

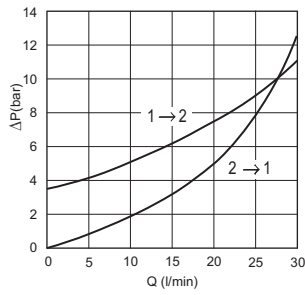

CRP 04 HP NA.

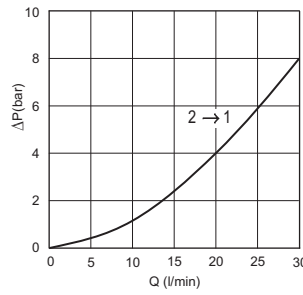

LIMITS OF USE

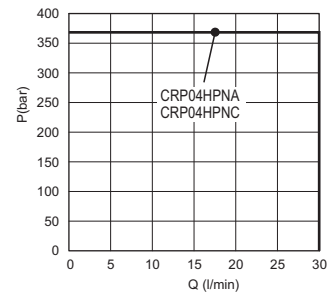

1 → 2 Only with coil not energised

The tests were carried out with the solenoids at operating temperature, with a supply voltage 10% below nominal value and with a 40°C fluid temperature. The fluid used is a mineral oil with viscosity of 46 mm²/s at 40°C.

ORDERING CODE

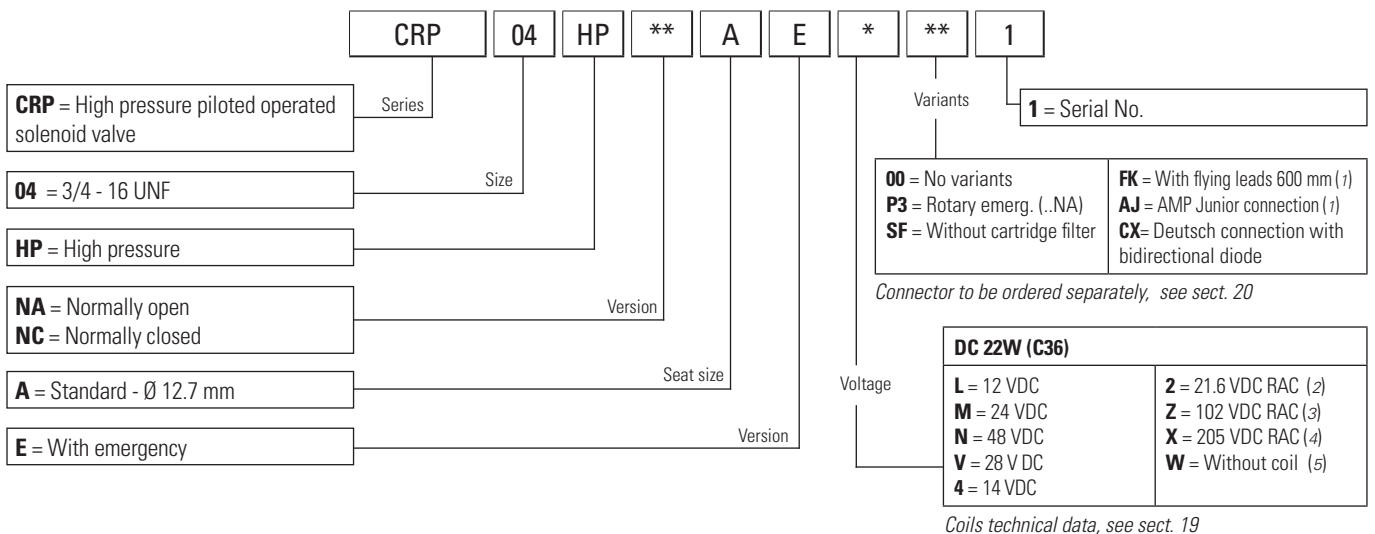

(1) Only voltages 12 VDC - 24 VDC

(2) With rectifier: 24 VAC/50-60Hz

(3) With rectifier: 115 VAC/50Hz - 120 VAC/60Hz

(4) With rectifier: 230 VAC/50Hz - 240 VAC/60Hz

(5) Performance are guaranteed only using valves completed with BFP coil

DIRECT OPERATED SOLENOID VALVE

Variants

CRD 04 18 NC ...
18W coil version

Emergenza standard
Standard emergency

24

3/4 - 16 UNF

2

1

20.5

42

30

38.6

13.3

27.4

2.5

Ø12.7

66.6

94

Variants

CRD 04 22 NC ...
22W coil version

Emergenza standard
Standard emergency

24

3/4 - 16 UNF

2

1

23.5

47.8

36

38.5

13.3

27.4

2.5

Ø12.7

66.6

94

Variants

CRD 04 NC ...
30W coil version

Emergenza standard
Standard emergency

24

3/4 - 16 UNF

2

1

45.5

45.5

61

27.9

Ø12.7

116.3

5

3

Flux	Emergency Force (F)
2 → 1	10N
1 → 2	10 + (2,5 x p) N

p = used pressure (bar)

00012023	Spare seals kit CRD0418NC - CRD0422NC
00012037	Spare seals kit CRD04NC

The direct acting, normally closed 2-way 2 position bi-directional electric control valve releases pressure and enables fluid to flow through the valve in both directions.

The bi-directional tapered poppet is in tempered and ground steel.

The valves work with DC coils whereas RAC coils with a connector with incorporated rectifier must be used for AC applications.

CRD0418NC - CRD0422NC: nickel-plated steel sleeve.

CRD04NC: phosphate-coating steel sleeve.

FEATURES

Max. pressure - see note (*)	CRD 04 22 NC = 300 bar CRD 04 18 NC = 210 bar CRD 04 NC = 250 bar
Max. Flow	CRD 04 22 NC /18 NC = 15 l/min CRD 04 NC = 30 l/min
Max. excitation frequency	2 Hz
Duty cycle	100% ED
Max. Leakage (0 ÷ 20 drops/min)	0 ÷ 1 cm ³ /min
Hydraulic fluids	DIN 51524 Mineral oils
Fluid viscosity	10 ÷ 500 mm ² /s
Fluid temperature	-25°C ÷ 75°C
Ambient temperature	-25°C ÷ 60°C
Max. contamin. level class with filter	ISO 4406:1999 - class 19/17/14
Cartridge filter	280µm
Type of protection (in relation to the connection used)	IP65
Weight (with coil)	CRD 04 18 NC = 0.27 kg CRD 04 22 NC = 0.35 kg CRD 04 NC = 0.63 kg
Cartridge tightening torque	25 ÷ 30 Nm
Coil ring nut tightening torque Emergency tightening torque	7 Nm
Cavity standard "A" (3/4 - 16 UNF)	CD018006 (See section 17)
Cavity with reduction "B" (3/4 - 16 UNF)	CD018012 (See section 17)

HYDRAULIC SYMBOLS

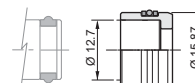
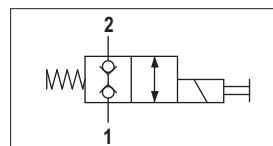

Reduction for cavity type "B"

V89B30000 Spare code

*** Max. pressure with reduction:**

Unidirectional 2 → 1 = 300 bar
Bidirectional 2 → 1 and 1 → 2 = 210 bar

Connector to be ordered separately, see sect. 20

PRESSURE DROPS

18W / 22W

A = 2 → 1
B = 1 → 2

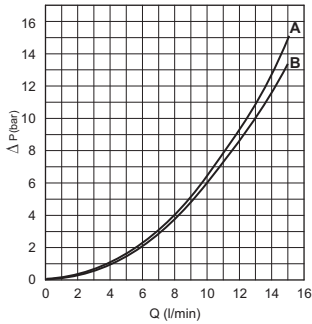

30W

G = 2 → 1
H = 1 → 2

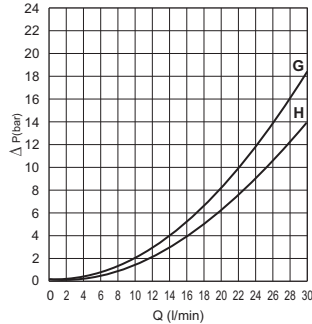

22W

C = 2 → 1
D = 1 → 2

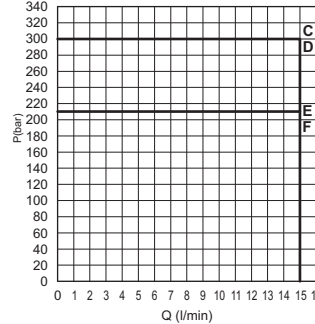

18W

E = 2 → 1
F = 1 → 2

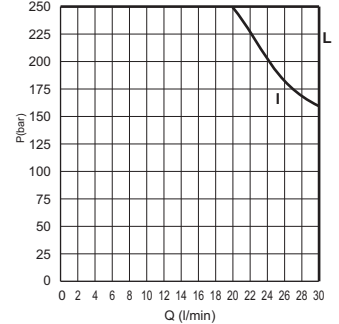

The tests were carried out with the solenoids at operating temperature, with a supply voltage 10% below nominal value and with a 40°C fluid temperature. The fluid used is a mineral oil with viscosity of 46 mm²/s at 40°C.

ORDERING CODE

	CRD	04	**	NC	*	*	*	**	*		
	Series	Size	Coil	Version	Seat size	Version	Voltage	Variants			
CRD = Direct operated solenoid valve		04 = 3/4 - 16 UNF	18 = 18W (C30) 22 = 22W (C36) 00 = Without coil (7)	NC = Normally closed	A = Standard - Ø 12.7 mm B = With reduction - Ø 15.9 mm	E = With emergency Omit for 30W version (D12)		<ul style="list-style-type: none"> 00 = No variants E1 = Rubber emergency (30W) P1 = Rotary emergency (30W) P3 = Rotary emergency (18W/22W) P4 = Push button Emergency with removable protection E9 = Push button Emergency direct control FY = Emergency P3 + FH (18W/22W) FH = Cartridge filter PJ = FH + P4 emergency FK = With flying leads 600 mm (1) AJ = AMP Junior connection (2) CX = Deutsch connection with bidirectional diode <p><i>Connector to be ordered separately, see sect. 20</i></p>	<table border="1" style="width: 100%; border-collapse: collapse;"> <tr> <td style="width: 50%;">2 = Serial No. CRD 04 18 NC.. CRD 04 22 NC.. CRD 04 00 NC..</td> <td style="width: 50%;">1 = Serial No. CRD 04 NC..</td> </tr> </table>	2 = Serial No. CRD 04 18 NC.. CRD 04 22 NC.. CRD 04 00 NC..	1 = Serial No. CRD 04 NC..
2 = Serial No. CRD 04 18 NC.. CRD 04 22 NC.. CRD 04 00 NC..	1 = Serial No. CRD 04 NC..										
							<table border="1" style="width: 100%; border-collapse: collapse;"> <tr> <td style="width: 50%;">DC 18W/22W (C30-C36) L = 12 VDC M = 24 VDC N = 48 VDC 2 = 21.6 VDC RAC (3) Z = 102 VDC RAC (4) X = 205 VDC RAC (5) W = Without coil (6)</td> <td style="width: 50%;">DC 30W (D12) L = 12 VDC M = 24 VDC W = Without coil (6)</td> </tr> </table> <p><i>Coils technical data, see sect. 19</i></p>	DC 18W/22W (C30-C36) L = 12 VDC M = 24 VDC N = 48 VDC 2 = 21.6 VDC RAC (3) Z = 102 VDC RAC (4) X = 205 VDC RAC (5) W = Without coil (6)	DC 30W (D12) L = 12 VDC M = 24 VDC W = Without coil (6)		
DC 18W/22W (C30-C36) L = 12 VDC M = 24 VDC N = 48 VDC 2 = 21.6 VDC RAC (3) Z = 102 VDC RAC (4) X = 205 VDC RAC (5) W = Without coil (6)	DC 30W (D12) L = 12 VDC M = 24 VDC W = Without coil (6)										

(7) Only voltages 12 VDC - 24 VDC and coils 18W/22W
 (2) Only voltages 12 VDC - 24 VDC and coil 22W
 (3) With rectifier: 24 VAC/50-60Hz
 (4) With rectifier: 115 VAC/50Hz - 120 VAC/60Hz
 (5) With rectifier: 230 VAC/50Hz - 240 VAC/60Hz
 (6) Performance are guaranteed only using valves completed with BFP coil

SOLENOID VALVES 2 WAY 2 POSITIONS

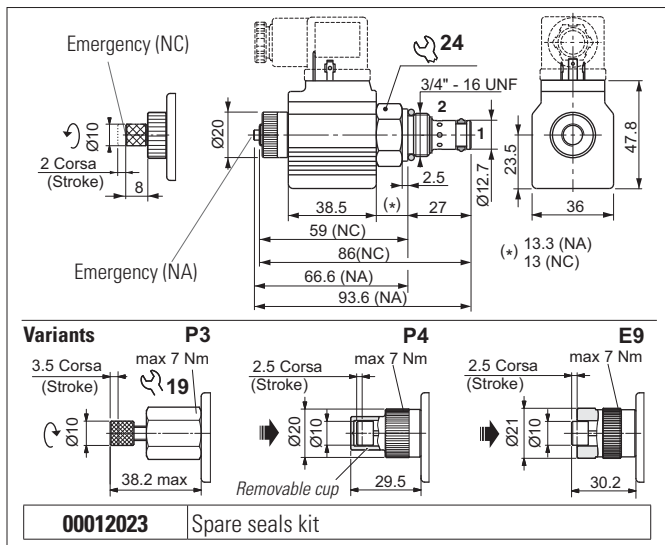

Connector to be ordered separately, see sect. 20

The electric valve is a 2-way 2-position bidirectional electrically controlled valve. Slight leakage is tolerated for this type of valve. Available in normally open (NA) or normally closed (NC) versions. The valves work with DC coils whereas RAC coils with a connector with incorporated rectifier must be used for AC applications. The sleeve is in galvanised steel (C2V0422NC..) or nickel-plated (C2V0422NA..). The plunger is in tempered and ground steel.

FEATURES

Max. pressure	250 bar
Max. Flow	12 l/min
Max. excitation frequency	2 Hz
Duty cycle	100% ED
Hydraulic fluids	DIN 51524 Mineral oils
Fluid viscosity	10 ÷ 500 mm ² /s
Fluid temperature	-25°C ÷ 75°C
Ambient temperature	-25°C ÷ 60°C
Max. contamin. level class with filter	ISO 4406:1999 - class 19/17/14
Type of protection (in relation to the connection used)	IP65
Weight (with coil)	0.30 kg
Cartridge tightening torque	25 ÷ 30 Nm
Coil ring nut tightening torque	7 Nm
Cavity (3/4 - 16 UNF)	CD018006 (See section 17)

8

HYDRAULIC SYMBOLS

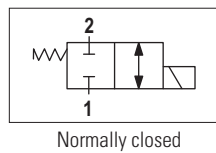
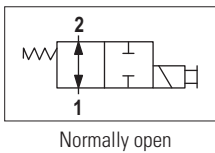

PRESSURE DROPS

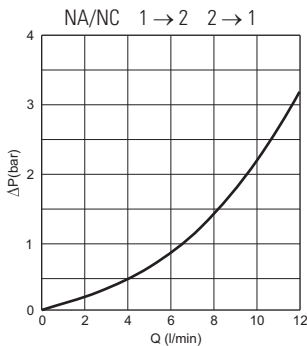

LIMIT OF USE

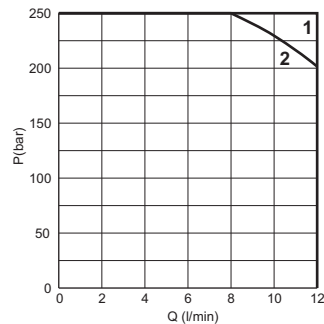

Limits of use

Flow	C2V04 NA	C2V04 NC
1 → 2	Curve 2	Curve 1
2 → 1	Curve 1	Curve 1

The tests were carried out with the 22W solenoids at operating temperature, with a supply voltage 10% below nominal valve and with a 40°C fluid temperature. The fluid used is a mineral oil with viscosity of 46 mm²/s at 40°C.

ORDERING CODE

C2V	04	22	**	A	*	*	00	2	2 = Serial No.
Series		Size		Coil		Version		Seat	
Emergency		Voltage		Variants		Voltage			

C2V = Solenoid valve 3 way / 2 positions

04 = 3/4 - 16 UNF

22 = 22W (C36)

NC = Normally closed
NA = Normally open

A = Ø 12.7 mm (standard)

S = Without emergency (NC)
E = With emergency (NA - NC)

00 = No variants
P3 = Rotary emerg.(..NA)
P4 = Push butt. emerg.(..NA)
E9 = Push butt. emerg.(..NA)

FK = With flying leads 600 mm (1)
AJ = AMP Junior connection (1)
CX = Deutsch connection with bidirectional diode

Connector to be ordered separately, see sect. 20

DC 22W (C36)

L = 12 VDC
M = 24 VDC
N = 48 VDC

2 = 21.6 VDC RAC (2)
Z = 102 VDC RAC (3)
X = 205 VDC RAC (4)
W = Without coil (5)

Coils technical data, see sect. 19

(1) Only voltages 12 VDC - 24 VDC
(2) With rectifier: 24 VAC/50-60Hz
(3) With rectifier: 115 VAC/50Hz - 120 VAC/60Hz

(4) With rectifier: 230 VAC/50Hz - 240 VAC/60Hz
(5) Performance are guaranteed only using valves completed with BFP coil

SOLENOID VALVES 3-4 WAY

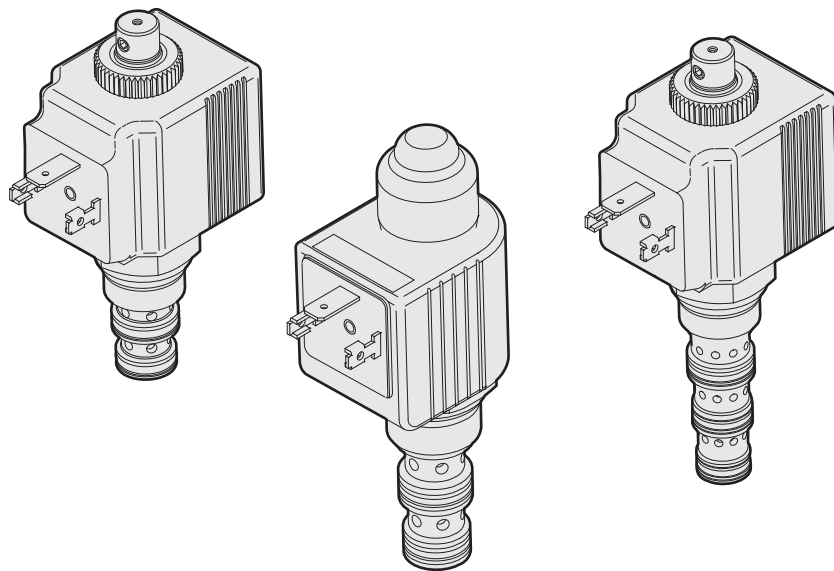

SOLENOID VALVES 3-WAY/2-POSITION

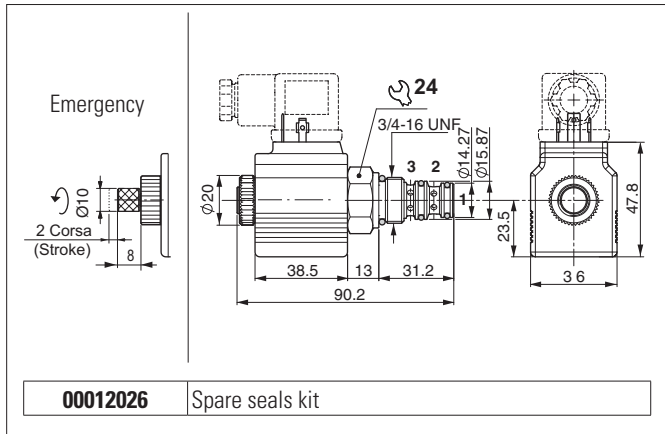

00012026 Spare seals kit

Connector to be ordered separately, see sect. 20

HYDRAULIC SYMBOL

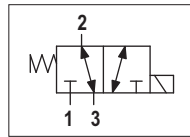

The electric valve is a 3-way 2-position directional electrically controlled valve. Slight leakage is tolerated for this type of valve. The valves work with DC coils whereas RAC coils with a connector with incorporated rectifier must be used for AC applications. The sleeve is in galvanised steel. The plunger is in tempered and ground steel.

HYDRAULIC FEATURES

Max. working pressure	210 bar
Max. Flow	12 l/min
Max. excitation frequency	2 Hz
Duty cycle	100% ED
Hydraulic fluid	DIN 51524 Mineral oils
Fluid viscosity	10 ÷ 500 mm ² /s
Fluid temperature	-25°C ÷ 75°C
Ambient temperature	-25°C ÷ 60°C
Max. contamin. level class with filter	ISO 4406:1999 - class 19/17/14
Type of protection (in relation to the connector used)	IP 65
Weight	0.30 kg
Cartridge tightening torque	25 ÷ 30 Nm
Coil ring nut tightening torque	7 Nm
Cavity (3/4 - 16 UNF)	CD018005 (See section 17)

9

PRESSURE DROPS

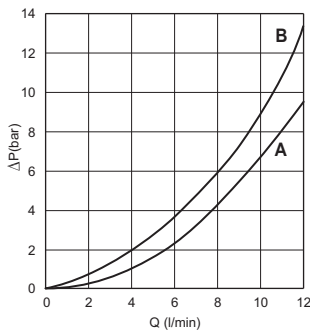

LIMIT OF USE

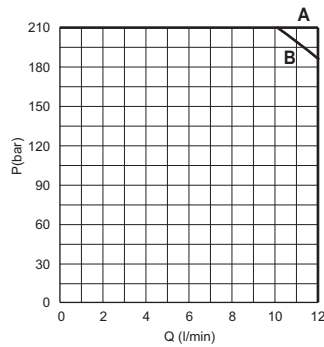

Flow	Pressure drops	Limit of use
1 → 2	A	A
2 → 1	A	A
2 → 3	B	B
3 → 2	B	B

Curve

The tests were carried out with the 22W solenoids at operating temperature, with a supply voltage 10% below nominal value and with a 40°C fluid temperature.

The fluid used is a mineral oil with viscosity of 46 mm²/s at 40°C.

ORDERING CODE

C3V = Solenoid valve 3 way / 2 positions	Series	04 = 3/4 - 16 UNF	Size	22 = 22W (C36)	Coil	1C = Hydraulic schema	Schema	C = Seat	Seat type	*	Version	*	Voltage	**	Variants	2 = Serial No.
S = Without emergency		E = With emergency											DC 22W (C36)			
													L = 12 VDC	Z = 21.6 VDC RAC (2)		
													M = 24 VDC	X = 102 VDC RAC (3)		
													N = 48 VDC	W = Without coil (5)		

Connector to be ordered separately, see sect. 20

Coils technical data, see sect. 19

(1) Only voltages 12 VDC - 24 VDC

(2) With rectifier: 24 VAC/50-60Hz

(3) With rectifier: 115 VAC/50Hz - 120 VAC/60Hz

(4) With rectifier: 230 VAC/50Hz - 240 VAC/60Hz

(5) Performance are guaranteed only using valves completed with BFP coil

SOLENOID VALVES 3-WAY/2-POSITION

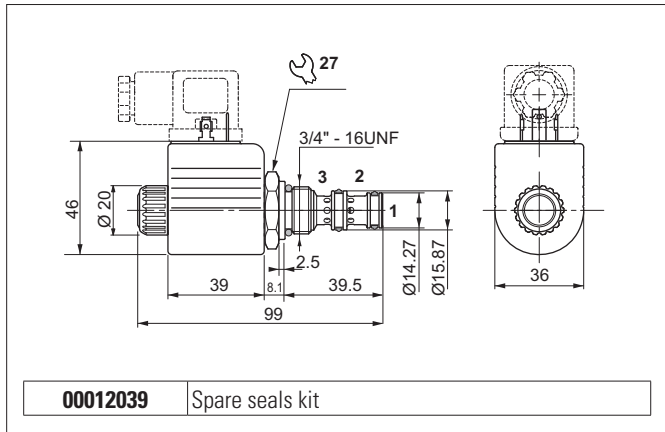

Connector to be ordered separately, see sect. 20

HYDRAULIC SYMBOL

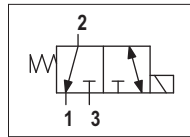

PRESSURE DROPS

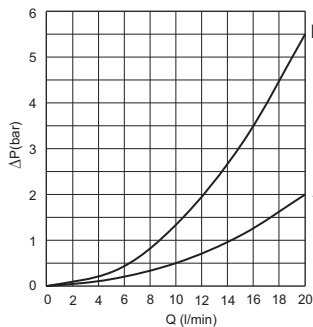

LIMIT OF USE

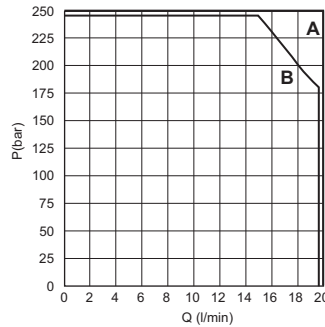

The electric valve is a 3-way 2-position directional electrically controlled valve.

Slight leakage is tolerated for this type of valve.

The valves work with DC coils whereas RAC coils with a connector with incorporated rectifier must be used for AC applications.

The sleeve is in phosphate steel. The plunger is in tempered and ground steel.

HYDRAULIC FEATURES

Max. working pressure	250 bar
Max. Flow	20 l/min
Max. excitation frequency	2 Hz
Duty cycle	100% ED
Hydraulic fluid	DIN 51524 Mineral oils
Fluid viscosity	10 ÷ 500 mm ² /s
Fluid temperature	-25°C ÷ 75°C
Ambient temperature	-25°C ÷ 50°C
Max. contamin. level class with filter	ISO 4406:1999 - class 19/17/14
Type of protection (in relation to the connector used)	IP 65
Weight	0.30 kg
Cartridge tightening torque	25 ÷ 30 Nm
Coil ring nut tightening torque	4.5 Nm
Cavity (3/4 - 16 UNF)	CD018003 (See section 17)

Flow	Pressure drops	Limit of use
2 → 1	A	A
2 → 3	B	A
3 → 2	B	B
Curve		

The tests were carried out with the 27W solenoids at operating temperature, with a supply voltage 10% below nominal value and with a 40°C fluid temperature.

The fluid used is a mineral oil with viscosity of 46 mm²/s at 40°C.

ORDERING CODE

C3V 04 27 1D D S * ** 2

- C3V** = Solenoid valve 3 way / 2 positions (Series)
- 04** = 3/4 - 16 UNF (Size)
- 27** = 27W (A09) (Coil)
- 1D** = Hydraulic schema (Schema)
- D** = Seat (Seat type)
- S** = Without emergency (Version)
- *** = Variants
- **** = Variants
- 2** = Serial No.

Variants:

- 00** = No variants
- FL** = Coil with flying leads (250 mm) (1)
- LD** = Coil with flying leads (130 mm) and integrated diode (1)
- AJ** = AMP Junior coil (1)
- CX** = Deutsch coil and integrated diode (1)

Connector to be ordered separately, see sect. 20

DC 27W (A09)

L = 12 VDC	Z = 102 VDC RAC (2)
M = 24 VDC	X = 205 VDC RAC (3)
N = 48 VDC	W = Without coil (4)
P = 110 VDC	

Coils technical data, see sect. 19

(1) Only voltages 12 VDC - 24 VDC
 (2) With rectifier: 115 VAC/50Hz - 120 VAC/60Hz

(3) With rectifier: 230 VAC/50Hz - 240 VAC/60Hz
 (4) Performance are guaranteed only using valves completed with BFP coil

SOLENOID VALVES 3 WAY 2 POSITIONS

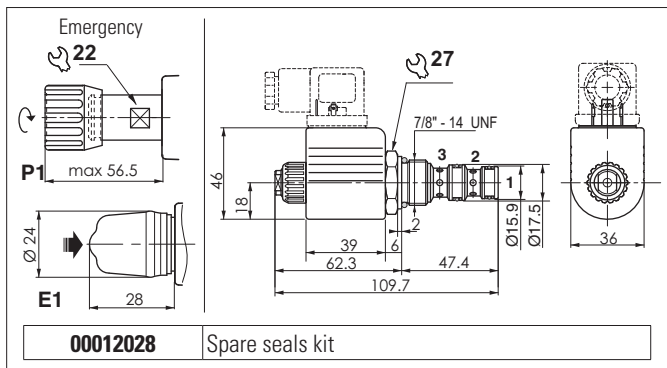

Connector to be ordered separately, see sect. 20

The electric valve is a 3-way 2-position directional electrically controlled valve.
Slight leakage is tolerated for this type of valve.
Available in 2 layouts.
The valves work with DC coils whereas RAC coils with a connector with incorporated rectifier must be used for AC applications.
The sleeve is in galvanised steel. The plunger is in tempered and ground steel.

HYDRAULIC FEATURES

Max. working pressure	250 bar
Max. Flow	20 l/min
Max. excitation frequency	2 Hz
Duty cycle	100% ED
Hydraulic fluid	DIN 51524 Mineral oils
Fluid viscosity	10 ÷ 500 mm ² /s
Fluid temperature	-25°C ÷ 75°C
Ambient temperature	-25°C ÷ 50°C
Max. contamin. level class with filter	ISO 4406:1999 - class 19/17/14
Type of protection (in relation to the connector used)	IP 65
Weight	0.37 kg
Cartridge tightening torque	45 ÷ 50 Nm
Emergency P1 tightening torque	6 ÷ 9 Nm
Coil ring nut tightening torque	4.5 Nm
Cavity (7/8 - 14 UNF)	CD019006 (See section 17)

SPOOL HYDRAULIC SCHEME

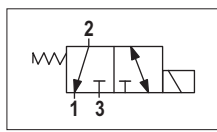

1D

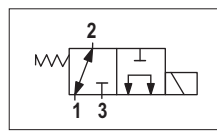

1E

PRESSURE DROPS

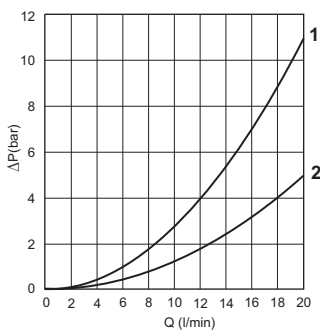

Spool type	Connections (pressure drops)					
	2→1	2→3	1→2	1→3	3→1	3→2
1D	2	1	—	—	—	1
1E	2	—	2	1	1	—

Curve No.

LIMIT OF USE

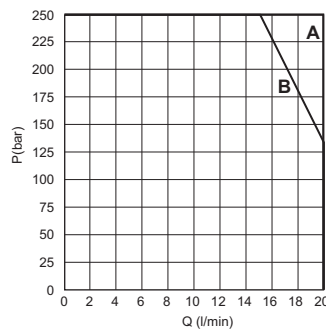

Spool type	Connections (limits of use)					
	2→1	2→3	1→2	1→3	3→1	3→2
1D	A	A	—	—	—	B
1E	A	—	B	B	A	—

Curve No.

The tests were carried out with the solenoids at operating temperature, with a supply voltage 10% below nominal value and with a 40°C fluid temperature.
The fluid used is a mineral oil with viscosity of 46 mm²/s at 40°C.

ORDERING CODE

C3V 03 ** E * * ** 1

- C3V** = Solenoid valve 3 way / 2 positions (Series)
- 03** = 27W Coil (A09) (Coil)
- **** = See "Spool scheme" (Spool)
- E** = Seat (Seat type)
- *** = Connection type
- *** = Voltage
- **** = Variants
- 1** = Serial No.

00 = No variants
E1 = Rubber emergency
P1 = Rotary emergency button

Connector to be ordered separately, see sect. 20

DC 27W (A09)

- L** = 12 VDC
- M** = 24 VDC
- N** = 48 VDC
- P** = 110 VDC
- Z** = 102 VDC RAC (2)
- X** = 205 VDC RAC (3)
- W** = Without coil (4)

Coils technical data, see sect. 19

(1) Only voltages 12 VDC - 24 VDC

(2) With rectifier: 115 VAC/50Hz - 120 VAC/60Hz

(3) With rectifier: 230 VAC/50Hz - 240 VAC/60Hz

(4) Performance are guaranteed only using valves completed with BFP coil

SOLENOID VALVES 4 WAY 2 POSITIONS

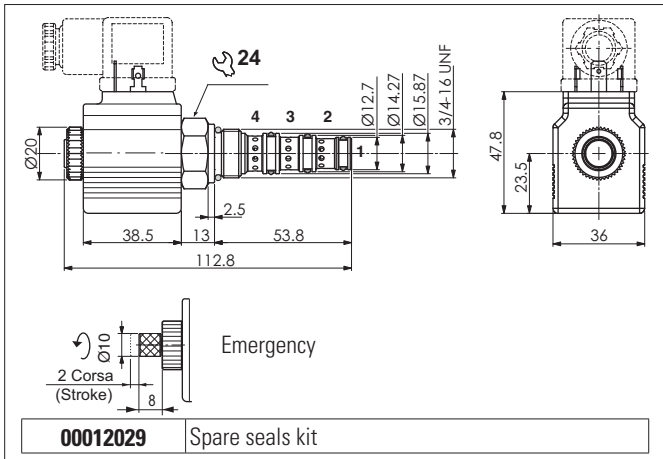

Connector to be ordered separately, see sect. 20

The electric valve is a 4-way 2-position directional electrically controlled valve. Slight leakage is tolerated for this type of valve. Available in 5 layouts. The valves work with DC coils whereas RAC coils with a connector with incorporated rectifier must be used for AC applications. The sleeve is in galvanised steel. The plunger is in tempered and ground steel.

HYDRAULIC FEATURES

Max. working pressure	250 bar
Max. Flow	18 l/min
Max. excitation frequency	2 Hz
Duty cycle	100% ED
Hydraulic fluid	DIN 51524 Mineral oils
Fluid viscosity	10 ÷ 500 mm ² /s
Fluid temperature	-25°C ÷ 75°C
Ambient temperature	-25°C ÷ 60°C
Max. contamin. level class with filter	ISO 4406:1999 - class 19/17/14
Type of protection (in relation to the connector used)	IP 65
Weight	0.34 kg
Cartridge tightening torque	25 ÷ 30 Nm
Emergency P1 tightening torque	7 Nm
Cavity (3/4 - 16 UNF)	CD018001 (See section 17)

PRESSURE DROPS

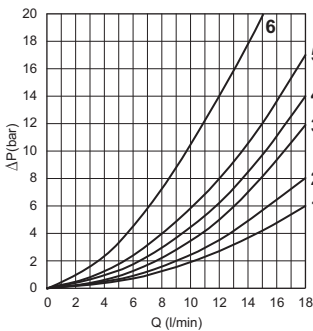

LIMIT OF USE

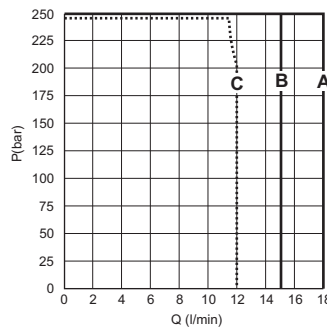

Spool type	Connections (pressure drops)			
	3→1	3→2	3→4	2→1
D	—	5	5	3
C	—	—	4	3
A	2	6	—	—
H	2	—	4	1
Y	—	—	5	3

Curve No.

Spool type	Limits of use - inlet flow port 3	
	Pressure in 2	Pressure in 4
D	A	A
C	A	A
A	B	C
H	—	A
Y	—	A

Curve No.

SPOOL SCHEME

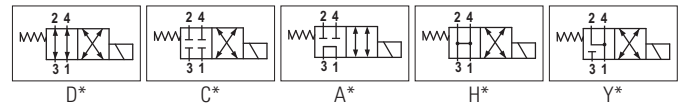

The tests were carried out with the solenoids 22W at operating temperature, with a supply voltage 10% below nominal value and with a 40°C fluid temperature. The fluid used is a mineral oil with viscosity of 46 mm²/s at 40°C.

ORDERING CODE

C4V 04 22 * 2 F * * ** 1

1 = Serial No.

C3V = Solenoid valve 4 way / 2 positions (Series)

04 = 3/4 - 16 UNF (Size)

22 = 22 W (C36) (Coil)

***** = See "Spool scheme" (Spool)

2 = Position number

F = Seat (Seat type)

00 = No variants

FK = Flying 600 mm (1)

AJ = AMP Junior connection (1)

CX = Deutsch connection with bidirectional diode

Connector to be ordered separately, see sect. 20

DC 22W (C36)

L = 12 VDC

M = 24 VDC

N = 48 VDC

2 = 21.6 VDC RAC (2)

Z = 102 VDC RAC (3)

X = 205 VDC RAC (4)

W = Without coil (5)

Coils technical data, see sect. 19

S = Without emergency

E = With emergency

(1) Only voltages 12 VDC - 24 VDC

(2) With rectifier: 24Vac/50-60Hz

(3) With rectifier: 115Vac/50Hz - 120Vac/60Hz

(4) With rectifier: 230Vac/50Hz - 240Vac/60Hz

(5) Performance are guaranteed only using valves completed with BFP coil

SOLENOID VALVES 4 WAY 3 POSITIONS

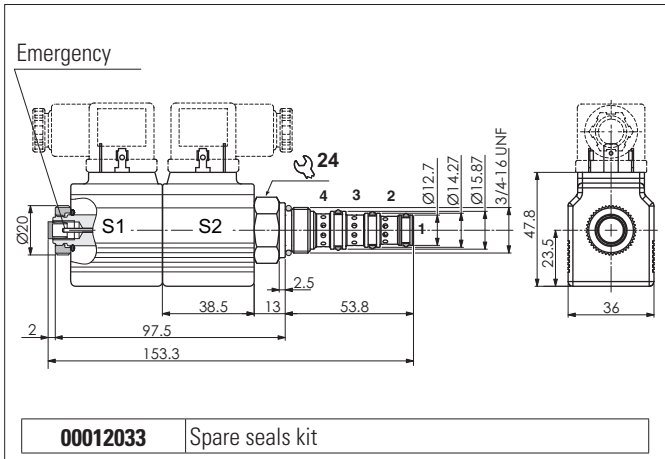

00012033 Spare seals kit

Connector to be ordered separately, see sect. 20

The electric valve is a 4-way 3-position directional electrically controlled valve.
Slight leakage is tolerated for this type of valve.
Available in 4 layouts.
The valves work with DC coils whereas RAC coils with a connector with incorporated rectifier must be used for AC applications.
The sleeve is in galvanised steel. The plunger is in tempered and ground steel.

HYDRAULIC FEATURES

Max. working pressure	250 bar
Max. Flow	18 l/min
Max. excitation frequency	2 Hz
Duty cycle	100% ED
Hydraulic fluid	DIN 51524 Mineral oils
Fluid viscosity	10 ÷ 500 mm ² /s
Fluid temperature	-25°C ÷ 75°C
Ambient temperature	-25°C ÷ 60°C
Max. contamin. level class with filter	ISO 4406:1999 - class 19/17/14
Type of protection (in relation to the connector used)	IP 65
Weight	0.34 kg
Cartridge tightening torque	25 ÷ 30 Nm
Emergency P1 tightening torque	7 Nm
Cavity (3/4 - 16 UNF)	CD018001 (See section 17)

PRESSURE DROPS

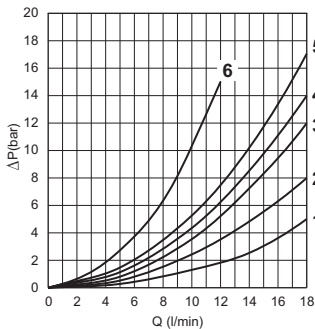

LIMIT OF USE

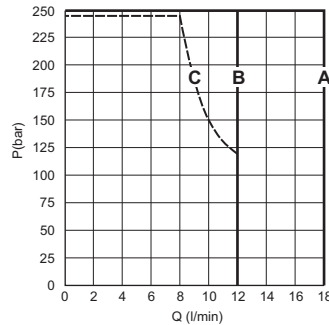

Spool type	Connections (pressure drops)				
	3→1	3→2	3→4	2→1	4→1
C	—	4	4	3	4
A	2	6	6	4	4
H	2	2	2	1	1
Y	—	5	5	3	4

Curve

Spool type	Connections (limits of use)				
	3→1	3→2	3→4	2→1	4→1
C	—	A	A	A	B
A	B	B	B	B	C
H	A	A	A	A	A
Y	—	A	A	A	A

Curve

SPOOL SCHEME

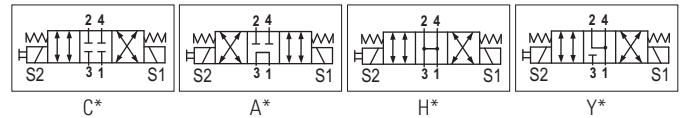

The tests were carried out with the solenoids 22W at operating temperature, with a supply voltage 10% below nominal value and with a 40°C fluid temperature.
The fluid used is a mineral oil with viscosity of 46 mm²/s at 40°C.

ORDERING CODE

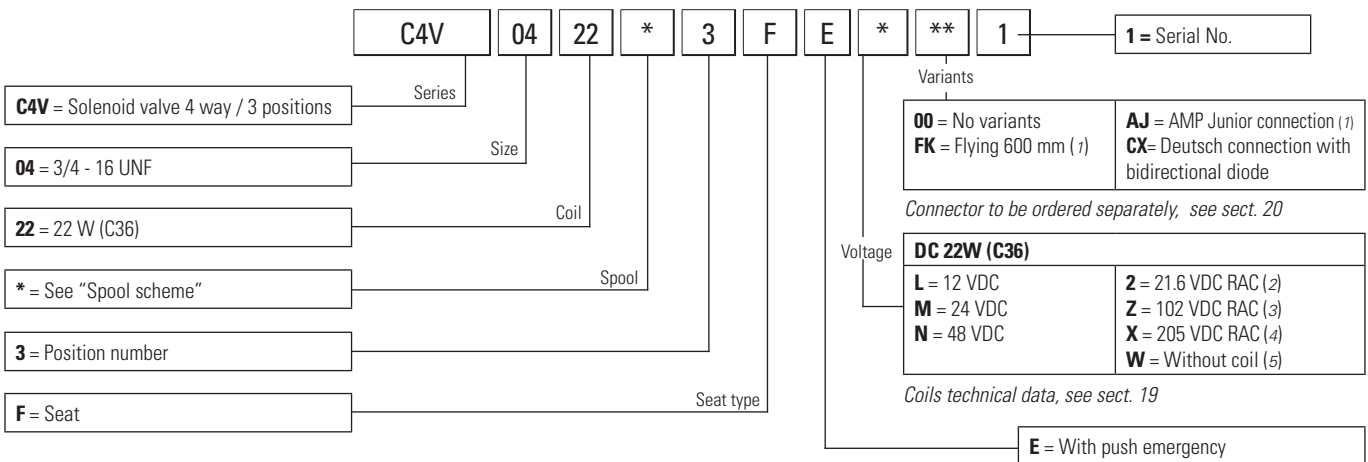

(1) Only voltages 12 VDC - 24 VDC

(2) With rectifier: 24VAC/50-60Hz

(3) With rectifier: 115VAC/50Hz - 120VAC/60Hz

(4) With rectifier: 230VAC/50Hz - 240VAC/60Hz

(5) Performance are guaranteed only using valves completed with BFP coil

DIVERTER VALVES

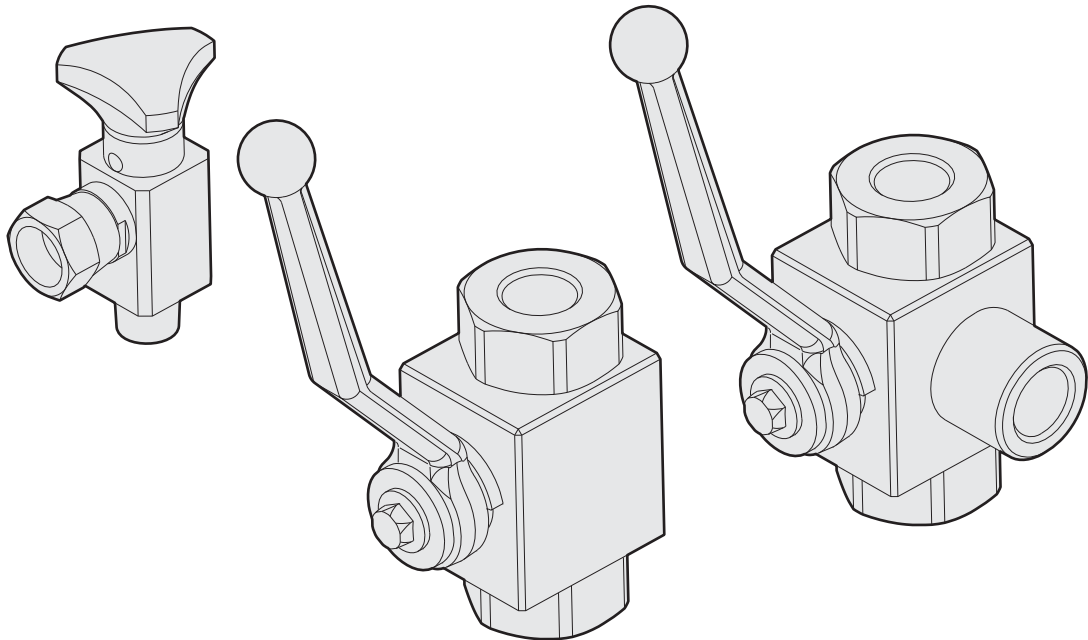

PRESSURE GAUGE SHUT-OFF - IN-LINE MOUNTING

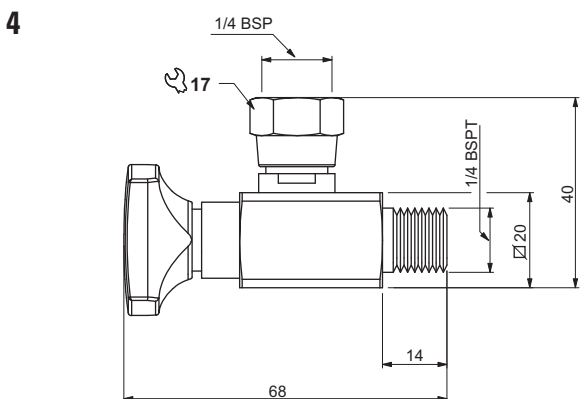
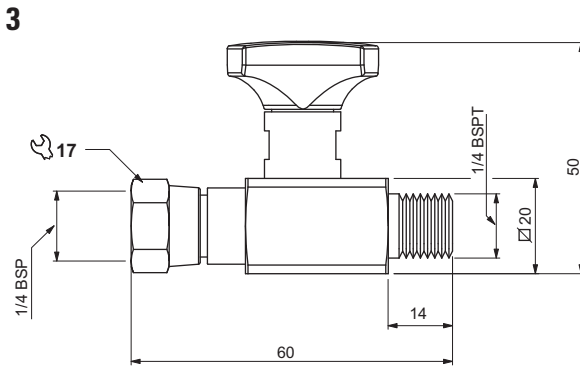
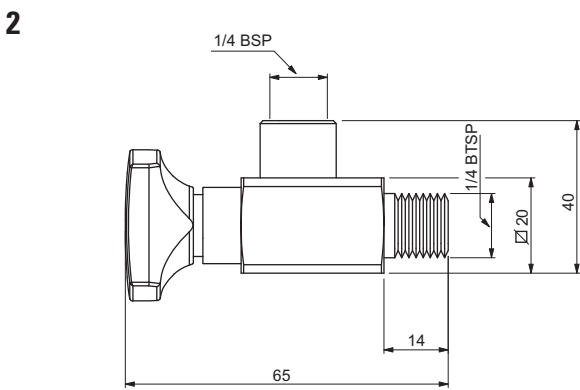
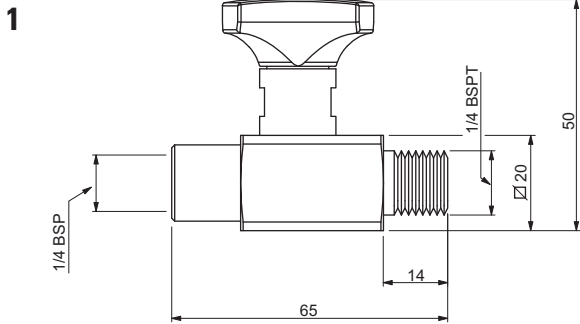

MR.7... in line - MRA.7... at 90°

This in-line mounting shut-off is completely steel made and allows for operating pressure of up to 400 bar. Its uses is essential to protect measuring gauge in the eventuality of fluid hammer.

MRG.7... in line with revolving nut MRAG.7... at 90° with revolving nut

This in-line mounting shut-off is completely steel made and allows for operating pressure of up to 400 bar. It has been designed to allow for independent mounting of the measuring gauge over a 360° angle, obviating in this way any problem relative to the gauge dimensions and mounting position. Its uses is essential to protect measuring gauge in the eventuality of fluid hammer.

HYDRAULIC SYMBOL

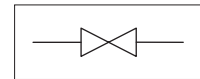

ORDERING CODE

Ref	Code	Description	Pressure max (bar)	Weight (kg)
1	MR7002	In line	400	0.115
2	MRA7002	At 90°	400	0.130
3	MRG7002	In line with revolving nut	400	0.120
4	MRAG7002	At 90° with revolving nut	400	0.135

HIGH PRESSURE - 2 WAY BALL VALVES - IN-LINE MOUNTING

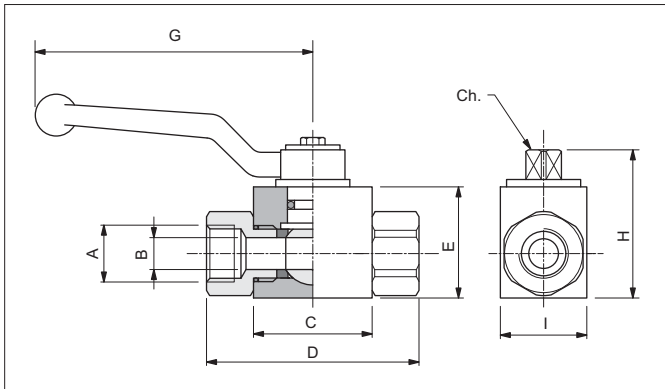

High pressure 2 way ball valves for in line mounting.
Steel body with external zinc plating. Cromed steel ball, aluminium lever.

HYDRAULIC SYMBOL

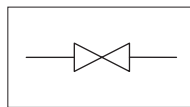

HYDRAULIC FEATURES

Hydraulic fluid	DIN 51524 Mineral oils
Fluid viscosity	10 ÷ 500 mm ² /s
Fluid temperature	-25°C ÷ 75°C
Ambient temperature	-25°C ÷ 60°C
Max. contamin. level class with filter	ISO 4406:1999 - class 19/17/14

Code	Thread A	Flow max (l/min)	Pressure max (bar)	B (mm)	C (mm)	D (mm)	E (mm)	G (mm)	H (mm)	I (mm)	Ch (mm)	Weight (kg)
RBS502	1/8 BSP	5	500	4	42	71	35	110	49	30	9	0.50
RBS504	1/4 BSP	10	500	6	42	71	35	110	49	30	9	0.50
RBS506	3/8 BSP	25	500	10	44	73	40	110	54	35	9	0.65
RBS508	1/2 BSP	40	500	13	48	83	43	110	57	37	9	0.75
RBS512	3/4 BSP	100	400	20	62	95	55	180	73	45	14	1.40
RBS516	1 BSP	150	350	25	66	113	65	180	83	55	14	2.15
RBS520	1-1/4 BSP	150	350	25	66	121	65	180	83	55	14	2.25
RBS524	1-1/2 BSP	150	350	25	66	124	65	180	83	55	14	2.35

ORDERING CODE

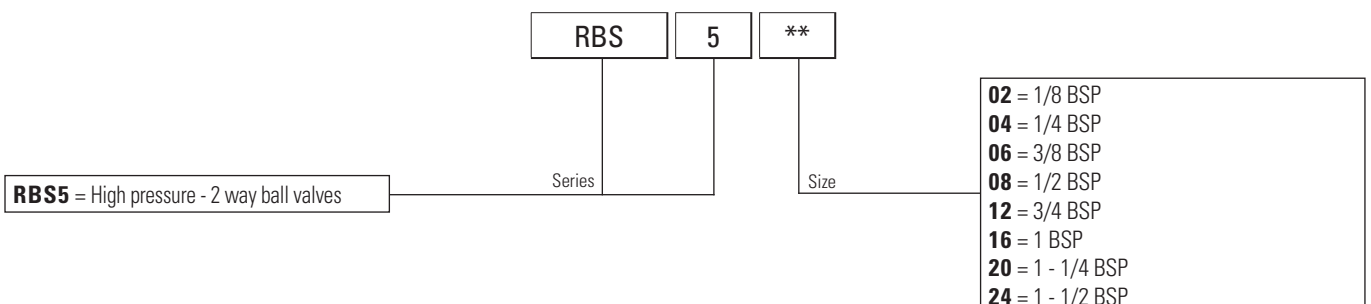

HIGH PRESSURE - 3 WAY BALL VALVES - IN-LINE MOUNTING

High pressure 3 way ball valves for in line mounting.
Steel body with external zinc plating. Cromed steel ball, aluminium lever.

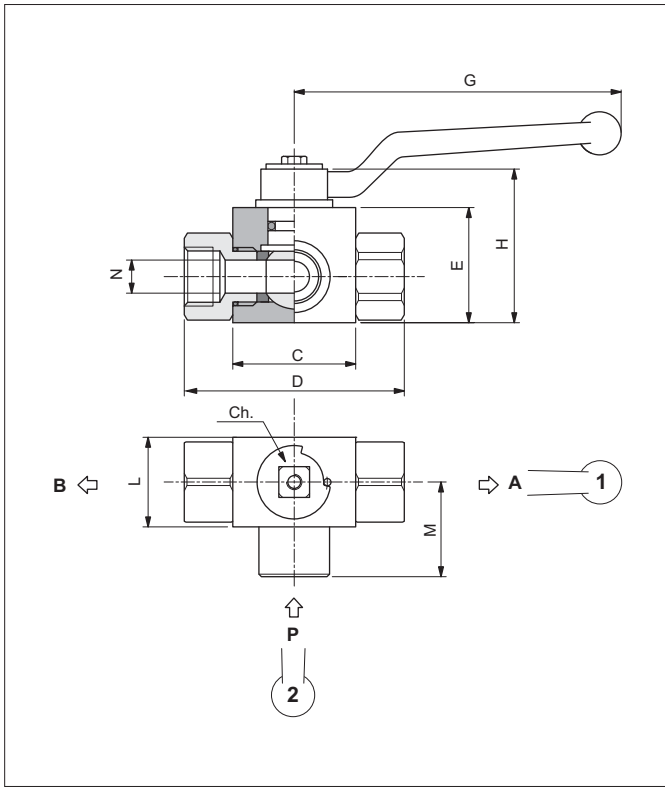

HYDRAULIC FEATURES

Hydraulic fluid	DIN 51524 Mineral oils
Fluid viscosity	10 ÷ 500 mm ² /s
Fluid temperature	-25°C ÷ 75°C
Ambient temperature	-25°C ÷ 60°C
Max. contamin. level class with filter	ISO 4406:1999 - class 19/17/14

HYDRAULIC SYMBOLS

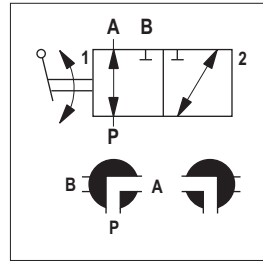

SCHEME "A"

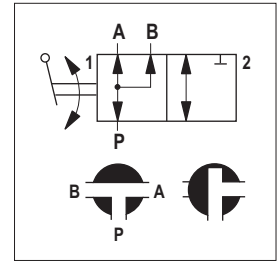

SCHEME "B"

Code	Thread A-B-P	Flow max (l/min)	Pressure max (bar)	C (mm)	D (mm)	E (mm)	G (mm)	H (mm)	L (mm)	M (mm)	N (mm)	Ch (mm)	Weight (kg)
BK3 A/B 02	1/8 BSP	5	400	42	71	35	110	49	30	33.5	4	9	0.50
BK3 A/B 04	1/4 BSP	10	400	42	71	35	110	49	30	33.5	6	9	0.50
BK3 A/B 06	3/8 BSP	25	400	44	73	40	110	54	35	37.0	10	9	0.70
BK3 A/B 08	1/2 BSP	70	350	48	83	43	110	57	37	40.0	13	9	0.80
BK3 A/B 12	3/4 BSP	100	350	62	95	55	180	73	45	52.0	20	14	1.50
BK3 A/B 16	1 BSP	150	350	66	113	65	180	83	55	60.0	25	14	2.35
BK3 A/B 20	1-1/4 BSP	150	350	66	121	65	180	83	55	61.5	25	14	2.50
BK3 A/B 24	1-1/2 BSP	150	350	66	124	65	180	83	55	61.5	25	14	2.70

ORDERING CODE

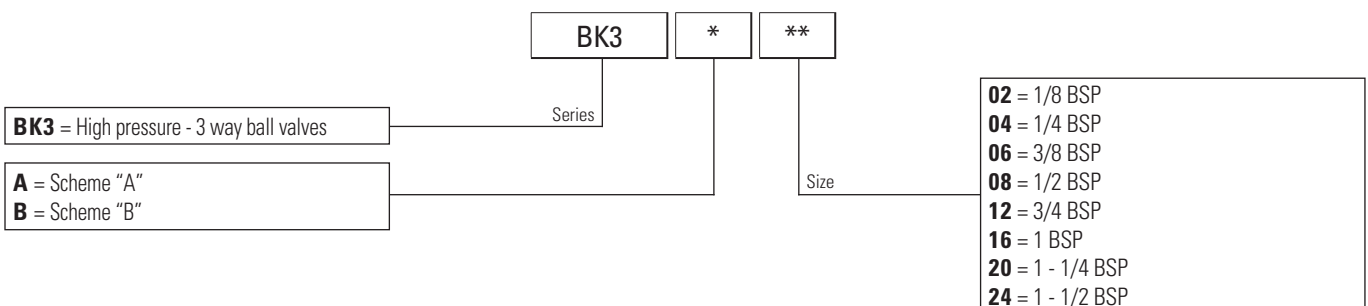

DIVERTER VALVES - IN-LINE MOUNTING

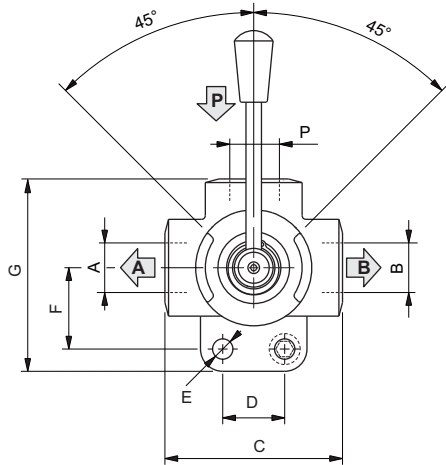

These valves allow the flow to be diverted to user points A or B by turning the control lever cursor to the left or right. They can be the 3- or 6-way type, with closed or open centre. Iron cast body black colour, white zinc plated external parts.

HYDRAULIC FEATURES

Hydraulic fluid	DIN 51524 Mineral oils
Fluid viscosity	10 ÷ 500 mm ² /s
Fluid temperature	-25°C ÷ 75°C
Ambient temperature	-25°C ÷ 60°C
Max. contamin. level class with filter	ISO 4406:1999 - class 19/17/14

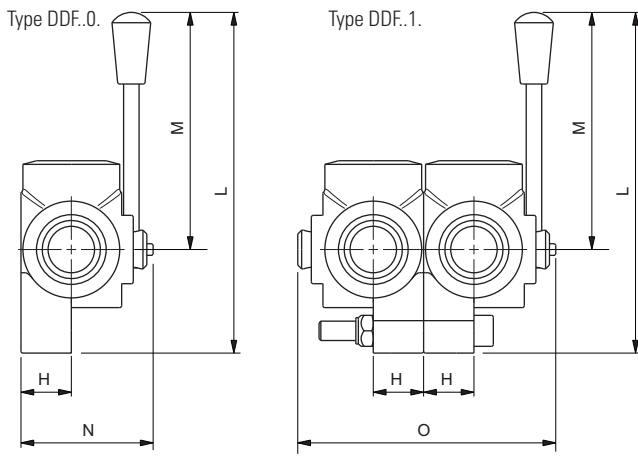

HYDRAULIC SCHEME

Scheme	Model	
	0 (3 Way)	1 (6 Way)
F open centre		
B closed centre		

Code	Thread P-A-B	Flow max (l/min)	Pressure max (bar)	C (mm)	D (mm)	E (mm)	F (mm)	G (mm)	H (mm)	L (mm)	M (mm)	N (mm)	O (mm)	Weight DDF.0.. (kg)	Weight DDF.1.. (kg)
DDF 04 ..	1/4 BSP	60	350	70	25	8.5	32	75.5	21	155.5	115	57	112	0.8	1.5
DDF 06 ..	3/8 BSP	60	350	70	25	8.5	32	75.5	21	155.5	115	57	112	0.8	1.5
DDF 08 ..	1/2 BSP	90	350	80	32	8.5	36	86	24	161	115	63	124	1.2	2.3
DDF 12 ..	3/4 BSP	120	350	90	32	10.5	42	98.5	26	168.5	115	67	132	1.8	3.5
DDF 16 ..	1 BSP	200	350	98	32	10.5	50	110	31	176.5	115	77	152	2.7	5.3

ORDERING CODE

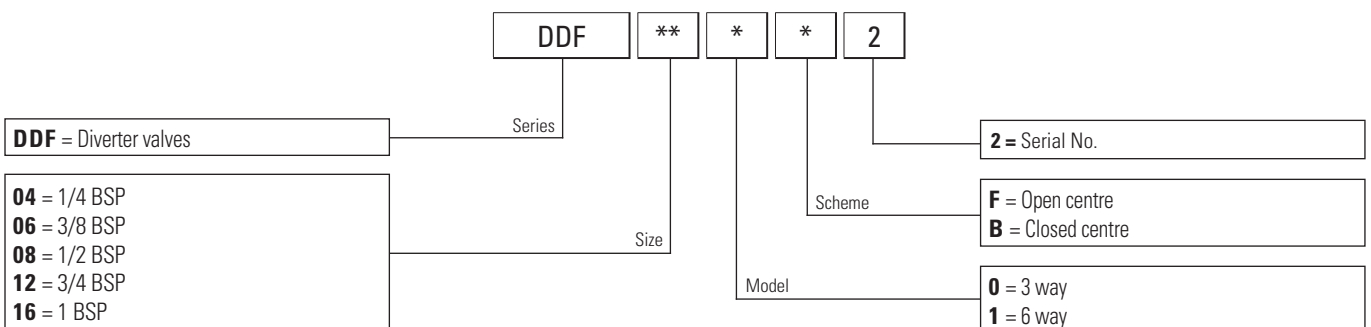

SOFT START VALVES

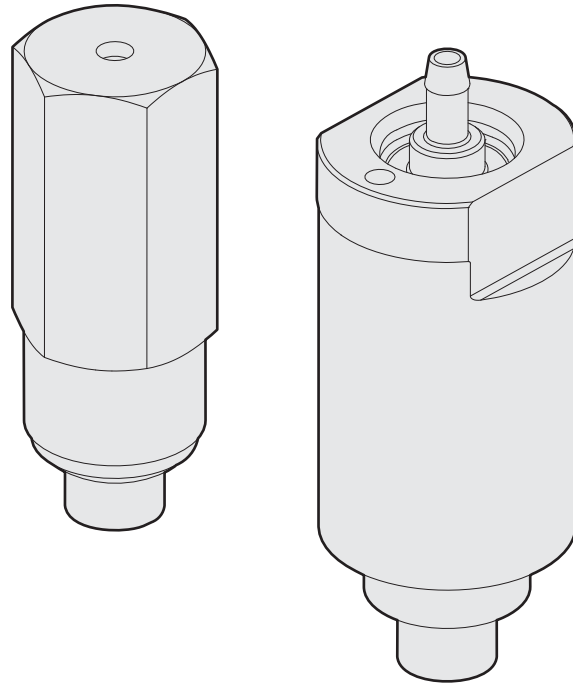

SINGLE-PHASE MOTOR START VALVE - IN-LINE MOUNTING

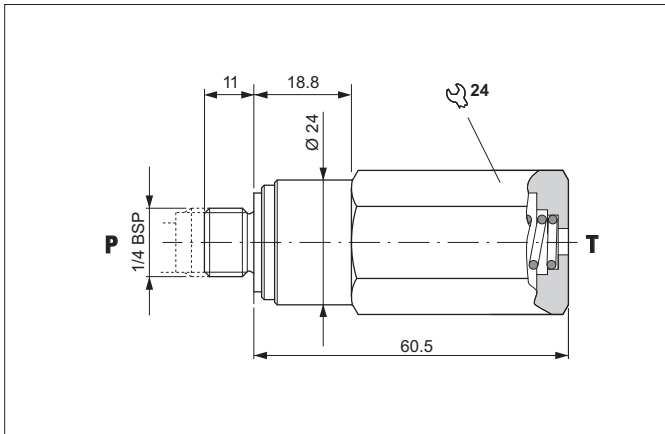

Valve used on power units to delay system pressurisation to allow a single-phase motor to reach the required speed.
 Fitted directly on the auxiliary pressure delivery line of unit 1 pumps or on the delivery branch between pump and unidirectional valve.
 The body is in steel and the tapered poppet in tempered and ground steel.

HYDRAULIC SYMBOL

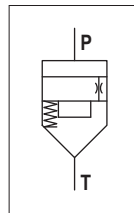

HYDRAULIC FEATURES

Max. working pressure	300 bar
Max. Flow	20 l/min
Min. working pressure	15 bar
Max operating frequency (with manual operated)	1 Hz
Working Temperature	-25°C ÷ 60°C
Hydraulic fluid	DIN 51524 Mineral oils
Fluid viscosity	10 ÷ 500 mm ² /s
Fluid temperature	-25°C ÷ 75°C
Max. contamin. level class with filter	ISO 4406:1999 - class 19/17/14
Weight	0.14 kg
Tightening torque	25 ÷ 30 Nm

11

ORDERING CODE

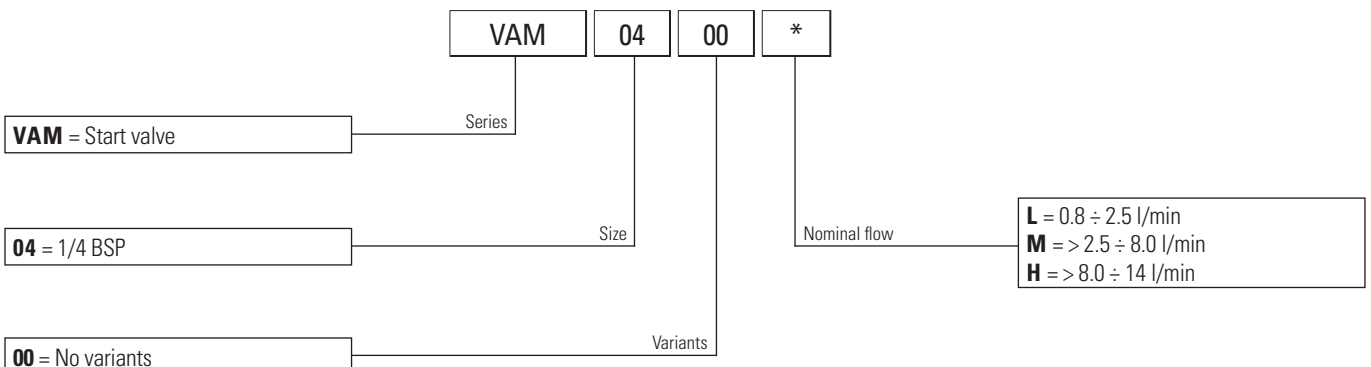

SOFT START VALVE - IN-LINE MOUNTING

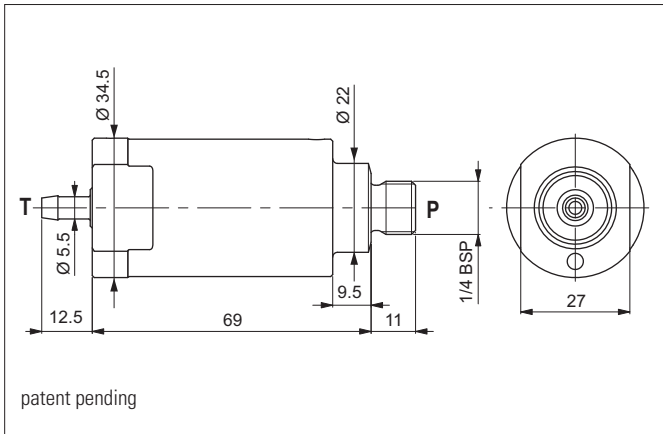

Valve used on power units to generate a flow rate ramp on the actuator to delay system pressurisation and allow the single phase motor to reach the required speed.

Fitted directly on the auxiliary pressure delivery line of unit 1 pumps or on the delivery branch between pump and unidirectional valve.

The body is in steel and the tapered poppet in tempered and ground steel.

HYDRAULIC SYMBOL

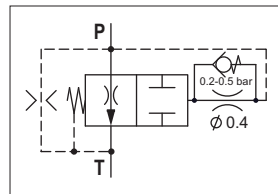

PRESSURE DROPS

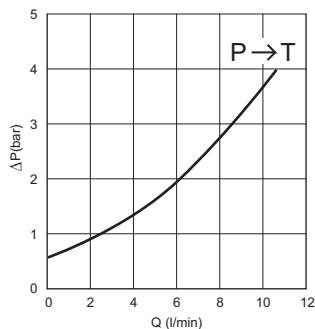

Fluid used: mineral based oil with viscosity 32 mm²/s at 40°C.

HYDRAULIC FEATURES

Max. working pressure	210 bar
Flow	8 ÷ 15 l/min
Rump up time (at 100 bar of working pressure)	600 ms
Max. Leakage at 100 bar	0.8 l/min
Operating frequency	0.7 Hz
Working Temperature	-25°C ÷ 60°C
Hydraulic fluid	DIN 51524 Mineral oils
Fluid viscosity	10 ÷ 500 mm ² /s
Fluid temperature	-25°C ÷ 75°C
Max. contamin. level class with filter	ISO 4406:1999 - class 19/17/14
Weight	0.4 kg
Tightening torque	25 ÷ 30 Nm

11

ORDERING CODE

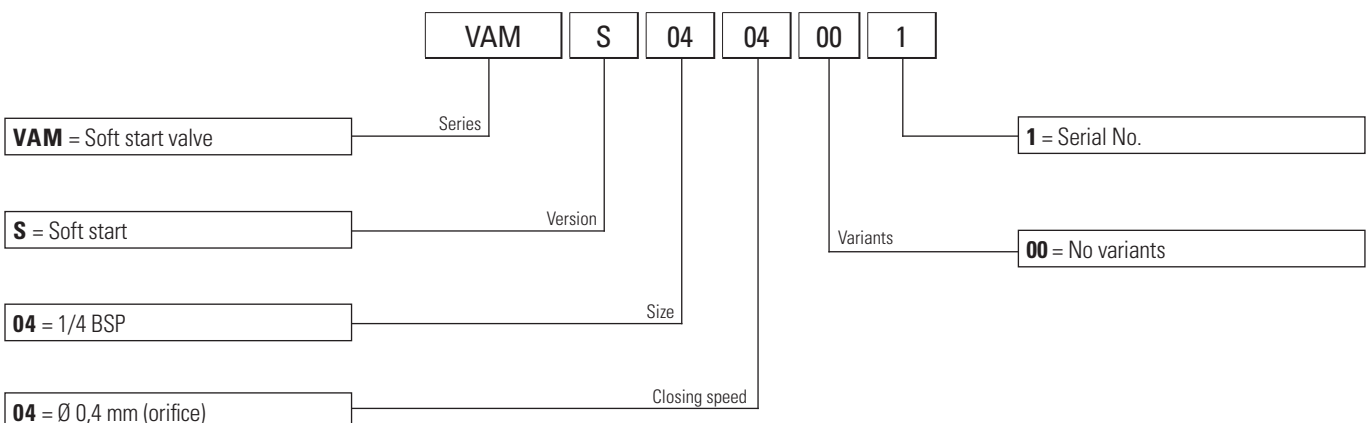

FLOW CONTROL VALVES

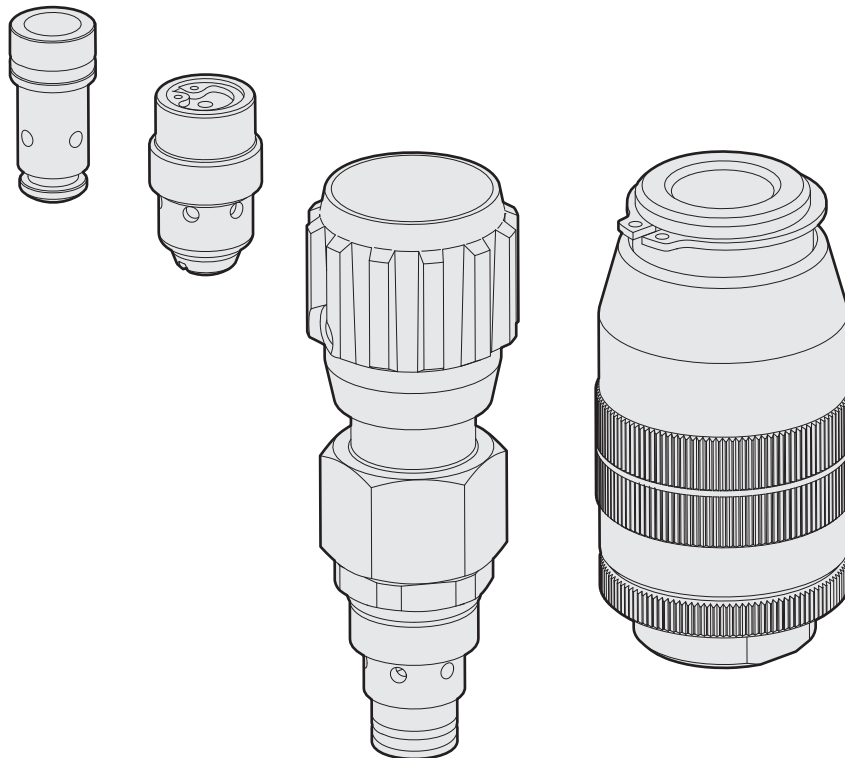

UNIDIRECTIONAL AND BIDIRECTIONAL FLOW CONTROL VALVES

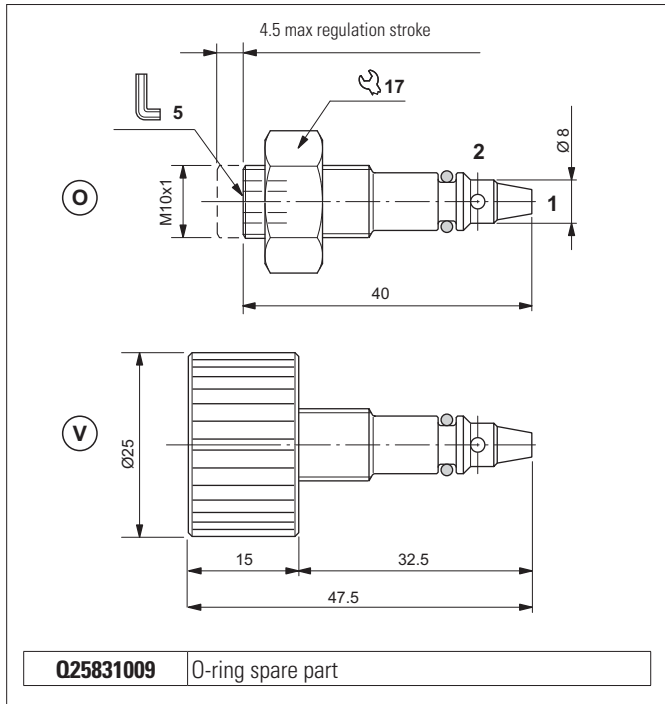

Flow control valve using non compensated throttling. The flow is reduced in one direction only, from 2 to 1, for SU valves and in both directions for SB valves. Guarantees excellent mechanical seal with negligible leakage. It has a galvanised steel body. The check valve guided ball poppet is in tempered and ground steel.

HYDRAULIC FEATURES

Max. working pressure	210 bar
Max. Flow	15 l/min
Hydraulic fluid	DIN 51524 Mineral oils
Fluid viscosity	10 ÷ 500 mm ² /s
Fluid temperature	-25°C ÷ 75°C
Ambient temperature	-25°C ÷ 60°C
Max. contamin. level class with filter	ISO 4406:1999 - class 19/17/14
Weight	0.022 kg
Nut tightening torque	15 Nm
Cavity (M10x1)	CN019002 (See section 17)

HYDRAULIC SYMBOLS

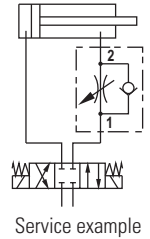
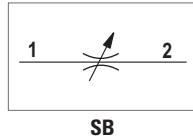
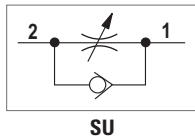

12

PRESSURE DROPS

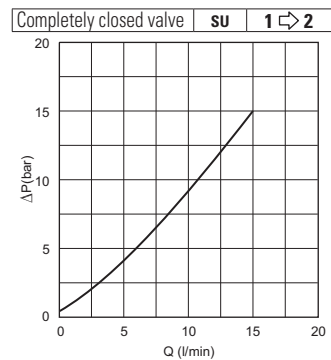
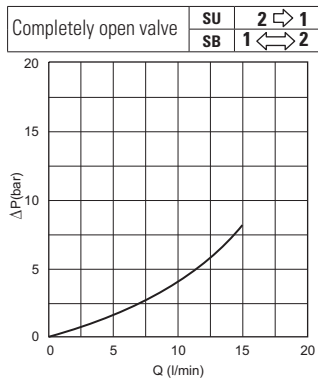

Fluid used: mineral based oil with viscosity 32 mm²/s at 40°C.

ORDERING CODE

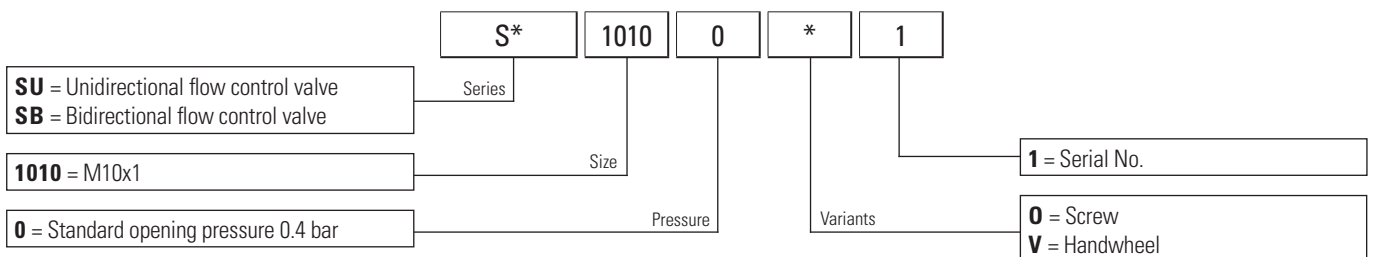

FIXED UNIDIRECTIONAL FLOW CONTROL VALVE

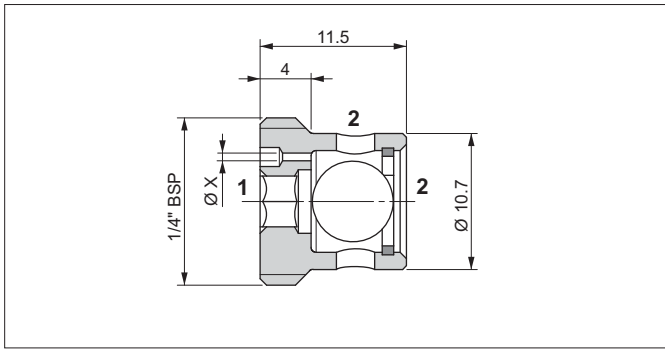

The valves control the flow in a single direction (2 to 1, the flow in opposite direction in free).
The flow is reduced by the control hole X which determines the flow rate (not compensated). Valves made steel.

HYDRAULIC FEATURES

Max. working pressure	210 bar
Max. Flow	20 l/min
Hydraulic fluid	DIN 51524 Mineral oils
Fluid viscosity	10 ÷ 500 mm ² /s
Fluid temperature	-25°C ÷ 75°C
Ambient temperature	-25°C ÷ 60°C
Max. contamin. level class with filter	ISO 4406:1999 - class 19/17/14
Weight	0.022 kg
Tightening torque	16 ÷ 18 Nm

HYDRAULIC SYMBOL

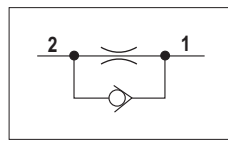

PRESSURE DROPS

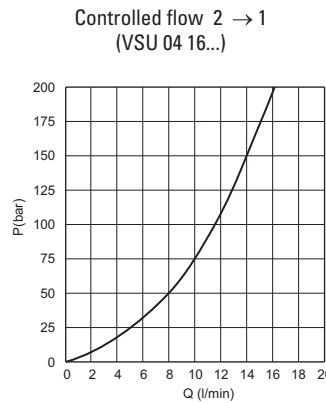
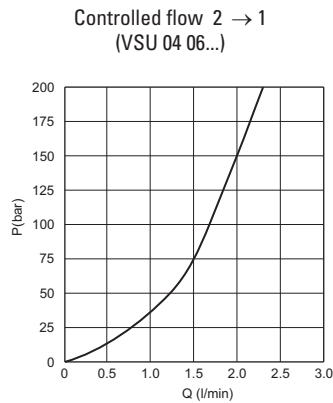
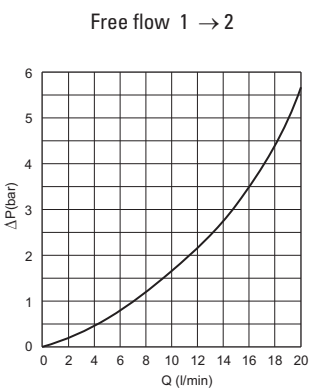

Fluid used: mineral based oil with viscosity 46 mm²/s at 40°C.

SEAL

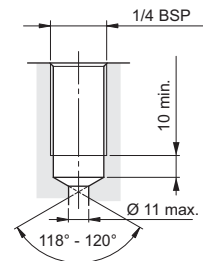

SERVICE EXAMPLE

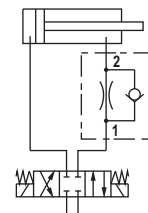

ORDERING CODE

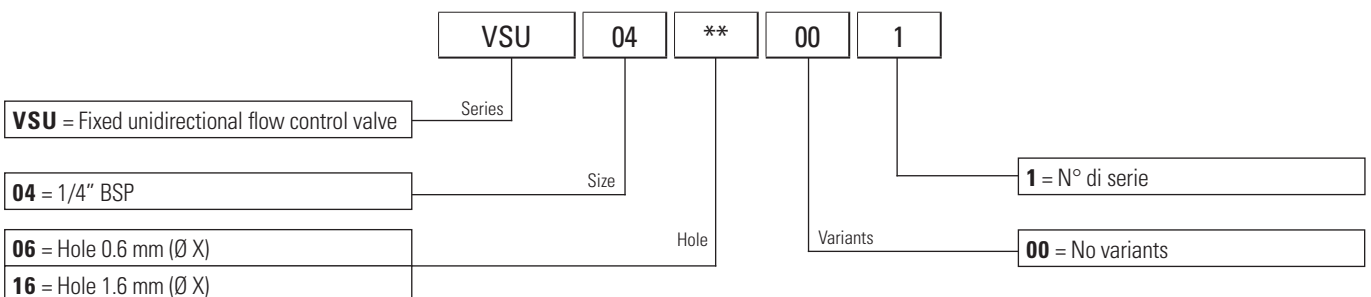

BIDIRECTIONAL FLOW CONTROL VALVE

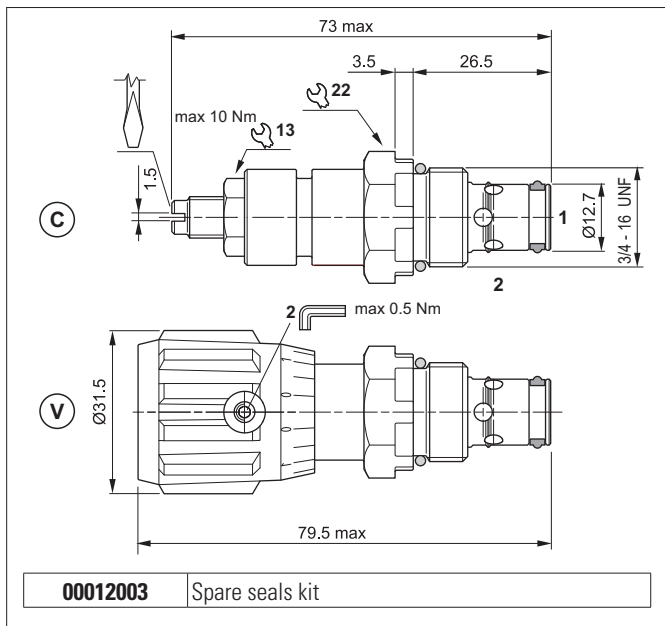

Flow control valve using non compensated throttling. The flow is reduced in both directions, turning the screw or wheel right or left. Guarantees excellent mechanical seal with negligible leakage. It has a galvanised steel body.

HYDRAULIC FEATURES

Max. working pressure	315 bar
Max. Flow	40 l/min
Hydraulic fluid	DIN 51524 Mineral oils
Fluid viscosity	10 ÷ 500 mm ² /s
Fluid temperature	-25°C ÷ 75°C
Ambient temperature	-25°C ÷ 60°C
Max. contamin. level class with filter	ISO 4406:1999 - class 19/17/14
Weight	0.11 kg
Tightening torque	25 ÷ 30 Nm
Cavity (3/4 - 16 UNF)	CD018006 (See section 17)

HYDRAULIC SYMBOL

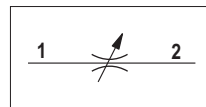

PRESSURE DROPS

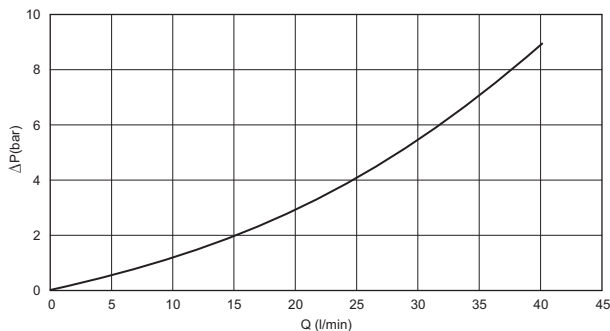

Fluid used: mineral based oil with viscosity 15 mm²/s at 40°C.

ORDERING CODE

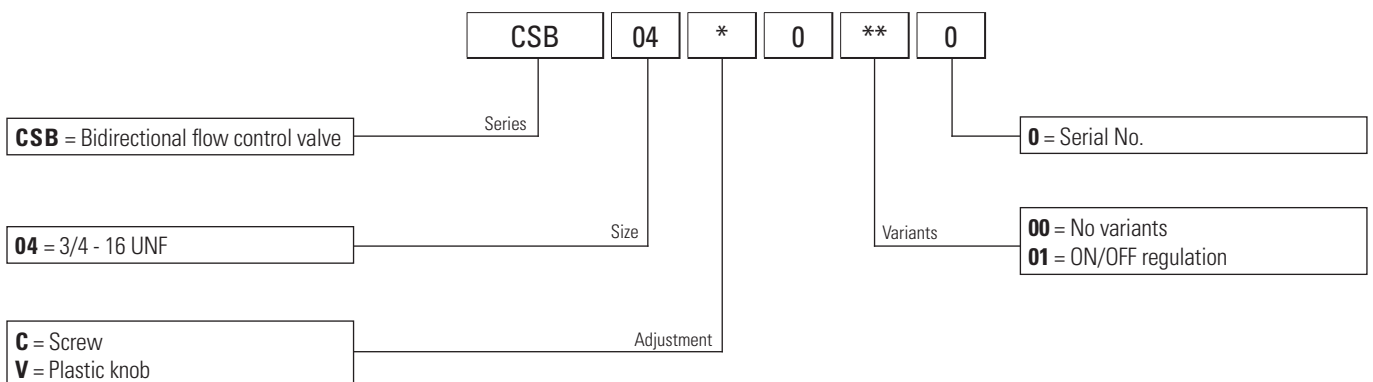

UNIDIRECTIONAL COMPENSATED FLOW CONTROL VALVES

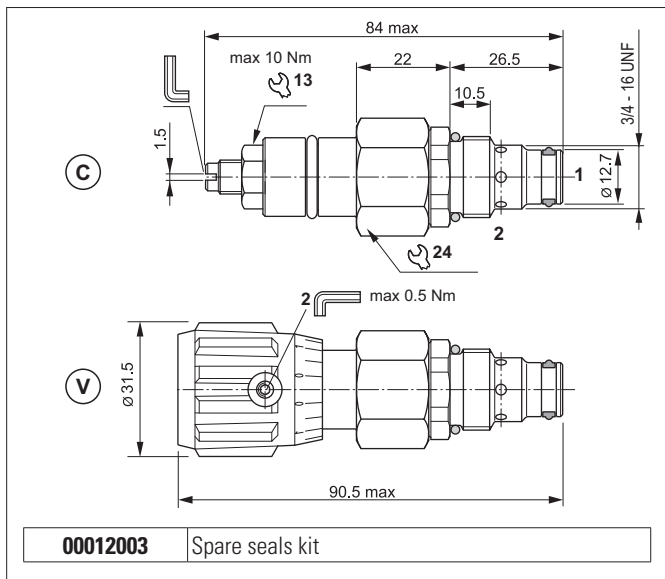

The flow control valve maintains a steady flow in a single direction (1 to 2) regardless of oil pressure. The flow is reduced by turning the screw or wheel right or left. Slight leakage is tolerated when the control screw or wheel is screwed down completely. It has a galvanised steel body. The compensator plunger is in tempered and ground steel.

HYDRAULIC FEATURES

Max. working pressure	250 bar
ΔP of regulation	12.6 bar
Max. Flow	29 l/min
Hydraulic fluid	DIN 51524 Mineral oils
Fluid viscosity	10 ÷ 500 mm ² /s
Fluid temperature	-25°C ÷ 75°C
Ambient temperature	-25°C ÷ 60°C
Max. contamin. level class with filter	ISO 4406:1999 - class 19/17/14
Weight	0.2 kg
Tightening torque	25 ÷ 30 Nm
Cavity (3/4 - 16 UNF)	CD018006 (See section 17)

HYDRAULIC SYMBOL

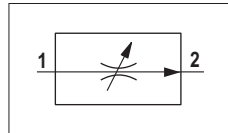

PRESSURE DROPS

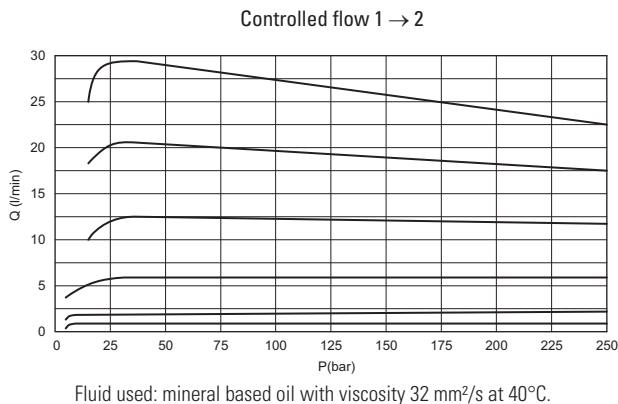

ORDERING CODE

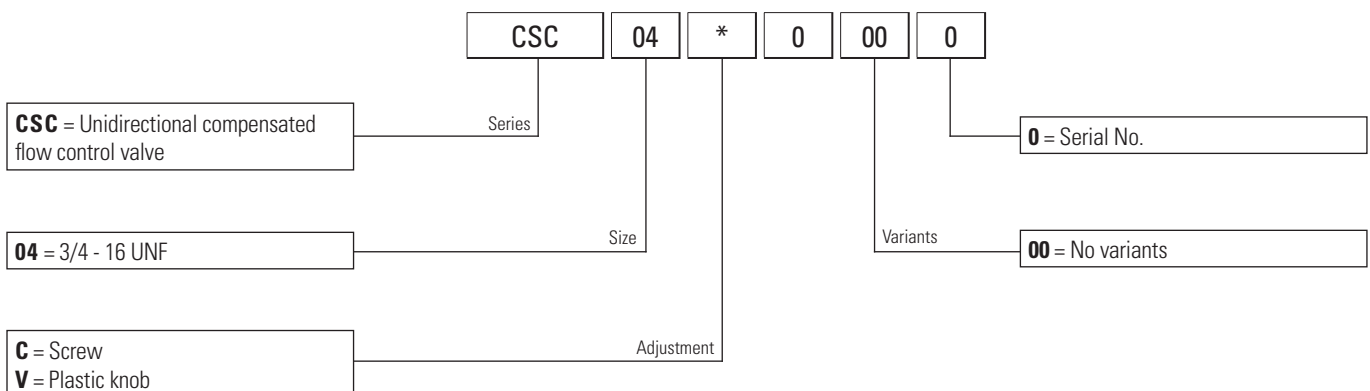

FIXED COMPENSATED FLOW CONTROL VALVE

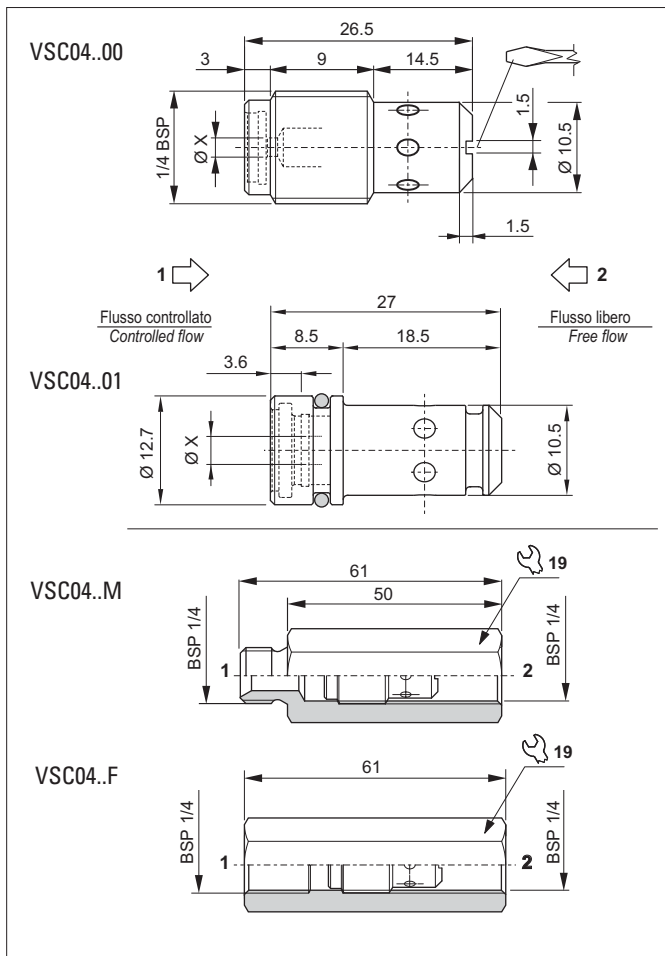

The flow control valve maintains a steady flow in a single direction (1 to 2) regardless of oil pressure.
 The flow is reduced by the control hole X which determines the flow rate.
 Steel body. Compensator plunger in ground steel.

HYDRAULIC FEATURES

Max. working pressure	250 bar
ΔP of regulation	5.4 ÷ 6.3 bar (2.3 bar variant 04)
Max. Flow	11.7 l/min
Hydraulic fluid	DIN 51524 Mineral oils
Fluid viscosity	10 ÷ 500 mm ² /s
Fluid temperature	-25°C ÷ 75°C
Ambient temperature	-25°C ÷ 60°C
Max. contamin. level class with filter	ISO 4406:1999 - class 19/17/14
Weight	0.014 kg
Tightening torque	6 ÷ 8 Nm
Cavity (for VSC04..01)	CD018009 (See section 17)

HYDRAULIC SYMBOL

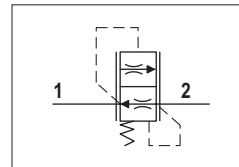

SEAL (FOR VSC04..00)

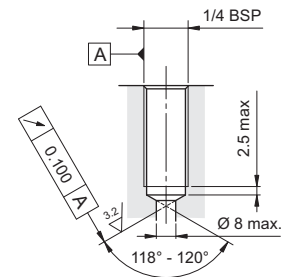

12

PRESSURE DROPS

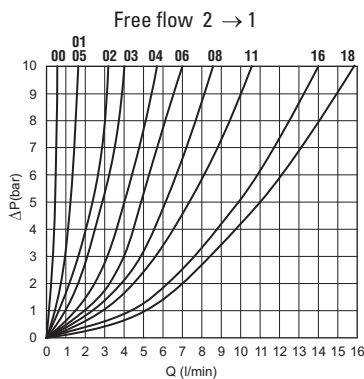

Fluid used: mineral based oil with viscosity 46 mm²/s at 40°C.

FLOW CONTROLLED BY "X" PORT

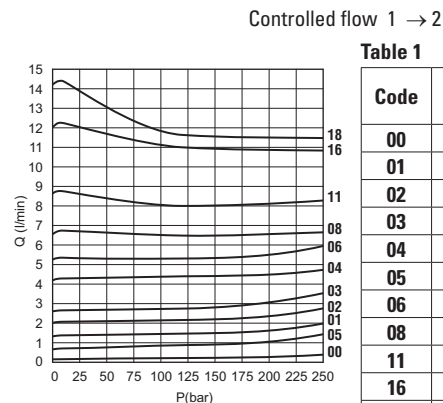
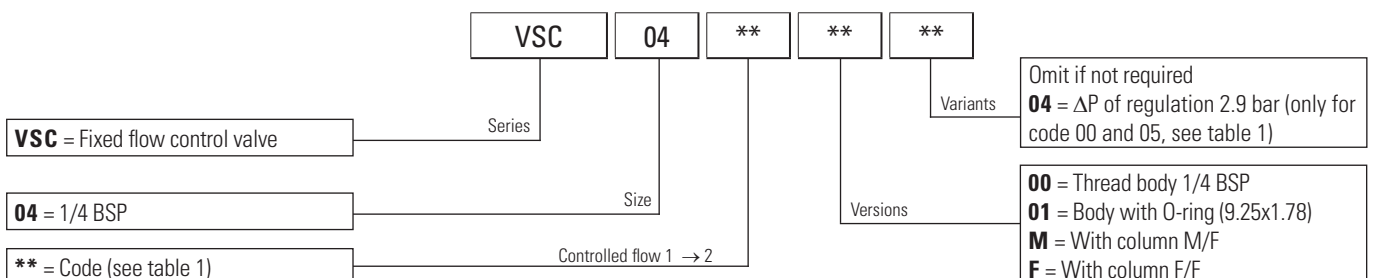

Table 1

Code	Ø X (mm)	Nominal flow at 120 bar (l/min)
00	0.50	0.3 (variant 04)
01	1.00	1.4
02	1.25	2.3
03	1.50	2.8
04	1.75	4.3
05	1.00	1.0 (variant 04)
06	2.00	5.2
08	2.25	6.5
11	2.50	8.0
16	3.00	11.1
18	3.20	11.7

ORDERING CODE



FIXED COMPENSATED FLOW CONTROL VALVE

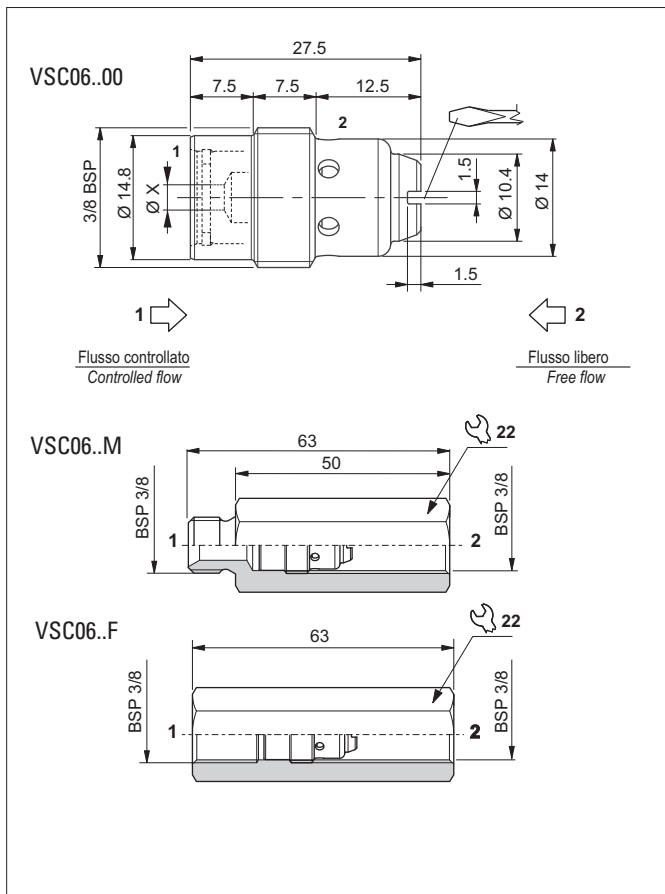

The flow control valve maintains a steady flow in a single direction (1 to 2) regardless of oil pressure. The flow is reduced by the control hole X which determines the flow rate. Steel body. Compensator plunger in ground steel.

HYDRAULIC FEATURES

Max. working pressure	250 bar
ΔP of regulation	6.0 ÷ 6.8 bar 2,2 bar (code 10-12 tab. 1)
Max. Flow	18.5 l/min
Hydraulic fluid	DIN 51524 Mineral oils
Fluid viscosity	10 ÷ 500 mm ² /s
Fluid temperature	-25°C ÷ 75°C
Ambient temperature	-25°C ÷ 60°C
Max. contamin. level class with filter	ISO 4406:1999 - class 19/17/14
Weight	0.026 kg
Tightening torque	6 ÷ 8 Nm

HYDRAULIC SYMBOL

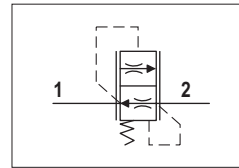

SEAL (FOR VSC06..00)

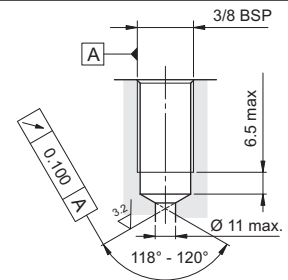

PRESSURE DROPS

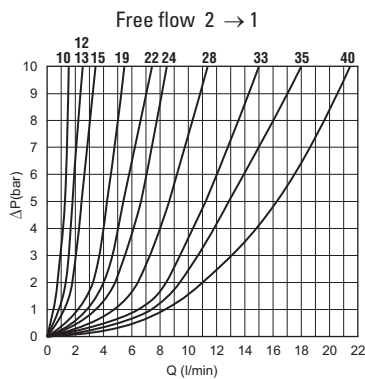

Fluid used: mineral based oil with viscosity 46 mm²/s at 40°C.

FLOW CONTROLLED BY "X" PORT

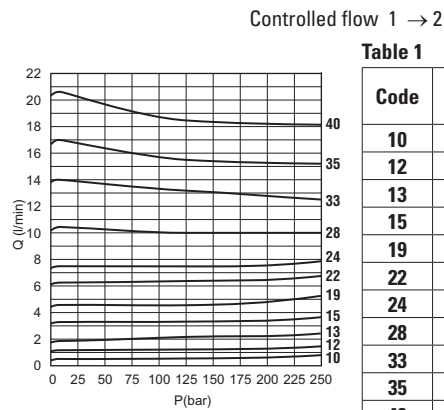
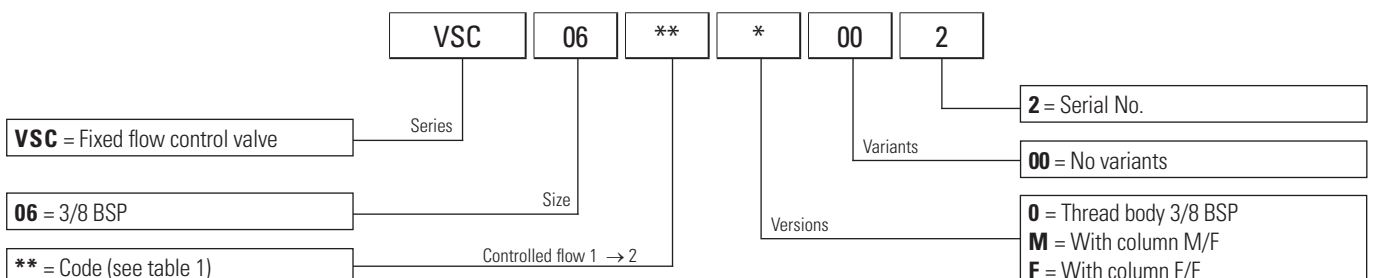

Table 1

Code	Ø X (mm)	Nominal flow at 120 bar (l/min)
10	1.00	0.7
12	1.25	1.1
13	1.25	2.1
15	1.50	3.2
19	1.90	4.7
22	2.20	6.3
24	2.40	7.5
28	2.75	10.0
33	3.25	13.2
35	3.50	15.7
40	4.00	18.5

ORDERING CODE



PRIORITY FLOW CONTROL VALVE

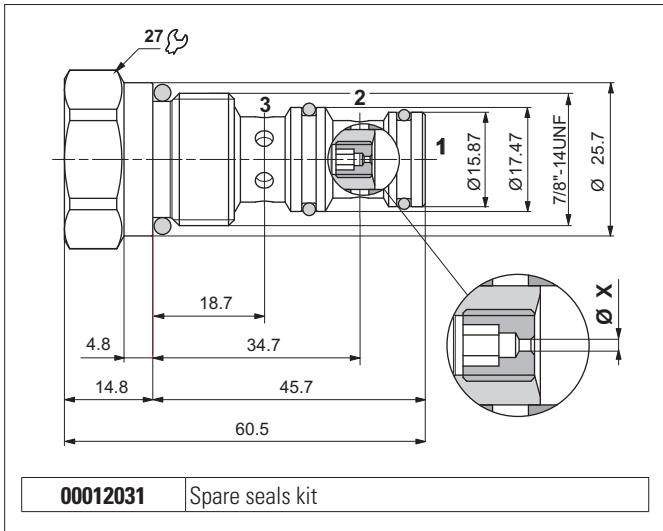

The priority flow control valve sends a constant flow from branch 1, first to priority branch 3 and then the remaining flow to overflow branch 2, regardless of the downstream oil pressure.

Both branches 2 and 3 can be pressurised.

The flow is reduced by the control hole X which determines the flow rate.

It has a galvanised steel body. The compensator plunger is in tempered and ground steel.

HYDRAULIC FEATURES

Max. working pressure	210 bar
ΔP of regulation	6.1 ÷ 6.7 bar
Input max. Flow	50 l/min
Control max. Flow	17 l/min
Hydraulic fluid	DIN 51524 Mineral oils
Fluid viscosity	10 ÷ 500 mm ² /s
Fluid temperature	-25°C ÷ 75°C
Ambient temperature	-25°C ÷ 60°C
Max. contamin. level class with filter	ISO 4406:1999 - class 19/17/14
Weight	0.2 kg
Tightening torque	30 ÷ 40 Nm
Cavity (7/8 - 14 UNF)	CD019006 (See section 17)

HYDRAULIC SYMBOL

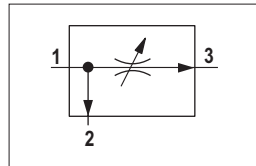

FLOW CONTROLLED

12

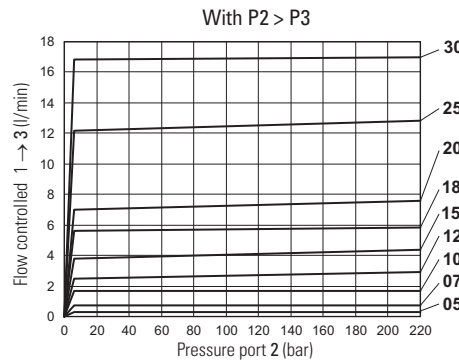
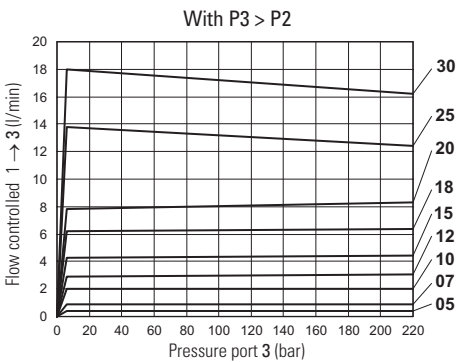

Fluid used: mineral based oil with viscosity 46 mm²/s at 40°C.
The regulated flow rate depends on the inlet flow rate and the oil viscosity.

Table 1

Code	Ø X (mm) **	Nominal flow (l/min) *
05	0.5	0.3
07	0.7	0.7
10	1.0	1.7
12	1.2	2.5
15	1.5	4.0
18	1.8	5.6
20	2.0	7.0
25	2.5	12.2
30	3.0	17.0

* Flow rate tolerance: ±15% up to 5 l/min, ±10% over 5 l/min

** Tolerance on hole: ±0.02 mm

ORDERING CODE

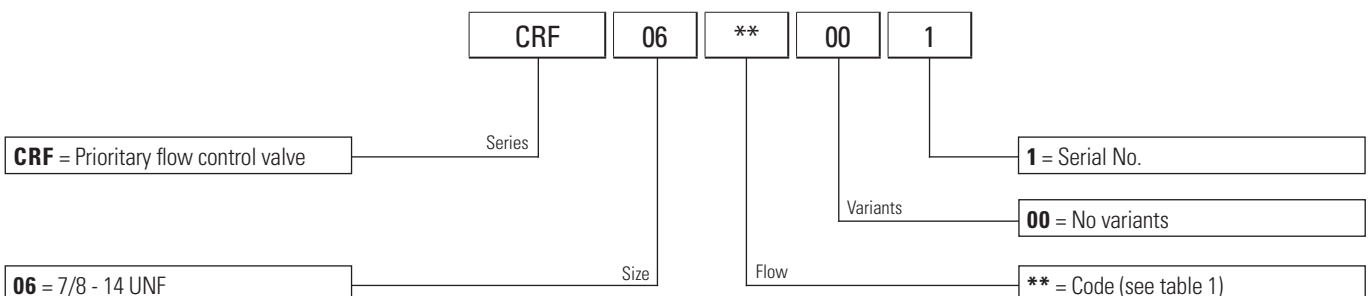

PRESSURE COMPENSATOR VALVE

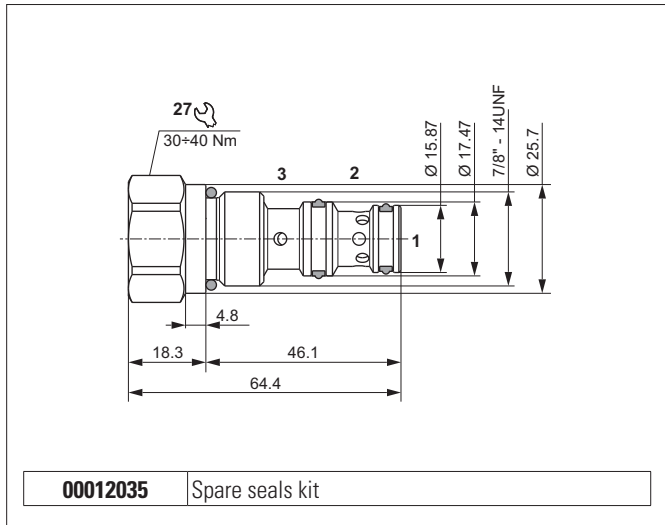

Pressure compensator valves allow to control flow and pressure. The valve is normally closed and with external pilot additive to the spring bias pressure. When the pressure at port 1 rises above the spring bias pressure with the addition of external pilot pressure, then the valve shifts to allow flow from port 1 to port 2 connected to tank. The valve is used as a bypass for a fixed displacement pump in Load Sensing circuits or to proportionally control the speed of an actuator (see examples).

The valve body is made of steel zinc coated and the pressure compensating spool is made of steel tempered and grinded.

HYDRAULIC FEATURES

Max. working pressure	250 bar
ΔP of regulation	8 - 13 bar
Input max. Flow	50 l/min
Hydraulic fluid	DIN 51524 Mineral oils
Fluid viscosity	10 ÷ 500 mm ² /s
Fluid temperature	-25°C ÷ 75°C
Ambient temperature	-25°C ÷ 60°C
Max. contamin. level class with filter	ISO 4406:1999 - class 19/17/14
Weight	0.2 kg
Tightening torque	30 ÷ 40 Nm
Cavity (7/8" - 14 UNF)	CD019006 (See section 17)

HYDRAULIC SYMBOL

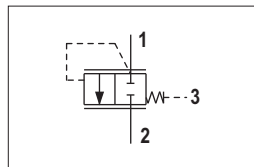

PRESSURE DROPS (1 → 2)

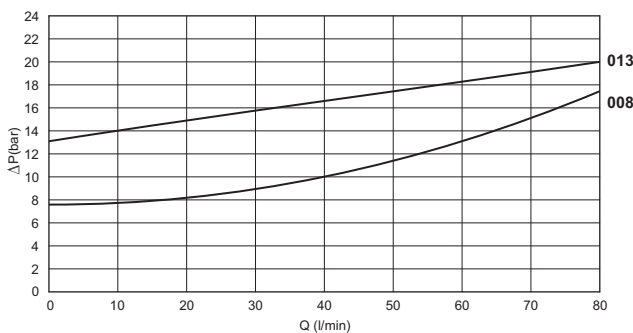

Fluid used: mineral based oil with viscosity 46 mm²/s at 40°C.

SERVICE EXAMPLE

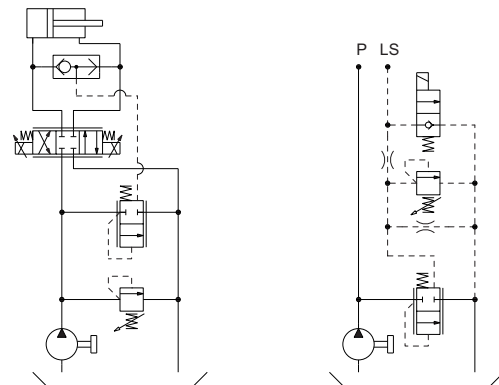

ORDERING CODE

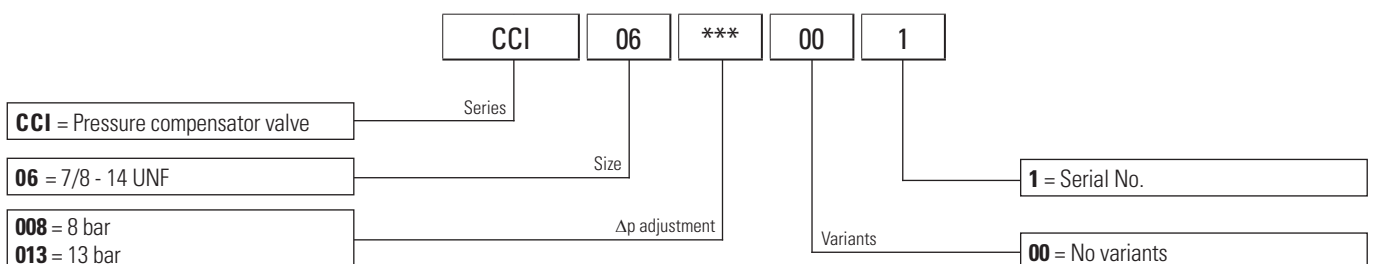

TWO-WAY PRESSURE COMPENSATOR VALVE

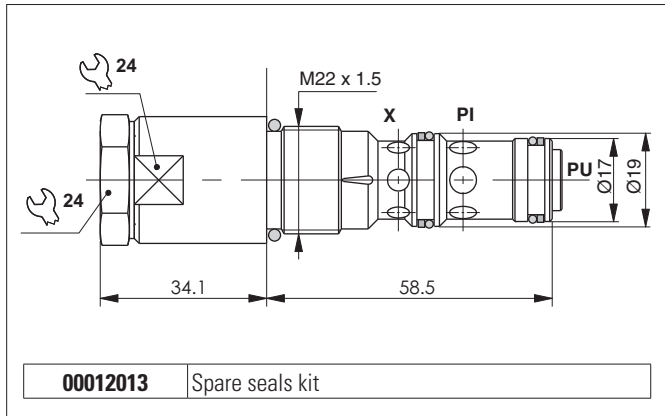

00012013 Spare seals kit

Pressure compensator type CCP maintains a constant pressure drop (Δp) regardless of downstream and up stream set pressure variation.

- Connecting a choke regulator between Pu port and Pil - piloting port - (see hydraulic scheme) it is possible to get a load independent flow regulation.
- This kind of compensator, named "meter in" (check in entrance), is suitable for application on special manifold or in line mounting bodies.

HYDRAULIC SYMBOLS

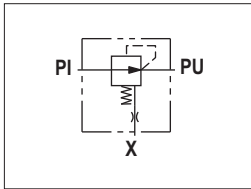

SIMPLIFIED SCHEME

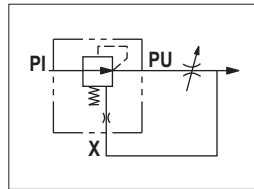

APPLICATION SCHEME

HYDRAULIC FEATURES

Max. working pressure	250 bar
ΔP of regulation (standard)	8 bar
Max. Flow	50 l/min
Hydraulic fluid	DIN 51524 Mineral oils
Fluid viscosity	10 ÷ 500 mm ² /s
Fluid temperature	-25°C ÷ 75°C
Ambient temperature	-25°C ÷ 60°C
Max. contamin. level class with filter	ISO 4406:1999 - class 19/17/14
Weight	0.2 kg
Tightening torque	30 ÷ 40 Nm
Cavity (M22x1.5)	CN047002 (See section 17)

12

ΔP BETWEEN PU AND X - FLOW

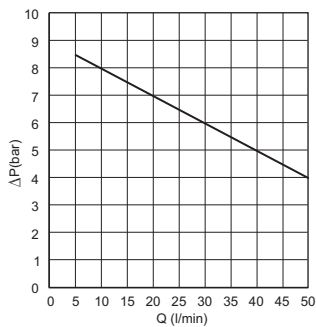

Fluid used: mineral based oil with viscosity 46 mm²/s at 40°C.

PRESSURE - FLOW RATE

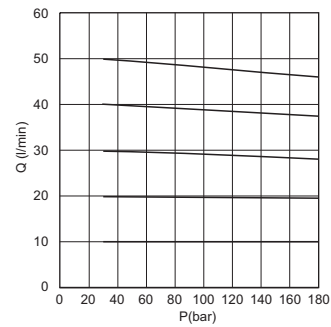

ORDERING CODE

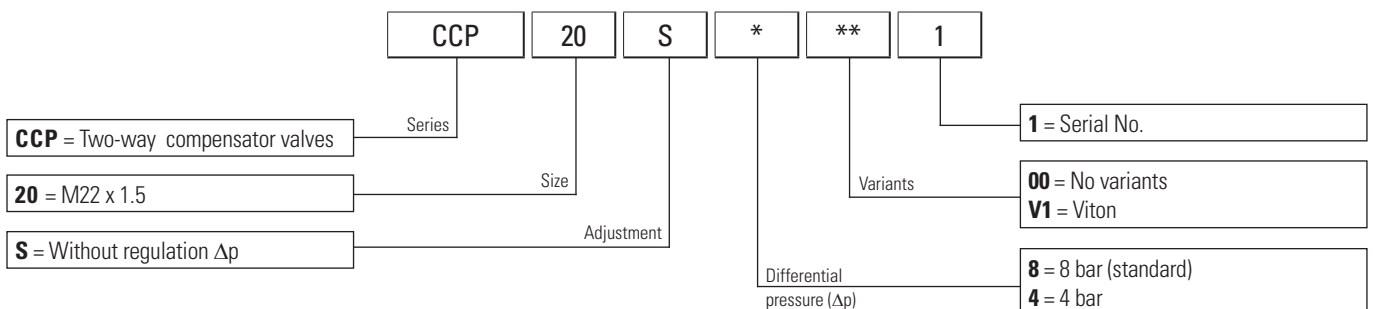

SLEEVE FLOW CONTROL VALVES UNIDIRECTIONAL AND BIDIRECTIONAL - IN-LINE MOUNTING

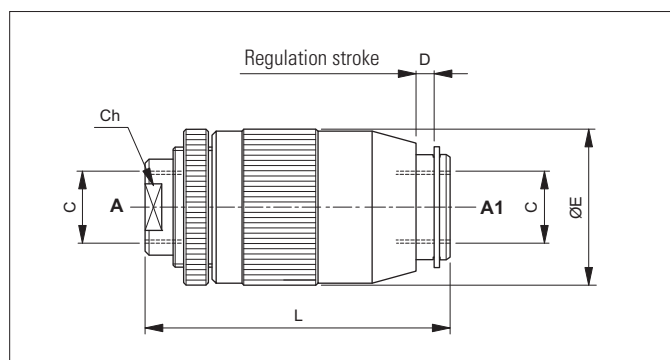

Flow control valve using non compensated throttling. The flow is reduced in only one direction (A to A1) for VSR valves and in both directions for VSB valves, by turning the outer casing of the valve right or left. Slight leakage is tolerated when the control screw or wheel is completely unscrewed. It has a galvanised steel body. The check valve ball poppet is in tempered and ground steel.

Code	C	Flow max (l/min)	Pressure max (bar)	L (mm)	E (mm)	D (mm)	Ch	Weight (kg)
VSR-VSB 0400	1/4 BSP	15	350	62	31	4.2	19	0.23
VSR-VSB 0600	3/8 BSP	30	350	73	38	4	24	0.42
VSR-VSB 0800	1/2 BSP	45	350	83	45	7.5	30	0.66
VSR-VSB 1200	3/4 BSP	85	300	102	54	10.5	36	1.12
VSR-VSB 1600	1 BSP	130	250	122	65	10	41	1.94

HYDRAULIC FEATURES

Hydraulic fluid	DIN 51524 Mineral oils
Fluid viscosity	10 ÷ 500 mm ² /s
Fluid temperature	-25°C ÷ 75°C
Ambient temperature	-25°C ÷ 60°C
Max. contamin. level class with filter	ISO 4406:1999 - class 19/17/14

HYDRAULIC SYMBOLS

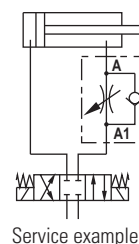
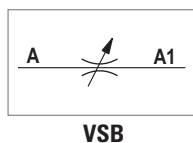
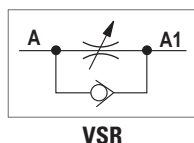

12

PRESSURE DROPS

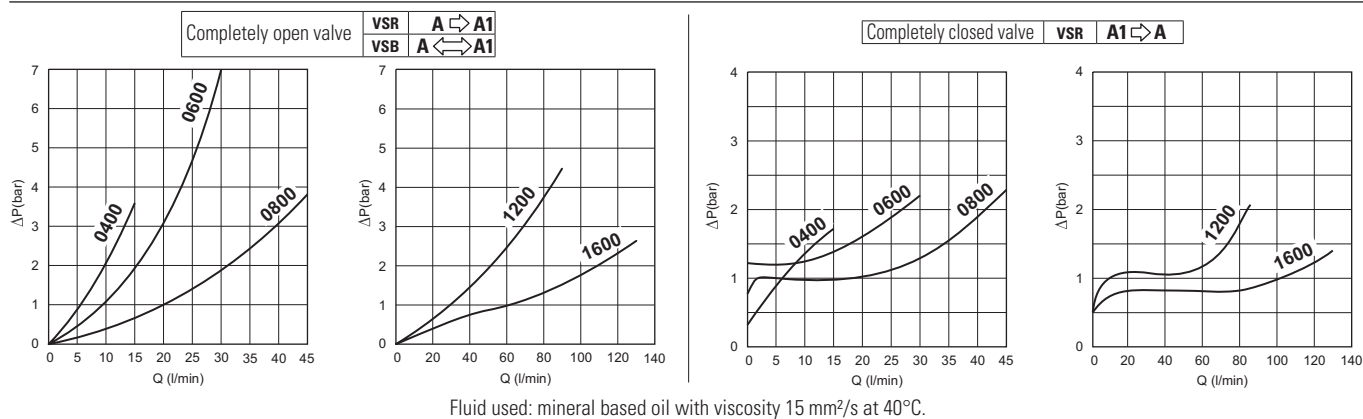

ORDERING CODE

VS* ** 00

Series Size Serial N.o.

VSR = Unidirectional flow control valve
VSB = Bidirectional flow control valve

04 = BSPP 1/4
06 = BSPP 3/8
08 = BSPP 1/2
12 = BSPP 3/4
16 = BSPP 1

UNIDIRECTIONAL AND BIDIRECTIONAL FLOW CONTROL VALVES - IN-LINE MOUNTING

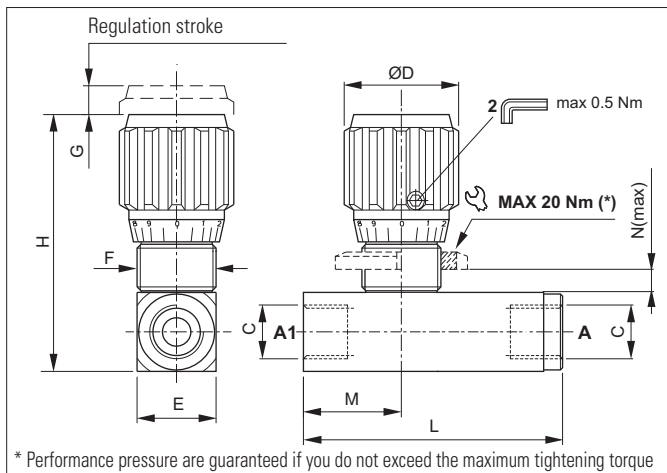

Flow control valve using non compensated throttling. The flow is reduced in only one direction (A to A1) for STU valves and in both directions for STB valves, turning the wheel with locking screw right or left. Guarantees excellent mechanical seal with negligible leakage. It has a galvanised steel body. The check valve tapered poppet is in tempered and ground steel.

HYDRAULIC FEATURES

Hydraulic fluid	DIN 51524 Mineral oils
Fluid viscosity	10 ÷ 500 mm ² /s
Fluid temperature	-25°C ÷ 75°C
Ambient temperature	-25°C ÷ 60°C
Max. contamin. level class with filter	ISO 4406:1999 - class 19/17/14

Code	C	Flow max (l/min)	Pressure max (bar)	L - STU (mm)	L - STB (mm)	H (mm)	D (mm)	E (mm)	F (mm)	G (mm)	M (mm)	N max (mm)	Weight - STU (kg)	Weight - STB (kg)	Weight screw (kg)
STU-STB 0400	1/4 BSP	20	400	73	54	68.5	31.5	20	M20x1	6	27	7	0.26	0.21	0.020
STU-STB 0600	3/8 BSP	30	400	82	62	80.5	35.5	25	M25x1.5	9.5	31	7	0.44	0.37	0.031
STU-STB 0800	1/2 BSP	50	350	98	73	93	41	30	M30x1.5	8	36.5	9	0.73	0.59	0.043
STU-STB 1200	3/4 BSP	85	320	112	84	110	47	40	M35x1.5	13	42	11	1.36	1.10	0.067
STU-STB 1600	1 BSP	150	300	142	100	121.5	47	45	M40x1.5	11.5	50	15	2	1.52	0.090

HYDRAULIC SYMBOLS

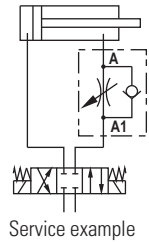
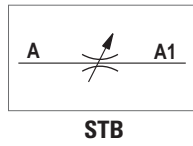
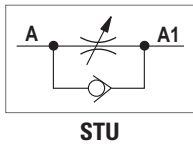

12

PRESSURE DROPS

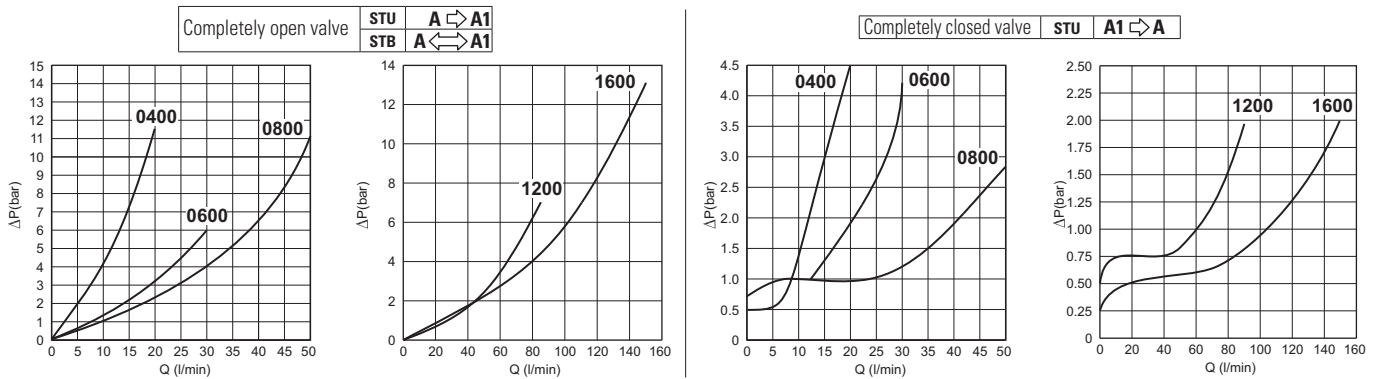

ORDERING CODE

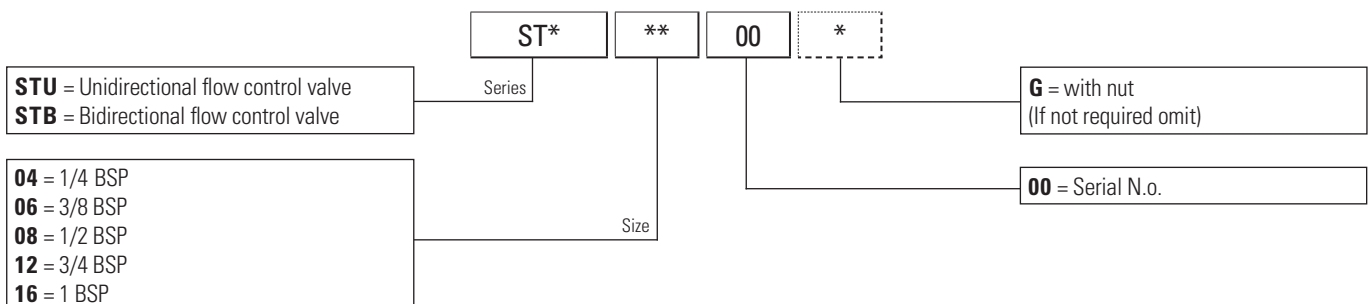

PRESSURE COMPENSATED FLOW UNIDIRECTIONAL FLOW CONTROL VALVES - IN-LINE MOUNTING

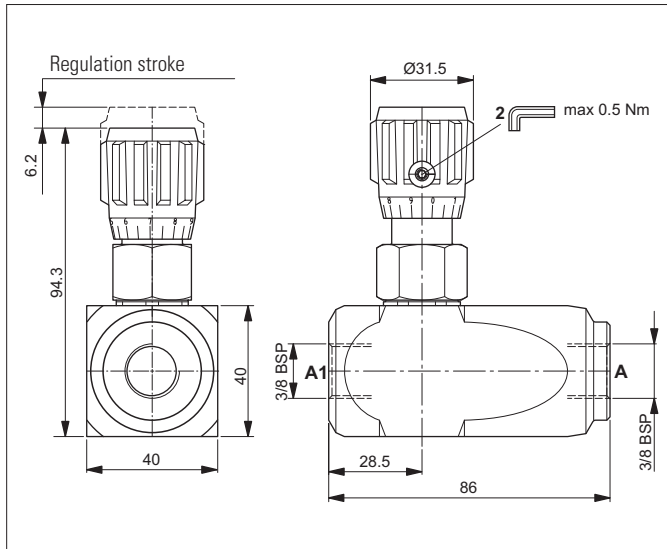

The valve maintains the flow rate in one direction (A to A1) regardless of oil pressure; the oil flows freely in the opposite direction. The flow is reduced by turning the wheel right or left. Slight leakage is tolerated when the control screw or wheel is screwed down completely. It has a galvanised steel body. The compensator plunger and check valve ball poppet are in tempered and ground steel.

HYDRAULIC FEATURES

Max. working pressure	250 bar
ΔP of regulation	12.6 bar
Max. Flow	29 l/min
Hydraulic fluid	DIN 51524 Mineral oils
Fluid viscosity	10 ÷ 500 mm ² /s
Fluid temperature	-25°C ÷ 75°C
Ambient temperature	-25°C ÷ 60°C
Max. contamin. level class with filter	ISO 4406:1999 - class 19/17/14
Weight	0.95 kg

HYDRAULIC SYMBOL

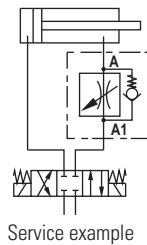
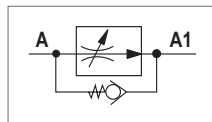

PRESSURE DROPS

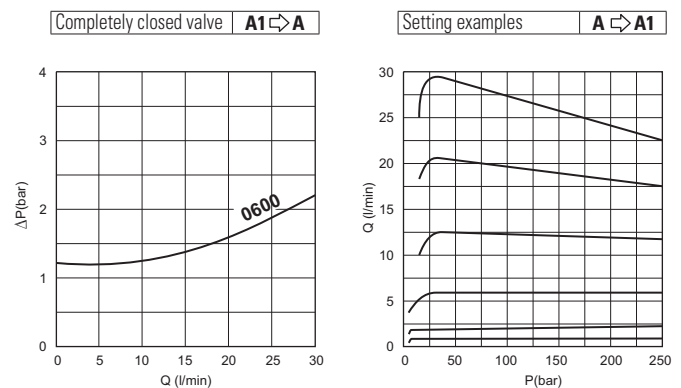

Fluid used: mineral based oil with viscosity 32 mm²/s at 40°C.

ORDERING CODE

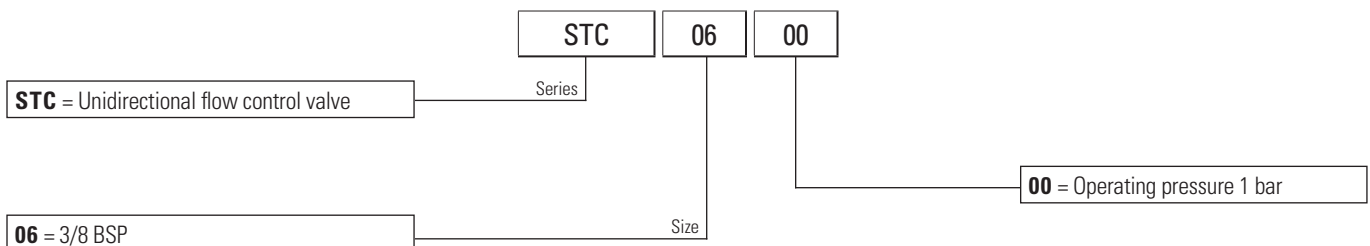

HAND PUMPS

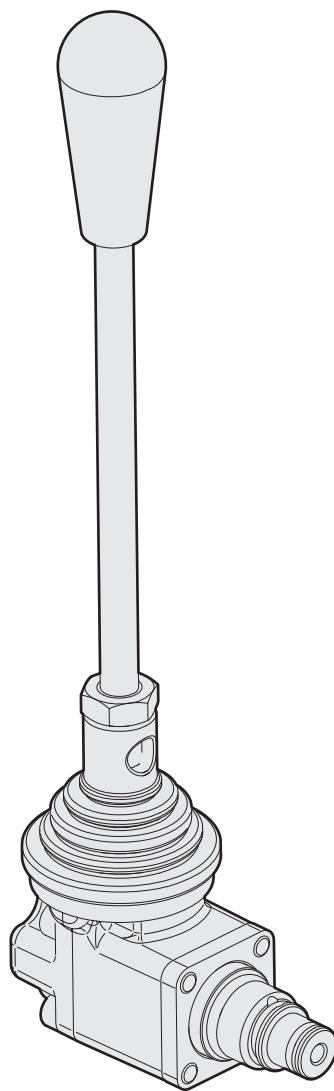

HAND PUMPS

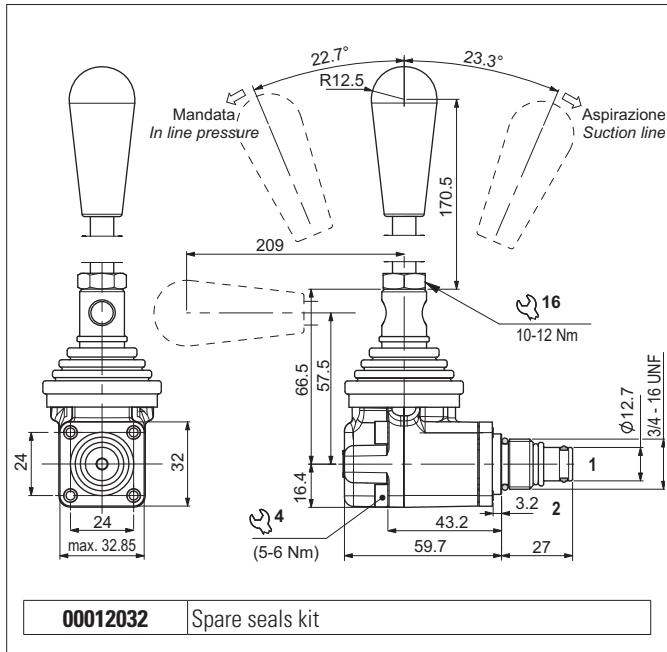

This hand pump handles emergencies manually in small systems. Available in 1cc/pump stroke and 2cc/pump stroke displacement versions. The lever body is in diecast aluminium. The cartridge is steel with tempered and ground steel ball check valves.

HYDRAULIC FEATURES

Max. working pressure	CPM041 = 300 bar CPM042 = 160 bar
Displacement	CPM041 = 1 cc stroke CPM042 = 2 cc stroke
Working Temperature	-25°C ÷ 60°C
Max. Leakage (0 ÷ 5 drops/min)	0 ÷ 0.25 cm ³ /min
Hydraulic fluid	DIN 51524 Mineral oils
Fluid viscosity	10 ÷ 500 mm ² /s
Fluid temperature	-25°C ÷ 75°C
Max. contamin. level class with filter	ISO 4406:1999 - class 19/17/14
Weight	0.41 kg
Tightening torque	25 ÷ 30 Nm
Cavity (3/4 - 16 UNF)	CD018006 (See section 17)

HYDRAULIC SYMBOL

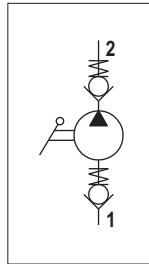

OPERATION FORCE ON THE LEVER

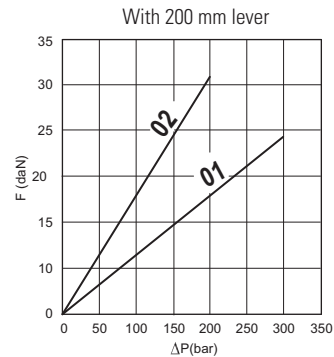

Fluid used: mineral based oil with viscosity 32 mm²/s at 40°C.

ORDERING CODE

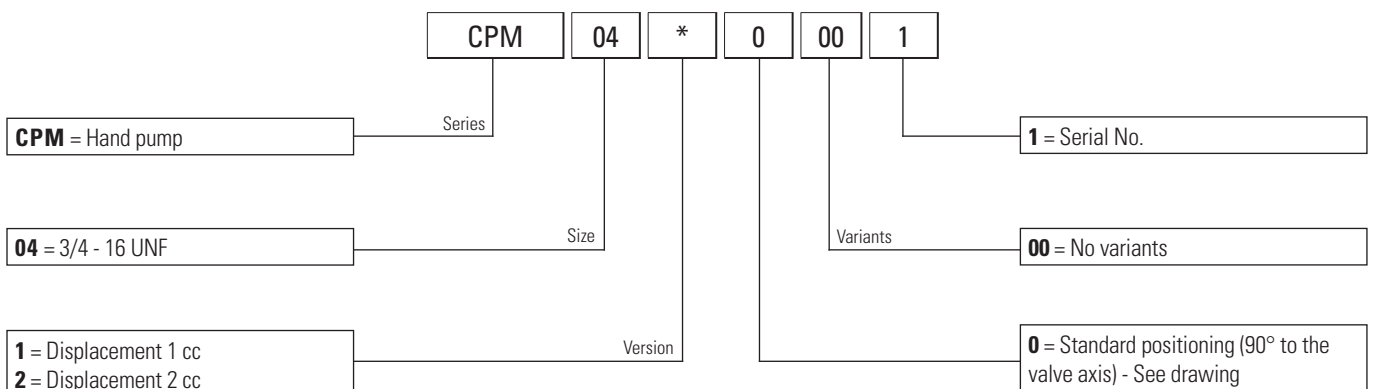

VALVE HOUSINGS

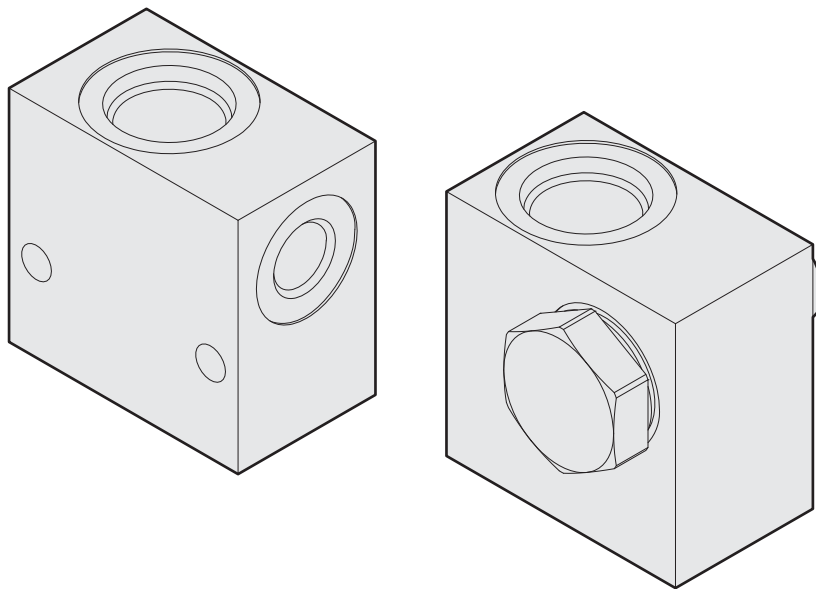

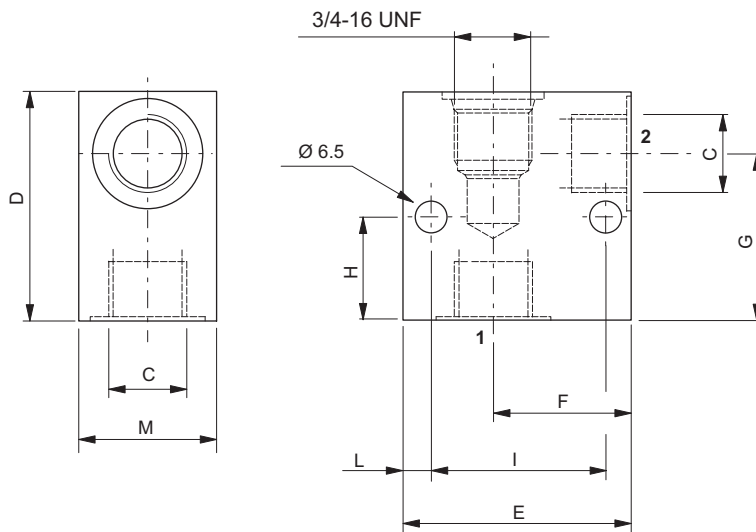

Code	C	D (mm)	E (mm)	F (mm)	G (mm)	H (mm)	I (mm)	L (mm)	M (mm)	Material	Cavity
F07100013	1/4 BSP	46	50	30,5	33	18	38	6	30	Alluminio EN AW 2011	CD018006
M18400061	3/8 BSP	55	60	38	41,25	25	45	7,5	30		
M18400071	1/2 BSP	60	60	35	41	6	48	6	40		

14

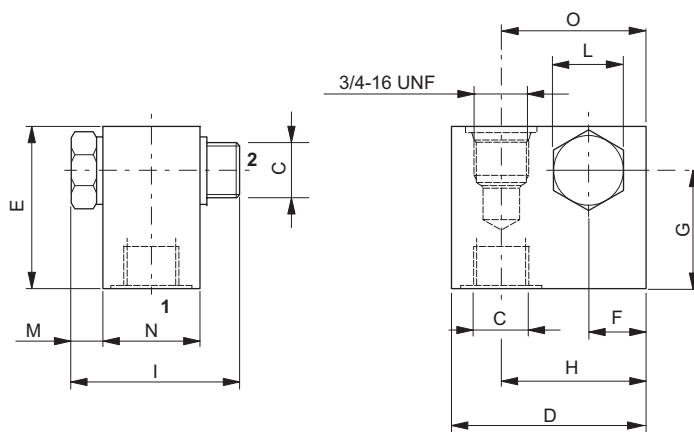

Code	C	D (mm)	E (mm)	F (mm)	G (mm)	H (mm)	I (mm)	L (mm)	M (mm)	N (mm)	O (mm)	Material	Cavity
17030532	3/8 BSP	50	50	16	32	35	51	22	9	30	34.5	Alluminium EN AW 2011	CD018006
V10500034	1/4 BSP	40	46	11	31	26	49	19	8	30	26		

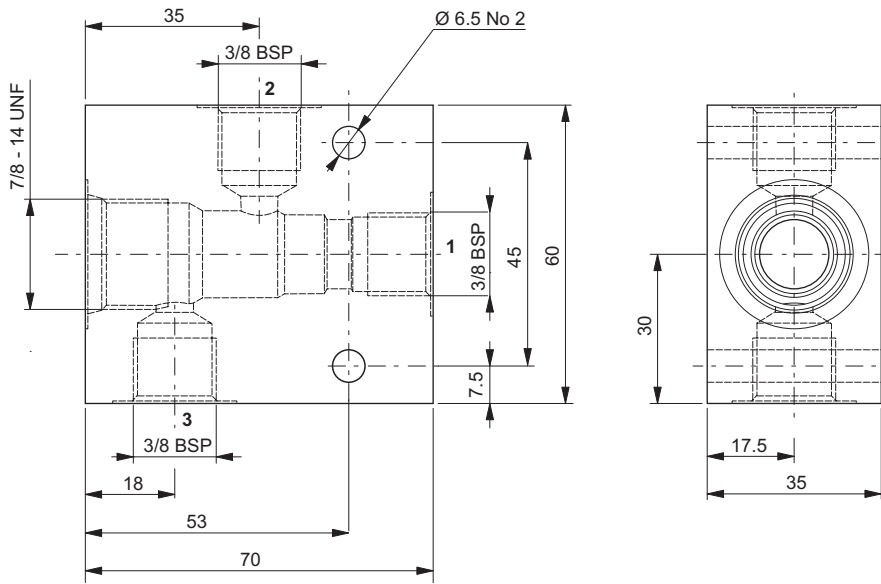

Code	Material	Cavity
M10850319	Alluminium - EN AW 2011	CD019006

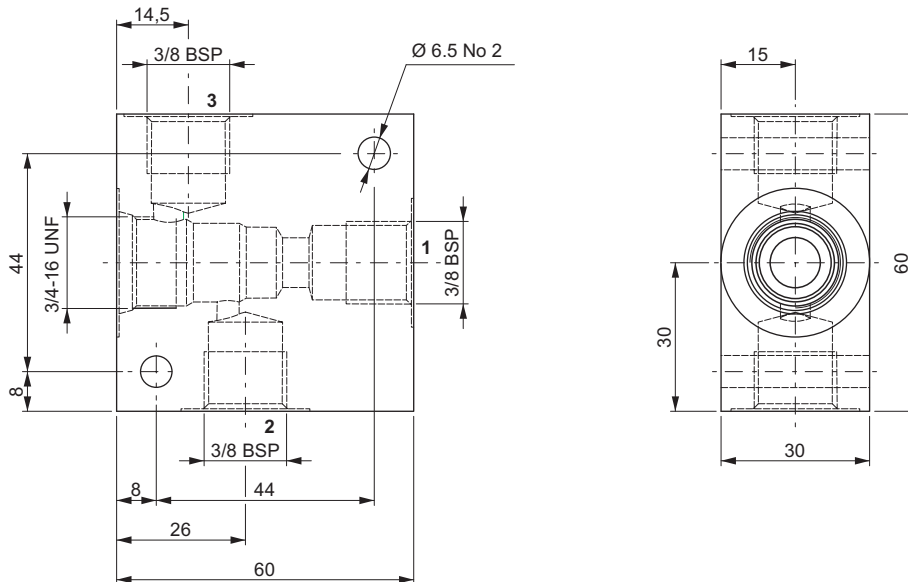

Code	Material	Cavity
M10850206	Alluminium - EN AW 2011	CD018005

CAVITIES

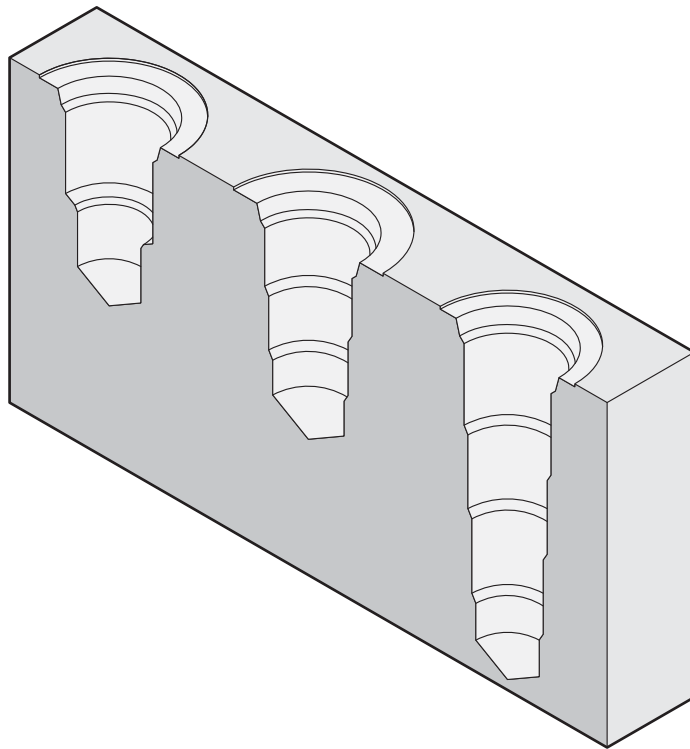

CA012001 **1/4 BSP**

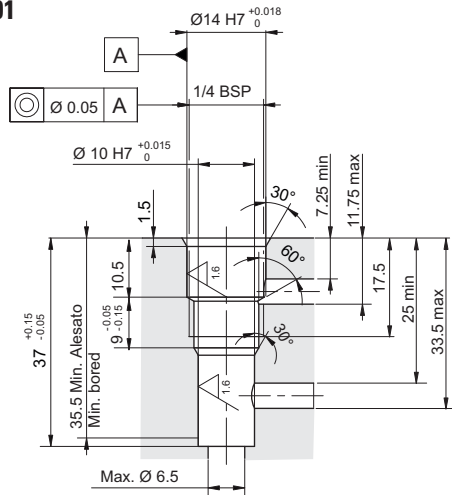

Plugs compatibility:

--	--	--	--	--

CD018001 **3/4 16UNF**

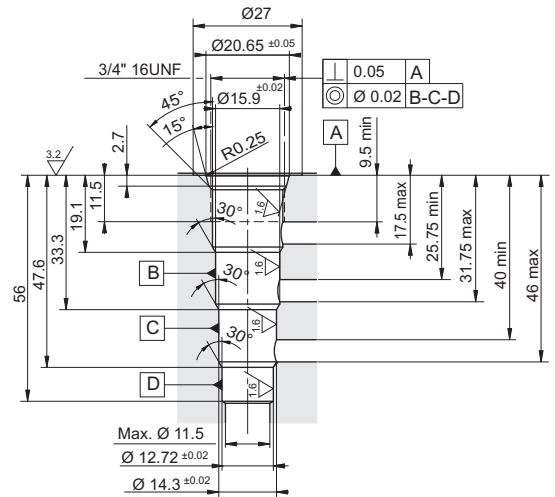

Plugs compatibility:

R78150114	R78150109	R78150111		
-----------	-----------	-----------	--	--

CD018003 **3/4 16UNF**

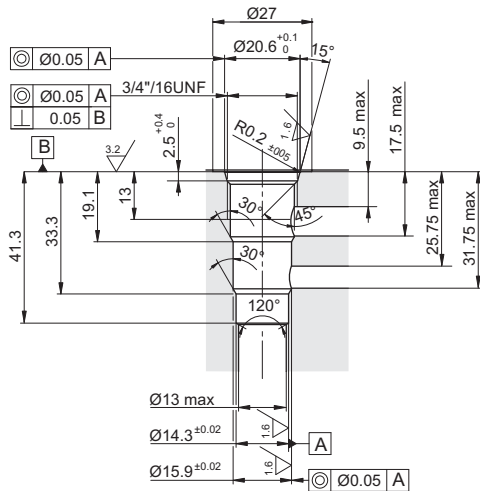

Plugs compatibility:

20001700	20001900			
----------	----------	--	--	--

CD018005 **3/4 16UNF**

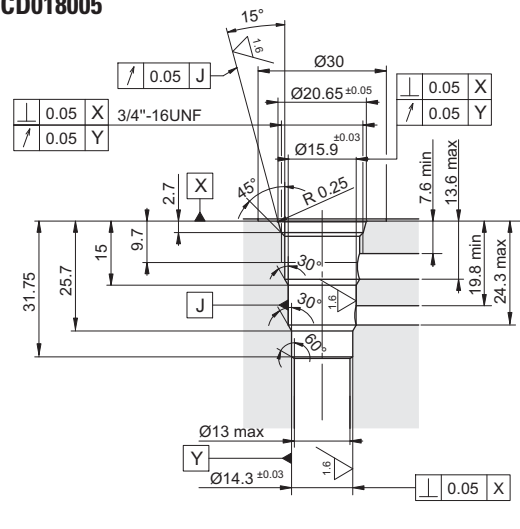

Plugs compatibility:

--	--	--	--	--

CD018006 **3/4 16UNF**

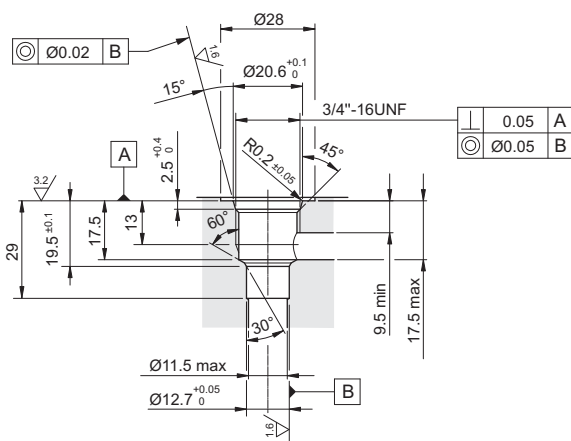

Plugs compatibility:

20001900	20001700	20003800	20009400	20018000
----------	----------	----------	----------	----------

CD018009 **3/4 16UNF**

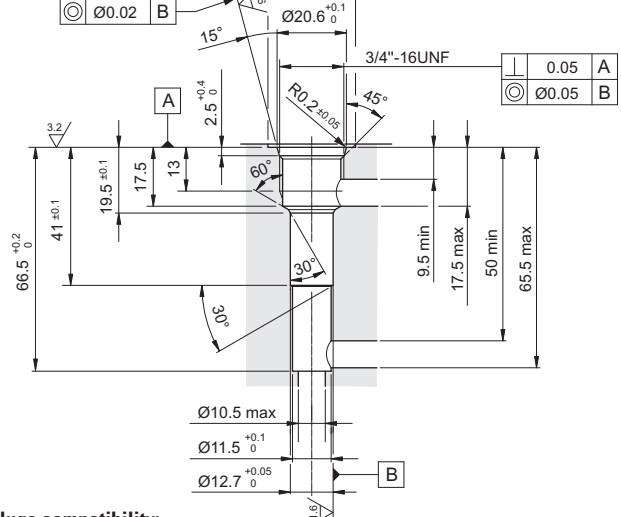

Plugs compatibility:

20001900	20001700	20003800	20009400	20018000
----------	----------	----------	----------	----------

15

CD018012

3/4 16UNF

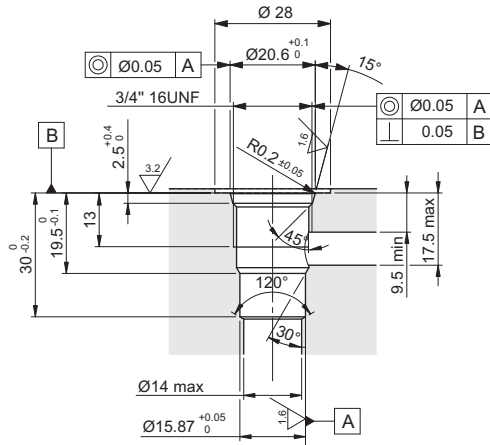

Plugs compatibility:

R78200A19	20001700	20001900		
-----------	----------	----------	--	--

CD018013

3/4 16UNF

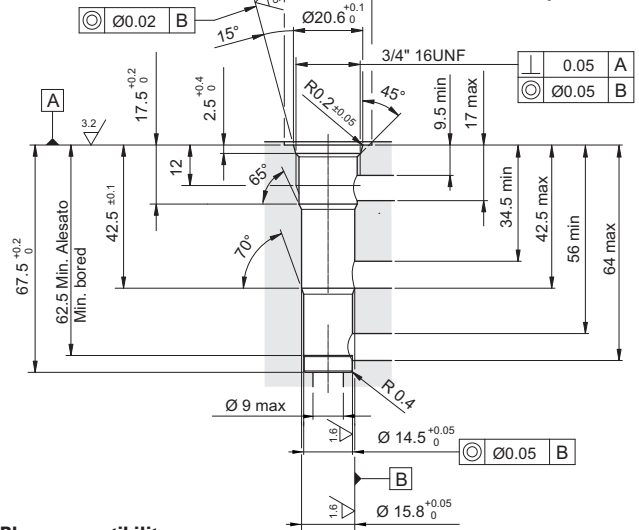

Plugs compatibility:

R78150100				
-----------	--	--	--	--

CD018014

3/4 16UNF

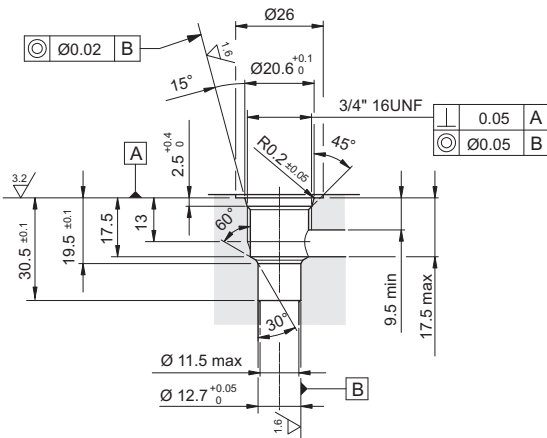

Plugs compatibility:

20001900	20001700	20003800	20009400	20018000
----------	----------	----------	----------	----------

CD018015

3/4 16UNF

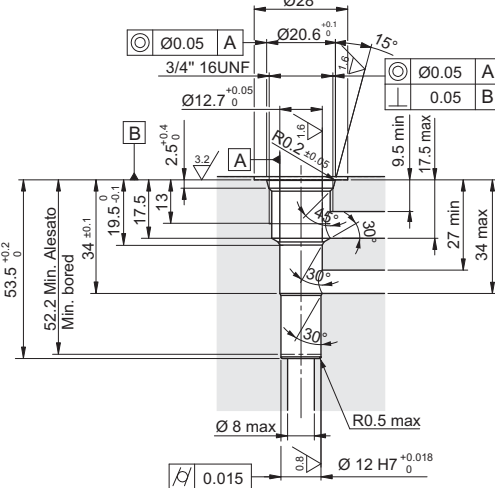

Plugs compatibility:

20018000	20001700	20001900	20003800	20009400
----------	----------	----------	----------	----------

CD018016

3/4 16UNF

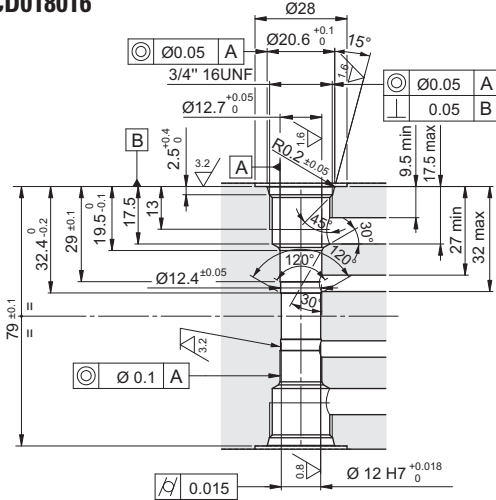

Plugs compatibility:

20018000	20001700	20001900	20003800	20009400
----------	----------	----------	----------	----------

CD019006

7/8 14UNF

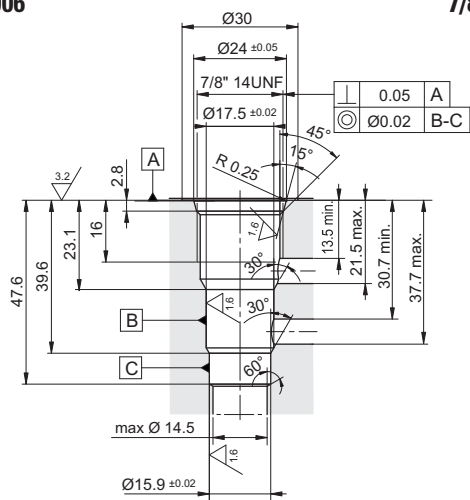

Plugs compatibility:

--	--	--	--	--

CD019007

7/8 14UNF

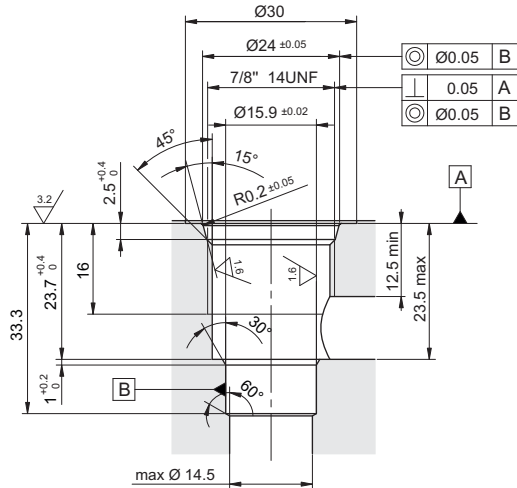

Plugs compatibility:

R78100033				
-----------	--	--	--	--

CD019011

7/8 14UNF

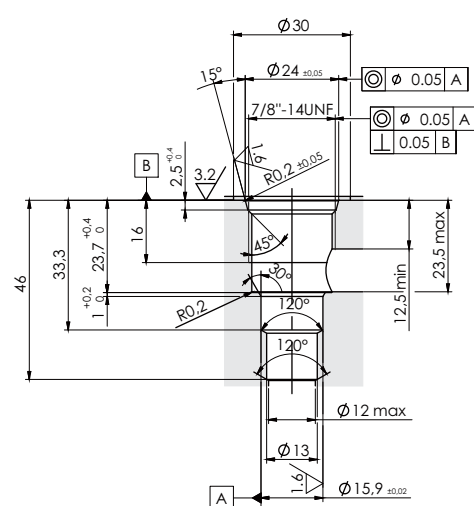

Plugs compatibility:

R78100033				
-----------	--	--	--	--

CG001002

1/8 BSP

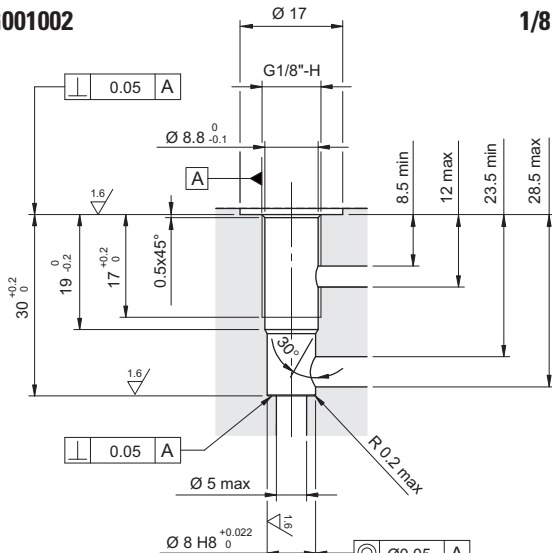

Plugs compatibility:

--	--	--	--	--

CG003004

3/8 BSP

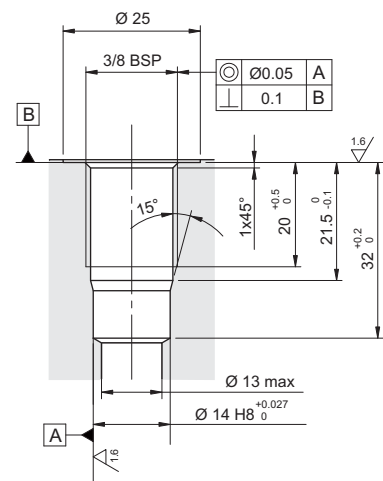

Plugs compatibility:

--	--	--	--	--

CA007001

M8X1

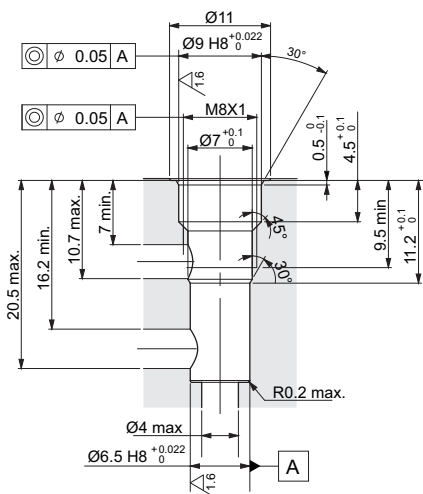

Plugs compatibility:

--	--	--	--	--

CN019002

M10X1

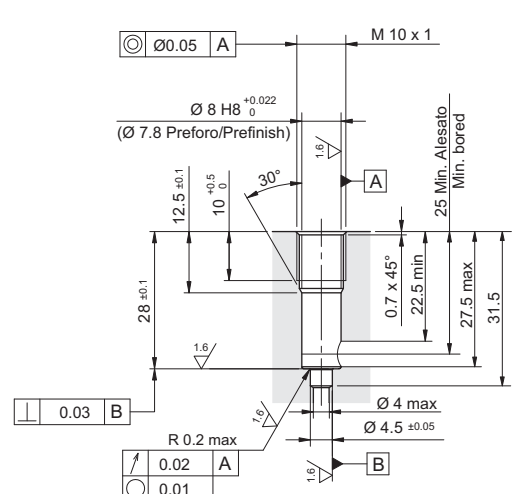

Plugs compatibility:

--	--	--	--	--

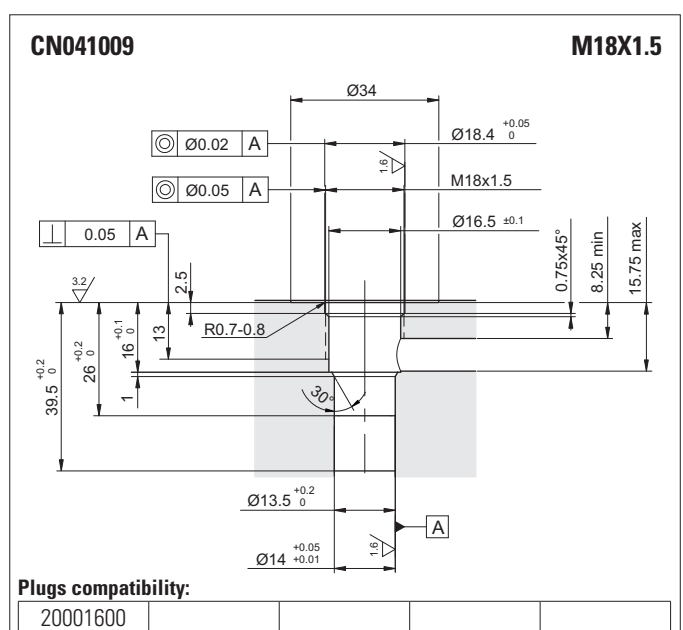
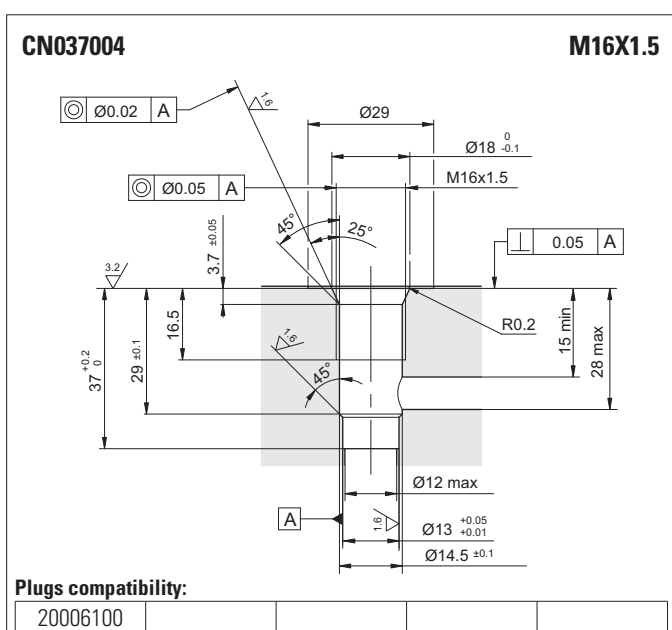
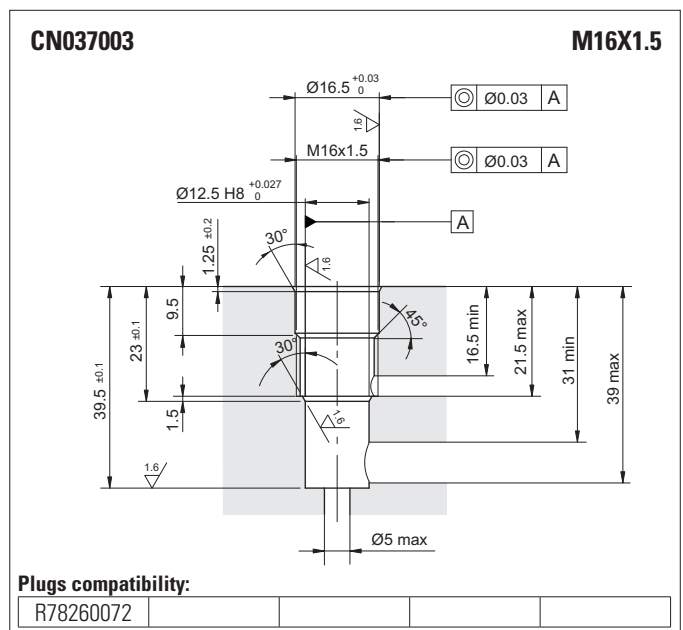
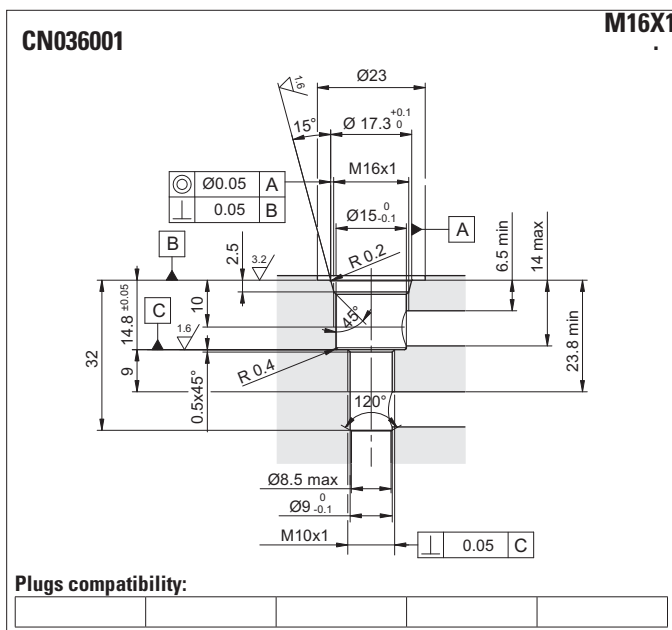
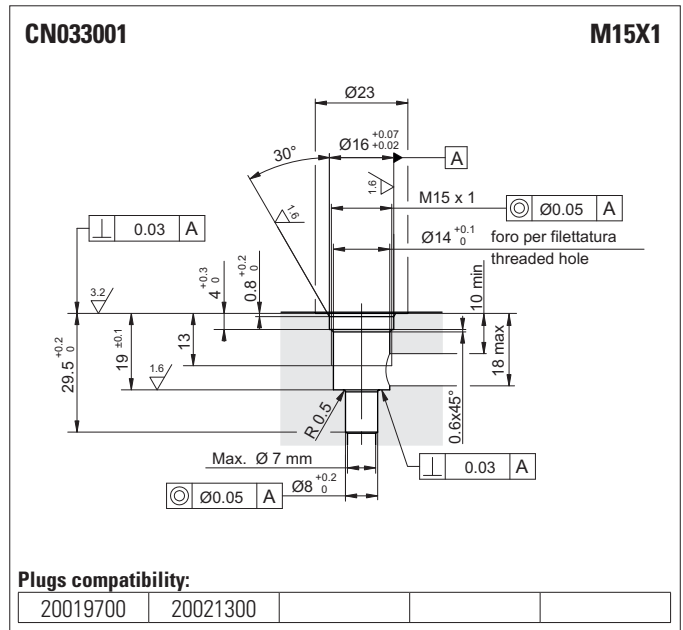
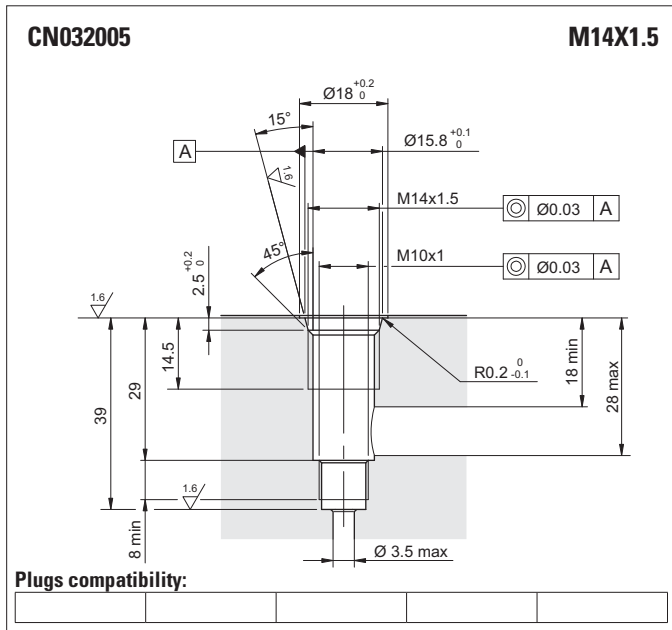

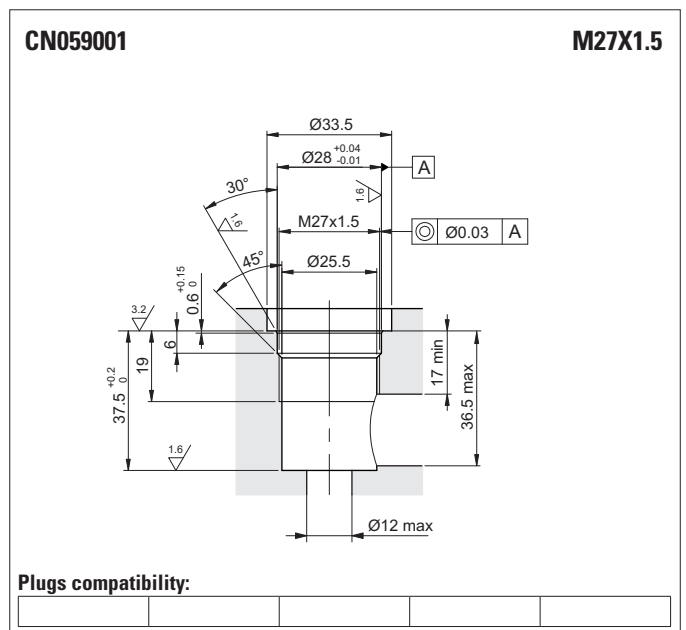
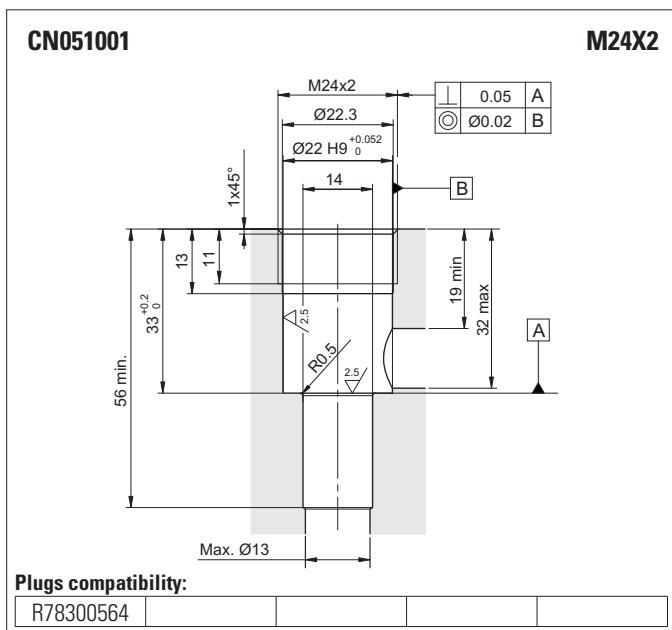
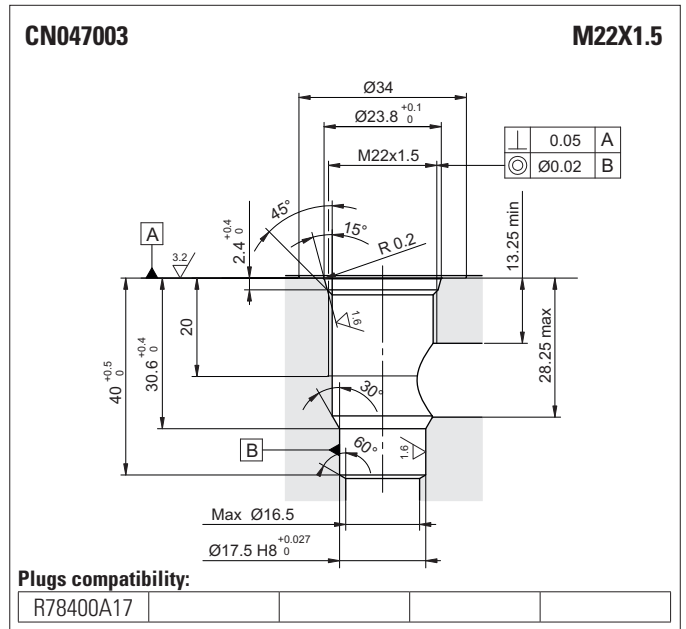
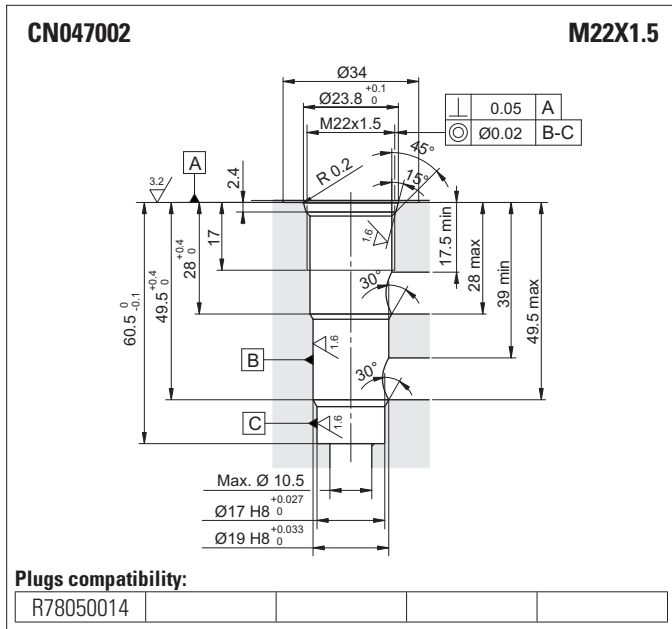
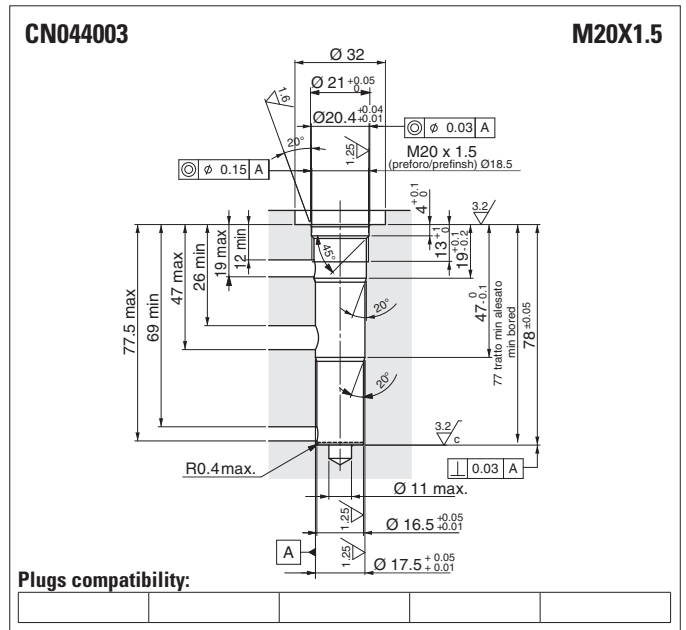
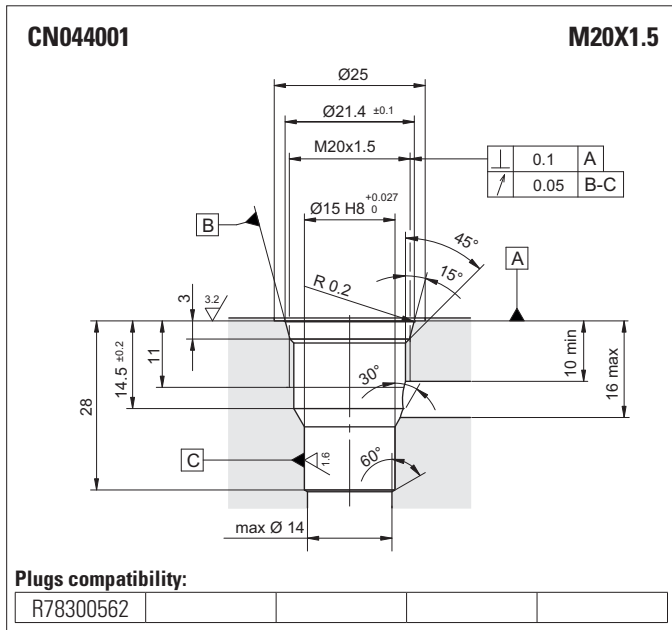

CN070001

M33X2

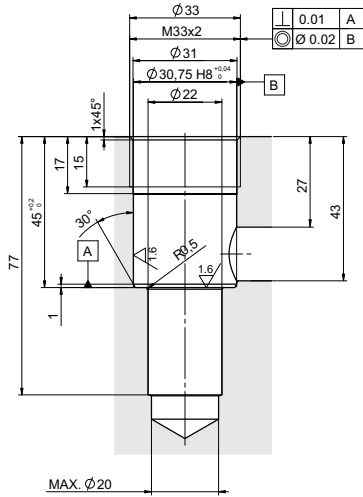

Plugs compatibility:

R78400568				
-----------	--	--	--	--

Plugs compatibility:

--	--	--	--	--

Plugs compatibility:

--	--	--	--	--

Plugs compatibility:

--	--	--	--	--

Plugs compatibility:

--	--	--	--	--

Plugs compatibility:

--	--	--	--	--

STANDARD PLUGS

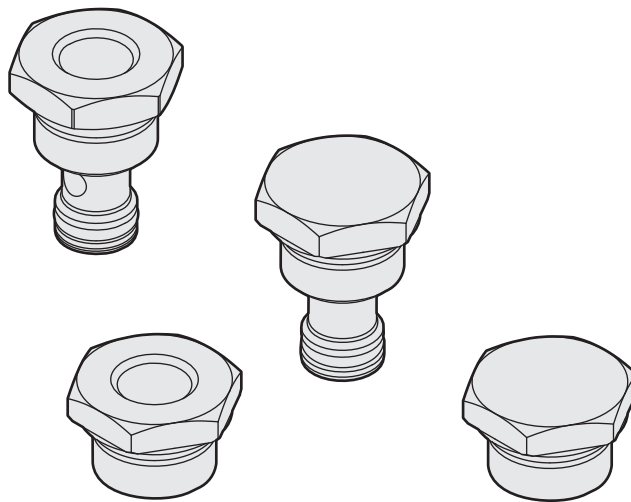

Standard plugs

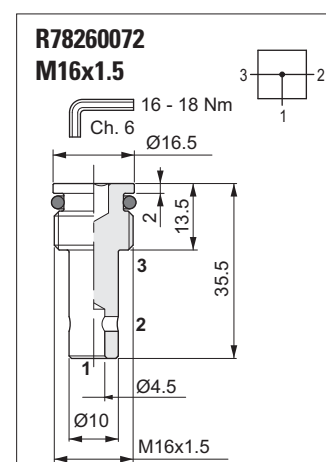
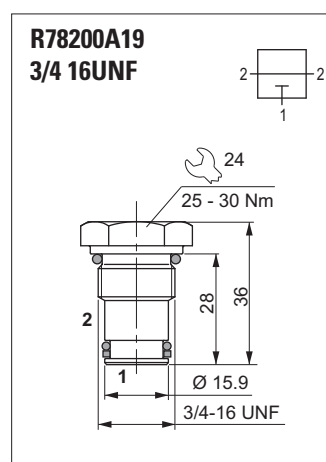
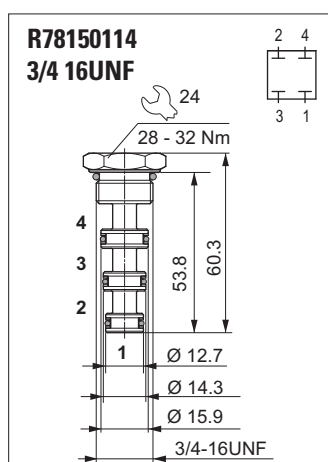
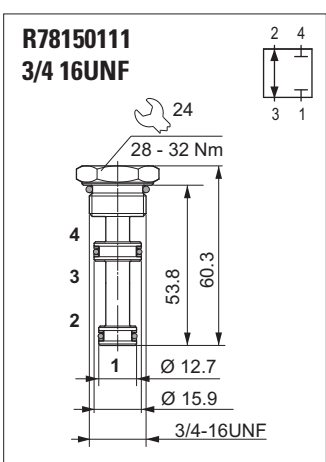
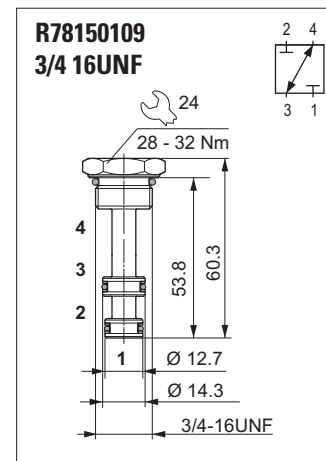
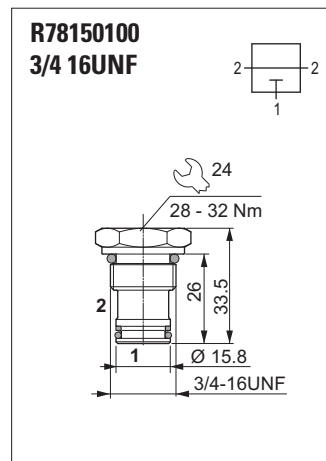
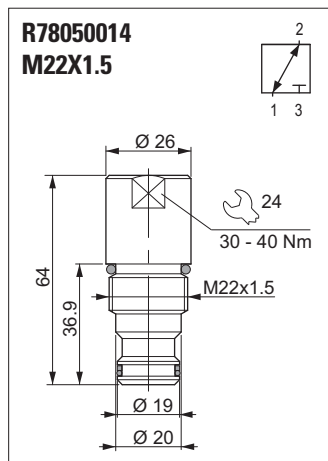
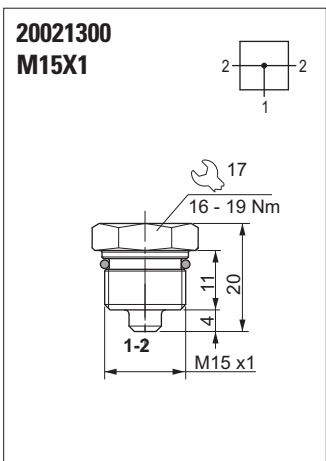
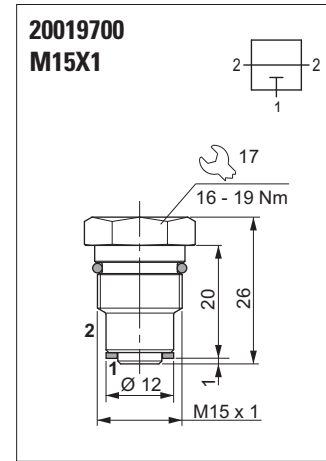
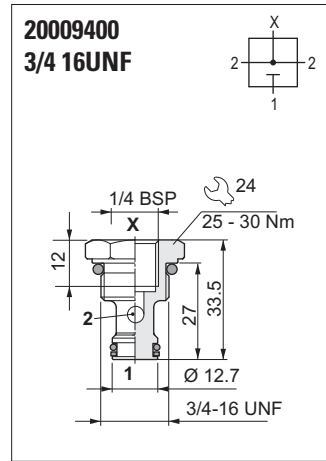
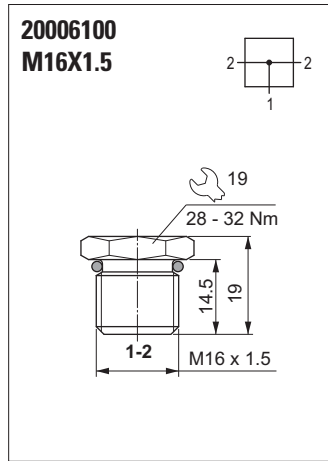
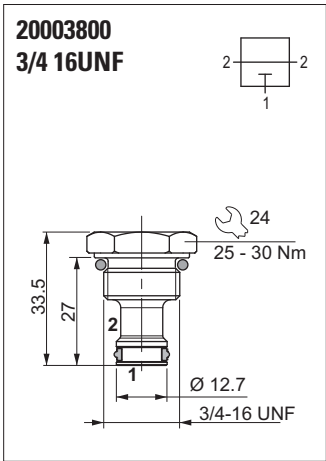
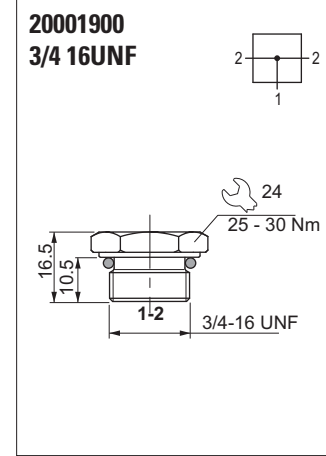
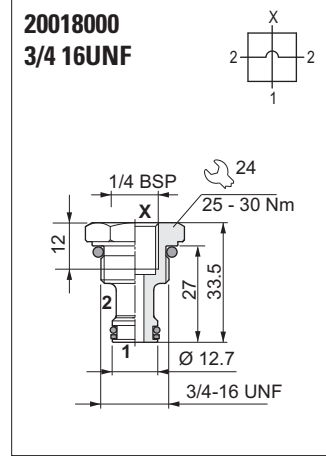
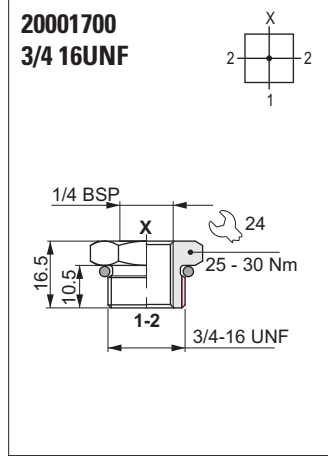
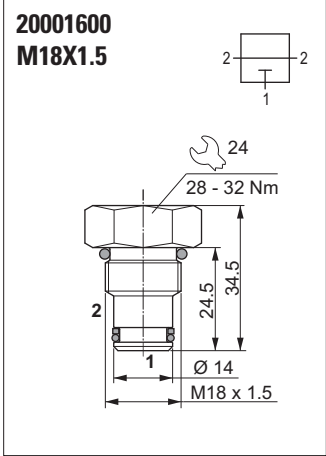

16

Standard plugs

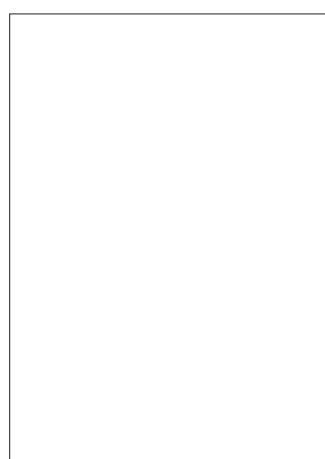
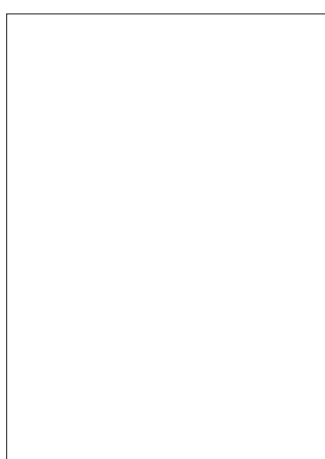
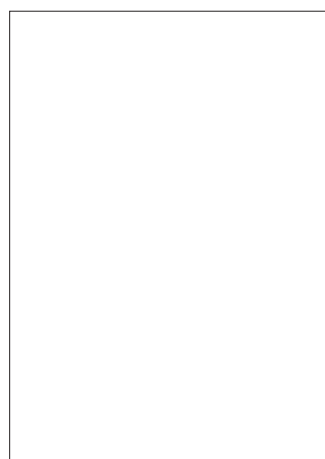
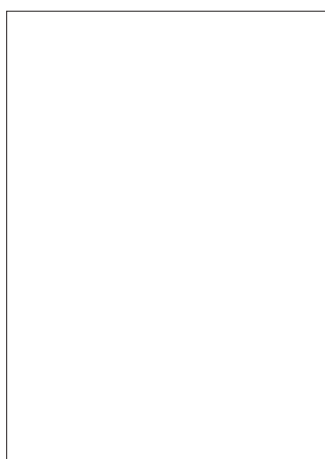
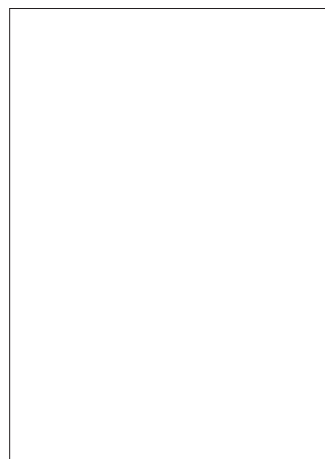
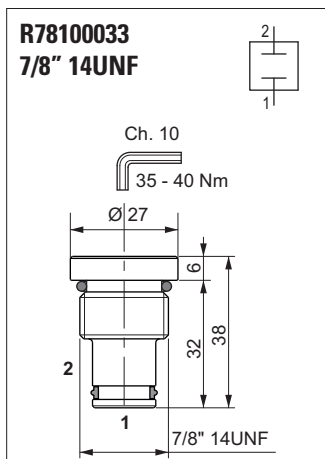
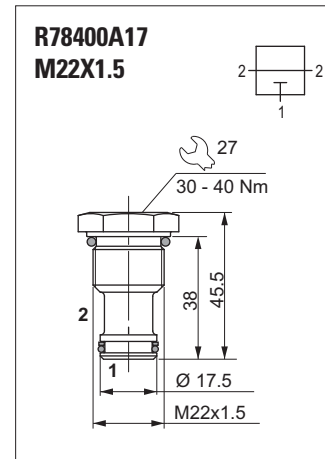
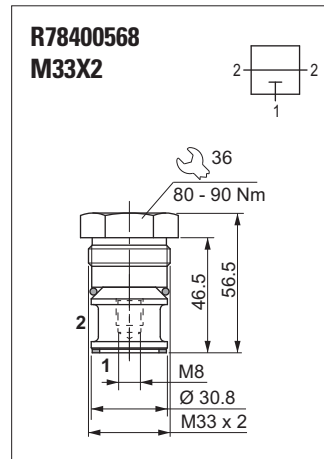
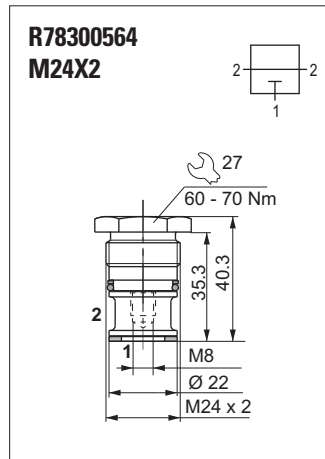
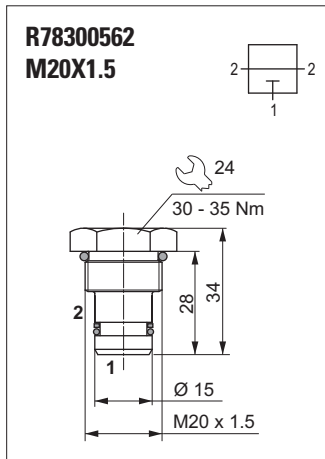

COILS

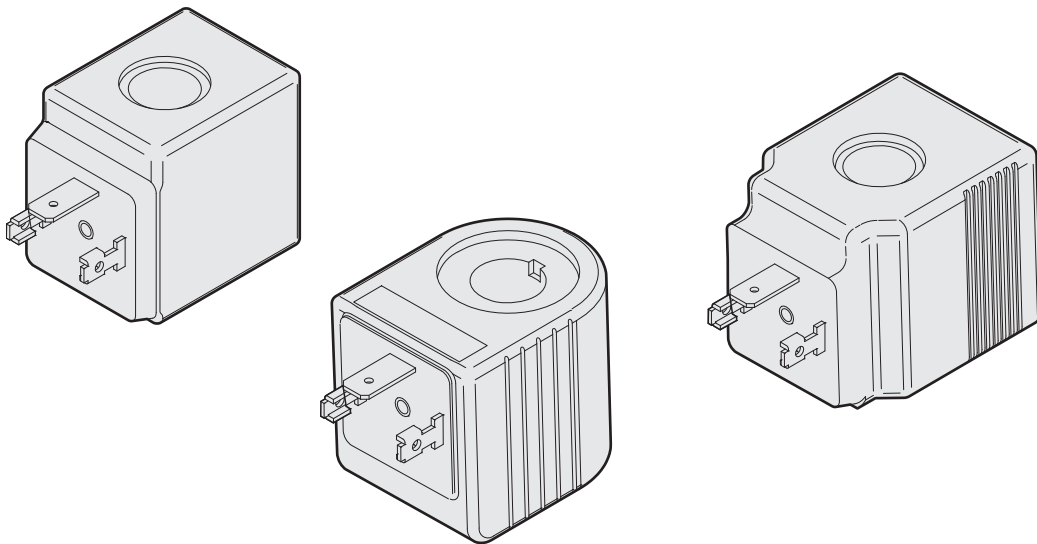

C30 - COILS 18W

Type of protection	IP 65
Number of cycle	18000/h
Supply tolerance	±10%
Ambient temperature	-30°C ÷ 60°C

Duty cycle	100% ED
Insulation class wire	H
Weight	0.141 kg

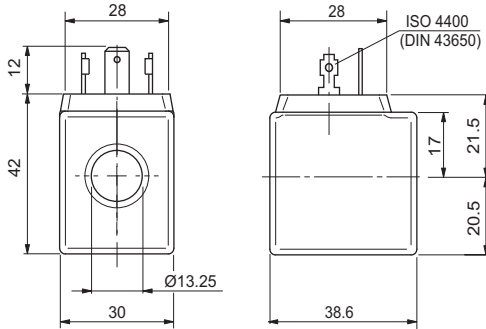

Standard (Hirschmann ISO 4400 DIN43650)

Coil		Max winding temperature (1)	Rated power	Resistance ±7% (2)	Spare code
Code	Voltage				
L	12 VDC	110 °C	18 W	7.7 Ω	M14000001
M	24 VDC	110 °C	18 W	31 Ω	M14000002
N	48 VDC	110 °C	18 W	116 Ω	M14000003
2	21.6 VDC	110 °C	18 W	27 Ω	M14000009
Z	102 VDC (3)	110 °C	18 W	578 Ω	M14000006
X	205 VDC (3)	110 °C	18 W	2627 Ω	M14000007
A	24 VAC/50 Hz	100 °C	35 VA	5.3 Ω	M14001002
J	115 VAC/50 Hz (3)	100 °C	35 VA	108 Ω	M14001004
I	230 VAC/50 Hz (3)	100 °C	35 VA	438 Ω	M14001005
F	24 VAC/60 Hz	100 °C	35 VA	3.8 Ω	M14001012
C	110 VAC/60 Hz (3)	100 °C	35 VA	92 Ω	M14001014
D	220 VAC/60 Hz (3)	100 °C	35 VA	375 Ω	M14001015

(1) Ambient temperature 25 °C - (2) Ambient temperature 20 °C

(3) The european low voltage directive is applied to electronical equipments used at a nominal voltages between 50 and 1000 VAC or 75 and 1500 VDC. In conformity with the low directive each part of the manifold or the subplate on which the valve is mounted should be connected to a protective earth with a resistance less than 0.1 ohms.

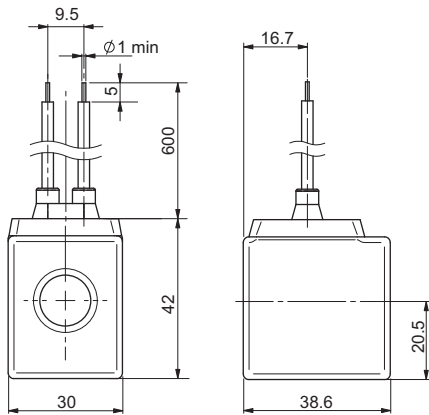

With wires (variant FK)

Coil		Max winding temperature (1)	Rated power	Resistance ±7% (2)	Spare code
Code	Voltage				
L	12 VDC	110 °C	18 W	7.7 Ω	M14000101
M	24 VDC	110 °C	18 W	31 Ω	M14000102

(1) Ambient temperature 25 °C - (2) Ambient temperature 20 °C

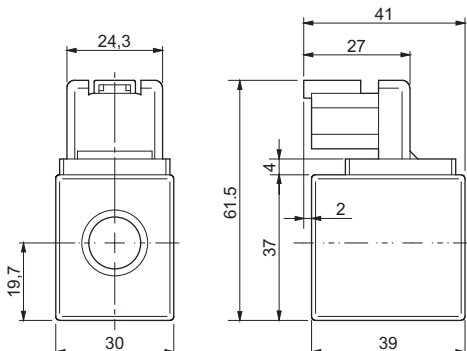

DEUTSCH and bidirectional integrated diode (variant CX)

Coil		Max winding temperature (1)	Rated power	Resistance ±7% (2)	Spare code
Code	Voltage				
L	12 VDC	110 °C	18 W	7.7 Ω	M14760001
M	24 VDC	110 °C	18 W	31 Ω	M14760002

(1) Ambient temperature 25 °C - (2) Ambient temperature 20 °C

C36 - COILS 22W

Type of protection	IP 65
Number of cycle	18000/h
Supply tolerance	±10%
Ambient temperature	-30°C ÷ 60°C

Duty cycle	100% ED
Insulation class wire	H
Weight	0.2 kg

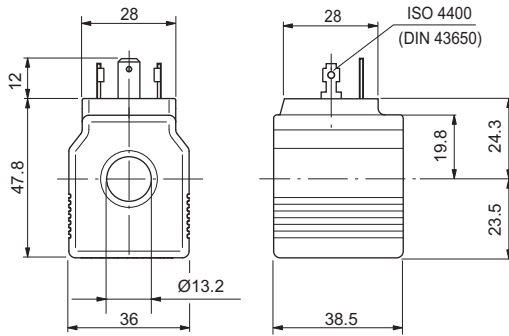

Standard (Hirschmann ISO 4400 DIN43650)

Coil		Max winding temperature (1)	Rated power	Resistance ±7% (2)	Spare code
Code	Voltage				
L	12 VDC	115 °C	22 W	6.3 Ω	M14040001
4	14 VDC	115 °C	22 W	8.9 Ω	M14040009
M	24 VDC	115 °C	22 W	25.6 Ω	M14040002
V	28 VDC	115 °C	22 W	32.8 Ω	M14040008
N	48 VDC	115 °C	22 W	102 Ω	M14040003
2	21.6 VDC	115 °C	22 W	20.2 Ω	M14040000
Z	102 VDC (3)	115 °C	22 W	467.85 Ω	M14040006
X	205 VDC (3)	115 °C	22 W	1954 Ω	M14040007

(1) Ambient temperature 25 °C - (2) Ambient temperature 20 °C

(3) The european low voltage directive is applied to electronical equipments used at a nominal voltages between 50 and 1000 VAC or 75 and 1500 VDC. In conformity with the low directive each part of the manifold or the subplate on which the valve is mounted should be connected to a protective earth with a resistance less than 0.1 ohms.

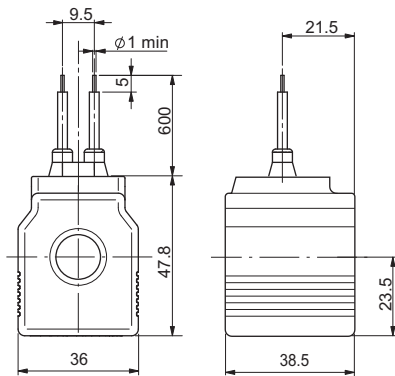

With wires (variant FK)

Coil		Max winding temperature (1)	Rated power	Resistance ±7% (2)	Spare code
Code	Voltage				
L	12 VDC	115 °C	22 W	6.3 Ω	M14040101
4	14 VDC	115 °C	22 W	8.9 Ω	M14040109
M	24 VDC	115 °C	22 W	25.6 Ω	M14040102
V	28 VDC	115 °C	22 W	32.8 Ω	M14040108

(1) Ambient temperature 25 °C - (2) Ambient temperature 20 °C

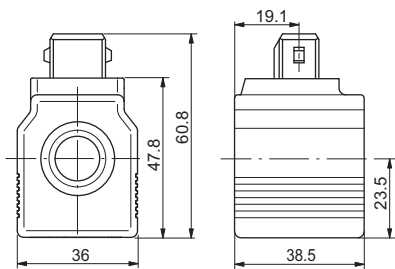

AMP Junior (variant AJ)

Coil		Max winding temperature (1)	Rated power	Resistance ±7% (2)	Spare code
Code	Voltage				
L	12 VDC	115 °C	22 W	6.3 Ω	M14730001
M	24 VDC	115 °C	22 W	25.6 Ω	M14730002

(1) Ambient temperature 25 °C - (2) Ambient temperature 20 °C

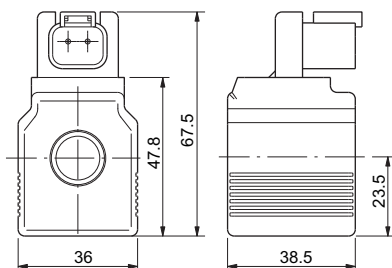

Deutsch + bidirectional diode - DT04-2P (connection D / variant CX)

Coil		Max winding temperature (1)	Rated power	Resistance ±7% (2)	Spare code
Code	Voltage				
L	12 VDC	115 °C	22 W	6.3 Ω	M14040201
4	14 VDC	115 °C	22 W	8.9 Ω	M14040209
M	24 VDC	115 °C	22 W	25.6 Ω	M14040202
V	28 VDC	115 °C	22 W	32.8 Ω	M14040208

(1) Ambient temperature 25 °C - (2) Ambient temperature 20 °C

A09 - COILS 27W

Type of protection	IP 65
Number of cycle	18000/h
Supply tolerance	±10%
Ambient temperature	-30°C ÷ 50°C

Duty cycle	100% ED
Insulation class wire	H
Weight	0.215 kg

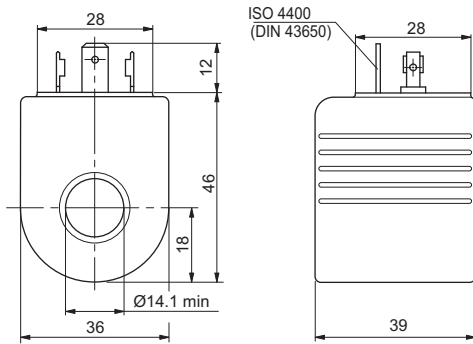

Hirschmann ISO 4400 DIN43650 (connection H)

Code	Coil		Max winding temperature (1)	Rated power	Resistance ±7% (2)	Spare code
	Voltage					
L	12 VDC		123 °C	27 W	5.3 Ω	M14310001
M	24 VDC		123 °C	27 W	21.3 Ω	M14310002
N	48 VDC		123 °C	27 W	85.3 Ω	M14310003
Z	102 VDC (3)		123 °C	27 W	392 Ω	M14310008
P	110 VDC (3)		123 °C	27 W	448 Ω	M14310005
X	205 VDC (3)		123 °C	27 W	1577 Ω	M14310009

(1) Ambient temperature 25 °C - (2) Ambient temperature 20 °C

(3) The european low voltage directive is applied to electronical equipments used at a nominal voltages between 50 and 1000 VAC or 75 and 1500 VDC. In conformity with the low directive each part of the manifold or the subplate on which the valve is mounted should be connected to a protective earth with a resistance less than 0.1 ohms.

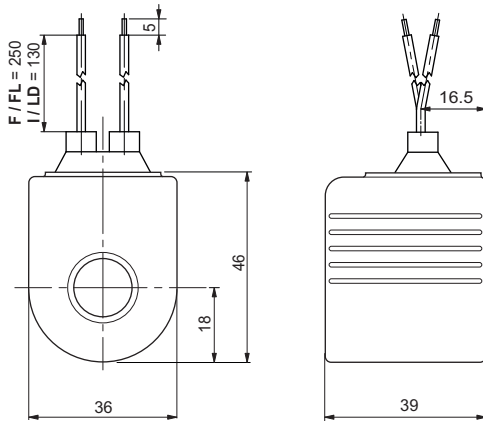

With wires and integrated bidirectional diode (connection F-I / variants FL-LD)

Codice	Bobina		Wires (mm)	Max winding temperature (1)	Rated power	Resistance ±7% (2)	Spare code
	Tensione						
L	12 VDC		F = 250	123 °C	27 W	5.3 Ω	M14070011
M	24 VDC		F = 250	123 °C	27 W	21.3 Ω	M14070012
L	12 VDC		I = 130	123 °C	27 W	5.3 Ω	M14330001
M	24 VDC		I = 130	123 °C	27 W	21.3 Ω	M14330002

(1) Ambient temperature 25 °C - (2) Ambient temperature 20 °C

17

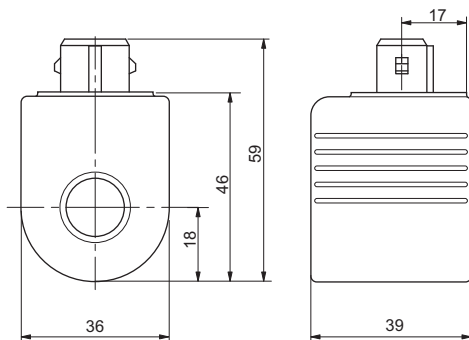

AMP Junior (connection A / variant AJ)

Code	Coil		Max winding temperature (1)	Rated power	Resistance ±7% (2)	Spare code
	Voltage					
L	12 VDC		123 °C	27 W	5.3 Ω	M14320001
M	24 VDC		123 °C	27 W	21.3 Ω	M14320002

(1) Ambient temperature 25 °C - (2) Ambient temperature 20 °C

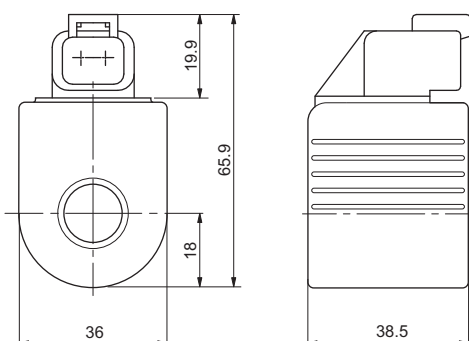

Deutsch + bidirectional diode - DT04-2P (connection D / variant CX)

Code	Coil		Max winding temperature (1)	Rated power	Resistance ±7% (2)	Spare code
	Voltage					
L	12 VDC		123 °C	27 W	5.3 Ω	M14340001
M	24 VDC		123 °C	27 W	21.3 Ω	M14340002

(1) Ambient temperature 25 °C - (2) Ambient temperature 20 °C

A12 - COILS 23W

Type of protection	IP 65
Number of cycle	18000/h
Supply tolerance	±10%
Ambient temperature	-30°C ÷ 60°C

Duty cycle	100% ED
Insulation class wire	H
Weight	0.22 kg

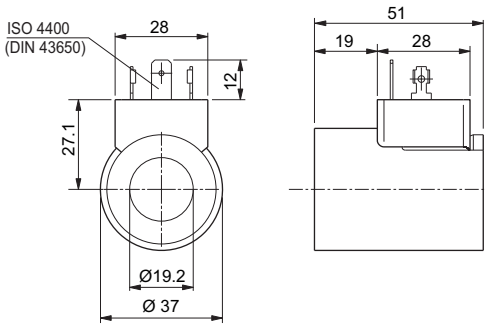

Standard (Hirschmann ISO 4400 DIN43650)

Coil		Max winding temperature (1)	Rated power	Resistance ±5% (2)	Spare code
Code	Voltage				
F	12 VDC	115 °C	23 W	5.3 Ω	M14850001
G	24 VDC	115 °C	23 W	25.3 Ω	M14850002

(1) Ambient temperature 25 °C - (2) Ambient temperature 20 °C

D12 - COILS 30W

Type of protection	IP 65
Number of cycle	18000/h
Supply tolerance	±10%
Ambient temperature	-30°C ÷ 60°C

Duty cycle	100% ED
Insulation class wire	H
Weight	0.2 kg

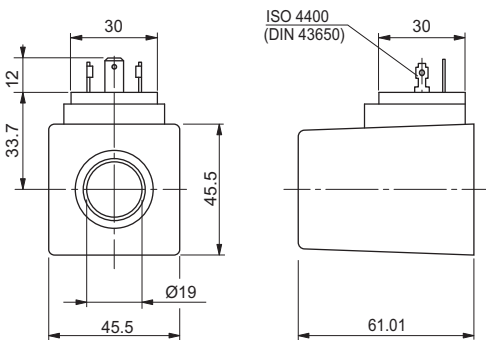

Standard (Hirschmann ISO 4400 DIN43650)

Coil		Max winding temperature (1)	Rated power	Resistance ±7% (2)	Spare code
Code	Voltage				
L	12 VDC	108 °C	30 W	4.7 Ω	M14100010
M	24 VDC	108 °C	30 W	18.8 Ω	M14100011

(1) Ambient temperature 25 °C - (2) Ambient temperature 20 °C

CONNECTORS

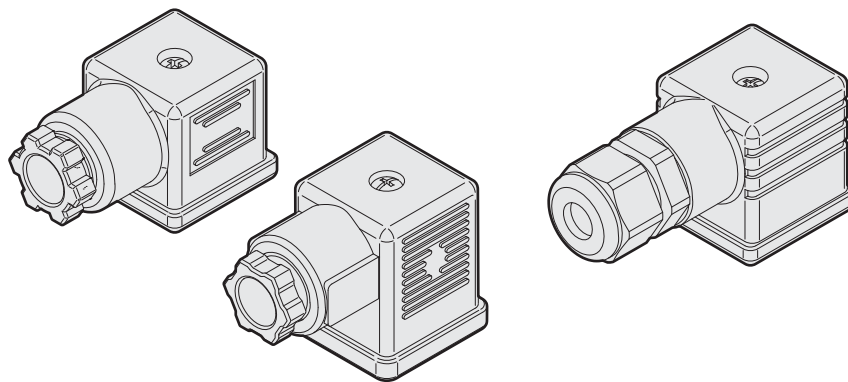

CONNECTORS FOR CONTROL VALVES IN ACCORDANCE WITH DIN 43650 / ISO 4400

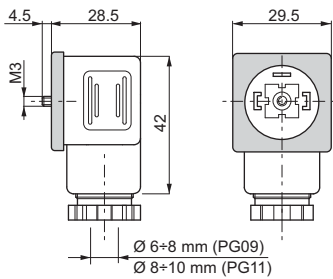

Connector	Protection level	Type	Cable gland	Code
Standard	IP65	Black color	PG09	V86 05 0002
		Grey color	PG09	V86 05 0004
		Black color	PG11	V86 05 0006
		Grey color	PG11	V86 05 0008
Lens cover with pilot light (1)	IP65	12 VAC/VDC	PG09	V86 10 0018
		24 VAC/VDC	PG09	V86 10 0012
		115 VAC/VDC	PG09	V86 10 0020
		230 VAC/VDC	PG09	V86 10 0022

(1) do not use for proportional versions

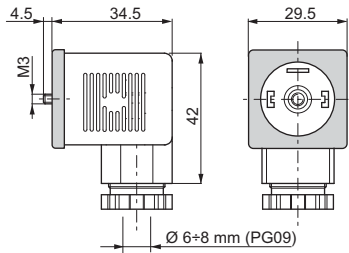

Connector	Protection level	Type	Cable gland	Code
With rectifier (1) Inlet voltage 12÷230 VAC Outlet voltage 9÷205 VDC	IP65	Black color	PG09	V86 20 0002
		Grey color	PG09	V86 20 0004
Lens cover with pilot light and rectifier (1) Inlet voltage 12÷230 VAC Outlet voltage 9÷205 VDC	IP65	12 VAC	PG09	V86 25 0018
		24 VAC	PG09	V86 25 0019
		48 VAC	PG09	V86 25 0020
		115 VAC	PG09	V86 25 0021
		230 VAC	PG09	V86 25 0022

(1) do not use for proportional versions

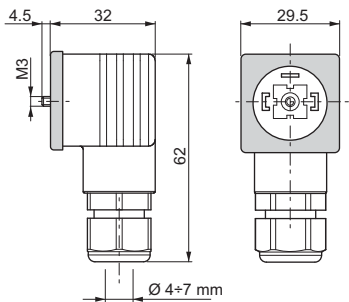

Connector	Protection level	Type	Cable gland	Code
With protection level IP67	IP67	Black color	—	V86 28 0001
		Grey color	—	V86 28 0002

Electrical features of connectors

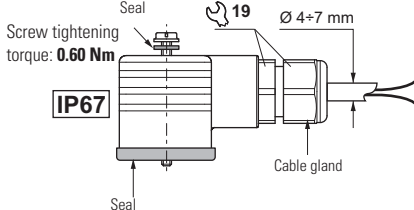
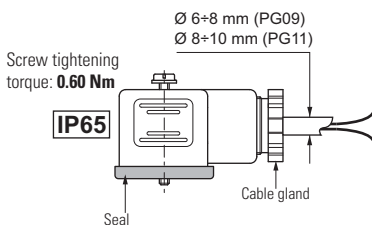

Description	IP65	IP67
AC rated voltage	Max. 250 V	Max. 250 V
DC rated voltage	Max. 300 V	Max. 300 V
Pin contact nominal current	10A	10A
Pin contact max. current	16A	16A
Max. section cable	1.5 mm ²	1.5 mm ²
Cable gland PG09 - M16x1,5	Ø cable 6 ÷ 8 mm	Ø cable 4 ÷ 7 mm
Cable gland PG11 - G 1/2" - M20x1,5	Ø cable 8 ÷ 10 mm	—
Protection level	IP65 EN60529	IP67 EN60529
Insulation class	VDE 0110-1/89	VDE 0110-1/89
Operating temperature	-40°C ÷ 90°C	-20°C ÷ 80°C

The degrees of protection indicate is guaranteed only if the connectors were properly mounted with his original seals.

Electrical circuits

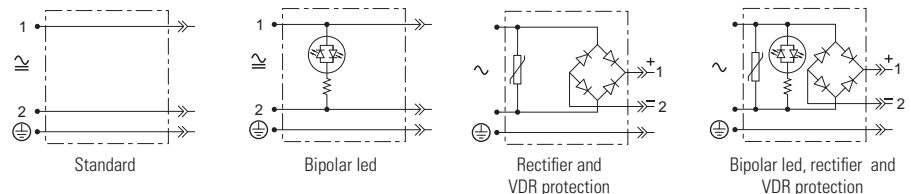

AMP JUNIOR CONNECTORS

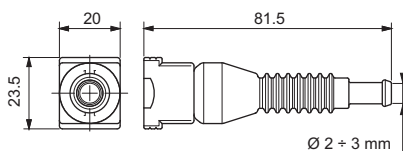

Connector	Type	Cable section	Pin contact max current	Code
AMP Junior connector Timer 2 contact	Black color	0,5 ÷ 1,5 mm ²	10A	RKRC0808000

Note

Note



BREVINI®

Motion Systems

Code DOC00044 - Rev. I2

Dana Motion Systems Italia S.r.l.

Fluid Power Division

Sede operativa: Via Giulio Natta 1, 42124 Reggio Emilia - Italy

Tel: +39.0522.270711 - Fax: +39.0522.505856

Sede legale: Via Luciano Brevini 1/A, 42124 Reggio Emilia - Italy

Tel: +39.0522.9281 - Fax: +39.0522.928300

www.dana.com/brevini - dana.re@dana.com

