

# End Power Cylinder

RoHS

Size:  $\varnothing 40$ ,  $\varnothing 50$

**Air consumption**  
**Max. 73% reduction**

3.6 L (ANR) → 2.3 L (ANR)  
 \* Compared with the CQ2 series,  $\varnothing 50$ , 200 mm stroke

**Output is generated from 5 mm in front of the stroke end.**

(Extending operation only)

- Energy saving can be achieved by using the assist cylinder to reach the output stroke position.

Output stroke (5 mm)

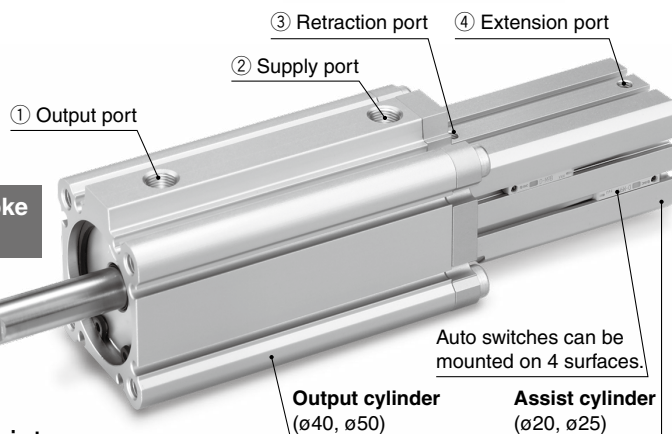

Auto switches can be mounted on 4 surfaces.

## Output working principle

### Extending operation in progress

Since the air passage ① is open while the assist cylinder is operating, the output cylinder is acting as a tank. (Air is not being consumed.)

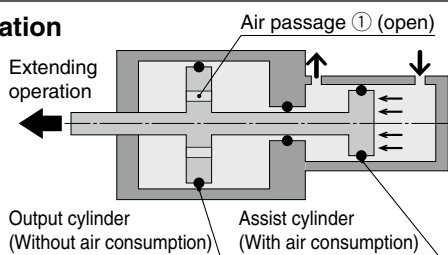

### When output is generated

When the piston of the output cylinder reaches the output stroke, the air passage ① is closed, the output port ② opens, causing a pressure differential, and cylinder output force is generated.

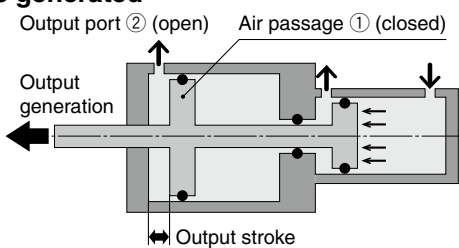

- Smooth operation even when output is generated
- The CQ2 series rod flange type is mountable
- Controllable by a single solenoid valve in the same way as a conventional cylinder

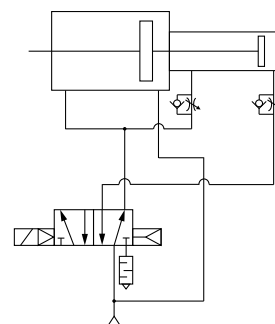

## Output that instantaneously rises

Set output reached in 0.1 s

### Output wave form

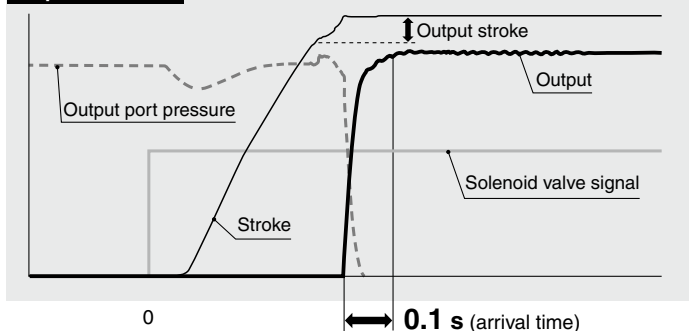

## Application Example

Optimal for applications such as press fitting and clamping that require force at the stroke end

Press fitting force is generated at the output stroke.

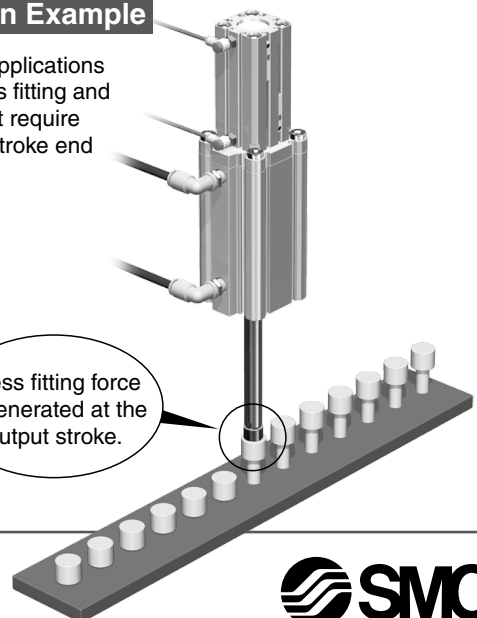

**CDQ2A-X3260**



20-E755

# CDQ2A-X3260

## How to Order

**C D Q2 A 40 - 100 D C Z - M9BW - X3260**

**With auto switch**  
(Built-in magnet)

**Mounting**

<b>A</b>	Rod end tapped
<b>F</b>	Rod flange

\* The mounting bracket is shipped together with the product but does not come assembled.

**Bore size**

<b>40</b>	40 mm x 20 mm
<b>50</b>	50 mm x 25 mm

**With rubber bumper**  
(Head end only)

**Cylinder stroke**

Bore size	Standard stroke [mm]
<b>40, 50</b>	50, 100, 150, 200

**End power type**

**Number of auto switches**

<b>Nil</b>	2
<b>S</b>	1
<b>n</b>	n

**Auto switch**

<b>Nil</b>	Without auto switch
------------	---------------------

\* Auto switch models are the same as those for the CQS series compact cylinder. For details, refer to the [Web Catalog](#).

## Specifications

Bore size [mm]	Output cylinder	40	50
		Assist cylinder	20
<b>Action</b>		Double acting, Single rod	
<b>Fluid</b>		Air	
<b>Proof pressure</b>		1.0 MPa	
<b>Max. operating pressure</b>		0.7 MPa	
<b>Min. operating pressure*1</b>		0.2 MPa	
<b>Ambient and fluid temperatures</b>		-10°C to 60°C (No freezing)	
<b>Lubrication</b>		Not required (Non-lube)	
<b>Piston speed</b>		50 to 300 mm/s	
<b>Stroke</b>		50, 100, 150, 200	
<b>Stroke length tolerance*2</b>		0 to +1.4 mm	
<b>Cushion</b>		Rubber bumper (Head end only)	
<b>Port size</b>	<b>Output cylinder</b>	Rc1/8	
	<b>Assist cylinder</b>	M5	
<b>Allowable kinetic energy</b>		0.09 J	0.15 J
<b>Mounting</b>		Tap mounting type (Rod end only)	
<b>Mounting bracket</b>		Rod flange	
<b>Output stroke</b>		5 mm (Extending operation only)	

\*1 Refer to "Handling 6."

\*2 The stroke length tolerance does not include the amount of bumper change.

## Theoretical Output

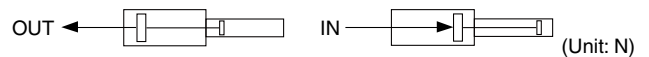

Size	Bore size [mm]		Operating direction	Operating pressure [MPa]			
	Output cylinder	Assist cylinder		0.3	0.5	0.7	
40	40	20	IN	66	107	147	
			OUT	Assist stroke	94	157	220
				Output stroke*1	425	723	1,021
50	50	25	IN	107	174	242	
			OUT	Assist stroke	147	245	344
				Output stroke*1	679	1,148	1,616

\*1 Output stroke: output is only generated 5 mm in front of the stroke end.

## Dimensions

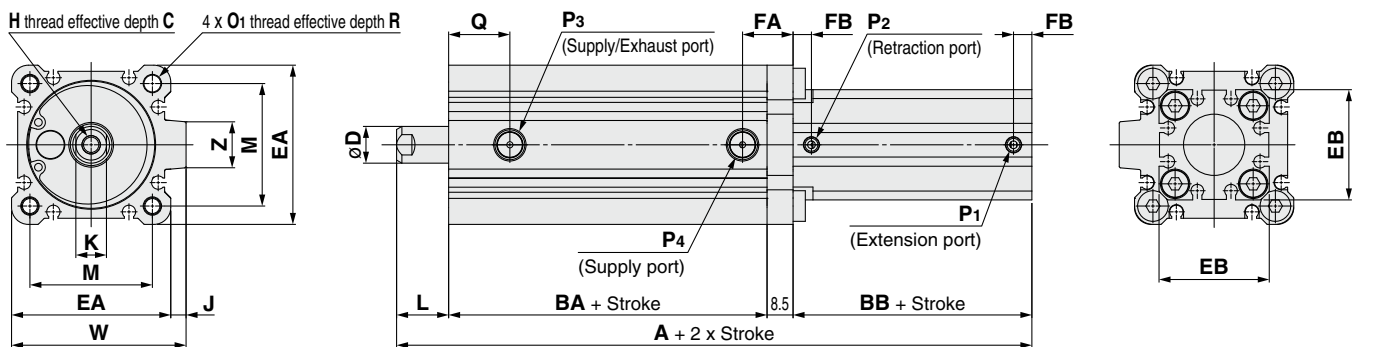

Bore size	A	BA	BB	C	D	EA	EB	FA	FB	H	J	K	L	M	P1	P2	P3	P4	O1	R	W	Z
40	97.5	54	28	12	12	52	36	16.5	6	M6 x 1	5	10	17	40	M5 x 0.8	M5 x 0.8	Rc1/8	Rc1/8	M6 x 1	10	57	15
50	96.5	49	31	13	14	64	40	16.5	6	M8 x 1.25	7	12	18	50	M5 x 0.8	M5 x 0.8	Rc1/8	Rc1/8	M8 x 1.25	14	71	19

## Handling

### ⚠ Caution

1. When installing or removing load, be sure to secure the piston rod width across flats part with the piston rod in a fully retracted state.

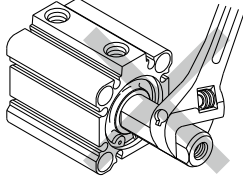

2. Avoid using the air cylinder in such a way that rotational torque would be applied to the piston rod. Failure to do so may result in the loosening of the joint screw part inside the cylinder, leading to unexpected failure.

Use the table below as a guide for the allowable rotational torque ranges.

Allowable rotational torque	40	50
N·m or less	0.2	0.25

Operate the cylinder so that the load to the piston rod is always applied in the axial direction.

3. Pipe according to the circuit diagram shown below when using this cylinder.

#### Circuit diagram

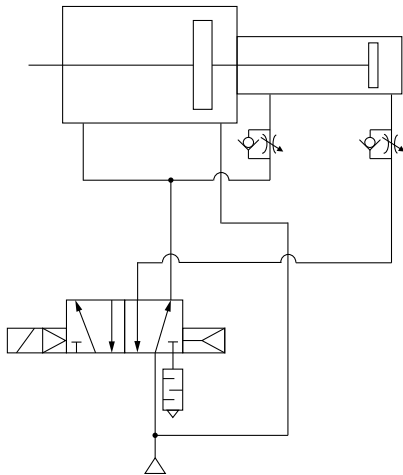

4. Supply the same amount of air pressure to both the assist cylinder and the supply port at all times. If the supply pressure differs, a malfunction may result.
5. Be aware that the cylinder's retraction output is the retraction output of the assist cylinder.
6. When using at the min. operating pressure, if the stopping time is increased, a sticking phenomenon may occur when restarting, preventing operation. If this happens, raise the supply pressure and perform several pre-conditioning interim operation cycles to solve the problem. Be aware of how to perform this operation beforehand.
7. When the cylinder's operating speed is to be controlled, a speed controller should be installed at the top of the assist cylinder's piping.
8. When mounting an auto switch, attach it to the assist cylinder.

**⚠ Safety Instructions** Be sure to read the "Handling Precautions for SMC Products" (M-E03-3) and the "CQ2 Series Specific Product Precautions" before use.

## SMC Corporation

Akihabara UDX 15F,  
4-14-1, Sotokanda, Chiyoda-ku, Tokyo 101-0021, JAPAN  
Phone: 03-5207-8249 Fax: 03-5298-5362  
<https://www.smcworld.com>  
© 2020 SMC Corporation All Rights Reserved

Specifications are subject to change without prior notice and any obligation on the part of the manufacturer.