

NAAMS Standards Compliant Power Clamp Cylinder

CKZ2N Series

ø50, ø63, ø80

High clamping force

Clamping force: **8800 N**

(ø80, Arm length: 100 mm, 0.5 MPa pressure)

Force amplification with a toggle mechanism and lock function

Can hold a clamped state when supply pressure drops or residual pressure is released

Spatter-proof construction

Fully closed structure prevents the intrusion of spatter

Equipped with a proximity switch that can be used in welding magnetic fields



Power Clamp Cylinders

CKZM16
CKZT25/32
CKZT40
CKZ3T
CKZT80
CKZ3N
CKZ2N

Related Products

C(L)KQG□
C(L)KQP□
C(L)KQ□D
-X3256
C(L)KQG32
C(L)KU32
C(L)KQG32
-X3036
Flow Control Equipment
Piping Equipment

NAAMS Standards Compliant Power Clamp Cylinder

CKZ2N Series

ø50, ø63, ø80



How to Order

Base type

CKZ2N 63 TF - 120 R T

NAAMS Standards compliant
power clamp cylinder

Bore size

50	50 mm equivalent
63	63 mm equivalent
80	80 mm equivalent

Cylinder port

Nil	NPT
TF	G

Arm opening angle

30	30°
45	45°
60	60°
75	75°
90	90°
105	105°
120	120°
135	135°

Proximity switch

T	TURCK
P	P&F

Clamp arm position

R	L	D
Right	Left	Both sides

* Proximity switch mounting
surface viewed from the front

Clamp arm

CKZ - 63 A002

Bore size

50	50 mm equivalent
63	63 mm equivalent
80	80 mm equivalent

Clamp arm code
(Refer to pages 91 to 99.)

Cylinder Specifications

Bore size [mm]	50	63	80
Action	Double acting		
Fluid	Air		
Proof pressure	1.2 MPa		
Max. operating pressure	0.8 MPa		
Min. operating pressure	0.3 MPa		
Ambient and fluid temperatures	-10 to 60°C		
Cushion	Clamping side: None Unclamping side: Rubber bumper		
Operating time	Clamping: 1 sec. or more, Unclamping: 1 sec. or more		
Max. allowable holding moment*1	800 N·m	1500 N·m	2500 N·m

*1 Refers to the maximum holding force (torque) while clamped with the operating air exhausted
This is not the possible holding force (torque) for normal use.

Weight (Cylinder Without Arm)

Bore size [mm]	Arm position	Arm opening angle							
		30°	45°	60°	75°	90°	105°	120°	135°
50	R/L	5.2	5.2	5.2	5.2	5.1	5.1	5.1	5.1
	D	5.3	5.3	5.2	5.2	5.2	5.2	5.1	5.1
63	R/L	7.4	7.3	7.3	7.3	7.2	7.2	7.2	7.2
	D	7.5	7.4	7.4	7.4	7.3	7.3	7.3	7.3
80	R/L	17.2	17.1	17.1	17.0	16.9	16.9	16.8	16.8
	D	17.4	17.4	17.3	17.2	17.2	17.1	17.0	17.0

Cylinder Stroke

Bore size	Angle	30°	45°	60°	75°	90°	105°	120°	135°
		50	31.1	38.9	46.4	54.1	61.9	69.6	76.4
63	34.1	42.5	50.5	58.6	66.8	74.7	81.5	86.3	
80	47.3	59.4	71.1	83.2	95.7	108.0	119.1	127.3	

Proximity Switch Specifications

Manufacturer	TURCK	P&F
Power supply voltage	10 to 30 VDC	10 to 30 VDC
Output	N.O., PNP	N.O., PNP
Continuous load current	150 mA	100 mA
Response frequency	30 Hz	25 Hz
Housing material	PBT	PA6, PBT
Output indication	Clamping side: Red Unclamping side: Yellow	Clamping side: Red Unclamping side: Yellow
Power supply indication	Green	Green
Connector	M12 connector	M12 connector

* Switch specifications correspond to the manufacturers' technical information.

Wiring Diagram (PNP Connection Circuit)

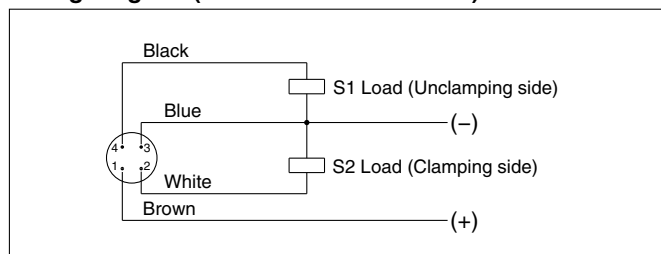

* Applicable to both TURCK and P&F
* Please contact SMC for NPN specifications.

Power Clamp Cylinders
CKZM16
CKZT25/32
CKZT40
CKZ3T
CKZT80
CKZ3N
CKZ2N
Related Products
C(L)KQG□
C(L)KQP□
C(L)KQ□D
-X3256
C(L)KQG32
C(L)KU32
C(L)KQG32
-X3036
Flow Control Equipment
Piping Equipment

CKZ2N Series

Replacement Parts

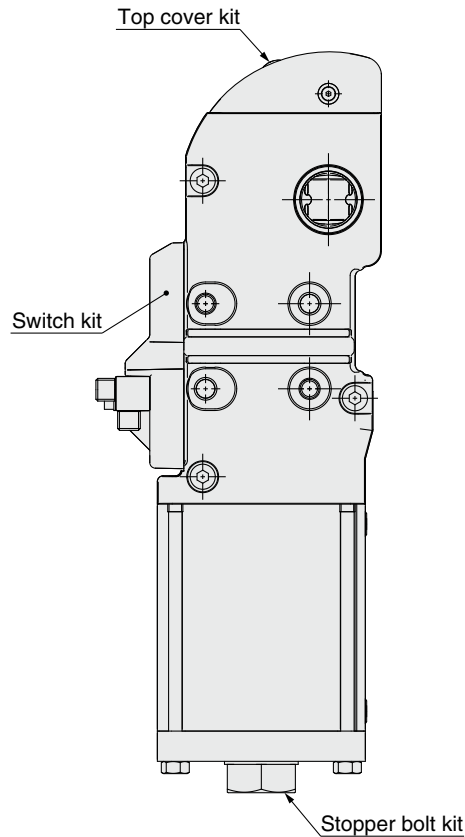

Switch Kit No.

CKZ1N-S **050** **T**

• **Bore size**

050	ø50 equivalent
063	ø63 equivalent
080	ø80 equivalent

• **Proximity switch**

T	TURCK
P	P&F

* The switch kit includes a switch holder, proximity switch, and mounting brackets.

Top Cover Kit No.

Rubber cover

CKZ2N-T **050**

• **Bore size**

050	ø50 equivalent
063	ø63 equivalent
080	ø80 equivalent

* The top cover kit includes a top cover and mounting brackets.

* Refer to page 104 for the procedure for changing the arm opening angle and top cover replacement instructions.

Kit No. for Changing the Arm Opening Angle

CKZN-B **050** **D**

• **Kit type**

B	Stopper bolt kit
D	Dog kit
K	A set of B and D

• **Bore size**

050	ø50 equivalent
063	ø63 equivalent
080	ø80 equivalent

• **Arm opening angle**

H	30°
G	45°
F	60°
E	75°
D	90°
C	105°
B	120°
A	135°

* The stopper bolt kit includes a stopper bolt and mounting brackets.

* The dog kit includes a dog and mounting brackets.

Dimensions

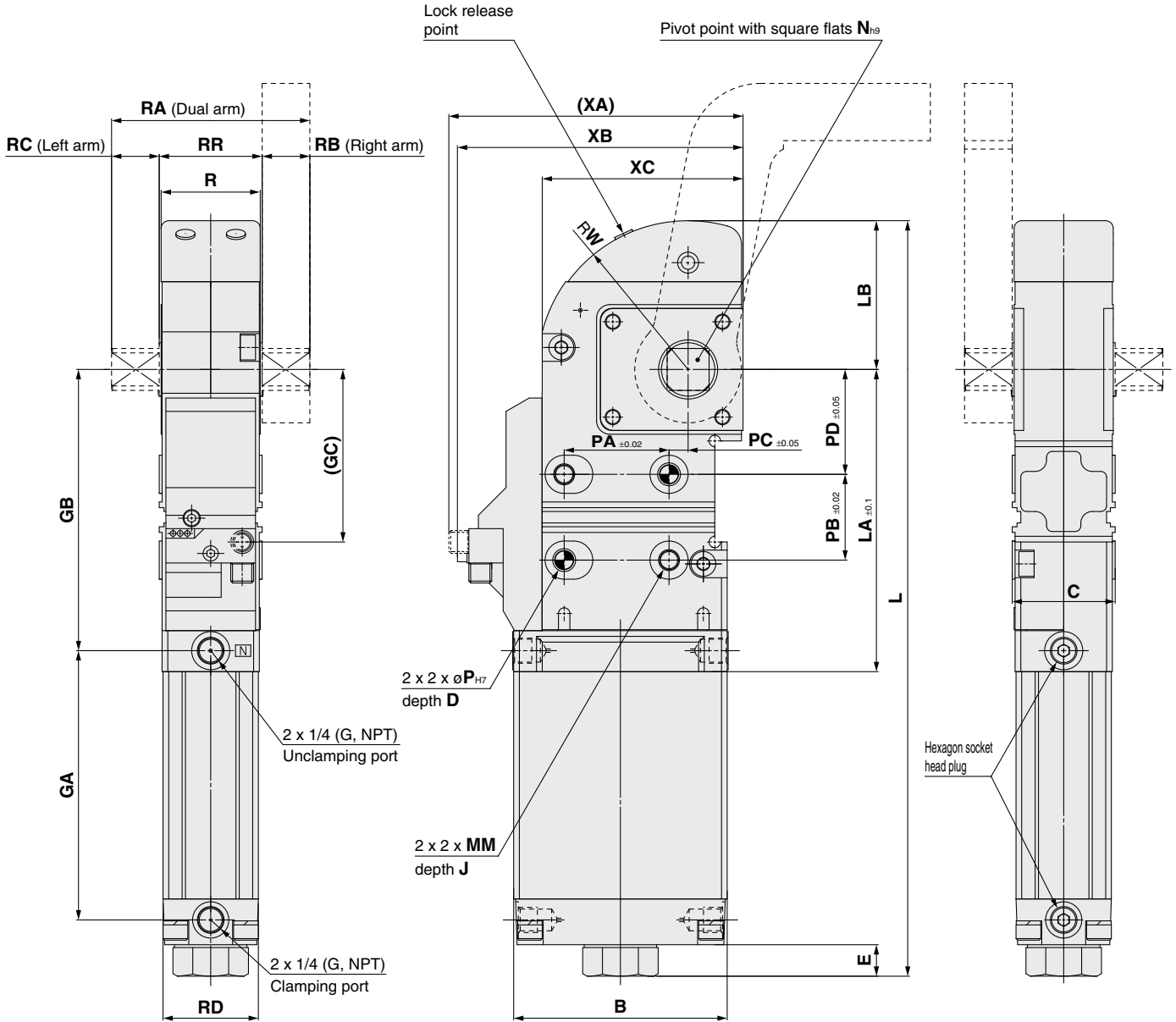

Bore size [mm]	B	C	D	E	GA	GB	GC	J	L	LA	LB	MM	N	P
50	95	48	12	13.7	134.3	138.5	93	12	376.7	149.5	78.4	M8 x 1.25	19	8
63	112	54	15	16.6	141.2	147.5	90.5	12	395.6	158.5	78	M10 x 1.5	22	10
80	154	76	12	19.6	185.8	199	137.5	18	530.9	214	113.7	M12 x 1.75	30	12

Bore size [mm]	PA	PB	PC	PD	R	RA	RB	RC	RD	RR	W	XA	XB	XC
50	45	45	5	40	45	88	20	20	45	48	78.4	141.8	137.3	92.8
63	55	45	10	55	52	104	25	25	50	54	78	154.4	150.4	105.3
80	70	75	15	65	70	140	32	32	68	76	113.7	197.3	192.8	148.3

- Power Clamp Cylinders
- CKZM16
 - CKZT25/32
 - CKZT40
 - CKZ3T
 - CKZT80
 - CKZ3N
 - CKZ2N**
- Related Products
- C(L)KQG□
 - C(L)KQP□
 - C(L)KQ□D
 - X3256
 - C(L)KQG32
 - C(L)KU32
 - C(L)KQG32
 - X3036
- Flow Control Equipment
- Piping Equipment

CKZ2N Series

Clamp Arm Code List

Bore size	SMC part no.	Code	NAAMS Ref. no.
50	CKZ-50A001	A001	ACA201M
	CKZ-50A002	A002	ACA202M
	CKZ-50A003	A003	ACA203M
	CKZ-50A004	A004	ACA206M
	CKZ-50A005	A005	ACA207M
	CKZ-50A006	A006	ACA208M
	CKZ-50A007	A007	ACA211M
	CKZ-50A008	A008	ACA212M
	CKZ-50A009	A009	ACA213M
	CKZ-50A010	A010	ACA216M
	CKZ-50A011	A011	ACA217M
	CKZ-50A012	A012	ACA218M
	CKZ-50A013	A013	ACA221M
	CKZ-50A014	A014	ACA222M
	CKZ-50A015	A015	ACA223M
	CKZ-50A016	A016	ACA226M
	CKZ-50A017	A017	ACA227M
	CKZ-50A018	A018	ACA228M
	CKZ-50A019	A019	ACA236M
	CKZ-50A020	A020	ACA237M
	CKZ-50A021	A021	ACA238M
	CKZ-50A022	A022	ACA246M
	CKZ-50A023	A023	ACA247M
	CKZ-50A024	A024	ACA248M
	CKZ-50A025	A025	ACA256M
	CKZ-50A026	A026	ACA257M
	CKZ-50A027	A027	ACA258M
63	CKZ-63A001	A001	ACA001M
	CKZ-63A002	A002	ACA002M
	CKZ-63A003	A003	ACA003M
	CKZ-63A004	A004	ACA004M
	CKZ-63A005	A005	ACA005M
	CKZ-63A006	A006	ACA006M
	CKZ-63A007	A007	ACA007M
	CKZ-63A008	A008	ACA008M
	CKZ-63A009	A009	ACA009M
	CKZ-63A010	A010	ACA010M
	CKZ-63A011	A011	ACA011M

Bore size	SMC part no.	Code	NAAMS Ref. no.
63	CKZ-63A012	A012	ACA012M
	CKZ-63A013	A013	ACA013M
	CKZ-63A014	A014	ACA014M
	CKZ-63A015	A015	ACA015M
	CKZ-63A016	A016	ACA016M
	CKZ-63A017	A017	ACA017M
	CKZ-63A018	A018	ACA018M
	CKZ-63A019	A019	ACA019M
	CKZ-63A020	A020	ACA020M
	CKZ-63A021	A021	ACA021M
	CKZ-63A022	A022	ACA022M
	CKZ-63A023	A023	ACA023M
	CKZ-63A024	A024	ACA024M
	CKZ-63A025	A025	ACA025M
	CKZ-63A026	A026	ACA026M
	CKZ-63A027	A027	ACA027M
	CKZ-63A028	A028	ACA028M
	CKZ-63A029	A029	ACA029M
	CKZ-63A030	A030	ACA030M
	CKZ-63A031	A031	ACA031M
	CKZ-63A032	A032	ACA032M
	CKZ-63A033	A033	ACA033M
	CKZ-63A034	A034	ACA034M
	CKZ-63A035	A035	ACA035M
	CKZ-63A036	A036	ACA036M
	CKZ-63A037	A037	ACA037M
	CKZ-63A038	A038	ACA038M
	CKZ-63A039	A039	ACA039M
	CKZ-63A040	A040	ACA040M
	CKZ-63A041	A041	ACA041M
	CKZ-63A042	A042	ACA042M
	CKZ-63A043	A043	ACA043M
	CKZ-63A044	A044	ACA044M
	CKZ-63A045	A045	ACA045M
	CKZ-63A046	A046	ACA046M
	CKZ-63A047	A047	ACA047M
	CKZ-63A048	A048	ACA048M

Bore size	SMC part no.	Code	NAAMS Ref. no.
80	CKZ-80A001	A001	ACA100M
	CKZ-80A002	A002	ACA101M
	CKZ-80A003	A003	ACA102M
	CKZ-80A004	A004	ACA103M
	CKZ-80A005	A005	ACA104M
	CKZ-80A006	A006	ACA105M
	CKZ-80A007	A007	ACA106M
	CKZ-80A008	A008	ACA107M
	CKZ-80A009	A009	ACA108M
	CKZ-80A010	A010	ACA110M
	CKZ-80A011	A011	ACA111M
	CKZ-80A012	A012	ACA112M
	CKZ-80A013	A013	ACA113M
	CKZ-80A014	A014	ACA114M
	CKZ-80A015	A015	ACA115M
	CKZ-80A016	A016	ACA116M
	CKZ-80A017	A017	ACA117M
	CKZ-80A018	A018	ACA118M
	CKZ-80A019	A019	ACA120M
	CKZ-80A020	A020	ACA121M
	CKZ-80A021	A021	ACA122M
	CKZ-80A022	A022	ACA123M
	CKZ-80A023	A023	ACA124M
	CKZ-80A024	A024	ACA125M
	CKZ-80A025	A025	ACA126M
	CKZ-80A026	A026	ACA127M
	CKZ-80A027	A027	ACA128M
	CKZ-80A028	A028	ACA130M
	CKZ-80A029	A029	ACA131M
	CKZ-80A030	A030	ACA132M
	CKZ-80A031	A031	ACA133M
	CKZ-80A032	A032	ACA134M
	CKZ-80A033	A033	ACA135M
	CKZ-80A034	A034	ACA136M
	CKZ-80A035	A035	ACA137M
	CKZ-80A036	A036	ACA138M
	CKZ-80A037	A037	ACA140M

Bore size	SMC part no.	Code	NAAMS Ref. no.
80	CKZ-80A038	A038	ACA141M
	CKZ-80A039	A039	ACA142M
	CKZ-80A040	A040	ACA143M
	CKZ-80A041	A041	ACA144M
	CKZ-80A042	A042	ACA145M
	CKZ-80A043	A043	ACA146M
	CKZ-80A044	A044	ACA147M
	CKZ-80A045	A045	ACA148M
	CKZ-80A046	A046	ACA150M
	CKZ-80A047	A047	ACA151M
	CKZ-80A048	A048	ACA152M
	CKZ-80A049	A049	ACA153M
	CKZ-80A050	A050	ACA154M
	CKZ-80A051	A051	ACA155M
	CKZ-80A052	A052	ACA156M
	CKZ-80A053	A053	ACA157M
	CKZ-80A054	A054	ACA158M
	CKZ-80A055	A055	ACA160M
	CKZ-80A056	A056	ACA161M
	CKZ-80A057	A057	ACA162M
	CKZ-80A058	A058	ACA163M
	CKZ-80A059	A059	ACA164M
	CKZ-80A060	A060	ACA165M
	CKZ-80A061	A061	ACA166M
	CKZ-80A062	A062	ACA167M
	CKZ-80A063	A063	ACA168M
	CKZ-80A064	A064	ACA170M
	CKZ-80A065	A065	ACA171M
	CKZ-80A066	A066	ACA172M
	CKZ-80A067	A067	ACA173M
	CKZ-80A068	A068	ACA174M
	CKZ-80A069	A069	ACA175M
	CKZ-80A070	A070	ACA176M
	CKZ-80A071	A071	ACA177M
	CKZ-80A072	A072	ACA178M

Dimensions: Clamp Arm Bore Size 50

Straight: Plain

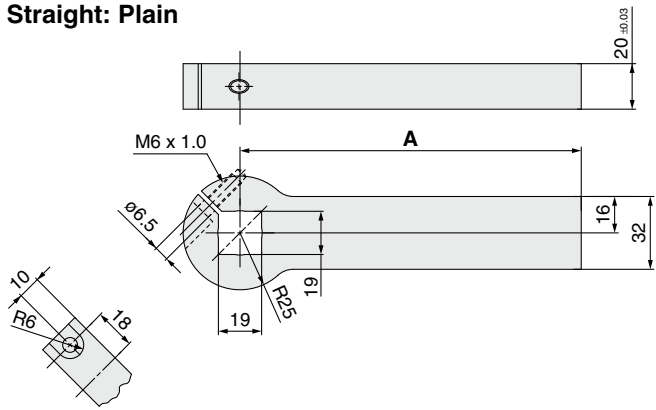

Part no.	NAAMS code	A	Weight [kg]
CKZ-50A001	ACA201M	90.0	0.6
CKZ-50A002	ACA202M	120.0	0.7
CKZ-50A003	ACA203M	150.0	0.9

20 mm offset: Plain

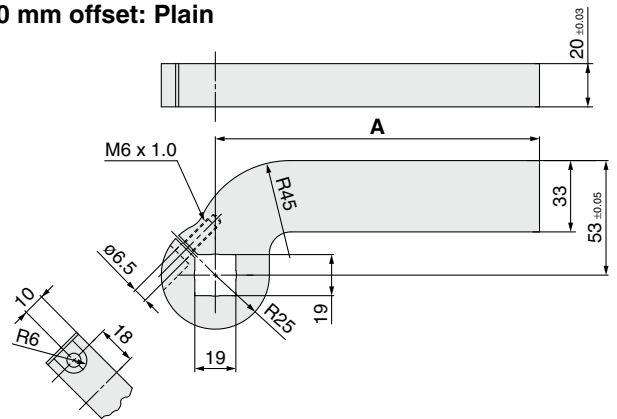

Part no.	NAAMS code	A	Weight [kg]
CKZ-50A007	ACA211M	90.0	0.7
CKZ-50A008	ACA212M	120.0	0.8
CKZ-50A009	ACA213M	150.0	1.0

Straight: Machined

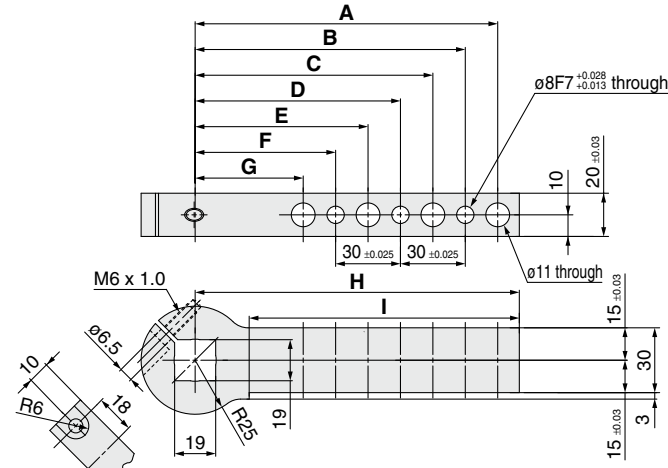

Part no.	NAAMS code	A	B	C	D	E	F	G	H	I	Weight [kg]
CKZ-50A004	ACA206M	80.0	65.0	50.0	—	—	—	—	90.0	65.0	0.5
CKZ-50A005	ACA207M	110.0	95.0	80.0	65.0	50.0	—	—	120.0	95.0	0.6
CKZ-50A006	ACA208M	140.0	125.0	110.0	95.0	80.0	65.0	50.0	150.0	125.0	0.7

25 mm offset: Machined

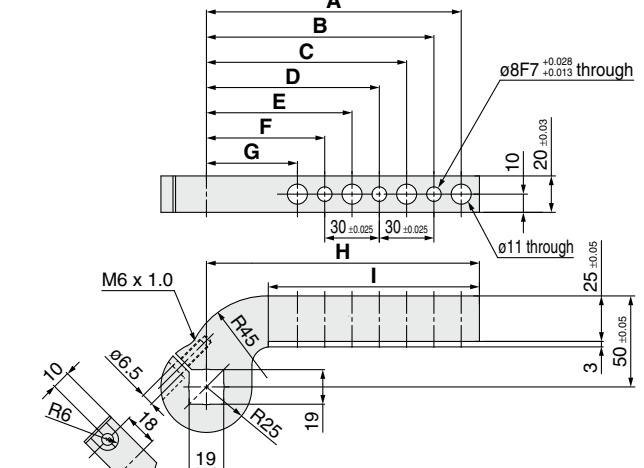

Part no.	NAAMS code	A	B	C	D	E	F	G	H	I	Weight [kg]
CKZ-50A010	ACA216M	80.0	65.0	50.0	—	—	—	—	90.0	56.0	0.5
CKZ-50A011	ACA217M	110.0	95.0	80.0	65.0	50.0	—	—	120.0	86.0	0.6
CKZ-50A012	ACA218M	140.0	125.0	110.0	95.0	80.0	65.0	50.0	150.0	116.0	0.7

Straight: Machined

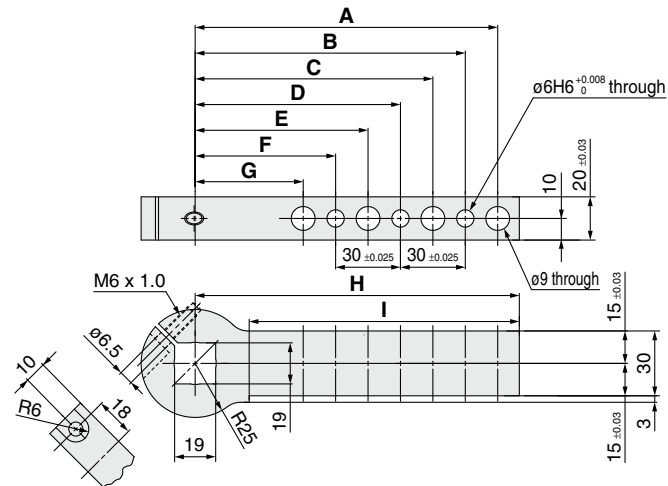

Part no.	NAAMS code	A	B	C	D	E	F	G	H	I	Weight [kg]
CKZ-50A019	ACA236M	80.0	65.0	50.0	—	—	—	—	90.0	65.0	0.5
CKZ-50A020	ACA237M	110.0	95.0	80.0	65.0	50.0	—	—	120.0	95.0	0.6
CKZ-50A021	ACA238M	140.0	125.0	110.0	95.0	80.0	65.0	50.0	150.0	125.0	0.7

25 mm offset: Machined

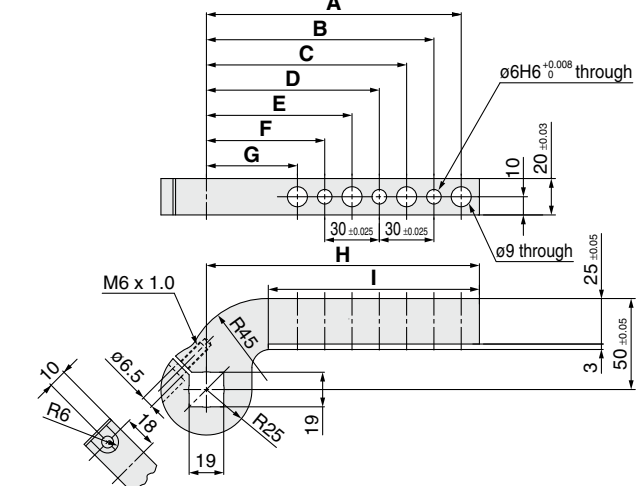

Part no.	NAAMS code	A	B	C	D	E	F	G	H	I	Weight [kg]
CKZ-50A022	ACA246M	80.0	65.0	50.0	—	—	—	—	90.0	56.0	0.5
CKZ-50A023	ACA247M	110.0	95.0	80.0	65.0	50.0	—	—	120.0	86.0	0.6
CKZ-50A024	ACA248M	140.0	125.0	110.0	95.0	80.0	65.0	50.0	150.0	116.0	0.7

- Power Clamp Cylinders
- CKZM16
 - CKZT25/32
 - CKZT40
 - CKZ3T
 - CKZT80
 - CKZ3N
 - CKZ2N

- Related Products
- C(L)KQG□
 - C(L)KQP□
 - C(L)KQ□D
 - X3256
 - C(L)KQG32
 - C(L)KU32
 - C(L)KQG32
 - X3036
 - Flow Control Equipment
 - Piping Equipment

CKZ2N Series

Dimensions: Clamp Arm **Bore Size 50**

45 mm offset: Plain

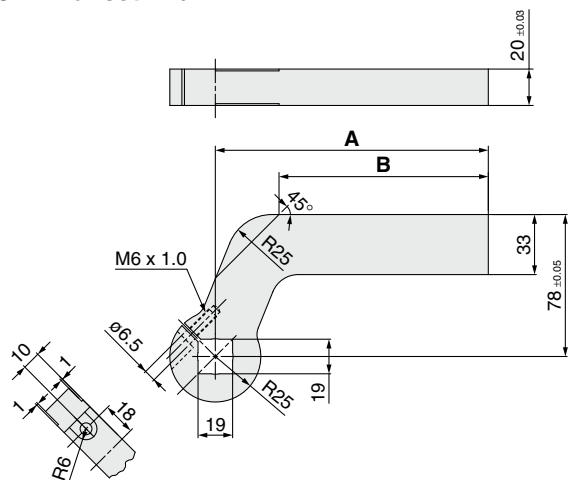

Part no.	NAAMS code	A	B	Weight [kg]
CKZ-50A013	ACA221M	90.0	55.0	0.8
CKZ-50A014	ACA222M	120.0	85.0	0.9
CKZ-50A015	ACA223M	150.0	115.0	1.1

50 mm offset: Machined

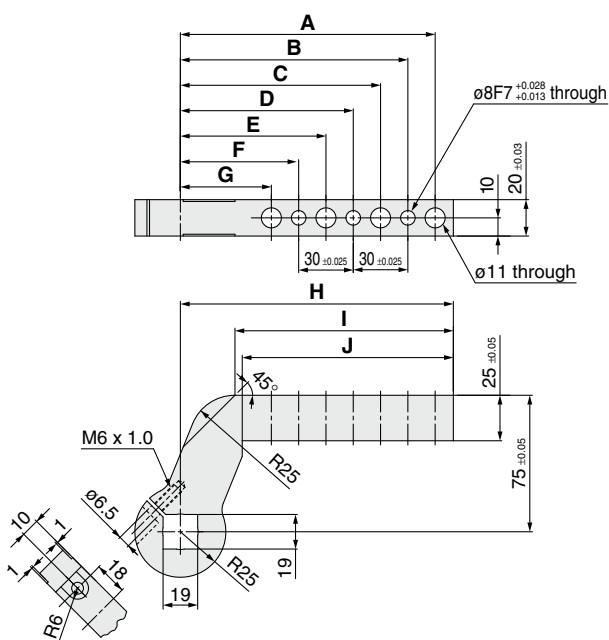

Part no.	NAAMS code	A	B	C	D	E	F	G	H	I	J	Weight [kg]
CKZ-50A016	ACA226M	80.0	65.0	50.0	—	—	—	—	90.0	60.0	56.0	0.6
CKZ-50A017	ACA227M	110.0	95.0	80.0	65.0	50.0	—	—	120.0	90.0	86.0	0.7
CKZ-50A018	ACA228M	140.0	125.0	110.0	95.0	80.0	65.0	50.0	150.0	120.0	116.0	0.8

50 mm offset: Machined

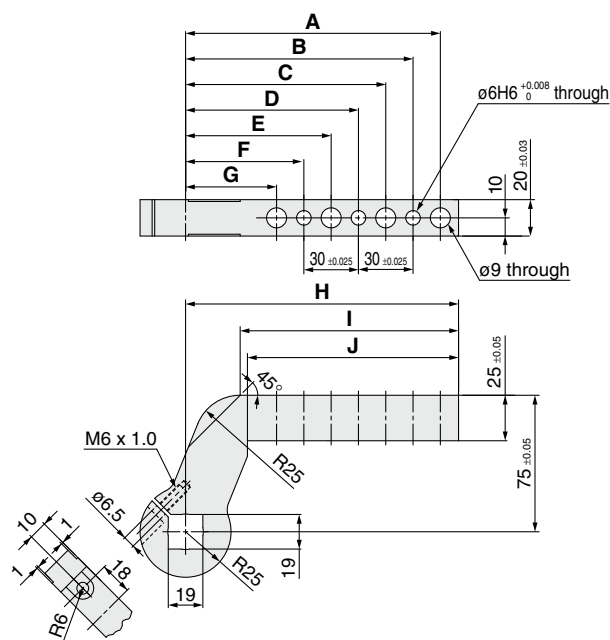

Part no.	NAAMS code	A	B	C	D	E	F	G	H	I	J	Weight [kg]
CKZ-50A025	ACA256M	80.0	65.0	50.0	—	—	—	—	90.0	60.0	56.0	0.6
CKZ-50A026	ACA257M	110.0	95.0	80.0	65.0	50.0	—	—	120.0	90.0	86.0	0.7
CKZ-50A027	ACA258M	140.0	125.0	110.0	95.0	80.0	65.0	50.0	150.0	120.0	116.0	0.8

Dimensions: Clamp Arm Bore Size 63

Straight: Plain

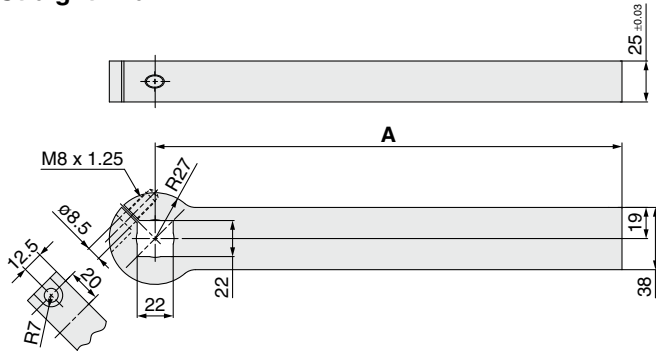

Part no.	NAAMS code	A	Weight [kg]
CKZ-63A001	ACA001M	135.0	1.2
CKZ-63A002	ACA002M	165.0	1.4
CKZ-63A003	ACA003M	195.0	1.6
CKZ-63A004	ACA004M	225.0	1.8
CKZ-63A005	ACA005M	255.0	2.1
CKZ-63A006	ACA006M	285.0	2.3

20 mm offset: Plain

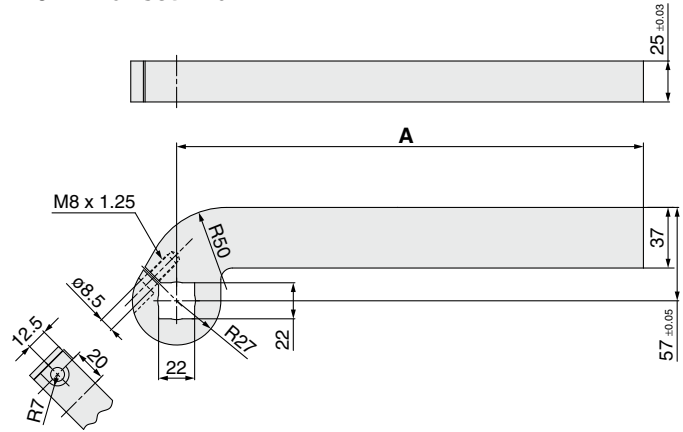

Part no.	NAAMS code	A	Weight [kg]
CKZ-63A013	ACA013M	135.0	1.4
CKZ-63A014	ACA014M	165.0	1.6
CKZ-63A015	ACA015M	195.0	1.8
CKZ-63A016	ACA016M	225.0	2.0
CKZ-63A017	ACA017M	255.0	2.2
CKZ-63A018	ACA018M	285.0	2.4

Straight: Machined

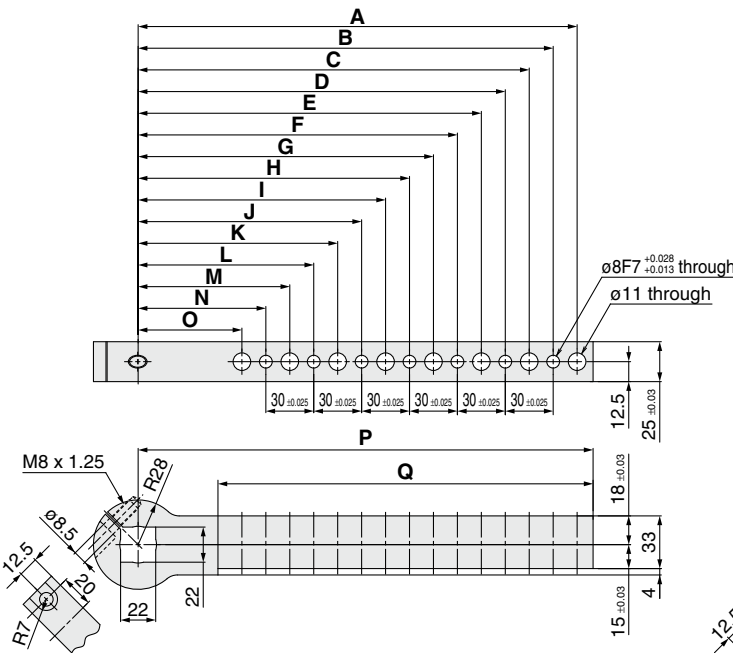

Part no.	NAAMS code	A	B	C	D	E	F	G	H	I
CKZ-63A007	ACA007M	125.0	110.0	95.0	80.0	65.0	—	—	—	—
CKZ-63A008	ACA008M	155.0	140.0	125.0	110.0	95.0	80.0	65.0	—	—
CKZ-63A009	ACA009M	185.0	170.0	155.0	140.0	125.0	110.0	95.0	80.0	65.0
CKZ-63A010	ACA010M	215.0	200.0	185.0	170.0	155.0	140.0	125.0	110.0	95.0
CKZ-63A011	ACA011M	245.0	230.0	215.0	200.0	185.0	170.0	155.0	140.0	125.0
CKZ-63A012	ACA012M	275.0	260.0	245.0	230.0	215.0	200.0	185.0	170.0	155.0

Part no.	NAAMS code	J	K	L	M	N	O	P	Q	Weight [kg]
CKZ-63A007	ACA007M	—	—	—	—	—	—	135.0	85.0	1.0
CKZ-63A008	ACA008M	—	—	—	—	—	—	165.0	115.0	1.2
CKZ-63A009	ACA009M	—	—	—	—	—	—	195.0	145.0	1.4
CKZ-63A010	ACA010M	80.0	65.0	—	—	—	—	225.0	175.0	1.5
CKZ-63A011	ACA011M	110.0	95.0	80.0	65.0	—	—	255.0	205.0	1.7
CKZ-63A012	ACA012M	140.0	125.0	110.0	95.0	80.0	65.0	285.0	235.0	1.9

25 mm offset: Machined

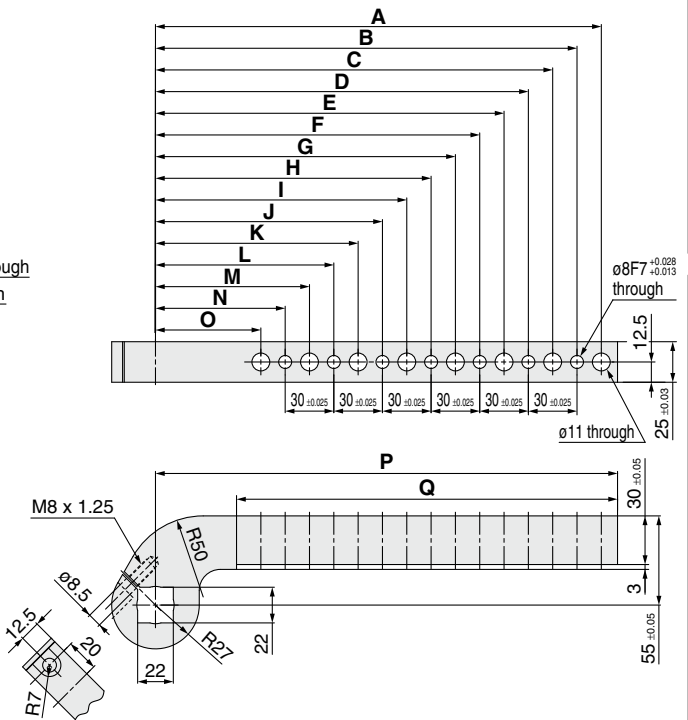

Part no.	NAAMS code	A	B	C	D	E	F	G	H	I
CKZ-63A019	ACA019M	125.0	110.0	95.0	80.0	65.0	—	—	—	—
CKZ-63A020	ACA020M	155.0	140.0	125.0	110.0	95.0	80.0	65.0	—	—
CKZ-63A021	ACA021M	185.0	170.0	155.0	140.0	125.0	110.0	95.0	80.0	65.0
CKZ-63A022	ACA022M	215.0	200.0	185.0	170.0	155.0	140.0	125.0	110.0	95.0
CKZ-63A023	ACA023M	245.0	230.0	215.0	200.0	185.0	170.0	155.0	140.0	125.0
CKZ-63A024	ACA024M	275.0	260.0	245.0	230.0	215.0	200.0	185.0	170.0	155.0

Part no.	NAAMS code	J	K	L	M	N	O	P	Q	Weight [kg]
CKZ-63A019	ACA019M	—	—	—	—	—	—	135.0	85.0	1.3
CKZ-63A020	ACA020M	—	—	—	—	—	—	165.0	115.0	1.5
CKZ-63A021	ACA021M	—	—	—	—	—	—	195.0	145.0	1.6
CKZ-63A022	ACA022M	80.0	65.0	—	—	—	—	225.0	175.0	1.7
CKZ-63A023	ACA023M	110.0	95.0	80.0	65.0	—	—	255.0	205.0	1.9
CKZ-63A024	ACA024M	140.0	125.0	110.0	95.0	80.0	65.0	285.0	235.0	2.1

- CKZM16
- CKZT25/32
- CKZT40
- CKZ3T
- CKZT80
- CKZ3N
- CKZ2N
- C(L)KQG□
- C(L)KQP□
- C(L)KQ□D
- X3256
- C(L)KQG32
- C(L)KU32
- C(L)KQG32
- X3036
- Flow Control Equipment
- Piping Equipment

CKZ2N Series

Dimensions: Clamp Arm **Bore Size 63**

65 mm offset: Plain

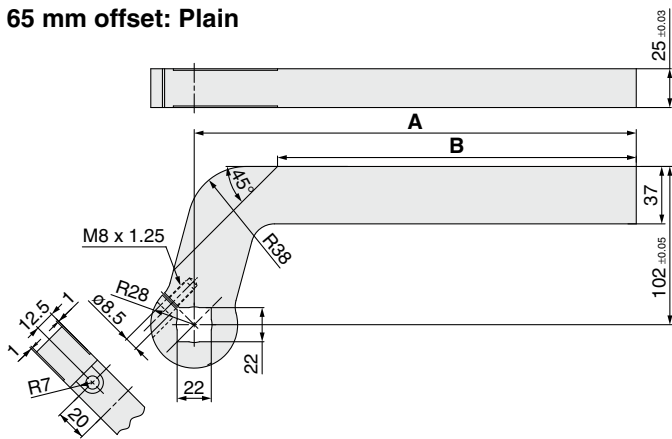

Part no.	NAAMS code	A	B	Weight [kg]
CKZ-63A025	ACA025M	135.0	81.3	1.7
CKZ-63A026	ACA026M	165.0	111.3	1.9
CKZ-63A027	ACA027M	195.0	141.3	2.1
CKZ-63A028	ACA028M	225.0	171.3	2.3
CKZ-63A029	ACA029M	255.0	201.3	2.5
CKZ-63A030	ACA030M	285.0	231.3	2.7

115 mm offset: Plain

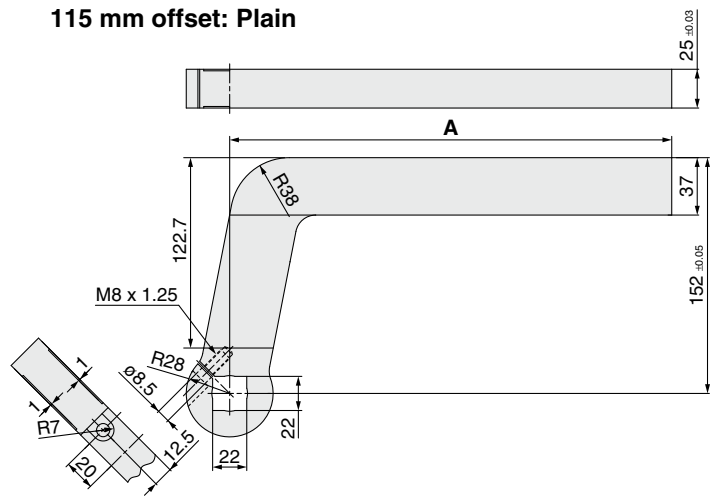

Part no.	NAAMS code	A	Weight [kg]
CKZ-63A037	ACA037M	135.0	2.1
CKZ-63A038	ACA038M	165.0	2.3
CKZ-63A039	ACA039M	195.0	2.5
CKZ-63A040	ACA040M	225.0	2.7
CKZ-63A041	ACA041M	255.0	2.9
CKZ-63A042	ACA042M	285.0	3.1

70 mm offset: Machined

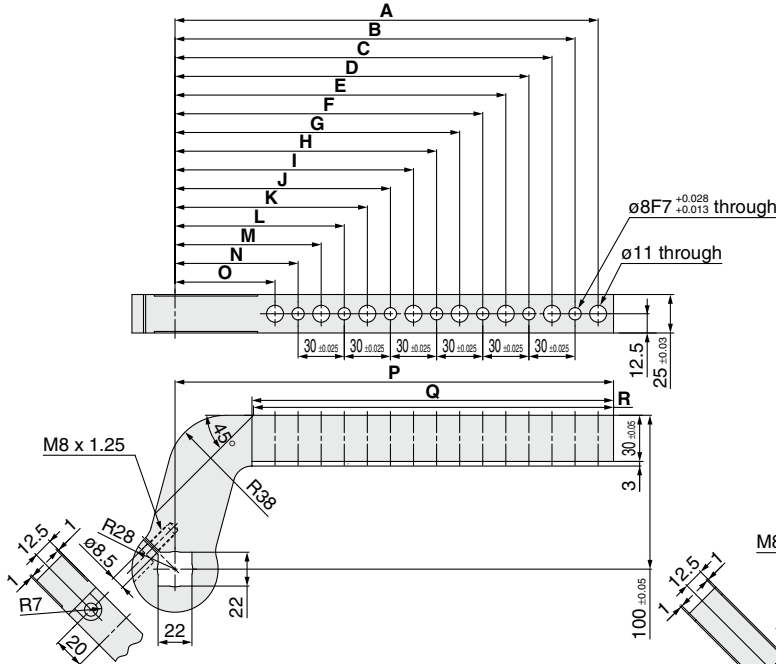

Part no.	NAAMS code	A	B	C	D	E	F	G	H	I	J
CKZ-63A031	ACA031M	125.0	110.0	95.0	80.0	65.0	—	—	—	—	—
CKZ-63A032	ACA032M	155.0	140.0	125.0	110.0	95.0	80.0	65.0	—	—	—
CKZ-63A033	ACA033M	185.0	170.0	155.0	140.0	125.0	110.0	95.0	80.0	65.0	—
CKZ-63A034	ACA034M	215.0	200.0	185.0	170.0	155.0	140.0	125.0	110.0	95.0	80.0
CKZ-63A035	ACA035M	245.0	230.0	215.0	200.0	185.0	170.0	155.0	140.0	125.0	110.0
CKZ-63A036	ACA036M	275.0	260.0	245.0	230.0	215.0	200.0	185.0	170.0	155.0	140.0

Part no.	NAAMS code	K	L	M	N	O	P	Q	R	Weight [kg]
CKZ-63A031	ACA031M	—	—	—	—	—	135.0	85.0	84.0	1.4
CKZ-63A032	ACA032M	—	—	—	—	—	165.0	115.0	114.0	1.6
CKZ-63A033	ACA033M	—	—	—	—	—	195.0	145.0	144.0	1.8
CKZ-63A034	ACA034M	65.0	—	—	—	—	225.0	175.0	174.0	1.9
CKZ-63A035	ACA035M	95.0	80.0	65.0	—	—	255.0	205.0	204.0	2.1
CKZ-63A036	ACA036M	125.0	110.0	95.0	80.0	65.0	285.0	235.0	234.0	2.3

120 mm offset: Machined

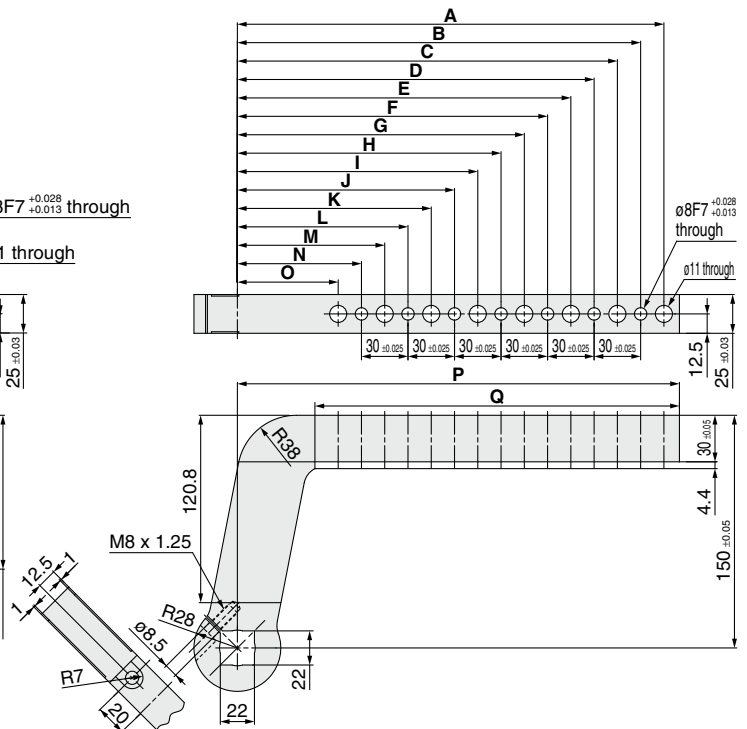

Part no.	NAAMS code	A	B	C	D	E	F	G	H	I	J
CKZ-63A043	ACA043M	125.0	110.0	95.0	80.0	65.0	—	—	—	—	—
CKZ-63A044	ACA044M	155.0	140.0	125.0	110.0	95.0	80.0	65.0	—	—	—
CKZ-63A045	ACA045M	185.0	170.0	155.0	140.0	125.0	110.0	95.0	80.0	65.0	—
CKZ-63A046	ACA046M	215.0	200.0	185.0	170.0	155.0	140.0	125.0	110.0	95.0	80.0
CKZ-63A047	ACA047M	245.0	230.0	215.0	200.0	185.0	170.0	155.0	140.0	125.0	110.0
CKZ-63A048	ACA048M	275.0	260.0	245.0	230.0	215.0	200.0	185.0	170.0	155.0	140.0

Part no.	NAAMS code	K	L	M	N	O	P	Q	Weight [kg]
CKZ-63A043	ACA043M	—	—	—	—	—	135.0	85.0	1.8
CKZ-63A044	ACA044M	—	—	—	—	—	165.0	115.0	2.0
CKZ-63A045	ACA045M	—	—	—	—	—	195.0	145.0	2.1
CKZ-63A046	ACA046M	65.0	—	—	—	—	225.0	175.0	2.3
CKZ-63A047	ACA047M	95.0	80.0	65.0	—	—	255.0	205.0	2.5
CKZ-63A048	ACA048M	125.0	110.0	95.0	80.0	65.0	285.0	235.0	2.6

Dimensions: Clamp Arm Bore Size 80

Straight: Plain

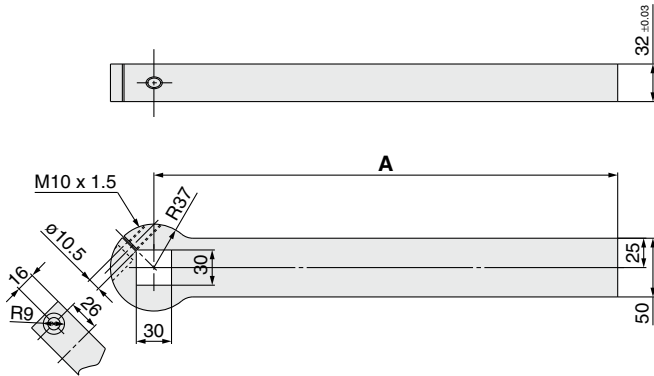

Part no.	NAAMS code	A	Weight [kg]
CKZ-80A001	ACA100M	155.0	2.3
CKZ-80A002	ACA101M	185.0	2.7
CKZ-80A003	ACA102M	215.0	3.0
CKZ-80A004	ACA103M	245.0	3.4
CKZ-80A005	ACA104M	275.0	3.8
CKZ-80A006	ACA105M	305.0	4.2
CKZ-80A007	ACA106M	335.0	4.5
CKZ-80A008	ACA107M	365.0	4.9
CKZ-80A009	ACA108M	395.0	5.3

20 mm offset: Plain

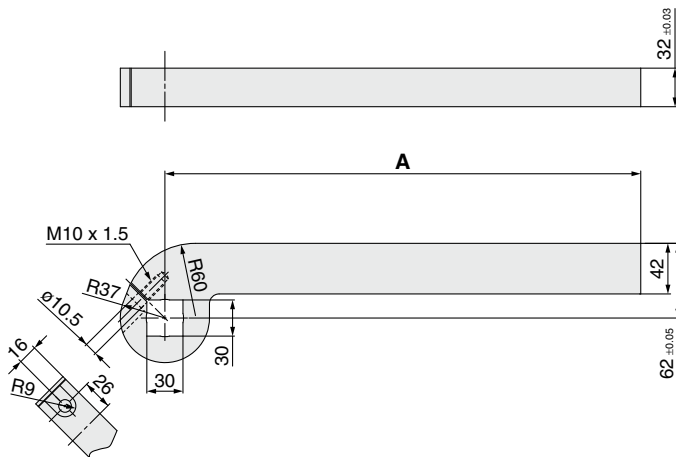

Part no.	NAAMS code	A	Weight [kg]
CKZ-80A019	ACA120M	155.0	2.4
CKZ-80A020	ACA121M	185.0	2.7
CKZ-80A021	ACA122M	215.0	3.0
CKZ-80A022	ACA123M	245.0	3.3
CKZ-80A023	ACA124M	275.0	3.6
CKZ-80A024	ACA125M	305.0	3.9
CKZ-80A025	ACA126M	335.0	4.2
CKZ-80A026	ACA127M	365.0	4.6
CKZ-80A027	ACA128M	395.0	4.9

Power Clamp Cylinders

CKZM16
CKZT25/32
CKZT40
CKZ3T
CKZT80
CKZ3N
CKZ2N

Related Products

C(L)KQG□ C(L)KQP□
C(L)KQ□D -X3256
C(L)KQG32 C(L)KU32
C(L)KQG32 -X3036
Flow Control Equipment
Piping Equipment

CKZ2N Series

Dimensions: Clamp Arm **Bore Size 80**

Straight: Machined

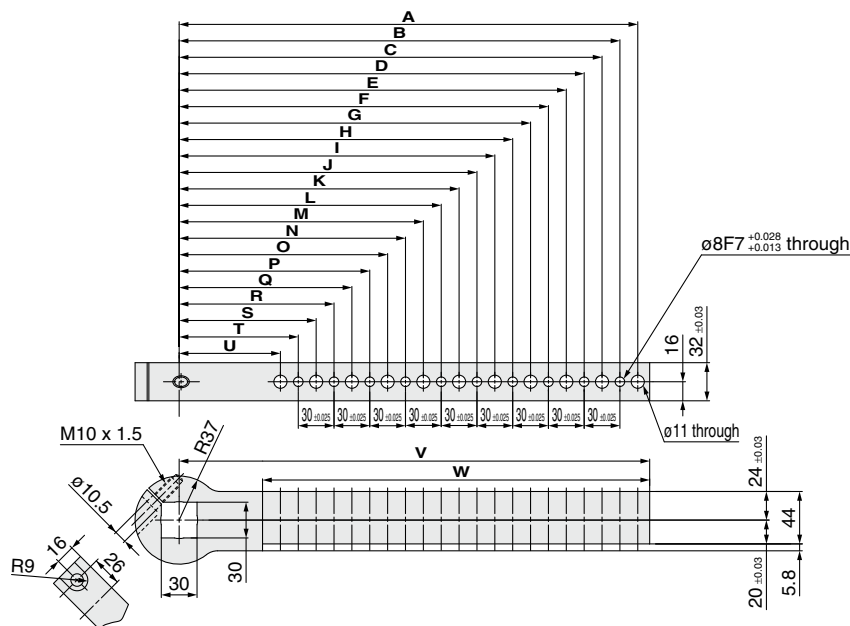

Part no.	NAAMS code	A	B	C	D	E	F	G	H	I	J	K	L	M	N	O	P	Q	R	S	T	U	V	W	Weight [kg]
CKZ-80A010	ACA110M	145.0	130.0	115.0	100.0	85.0	—	—	—	—	—	—	—	—	—	—	—	—	—	—	—	—	155.0	85.0	2.1
CKZ-80A011	ACA111M	175.0	160.0	145.0	130.0	115.0	100.0	85.0	—	—	—	—	—	—	—	—	—	—	—	—	—	—	185.0	115.0	2.4
CKZ-80A012	ACA112M	205.0	190.0	175.0	160.0	145.0	130.0	115.0	100.0	85.0	—	—	—	—	—	—	—	—	—	—	—	—	215.0	145.0	2.7
CKZ-80A013	ACA113M	235.0	220.0	205.0	190.0	175.0	160.0	145.0	130.0	115.0	100.0	85.0	—	—	—	—	—	—	—	—	—	—	245.0	175.0	3.0
CKZ-80A014	ACA114M	265.0	250.0	235.0	220.0	205.0	190.0	175.0	160.0	145.0	130.0	115.0	100.0	85.0	—	—	—	—	—	—	—	—	275.0	205.0	3.3
CKZ-80A015	ACA115M	295.0	280.0	265.0	250.0	235.0	220.0	205.0	190.0	175.0	160.0	145.0	130.0	115.0	100.0	85.0	—	—	—	—	—	—	305.0	235.0	3.6
CKZ-80A016	ACA116M	325.0	310.0	295.0	280.0	265.0	250.0	235.0	220.0	205.0	190.0	175.0	160.0	145.0	130.0	115.0	100.0	85.0	—	—	—	—	335.0	265.0	3.9
CKZ-80A017	ACA117M	355.0	340.0	325.0	310.0	295.0	280.0	265.0	250.0	235.0	220.0	205.0	190.0	175.0	160.0	145.0	130.0	115.0	100.0	85.0	—	—	365.0	295.0	4.2
CKZ-80A018	ACA118M	385.0	370.0	355.0	340.0	325.0	310.0	295.0	280.0	265.0	250.0	235.0	220.0	205.0	190.0	175.0	160.0	145.0	130.0	115.0	100.0	85.0	395.0	325.0	4.5

25 mm offset: Machined

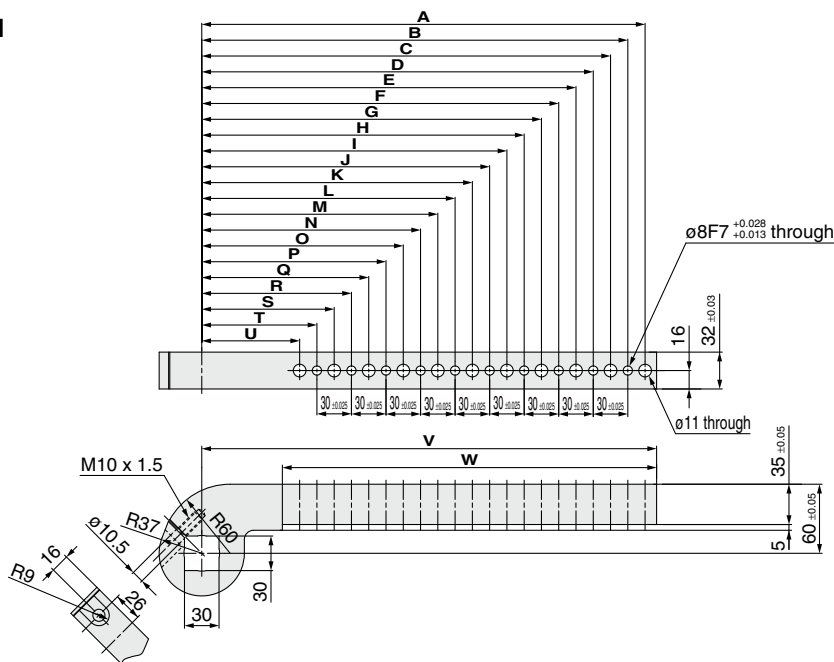

Part no.	NAAMS code	A	B	C	D	E	F	G	H	I	J	K	L	M	N	O	P	Q	R	S	T	U	V	W	Weight [kg]
CKZ-80A028	ACA130M	145.0	130.0	115.0	100.0	85.0	—	—	—	—	—	—	—	—	—	—	—	—	—	—	—	—	155.0	85.0	2.1
CKZ-80A029	ACA131M	175.0	160.0	145.0	130.0	115.0	100.0	85.0	—	—	—	—	—	—	—	—	—	—	—	—	—	—	185.0	115.0	2.3
CKZ-80A030	ACA132M	205.0	190.0	175.0	160.0	145.0	130.0	115.0	100.0	85.0	—	—	—	—	—	—	—	—	—	—	—	—	215.0	145.0	2.6
CKZ-80A031	ACA133M	235.0	220.0	205.0	190.0	175.0	160.0	145.0	130.0	115.0	100.0	85.0	—	—	—	—	—	—	—	—	—	—	245.0	175.0	2.8
CKZ-80A032	ACA134M	265.0	250.0	235.0	220.0	205.0	190.0	175.0	160.0	145.0	130.0	115.0	100.0	85.0	—	—	—	—	—	—	—	—	275.0	205.0	3.0
CKZ-80A033	ACA135M	295.0	280.0	265.0	250.0	235.0	220.0	205.0	190.0	175.0	160.0	145.0	130.0	115.0	100.0	85.0	—	—	—	—	—	—	305.0	235.0	3.2
CKZ-80A034	ACA136M	325.0	310.0	295.0	280.0	265.0	250.0	235.0	220.0	205.0	190.0	175.0	160.0	145.0	130.0	115.0	100.0	85.0	—	—	—	—	335.0	265.0	3.5
CKZ-80A035	ACA137M	355.0	340.0	325.0	310.0	295.0	280.0	265.0	250.0	235.0	220.0	205.0	190.0	175.0	160.0	145.0	130.0	115.0	100.0	85.0	—	—	365.0	295.0	3.8
CKZ-80A036	ACA138M	385.0	370.0	355.0	340.0	325.0	310.0	295.0	280.0	265.0	250.0	235.0	220.0	205.0	190.0	175.0	160.0	145.0	130.0	115.0	100.0	85.0	395.0	325.0	4.0

Dimensions: Clamp Arm Bore Size 80

65 mm offset: Plain

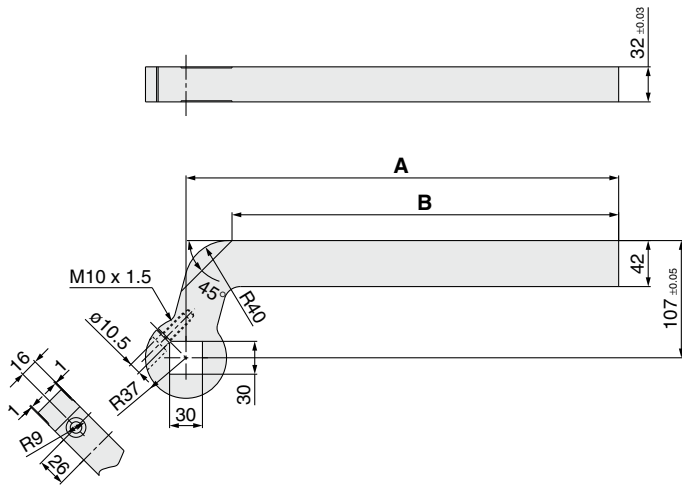

Part no.	NAAMS code	A	B	Weight [kg]
CKZ-80A037	ACA140M	155.0	113.0	2.7
CKZ-80A038	ACA141M	185.0	143.0	3.0
CKZ-80A039	ACA142M	215.0	173.0	3.3
CKZ-80A040	ACA143M	245.0	203.0	3.6
CKZ-80A041	ACA144M	275.0	233.0	3.9
CKZ-80A042	ACA145M	305.0	263.0	4.2
CKZ-80A043	ACA146M	335.0	293.0	4.5
CKZ-80A044	ACA147M	365.0	323.0	4.8
CKZ-80A045	ACA148M	395.0	353.0	5.1

115 mm offset: Plain

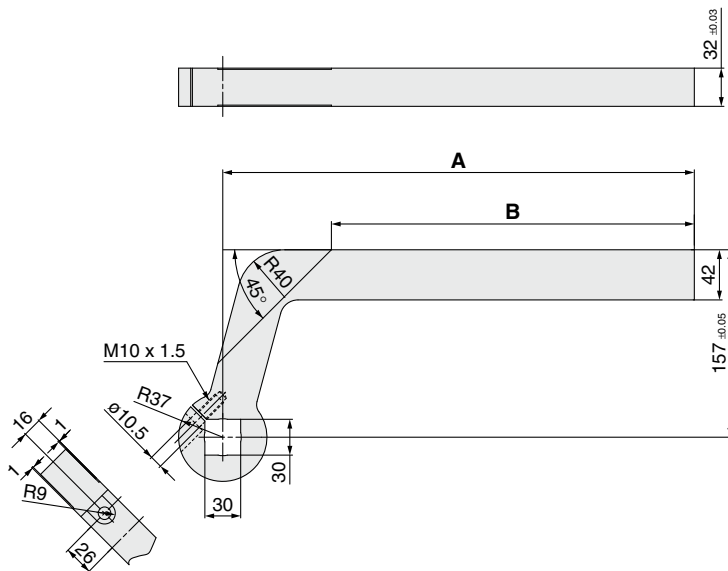

Part no.	NAAMS code	A	B	Weight [kg]
CKZ-80A055	ACA160M	155.0	64.0	3.0
CKZ-80A056	ACA161M	185.0	94.0	3.3
CKZ-80A057	ACA162M	215.0	124.0	3.6
CKZ-80A058	ACA163M	245.0	154.0	3.9
CKZ-80A059	ACA164M	275.0	184.0	4.2
CKZ-80A060	ACA165M	305.0	214.0	4.5
CKZ-80A061	ACA166M	335.0	244.0	4.8
CKZ-80A062	ACA167M	365.0	274.0	5.2
CKZ-80A063	ACA168M	395.0	304.0	5.5

- Power Clamp Cylinders
- CKZM16
 - CKZT25/32
 - CKZT40
 - CKZ3T
 - CKZT80
 - CKZ3N
 - CKZ2N

- Related Products
- C(L)KQG□
 - C(L)KQP□
 - C(L)KQ□D
 - X3256
 - C(L)KQG32
 - C(L)KU32
 - C(L)KQG32
 - X3036
 - Flow Control Equipment
 - Piping Equipment

CKZ2N Series

Dimensions: Clamp Arm **Bore Size 80**

70 mm offset: Machined

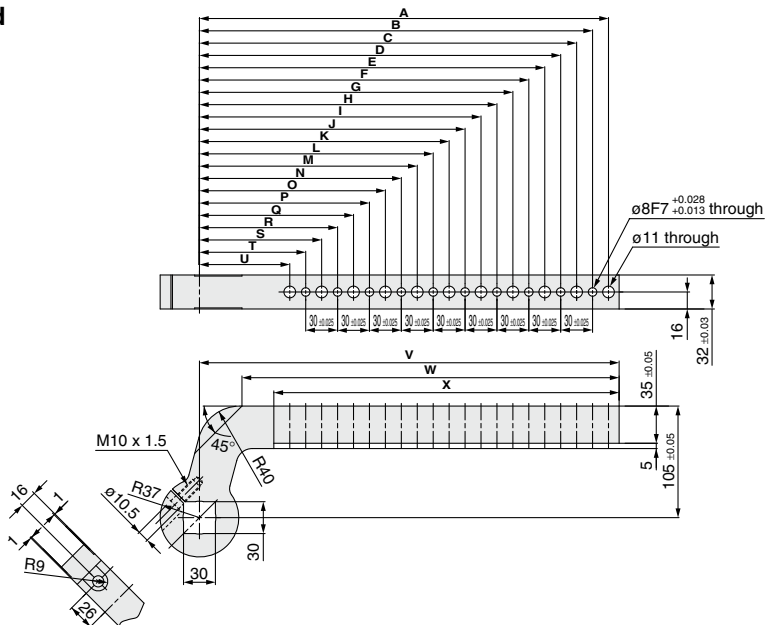

Part no.	NAAMS code	A	B	C	D	E	F	G	H	I	J	K	L	M	N	O	P	Q	R	S	T	U	V	W	X	Weight [kg]
CKZ-80A046	ACA150M	145.0	130.0	115.0	100.0	85.0	—	—	—	—	—	—	—	—	—	—	—	—	—	—	—	—	155.0	115.0	85.0	2.4
CKZ-80A047	ACA151M	175.0	160.0	145.0	130.0	115.0	100.0	85.0	—	—	—	—	—	—	—	—	—	—	—	—	—	—	185.0	145.0	115.0	2.6
CKZ-80A048	ACA152M	205.0	190.0	175.0	160.0	145.0	130.0	115.0	100.0	85.0	—	—	—	—	—	—	—	—	—	—	—	—	215.0	175.0	145.0	2.8
CKZ-80A049	ACA153M	235.0	220.0	205.0	190.0	175.0	160.0	145.0	130.0	115.0	100.0	85.0	—	—	—	—	—	—	—	—	—	—	245.0	205.0	175.0	3.1
CKZ-80A050	ACA154M	265.0	250.0	235.0	220.0	205.0	190.0	175.0	160.0	145.0	130.0	115.0	100.0	85.0	—	—	—	—	—	—	—	—	275.0	235.0	205.0	3.3
CKZ-80A051	ACA155M	295.0	280.0	265.0	250.0	235.0	220.0	205.0	190.0	175.0	160.0	145.0	130.0	115.0	100.0	85.0	—	—	—	—	—	—	305.0	265.0	235.0	3.5
CKZ-80A052	ACA156M	325.0	310.0	295.0	280.0	265.0	250.0	235.0	220.0	205.0	190.0	175.0	160.0	145.0	130.0	115.0	100.0	85.0	—	—	—	—	335.0	295.0	265.0	3.8
CKZ-80A053	ACA157M	355.0	340.0	325.0	310.0	295.0	280.0	265.0	250.0	235.0	220.0	205.0	190.0	175.0	160.0	145.0	130.0	115.0	100.0	85.0	—	—	365.0	325.0	295.0	4.0
CKZ-80A054	ACA158M	385.0	370.0	355.0	340.0	325.0	310.0	295.0	280.0	265.0	250.0	235.0	220.0	205.0	190.0	175.0	160.0	145.0	130.0	115.0	100.0	85.0	395.0	355.0	325.0	4.3

120 mm offset: Machined

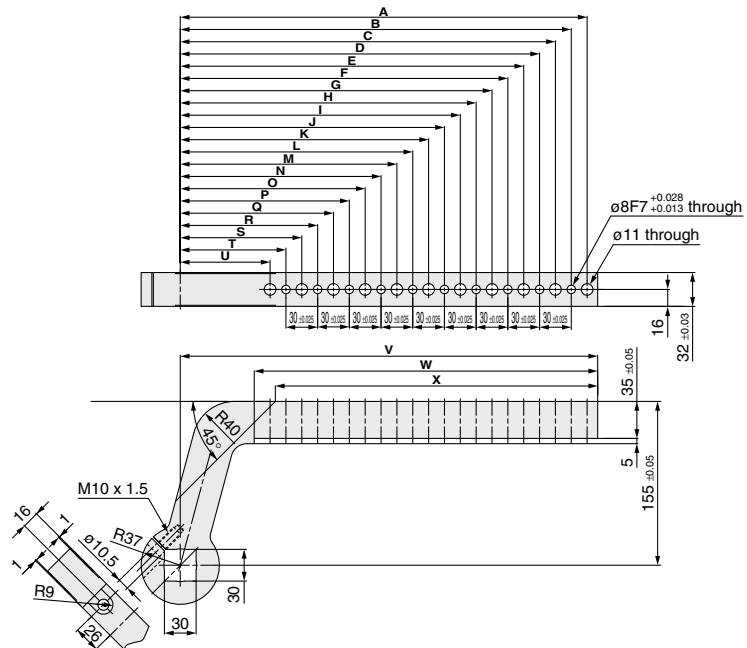

Part no.	NAAMS code	A	B	C	D	E	F	G	H	I	J	K	L	M	N	O	P	Q	R	S	T	U	V	W	X	Weight [kg]
CKZ-80A064	ACA170M	145.0	130.0	115.0	100.0	85.0	—	—	—	—	—	—	—	—	—	—	—	—	—	—	—	—	155.0	85.0	65.0	2.7
CKZ-80A065	ACA171M	175.0	160.0	145.0	130.0	115.0	100.0	85.0	—	—	—	—	—	—	—	—	—	—	—	—	—	—	185.0	115.0	95.0	2.9
CKZ-80A066	ACA172M	205.0	190.0	175.0	160.0	145.0	130.0	115.0	100.0	85.0	—	—	—	—	—	—	—	—	—	—	—	—	215.0	145.0	125.0	3.2
CKZ-80A067	ACA173M	235.0	220.0	205.0	190.0	175.0	160.0	145.0	130.0	115.0	100.0	85.0	—	—	—	—	—	—	—	—	—	—	245.0	175.0	155.0	3.4
CKZ-80A068	ACA174M	265.0	250.0	235.0	220.0	205.0	190.0	175.0	160.0	145.0	130.0	115.0	100.0	85.0	—	—	—	—	—	—	—	—	275.0	205.0	185.0	3.6
CKZ-80A069	ACA175M	295.0	280.0	265.0	250.0	235.0	220.0	205.0	190.0	175.0	160.0	145.0	130.0	115.0	100.0	85.0	—	—	—	—	—	—	305.0	235.0	215.0	3.9
CKZ-80A070	ACA176M	325.0	310.0	295.0	280.0	265.0	250.0	235.0	220.0	205.0	190.0	175.0	160.0	145.0	130.0	115.0	100.0	85.0	—	—	—	—	335.0	265.0	245.0	4.1
CKZ-80A071	ACA177M	355.0	340.0	325.0	310.0	295.0	280.0	265.0	250.0	235.0	220.0	205.0	190.0	175.0	160.0	145.0	130.0	115.0	100.0	85.0	—	—	365.0	295.0	275.0	4.4
CKZ-80A072	ACA178M	385.0	370.0	355.0	340.0	325.0	310.0	295.0	280.0	265.0	250.0	235.0	220.0	205.0	190.0	175.0	160.0	145.0	130.0	115.0	100.0	85.0	395.0	325.0	305.0	4.6

CKZ2N Series Model Selection

Relation between arm length and clamping force

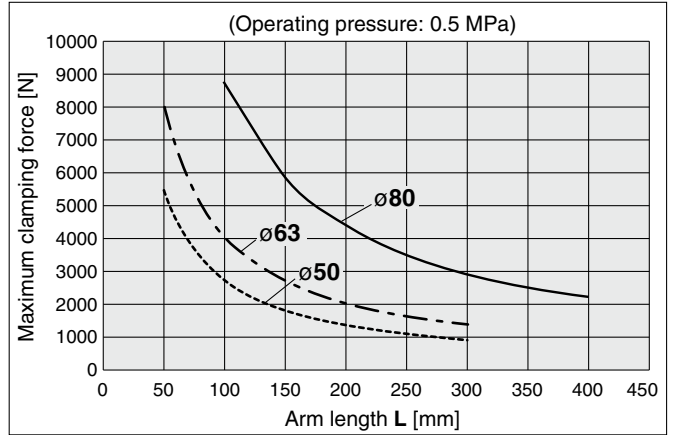
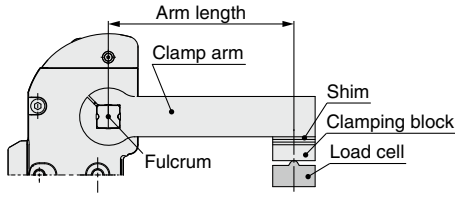

Allowable arm length

Allowable arm length

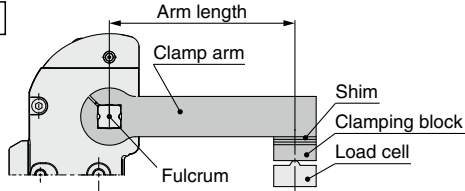

Bore size	Allowable arm length [mm]
50	300
63	300
80	400

Allowable load mass

The allowable load mass changes depending on the arm opening angle.
Be sure to use the product within the allowable values shown in the graphs below.
* The load indicates the total weight of the clamp arm and clamping block.
* When the operating time is 1 second

Calculation procedure for allowable load mass

1. Calculate the distance L from the fulcrum to the load center of gravity.
2. Check the arm opening angle of the product.
3. Read the allowable load mass from the graph.

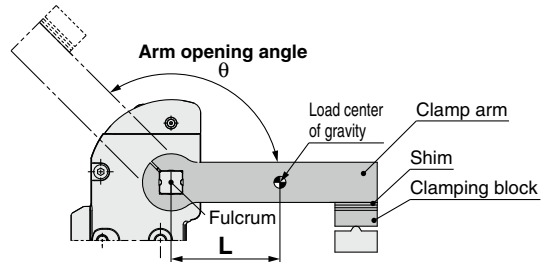

Bore Size: 50

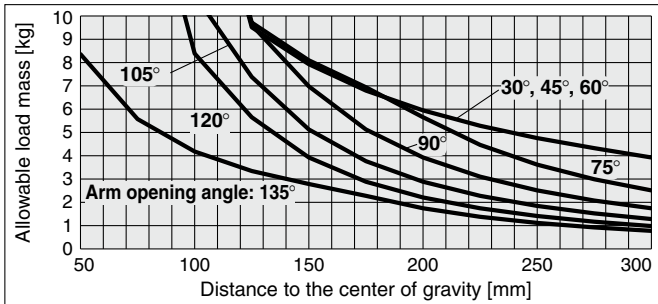

Bore Size: 63

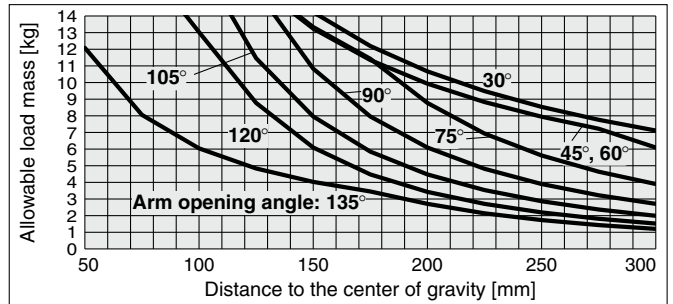

Bore Size: 80

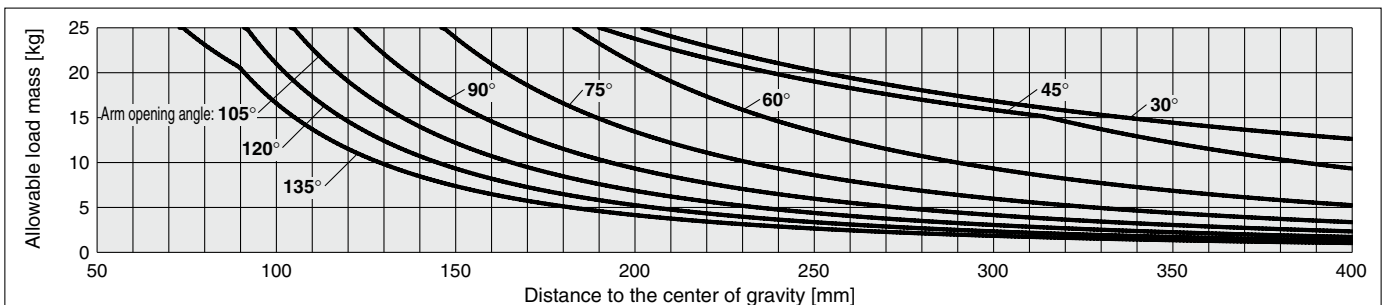

Power Clamp Cylinders
CKZM16
CKZT25/32
CKZT40
CKZ3T
CKZT80
CKZ3N
CKZ2N

Related Products
C(L)KQG□
C(L)KQP□
C(L)KQ□D
-X3256
C(L)KQG32
C(L)KU32
C(L)KQG32
-X3036
Flow Control Equipment
Piping Equipment

CKZ2N Series Setup Procedure

Precautions

- 1) The tightening torque of the clamp arm is 12 to 15 N·m for $\phi 50$, 15 to 20 N·m for $\phi 63$, and 18 to 24 N·m for $\phi 80$. Refer to pages 92 to 99 for details on the clamp arm.
- 2) This product is designed to be used after being externally adjusted using a shim, and there is a mechanical difference of 0 to $+0.5^\circ$ at the clamping end as shown in Figure 1.
- 3) Be sure to use a speed controller, and make adjustments according to the following conditions.

Unclamping to clamping: 1 second or more

Clamping to unclamping: 1 second or more

If excessive kinetic energy is applied, there is a possibility of damage.

- 4) When using a side guide:

Attach the side guide so that lateral loads, such as galling, etc., are not applied to the clamp arm.

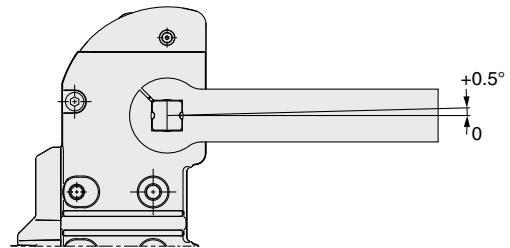
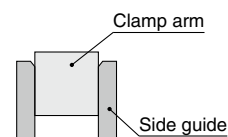
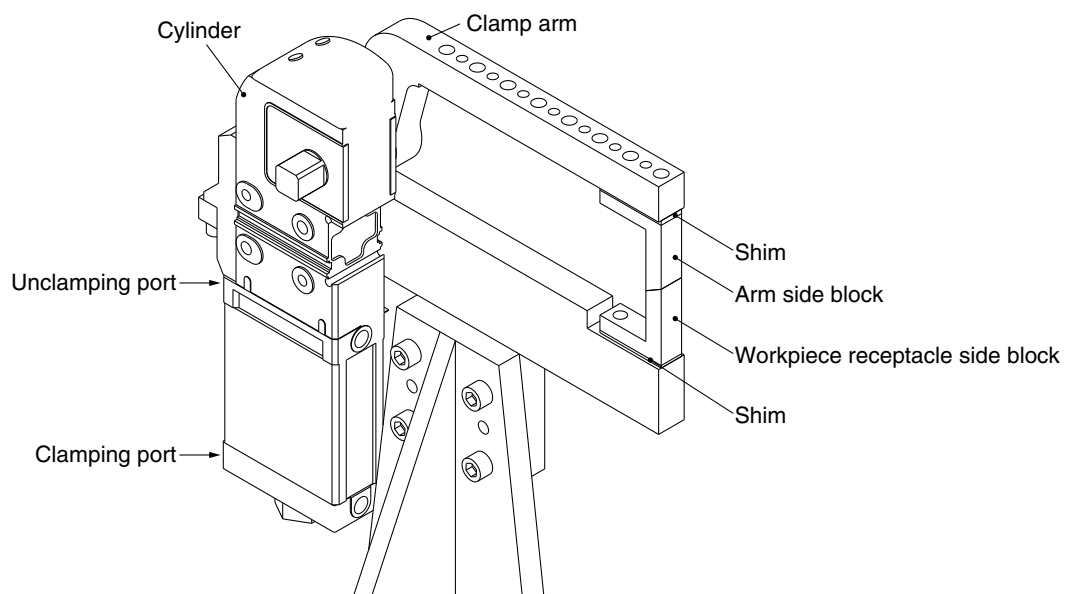

Figure 1



Power clamp cylinder mounting and setup procedure

<Ex. 1 When using clamping force only: When equipped with a workpiece receptacle>



Procedure

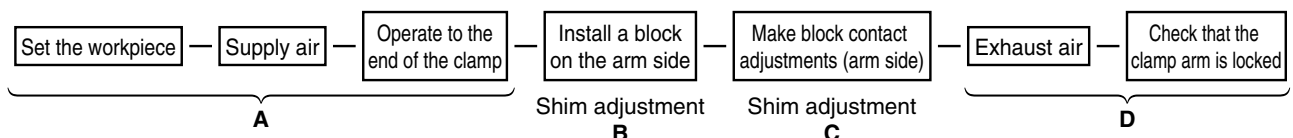

- A) Place the workpiece, supply air to the clamping port without attaching the block on the arm side, and operate the clamp arm to the end of the clamp.
- B) In the state of A), attach the workpiece and the arm side block, and adjust the shim so that there is a space of about 0 mm. During this step, theoretically, there is no clamping force pressing down on the workpiece.
- C) In order to generate a clamping force from the state described in step B), insert an additional shim. The thickness of the shim changes depending on the arm length and the operating pressure. Refer to page 103. Please note that the graph should only be used as a guide as there is a tolerance of about 10% in the clamp cylinder body.
- D) Exhaust the air while in the clamped state, and confirm that the clamp arm does not open.

Power clamp cylinder mounting and setup procedure

<Ex. 2 When using a hard stop: When not equipped with a workpiece receptacle>

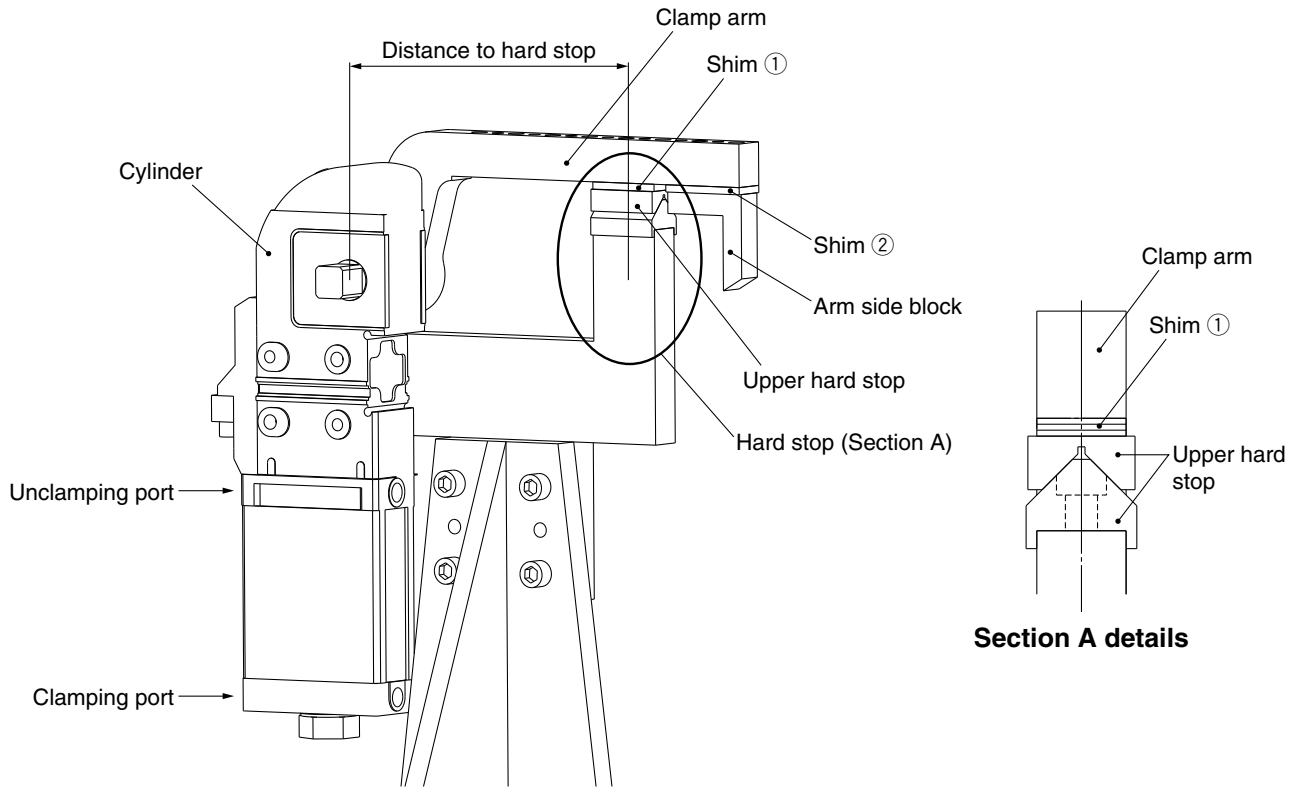

Procedure

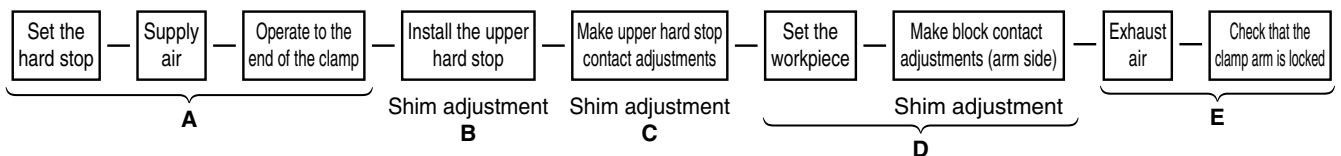

- A) Supply air to the clamping port without installing the upper hard stop, and operate the clamp arm to the end of the clamp.
- B) In the state of A), attach the upper hard stop and adjust shim ① so that there is a space of about 0 mm between the upper hard stop and the hard stop.
During this step, theoretically, there is no clamping force applied to the hard stop.
- C) In order to generate a clamping force from the state described in step B), insert an additional shim.
The thickness of the shim changes depending on the distance to the hard stop and the operating pressure. Refer to page 103, and consider the distance to the hard stop as the arm length.
Please note that the graph should only be used as a guide as there is a tolerance of about 10% in the clamp cylinder body.
- D) In the state of C), adjust shim ② so that the arm side block contacts the workpiece.
- E) Exhaust the air while in the clamped state, and confirm that the clamp arm does not open.

CKZM16
CKZT25/32
CKZT40
Power Clamp Cylinders
CKZ3T
CKZT80
CKZ3N
CKZ2N

C(L)KQG□
C(L)KQP□
C(L)KQ□D
-X3256
Related Products
C(L)KQG32
C(L)KU32
C(L)KQG32
-X3036
Flow Control Equipment
Piping Equipment

Relation between shim thickness and clamping force

- * Use this figure as a guide as there is a tolerance of about 10% in the clamp cylinder body.
- * When a shim exceeding the peak clamping force position on the graph is inserted, the lock will not be activated when clamped. Insert a shim of the appropriate thickness.

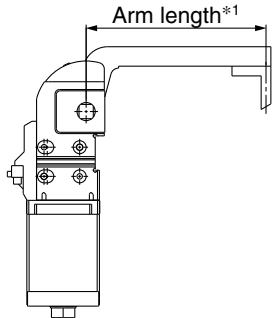

*1 The arm length indicates the distance between the clamp arm shaft and the clamping position.

ø50

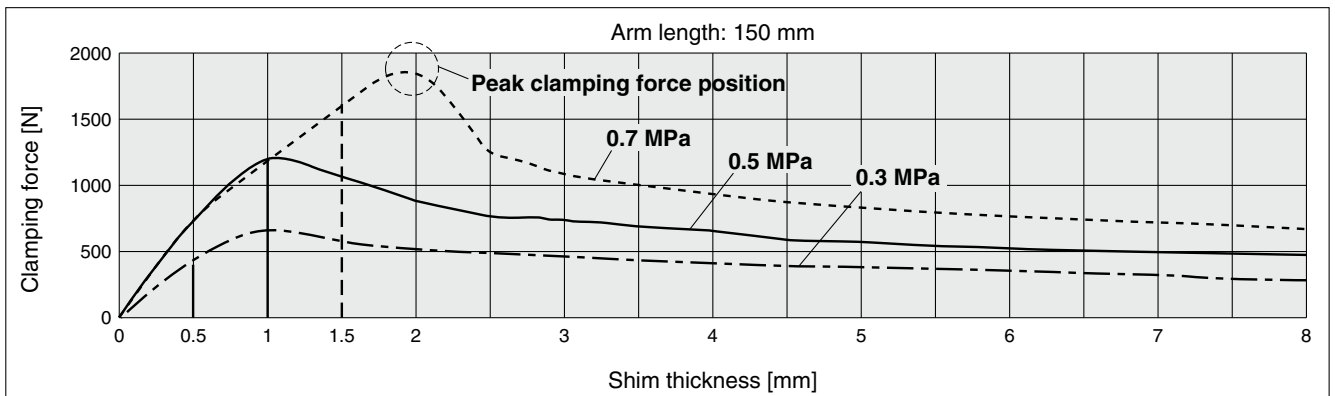

ø63

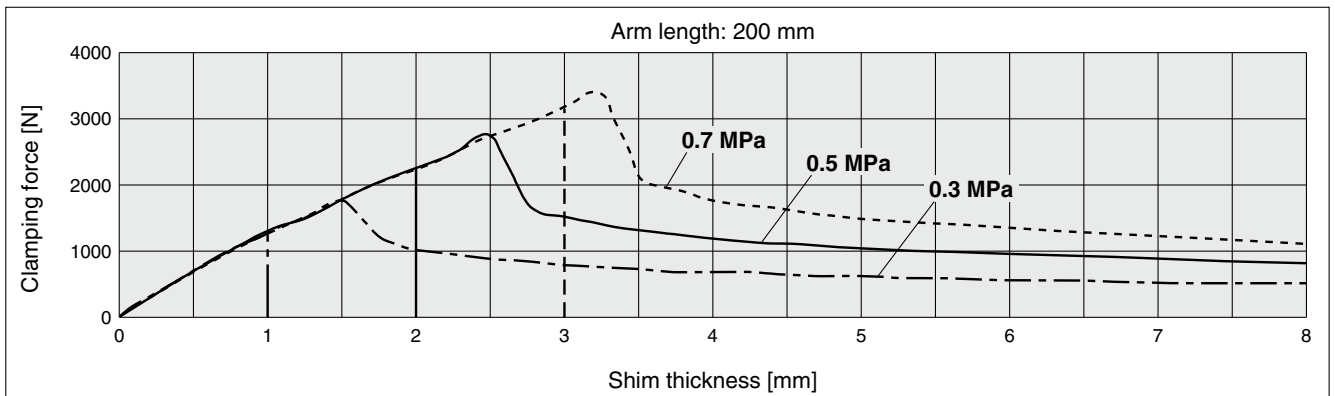

ø80

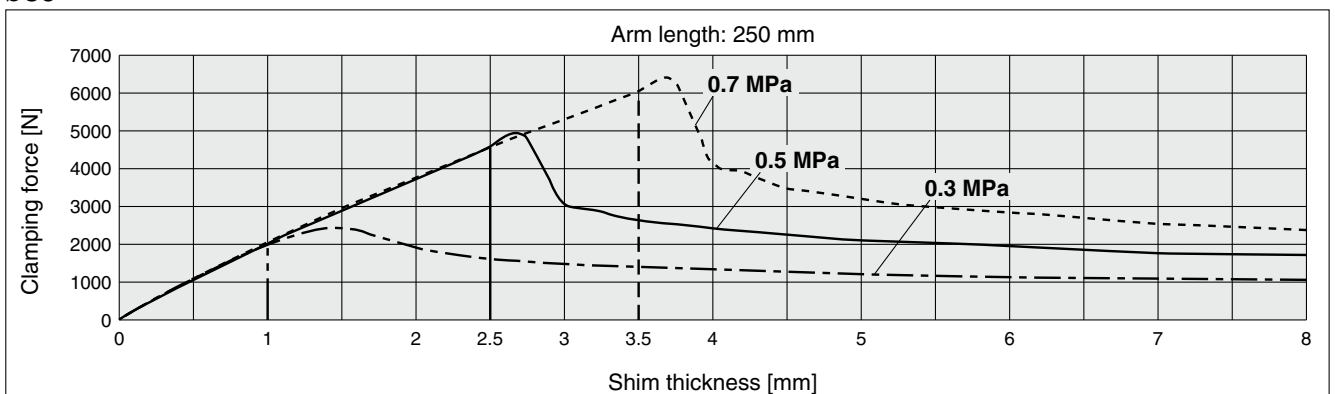

To change the arm opening angle

⚠ Caution Be sure to confirm safety, and perform the work while the air is exhausted.

Procedure for changing the arm opening angle

- 1) When changing the arm opening angle, be sure to confirm that the air inside the cylinder has been exhausted.
- 2) Remove the switch cassette.
 - * 8 types of arm opening angles (unclamping angles) 30°, 45°, 60°, 75°, 90°, 105°, 120°, and 135° are available for each standard size.

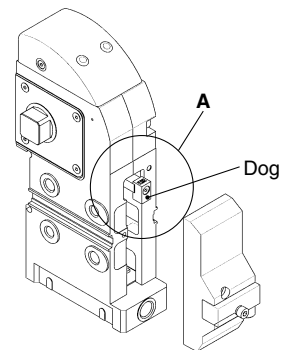

- 3) Remove the dog of the A part, and mount a different dog for other angles using the tightening torque below. (Confirm the direction of the angle display.) Then mount the switch cassette using the tightening torque below.

Description	Bore size [mm]	Tightening torque
		N·m
Dog	50	3.0 to 4.0
	63	3.0 to 4.0
	80	3.0 to 4.0
Switch cassette	50	5.0 to 7.0
	63	5.0 to 7.0
	80	5.0 to 7.0

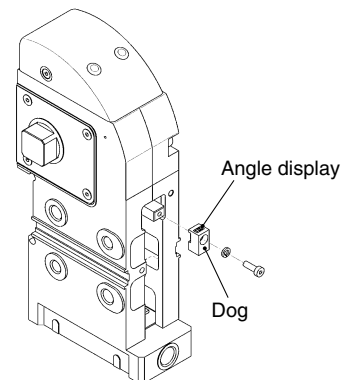

- 4) Remove the stopper bolt of the head cover, and mount a different stopper bolt for other angles using the tightening torque below. (Confirm the angle display.)

Description	Bore size [mm]	Tightening torque
		N·m
Stopper bolt	50	45 to 65
	63	85 to 115
	80	130 to 190

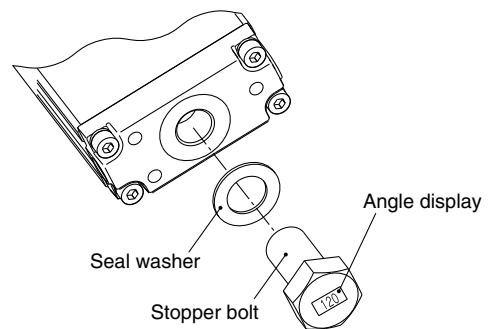

Top cover replacement

⚠ Caution Be sure to confirm safety, and perform the work while the air is exhausted.

- 1) Mount the top cover to the clamp cylinder, then tighten it to the specified tightening torque below.
- * Refer to Replacement Parts (page 89) for the part numbers of the top cover replacement parts.

Description	Bore size [mm]	Tightening torque
		N·m
Top cover kit	50	2.5 to 3.0
	63	2.5 to 3.0
	80	3.0 to 5.0

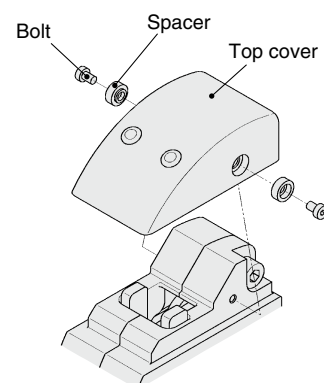

Rubber cover type

Power Clamp Cylinders	CKZM16
	CKZT25/32
	CKZT40
	CKZ3T
	CKZT80
CKZ3N	CKZ3N
	CKZ2N
Related Products	C(L)KQG□ C(L)KQP□
	C(L)KQ□D -X3256
	C(L)KQG32 C(L)KU32
	C(L)KQG32 -X3036
Flow Control Equipment	
Piping Equipment	



CKZ2N Series Specific Product Precautions

Be sure to read this before handling the products. Refer to page 151 for safety instructions. For actuator precautions, refer to the “Handling Precautions for SMC Products” and the “Operation Manual” on the SMC website: <https://www.smcworld.com>

⚠ Caution

1. Manual lock release

Be sure to confirm safety before manually releasing the lock, and only perform work while the air is exhausted. Otherwise, the clamp arm may operate unexpectedly.

- In the case of a rubber cover, the lock can be released easily by hitting the round tab on the cover with a plastic hammer.

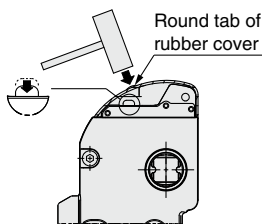

Rubber cover type

- Provide enough space to perform a manual lock release.

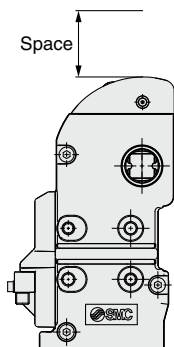

Rubber cover type

2. Do not disassemble the power clamp cylinder.

The power clamp cylinder consists of a completely sealed structure in order to protect it from welding spatter. Do not disassemble, except for when replacing any of the replaceable parts, as this may cause the performance to deteriorate.

3. Clamp arm

The clamp arm may interfere with the cylinder body depending on the mounting method. Be sure to check for interference.

4. Proximity switch output

The switch output signal is output near the clamping end and the unclamping end respectively.

The switch output signal on the clamping side does not output the status where the power clamp cylinder is locked by the toggle mechanism.

5. Operating time and allowable load mass

Fast operation (short stroke times) or excessive loads will lead to the breakage or deformation of the product. It is recommended to install shock absorbers to reduce impact force in these instances.