

# Power Clamp Cylinder

## CKZT Series

ø40

Lightweight

Compact

High clamping force

Lock function

Weight : 1.6 kg

Compact Width : 54 mm

Height : 265.9 mm

Clamping force : 1200 N

(Arm length: 100 mm, 0.5 MPa pressure)

### Force amplification with a toggle mechanism and lock function

Can hold a clamped state when supply pressure drops or residual pressure is released

### Spatter-proof construction

Fully closed structure prevents the intrusion of spatter

Equipped with a proximity switch that can be used in welding magnetic fields

Selectable metal or rubber cover

Manual handle lock is available for small bore sizes.

- For manual workpiece setting processes
- The handle is held at unclamped position.

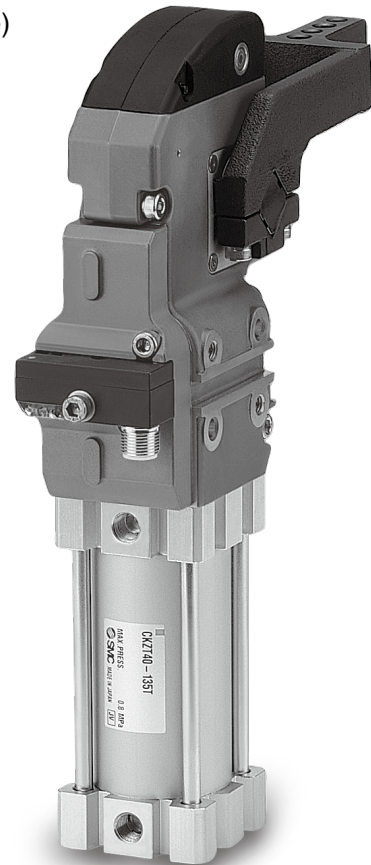

CKZM16

CKZT25/32

CKZT40

Power Clamp Cylinders

CKZ3T

CKZT80

CKZ3N

CKZ2N

C(L)KQG□  
C(L)KQP□

C(L)KQ□D  
-X3256

C(L)KQG32  
C(L)KU32

C(L)KQG32  
-X3036

Flow Control  
Equipment

Piping  
Equipment

Related Products



## Cylinder Specifications

Bore size [mm]	<b>40</b>
Action	Double acting
Fluid	Air
Proof pressure	1.2 MPa
Max. operating pressure	0.8 MPa
Min. operating pressure	0.3 MPa
Ambient and fluid temperatures	-10 to 60°C
Cushion	Clamping side: None Unclamping side: Rubber bumper
Operating time	Clamping: 1 s or more, Unclamping: 1 s or more
Max. allowable holding moment*1	380 N·m

\*1 Refer to the maximum holding force (torque) while clamped with the operating air exhausted.  
This is not the possible holding force (torque) for normal use.

## Weight (Cylinder Without Arm)

Bore size [mm]	Base type	Extra weight is due to addition of the manually operated handle	Extra weight is due to addition of the manual handle lock
<b>40</b>	1.6	0.8	1.1

## Cylinder Stroke

Bore size \ Angle	[mm]							
	30°	45°	60°	75°	90°	105°	120°	135°
<b>40</b>	26.8	33.3	39.6	45.9	52.3	58.4	63.6	67.3

## Proximity Switch Specifications

Manufacturer	TURCK	P&F
Power supply voltage	10 to 30 VDC	10 to 30 VDC
Output	N.O., PNP	N.O., PNP
Continuous load current	150 mA	100 mA
Response frequency	30 Hz	25 Hz
Housing material	PBT	PA6, PBT
Output indication	Clamping side: Red Unclamping side: Yellow	Clamping side: Red Unclamping side: Yellow
Power supply indication	Green	Green
Connector	M12 connector	M12 connector

\* Switch specifications correspond to the manufacturers' technical information.

## Wiring Diagram (PNP Connection Circuit)

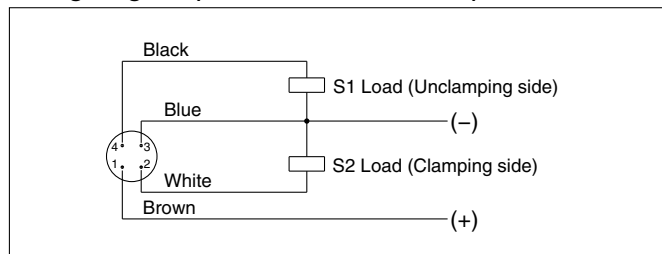

\* Applicable to both TURCK and P&F  
\* Please contact SMC for NPN specifications.

CKZM16

CKZT25/32

CKZT40

CKZ3T

CKZT80

CKZ3N

CKZ2N

C(L)KQG□  
C(L)KQP□

C(L)KQ□D  
-X3256

C(L)KQG32  
C(L)KU32

C(L)KQG32  
-X3036

Flow Control  
Equipment

Piping  
Equipment

# CKZT Series

## Replacement Parts

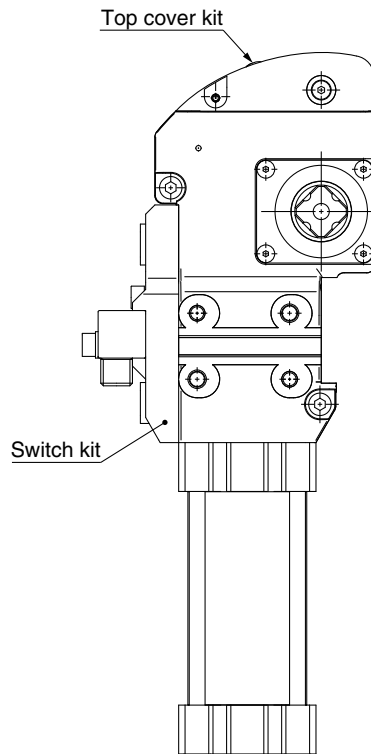

### Switch Kit No.

**CKZT-S 040 T**

Bore size • Proximity switch

T	TURCK
P	P&F

\* The switch kit includes a switch holder, proximity switch, and mounting brackets.

### Top Cover Kit No.

Rubber cover

**CKZT-T 040**

• Bore size

Metal cover

**CKZ40-53-1041T-R**

\* The top cover kit includes a top cover and mounting brackets.  
 \* Refer to page 37 for the procedure for changing the arm opening angle and top cover replacement instructions.

### Kit No. for Changing the Arm Opening Angle (For details, refer to page 37.)

**CKZT- [ ] 040 [ ]**

Kit type • Bore size • Arm opening angle

B	Stopper bolt kit
D	Dog kit
K	A set of B and D

H	30°
G	45°
F	60°
E	75°
D	90°
C	105°
B	120°
A	135°

\* The stopper bolt kit includes a stopper bolt and mounting brackets.  
 \* The dog kit includes a dog and mounting brackets.



# CKZT Series

## Dimensions

\* Refer to the CKZT40 (page 30) for dimensions other than those shown below.

With manually operated handle

CKZT40-□-X2798<sup>L</sup><sub>R</sub> (Rubber cover)

CKZT40-□-X3174<sup>L</sup><sub>R</sub> (Metal cover)

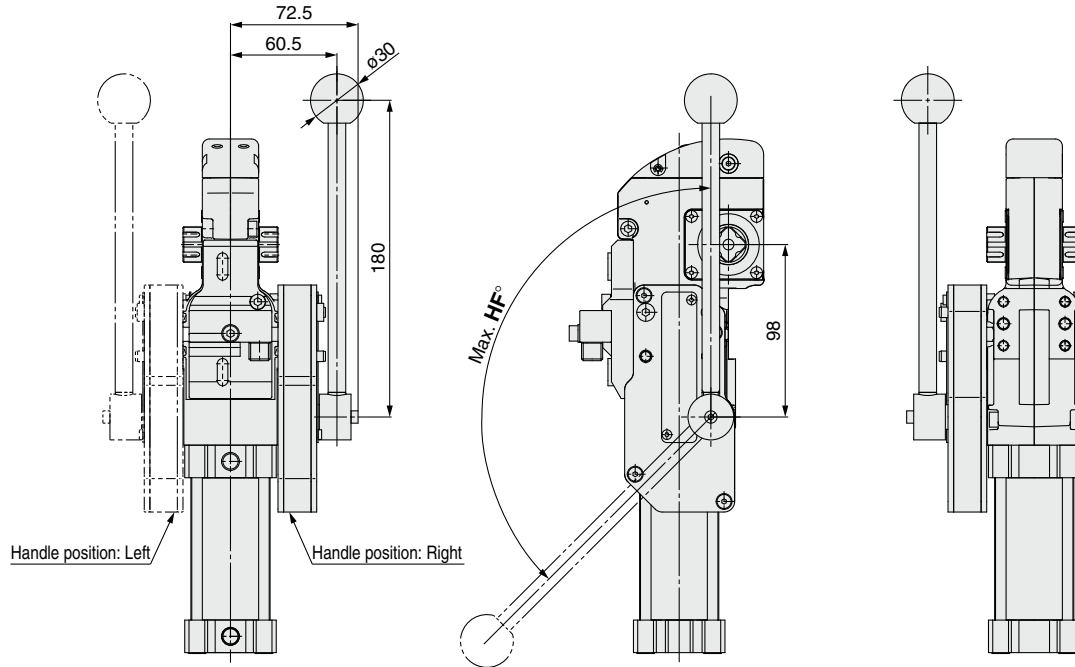

With manual handle lock

CKZT40-□-X3232<sup>L</sup><sub>R</sub> (Rubber cover)

CKZT40-□-X3229<sup>L</sup><sub>R</sub> (Metal cover)

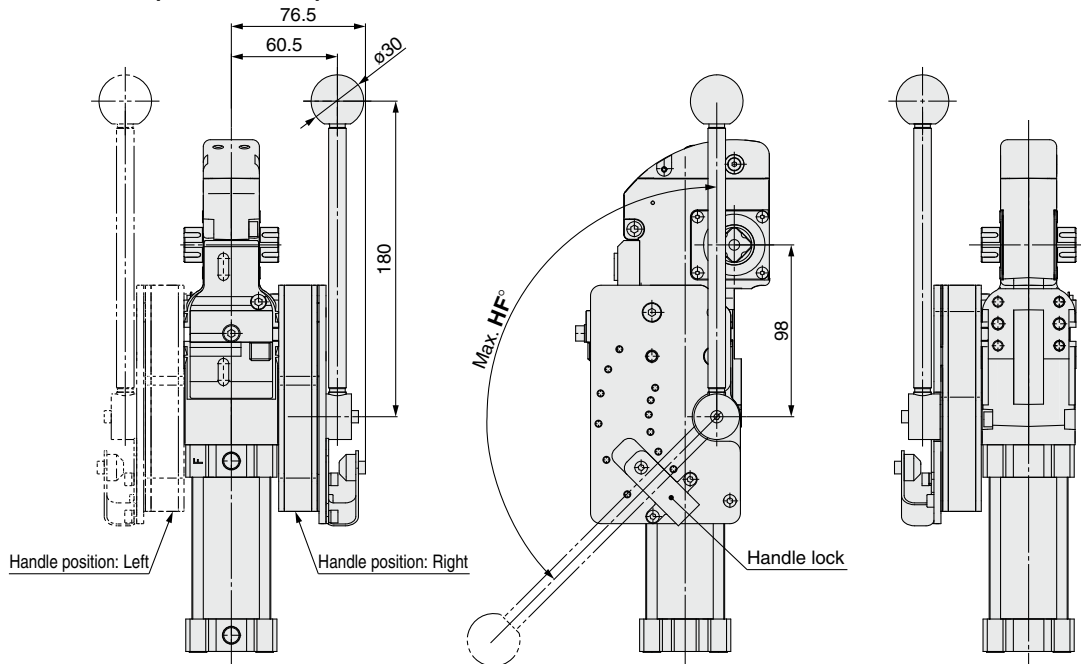

[mm]		
Bore size	Arm opening angle [°]	HF°
40	30	43
	45	54
	60	66
	75	81
	90	99
	105	119
	120	135

**Dimensions: Clamp Arm**

**Offset 15**

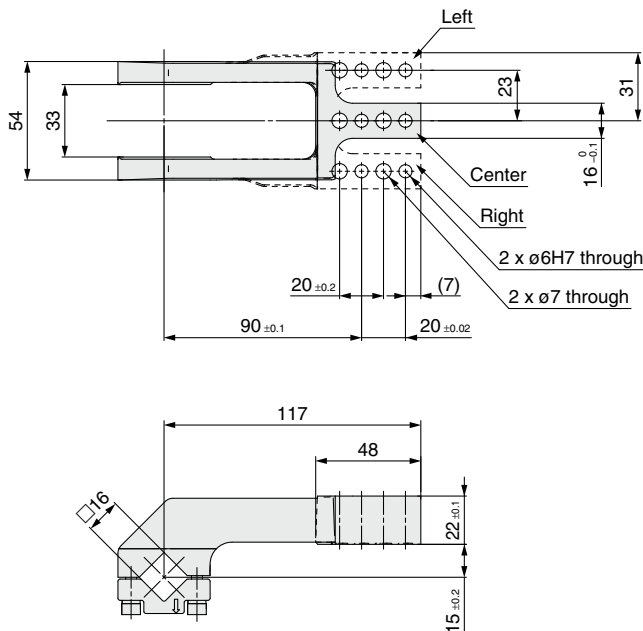

**How to Order**

**CKZT40 – A015 C S**

Arm position ●

<b>C</b>	Center
<b>R</b>	Right
<b>L</b>	Left

**Weight**

<b>CKZT40-A015CS</b>	0.49 kg
<b>CKZT40-A015RS</b>	0.51 kg
<b>CKZT40-A015LS</b>	0.51 kg

**Offset 45**

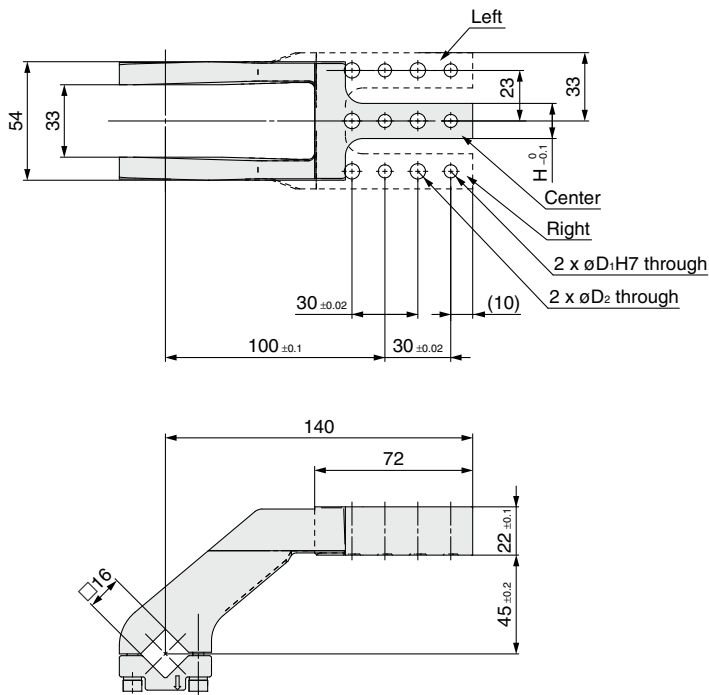

**How to Order**

**CKZT40 – A045 C S**

Arm position ●

<b>C</b>	Center
<b>R</b>	Right
<b>L</b>	Left

Mounting hole ●

Symbol	D <sub>1</sub>	D <sub>2</sub>	H
<b>S</b>	6	7	16
<b>B</b>	8	10.2	20

**Weight**

<b>CKZT40-A045CS</b>	0.63 kg
<b>CKZT40-A045CB</b>	0.64 kg
<b>CKZT40-A045RS</b>	0.64 kg
<b>CKZT40-A045RB</b>	0.66 kg
<b>CKZT40-A045LS</b>	0.64 kg
<b>CKZT40-A045LB</b>	0.66 kg

Power Clamp Cylinders	CKZM16
	CKZT25/32
	CKZT40
	CKZ3T
Power Clamp Cylinders	CKZT80
	CKZ3N
	CKZ2N
Related Products	C(L)KQG□ C(L)KQP□
	C(L)KQ□D -X3256
	C(L)KQG32 C(L)KU32
	C(L)KQG32 -X3036
Flow Control Equipment	
Piping Equipment	

# CKZT Series Model Selection

## Relation between arm length and clamping force

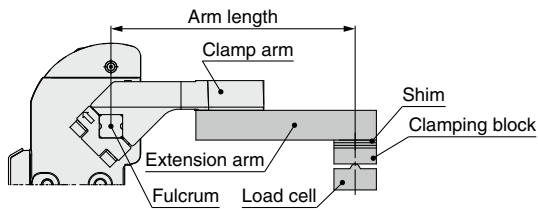

### Bore Size: 40

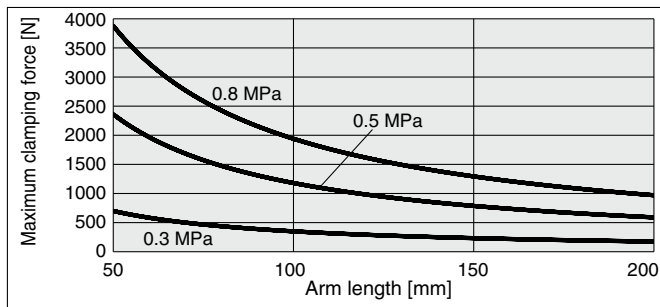

## Allowable arm length

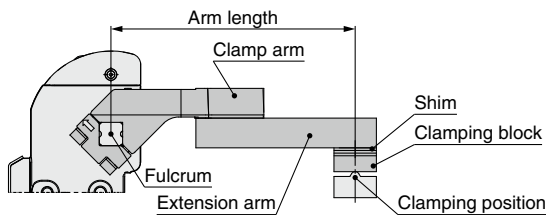

Bore size	Allowable arm length [mm]
40	200

## Allowable load mass

The allowable load mass changes depending on the arm opening angle.  
Be sure to use the product within the allowable values shown in the graph below.  
\* The load indicates the total weight of the clamp arm, extension arm, and clamping block.  
\* When the operating time is 1 second

### Calculation procedure for allowable load mass

1. Calculate the distance  $L$  from the fulcrum to the load center of gravity.
2. Check the arm opening angle of the product.
3. Read the allowable load mass from the graph.

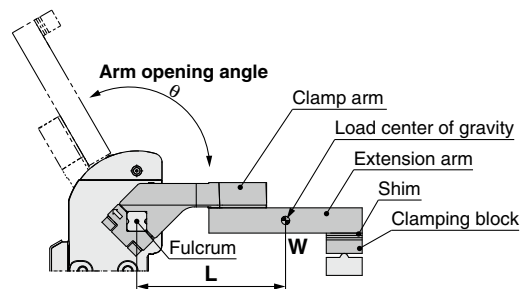

### Bore Size: 40

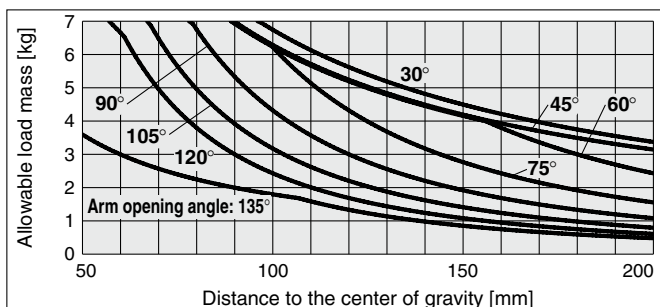



# CKZT Series Setup Procedure

## Precautions

- 1) The tightening torque of the clamp arm is 6.0 to 9.0 N·m for  $\phi 40$ . Refer to page 32 for details on the clamp arm.
- 2) There is a mechanical difference of 0 to  $+0.5^\circ$  at the clamping end as shown in Figure 1. Be sure to make adjustments externally using a shim. Refer to page 36.
- 3) Be sure to use a speed controller, and make adjustments according to the following conditions.

**Unclamping to clamping: 1 second or more**

**Clamping to unclamping: 1 second or more**

If excessive kinetic energy is applied, there is a possibility of damage.

- 4) When using a side guide: Attach the side guide so that lateral loads, such as galling, etc., are not applied to the clamp arm.

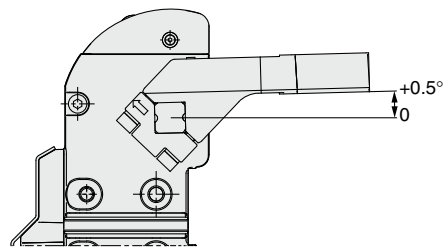
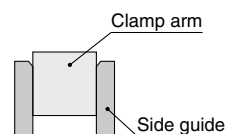
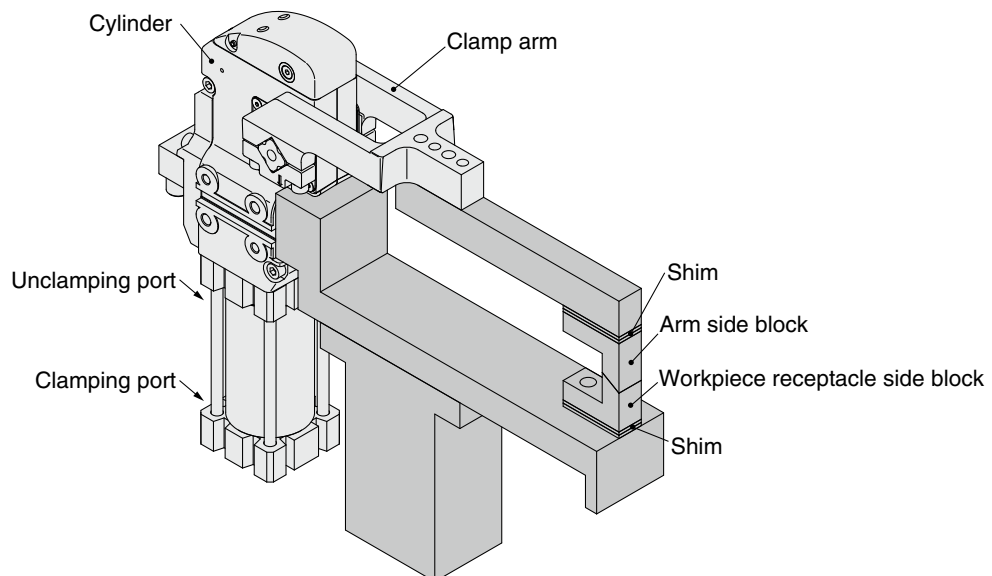

Figure 1



## Power clamp cylinder mounting and setup procedure

<Ex. 1 When using clamping force only: When equipped with a workpiece receptacle>



### Procedure

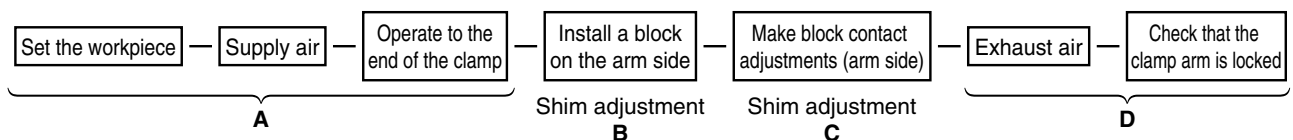

- A) Place the workpiece, supply air to the clamping port without attaching the block on the arm side, and operate the clamp arm to the end of the clamp.
- B) In the state of A), attach the workpiece and the arm side block, and adjust the shim so that there is a space of about 0 mm. During this step, theoretically, there is no clamping force pressing down on the workpiece.
- C) In order to generate a clamping force from the state described in step B), insert an additional shim. The thickness of the shim changes depending on the arm length and the operating pressure. Refer to page 36. Please note that the graph should only be used as a guide as there is a tolerance of about 10% in the clamp cylinder body.
- D) Exhaust the air while in the clamped state, and confirm that the clamp arm does not open.

Power Clamp Cylinders	CKZM16
	CKZT25/32
	CKZT40
	CKZ3T
Related Products	CKZT80
	CKZ3N
	CKZ2N
Flow Control Equipment	C(L)KQG□ C(L)KQP□
	C(L)KQ□D -X3256
	C(L)KQG32 C(L)KU32
	C(L)KQG32 -X3036
Piping Equipment	

## Power clamp cylinder mounting and setup procedure

### <Ex. 2 When using a hard stop: When not equipped with a workpiece receptacle>

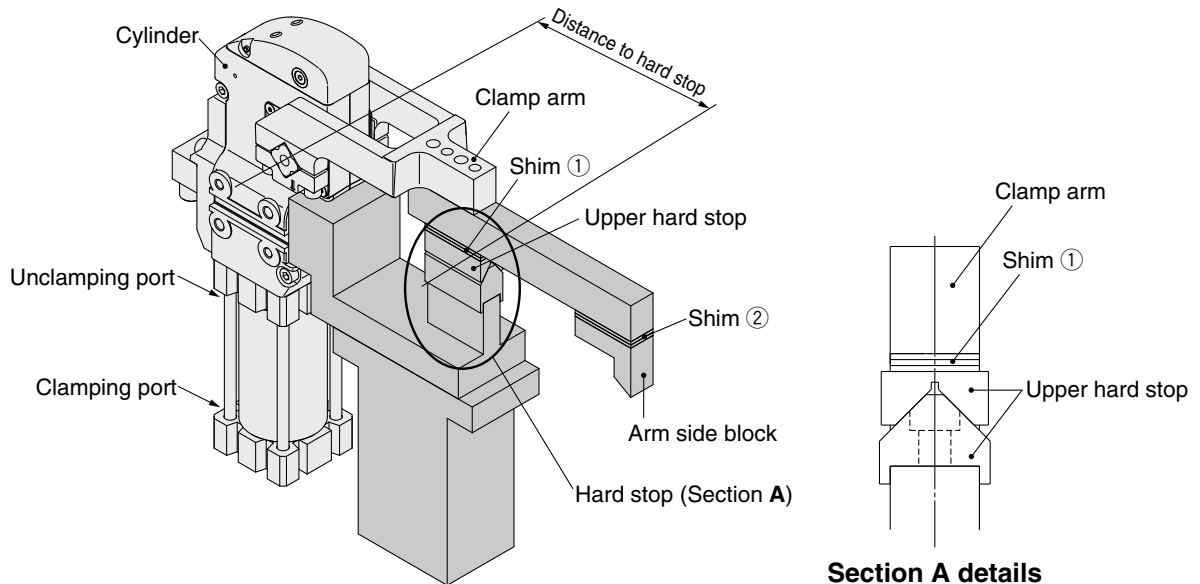

#### ■ Procedure

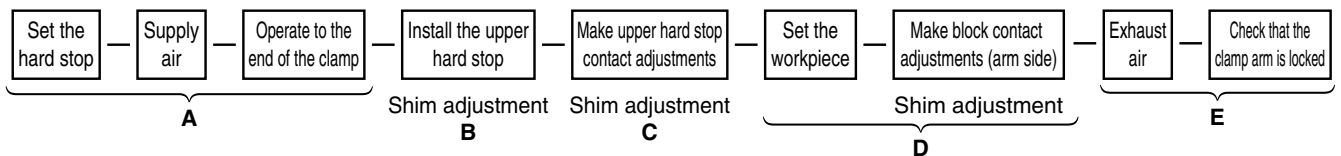

- A) Supply air to the clamping port without installing the upper hard stop, and operate the clamp arm to the end of the clamp.
- B) In the state of A), attach the upper hard stop and adjust shim ① so that there is a space of about 0 mm between the upper hard stop and the hard stop.  
During this step, theoretically, there is no clamping force applied to the hard stop.
- C) In order to generate a clamping force from the state described in step B), insert an additional shim.  
The thickness of the shim changes depending on the distance to the hard stop and the operating pressure. Refer to page 36, and consider the distance to the hard stop as the arm length.  
Please note that the graph should only be used as a guide as there is a tolerance of about 10% in the clamp cylinder body.
- D) In the state of C), adjust shim ② so that the arm side block contacts the workpiece.
- E) Exhaust the air while in the clamped state, and confirm that the clamp arm does not open.

## Relation between shim thickness and clamping force

- \* Use this figure as a guide as there is a tolerance of about 10% in the clamp cylinder body.
- \* When a shim exceeding the peak clamping force position on the graph is inserted, the lock will not be activated when clamped. Insert a shim of the appropriate thickness.
- \*1 The arm length indicates the distance between the clamp arm shaft and the clamping position.

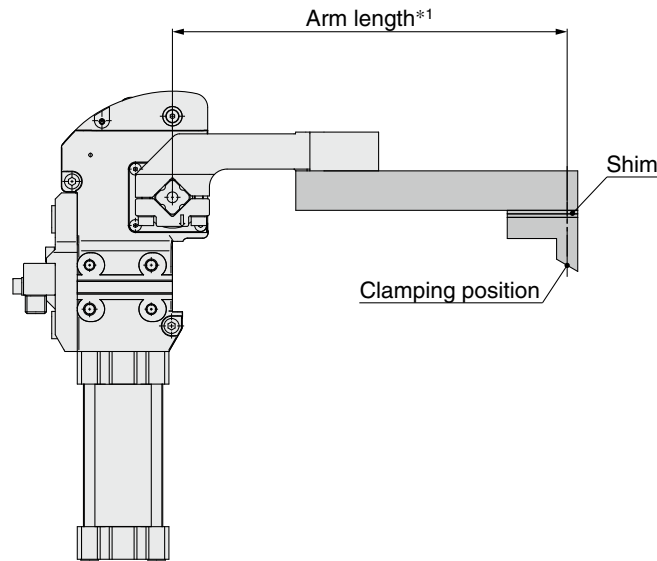

### Bore Size: 40

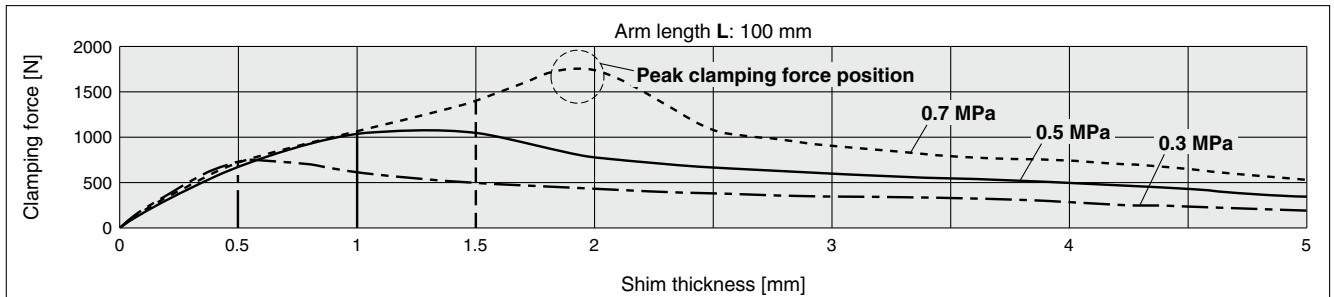

CKZM16

CKZT25/32

CKZT40

CKZ3T

CKZT80

CKZ3N

CKZ2N

C(L)KQG□  
C(L)KQP□

C(L)KQ□D  
-X3256

C(L)KQG32  
C(L)KU32

C(L)KQG32  
-X3036

Flow Control  
Equipment

Piping  
Equipment

## To change the arm opening angle

**⚠ Caution** Be sure to confirm safety, and perform the work while the air is exhausted.

### Procedure for changing the arm opening angle

1) When changing the arm opening angle, be sure to confirm that the air inside the cylinder has been exhausted.

2) Remove the switch cassette.

\* 8 types of arm opening angles (unclamping angles) 30°, 45°, 60°, 75°, 90°, 105°, 120°, and 135° are available for each standard size.

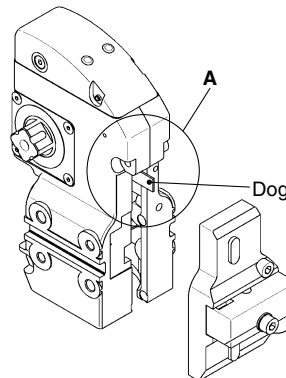

3) Remove the dog of the A part, and mount a different dog for other angles using the tightening torque below. (Confirm the direction of the angle display.) Then mount the switch cassette using the tightening torque below.

Description	Bore size [mm]	Tightening torque
		N·m
Dog	40	3.0 to 4.0
Switch cassette	40	3.0 to 4.0

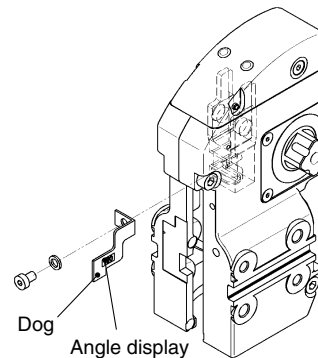

4) Remove the stopper bolt of the head cover, and mount a different stopper bolt for other angles using the tightening torque below. (Confirm the angle display.)

Description	Bore size [mm]	Tightening torque
		N·m
Stopper bolt	40	12.5 to 16.3

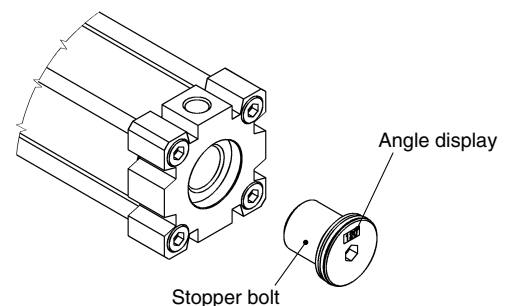

## Top cover replacement

**⚠ Caution** Be sure to confirm safety, and perform the work while the air is exhausted.

1) Mount the top cover to the clamp cylinder, then tighten it to the specified tightening torque below.

\* It is not possible to change between cover materials afterward (rubber cover type/metal cover type).

\* Refer to Replacement Parts (page 29) for the part numbers of the top cover replacement parts.

### Top Cover Mounting Bolt Tightening Torque

Bore size	Tightening torque [N·m]
40	1.5 to 2.0

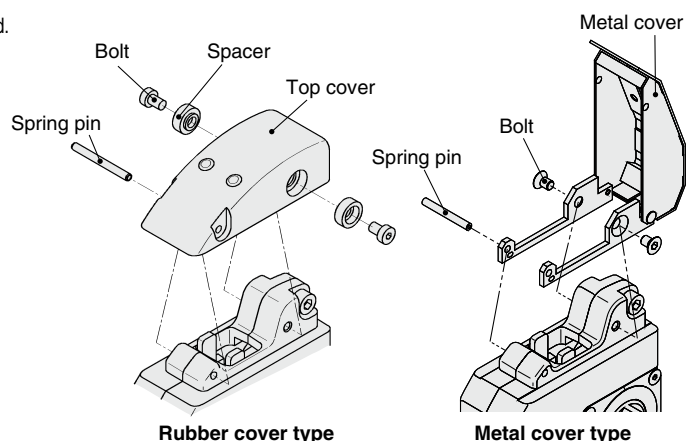



# CKZT Series Specific Product Precautions

Be sure to read this before handling the products. Refer to page 151 for safety instructions. For actuator precautions, refer to the “Handling Precautions for SMC Products” and the “Operation Manual” on the SMC website: <https://www.smcworld.com>

## ⚠ Caution

### 1. Manual lock release

Be sure to confirm safety before manually releasing the lock, and only perform work **while the air is exhausted**. Otherwise, the clamp arm may operate unexpectedly.

- In the case of a rubber cover, the lock can be released easily by hitting the round tab on the cover with a plastic hammer.
- In the case of a metal cover, the lock can be released easily by opening the cover and hitting the tab of the knuckle joint with a plastic hammer.

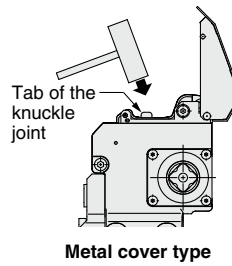
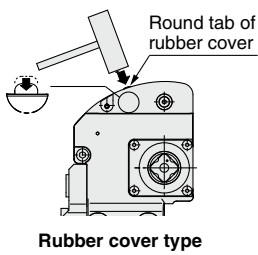

- Provide enough space to perform a manual lock release.

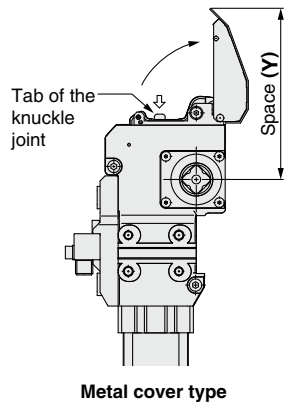
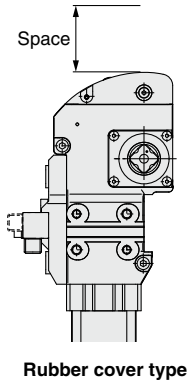

Bore size	Y [mm]
40	118.3

## ⚠ Caution

### 2. Do not disassemble the power clamp cylinder.

The power clamp cylinder consists of a completely sealed structure in order to protect it from welding spatter. Do not disassemble, except for when replacing any of the replaceable parts, as this may cause the performance to deteriorate.

### 3. Vertical clamping

When mounting the clamp arm in a vertical clamping position, mount as shown in the figure below. The maximum arm opening angle is 105° for offset 15 and 120° for offset 45 (mounting hole symbol B). In the case of a metal cover type, select a 45 mm offset for the clamp arm. When a 15 mm offset is selected, the metal cover and clamp arm will interfere and the lock cannot be released manually.

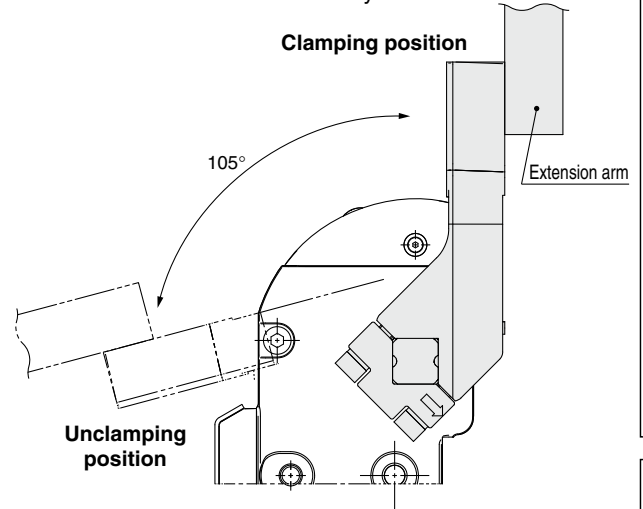

### 4. Proximity switch output

The switch output signal is output near the clamping end and the unclamping end respectively. The switch output signal on the clamping side does not output the status where the power clamp cylinder is locked by the toggle mechanism.

### 5. With manually operated handle

Operating force of the handle should be 150 N or less. Excessive forces applied to the handle will lead to breakage or deformation.

### 6. Operating time and allowable load mass

Fast operation (short stroke times) or excessive loads will lead to the breakage or deformation of the product. It is recommended to install shock absorbers to reduce impact force in these instances.

CKZM16

CKZT25/32

CKZT40

CKZ3T

CKZT80

CKZ3N

CKZ2N

C(L)KQG□  
C(L)KQP□

C(L)KQ□D  
-X3256

C(L)KQG32  
C(L)KU32

C(L)KQG32  
-X3036

Flow Control  
Equipment

Piping  
Equipment

Power Clamp Cylinders

Related Products