

Power Clamp Cylinder

CKZT Series

ø80

High clamping force

Clamping force: **8800 N**

(Arm length: 100 mm, 0.5 MPa pressure)

Force amplification with a toggle mechanism and lock function

Can hold a clamped state when supply pressure drops or residual pressure is released

Spatter-proof construction

Fully closed structure prevents the intrusion of spatter

Equipped with a proximity switch that can be used in welding magnetic fields

A model with a manually operated handle (lock specification) is available.

- For manual workpiece setting processes
- The handle is held at unclamped position.



CKZM16

CKZT25/32

CKZT40

CKZ3T

CKZT80

CKZ3N

CKZ2N

Power Clamp Cylinders

Related Products

C(L)KQG□
C(L)KQP□

C(L)KQ□D
-X3256

C(L)KQG32
C(L)KU32

C(L)KQG32
-X3036

Flow Control
Equipment

Piping
Equipment

Power Clamp Cylinder

CKZT Series

ø80



How to Order

Base type

CKZT 80 **TN** - **120** **T**

With manually operated handle

CKZT 80 **TN** - **105** **T** - X2568 **L**

Cylinder port

Nil	G
TN	NPT

Bore size

Arm opening angle

Symbol	Base type	With manually operated handle X2568
30	○	○
45	○	○
60	○	○
75	○	○
90	○	○
105	○	○
120	○	—
135	○	—

Proximity switch

T	TURCK
P	P&F

Manually operated handle mounting position

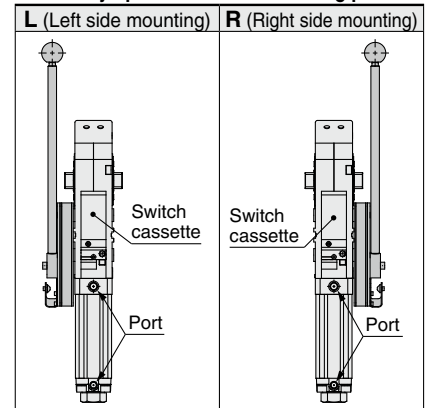

* Switch cassette viewed from the front

Clamp arm

CKZT 80 - **A015** **C** **S**

Bore size

Offset

A015	Offset 20
A045	Offset 45

Mounting hole

Symbol	Bore size	D ₁	D ₂
S	80	6	9
B	80	8	10.2

Arm position

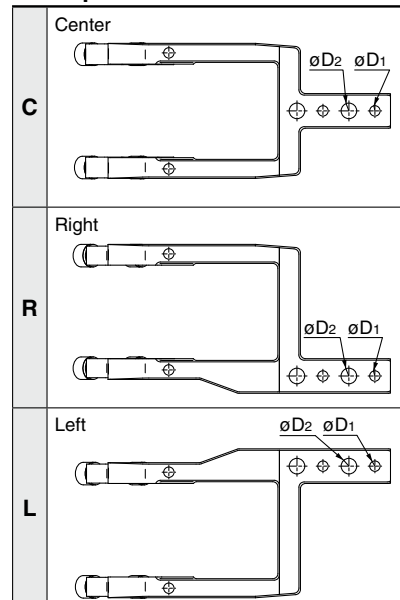

Cylinder Specifications

Bore size [mm]	80
Action	Double acting
Fluid	Air
Proof pressure	1.2 MPa
Max. operating pressure	0.8 MPa
Min. operating pressure	0.3 MPa
Ambient and fluid temperatures	-10 to 60°C
Cushion	Clamping side: None Unclamping side: Rubber bumper
Operating time	Clamping: 1 s or more, Unclamping: 1 s or more
Max. allowable holding moment*1	2500 N·m

*1 Refer to the maximum holding force (torque) while clamped with the operating air exhausted.
This is not the possible holding force (torque) for normal use.

Weight (Cylinder Without Arm)

Bore size [mm]	Arm opening angle							Extra weight is due to addition of the manually operated handle	
	30°	45°	60°	75°	90°	105°	120°		135°
80	17.2	17.1	17.1	17.0	16.9	16.9	16.8	16.8	3.9

Cylinder Stroke

Bore size	Angle							
	30°	45°	60°	75°	90°	105°	120°	135°
80	47.3	59.4	71.1	83.2	95.7	108.0	119.1	127.3

Proximity Switch Specifications

Manufacturer	TURCK	P&F
Power supply voltage	10 to 30 VDC	10 to 30 VDC
Output	N.O., PNP	N.O., PNP
Continuous load current	150 mA	100 mA
Response frequency	30 Hz	25 Hz
Housing material	PBT	PA6, PBT
Output indication	Clamping side: Red Unclamping side: Yellow	Clamping side: Red Unclamping side: Yellow
Power supply indication	Green	Green
Connector	M12 connector	M12 connector

* Switch specifications correspond to the manufacturers' technical information.

Wiring Diagram (PNP Connection Circuit)

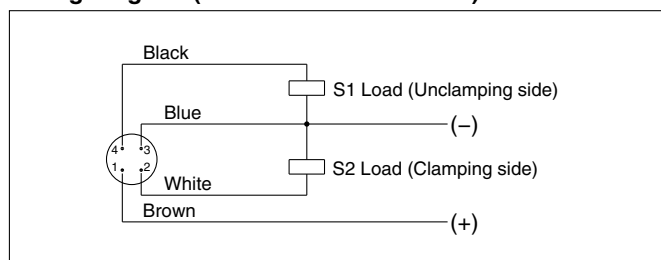

* Applicable to both TURCK and P&F
* Please contact SMC for NPN specifications.

Power Clamp Cylinders
CKZM16
CKZT25/32
CKZT40
CKZ3T
CKZT80
CKZ3N
CKZ2N

Related Products
C(L)KQG□
C(L)KQP□
C(L)KQ□D
-X3256
C(L)KQG32
C(L)KU32
C(L)KQG32
-X3036
Flow Control Equipment
Piping Equipment

CKZT Series

Replacement Parts

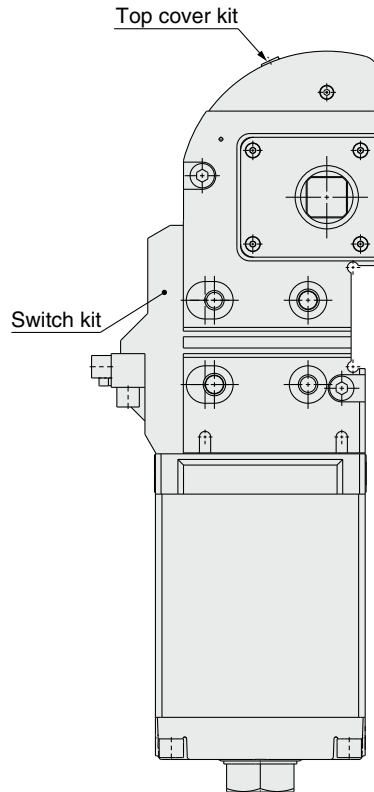

Switch Kit No.

CKZ1N - S 080 T

● Bore size

● Proximity switch

T	TURCK
P	P&F

* The switch kit includes a switch holder, proximity switch, and mounting brackets.

Top Cover Kit No.

Rubber cover

CKZ2N - T 080

● Bore size

* The top cover kit includes a top cover and mounting brackets.
* Refer to page 65 for the procedure for changing the arm opening angle and top cover replacement instructions.

Kit No. for Changing the Arm Opening Angle (For details, refer to page 65.)

CKZN - B 080 D

● Kit type

B	Stopper bolt kit
D	Dog kit
K	A set of B and D

● Bore size

● Arm opening angle

H	30°
G	45°
F	60°
E	75°
D	90°
C	105°
B	120°
A	135°

* The stopper bolt kit includes a stopper bolt and mounting brackets.
* The dog kit includes a dog and mounting brackets.

Dimensions

CKZT80

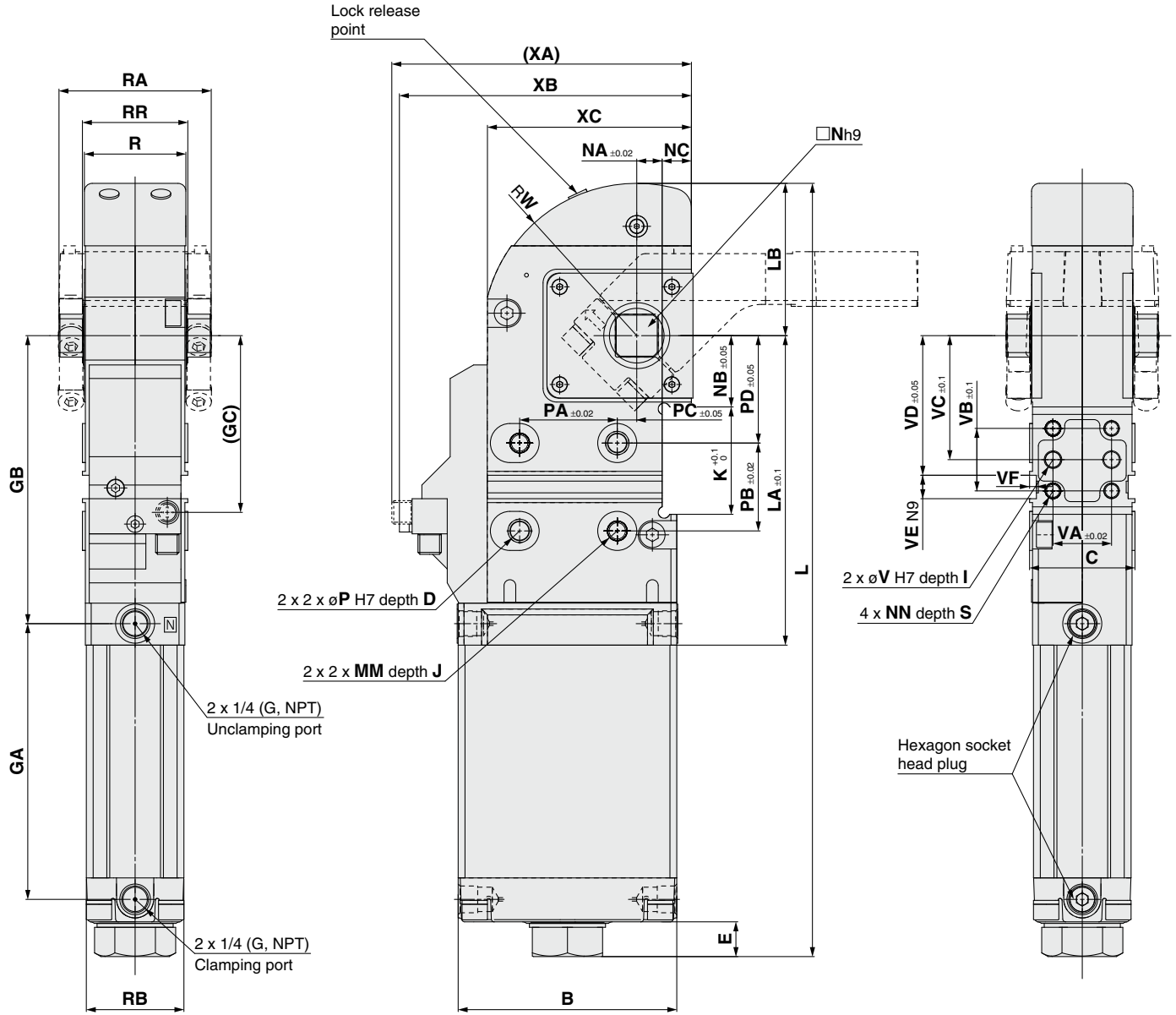

Bore size [mm]	B	C	D	E	GA	GB	GC	I	J	K	L	LA	LB	MM	N	NA	NB	NC	NN	P
80	154	76	13	19.6	185.8	199	137.5	12	18	80	530.9	214	113.7	M12 x 1.75	30	21	50	20.8	M10 x 1.5	12

Bore size [mm]	PA	PB	PC	PD	R	RA	RB	RR	S	V	VA	VB	VC	VD	VE	VF	W	XA	XB	XC
80	70	75	15	65	70	108	68	76	15	8	50	50	90	96.5	12	3.5	113.7	197.3	192.8	148.3

Power Clamp Cylinders	CKZM16
	CKZT25/32
	CKZT40
	CKZ3T
	CKZT80
	CKZ3N
	CKZ2N
Related Products	C(L)KQG□ C(L)KQP□
	C(L)KQ□D -X3256
	C(L)KQG32 C(L)KU32
	C(L)KQG32 -X3036
Flow Control Equipment	
Piping Equipment	

CKZT Series

Dimensions: With Manually Operated Handle

* Refer to the CKZT80 (page 58) for dimensions other than those shown below.

CKZT80-□-X2568^L_R

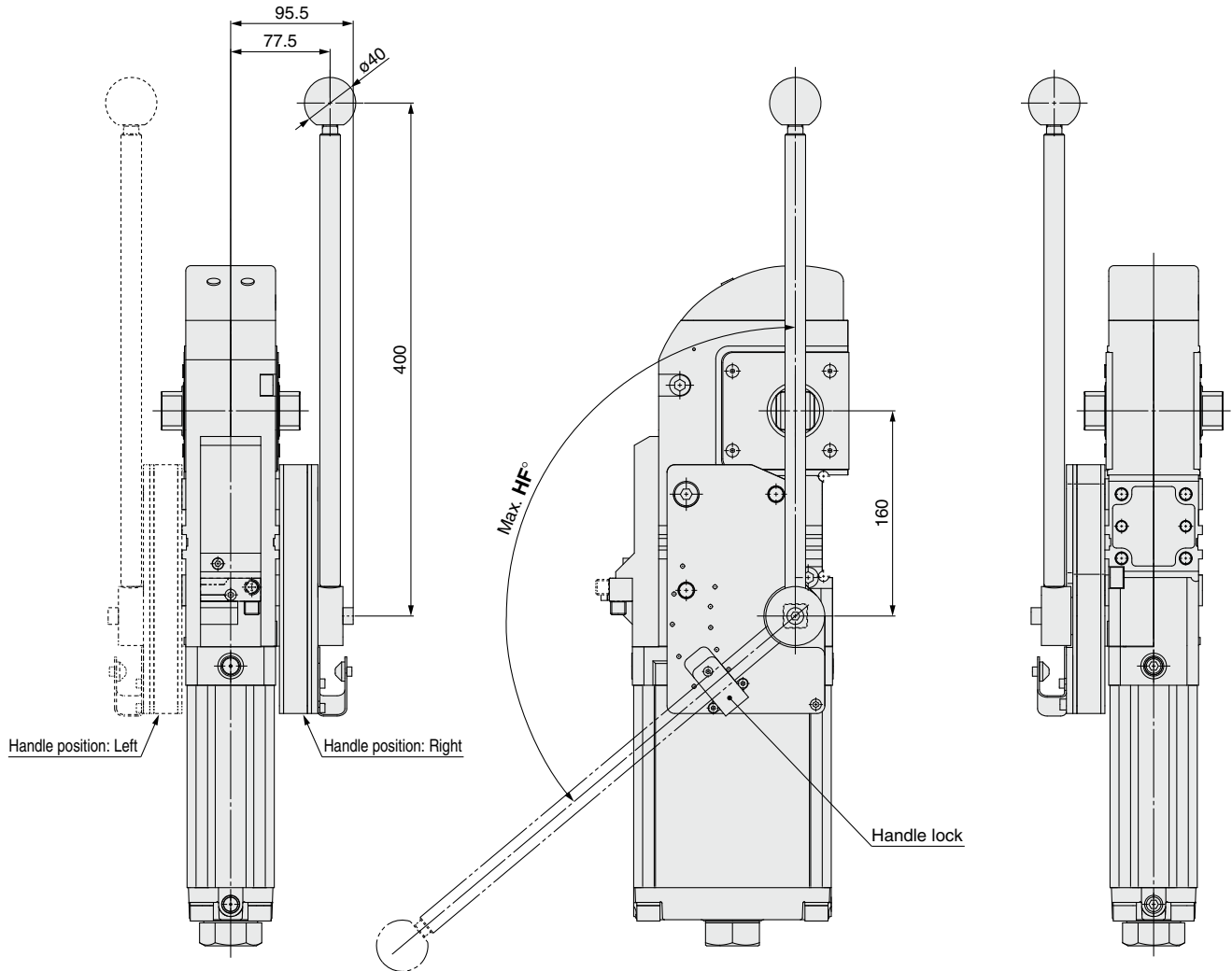

[mm]		
Bore size	Arm opening angle [°]	HF°
80	30	57
	45	71
	60	85
	75	101
	90	116
	105	130

Dimensions: Clamp Arm

Offset 20

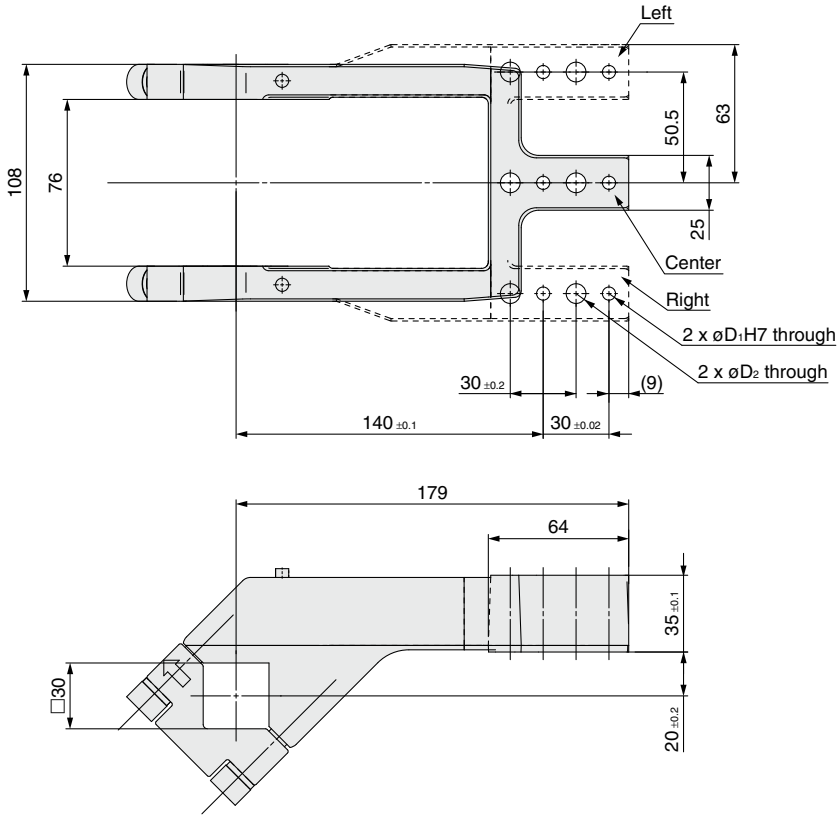

How to Order

CKZT80 – A015 C S

Arm position ●

C	Center
R	Right
L	Left

Mounting hole ●

Symbol	D1	D2
S	6	9
B	8	10.2

Weight

CKZT80-A015CS	2.17 kg
CKZT80-A015CB	2.16 kg
CKZT80-A015RS	2.21 kg
CKZT80-A015RB	2.19 kg
CKZT80-A015LS	2.21 kg
CKZT80-A015LB	2.19 kg

Offset 45

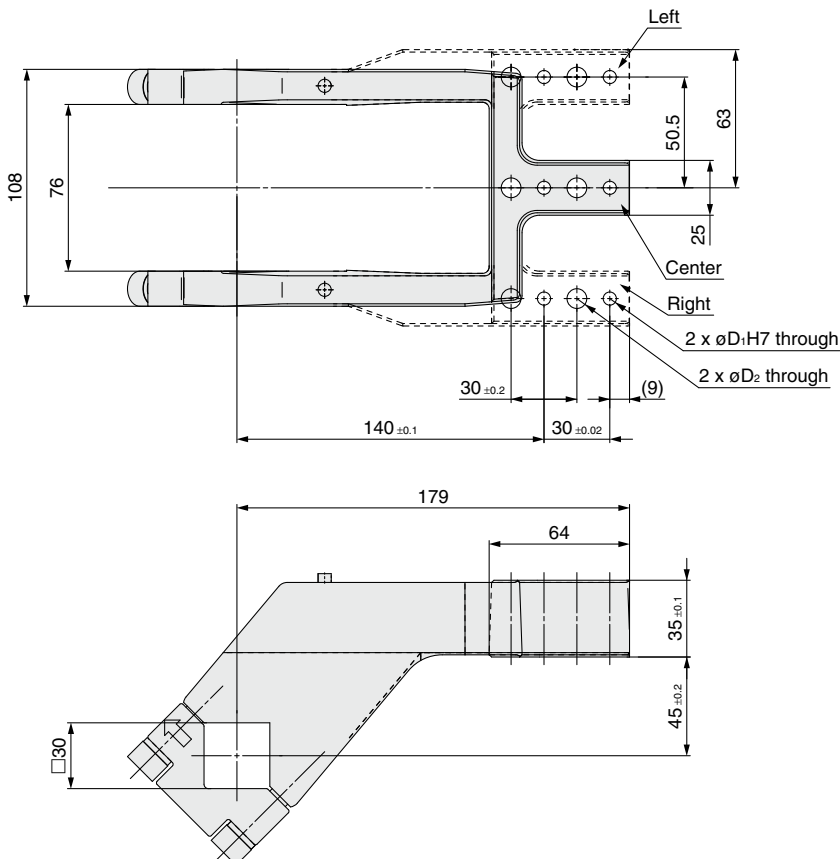

How to Order

CKZT80 – A045 C S

Arm position ●

C	Center
R	Right
L	Left

Mounting hole ●

Symbol	D1	D2
S	6	9
B	8	10.2

Weight

CKZT80-A045CS	2.46 kg
CKZT80-A045CB	2.44 kg
CKZT80-A045RS	2.61 kg
CKZT80-A045RB	2.59 kg
CKZT80-A045LS	2.61 kg
CKZT80-A045LB	2.59 kg

Power Clamp Cylinders	CKZM16
	CKZT25/32
	CKZT40
	CKZ3T
	CKZT80
	CKZ3N
	CKZ2N
Related Products	C(L)KQG□ C(L)KQP□
	C(L)KQ□D -X3256
	C(L)KQG32 C(L)KU32
	C(L)KQG32 -X3036
Flow Control Equipment	
Piping Equipment	

CKZT Series Model Selection

Relation between arm length and clamping force

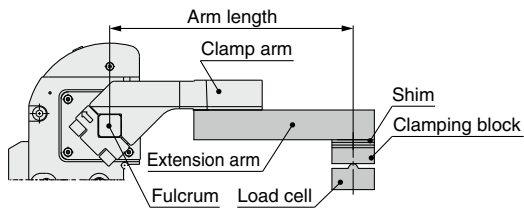

Bore Size: 80

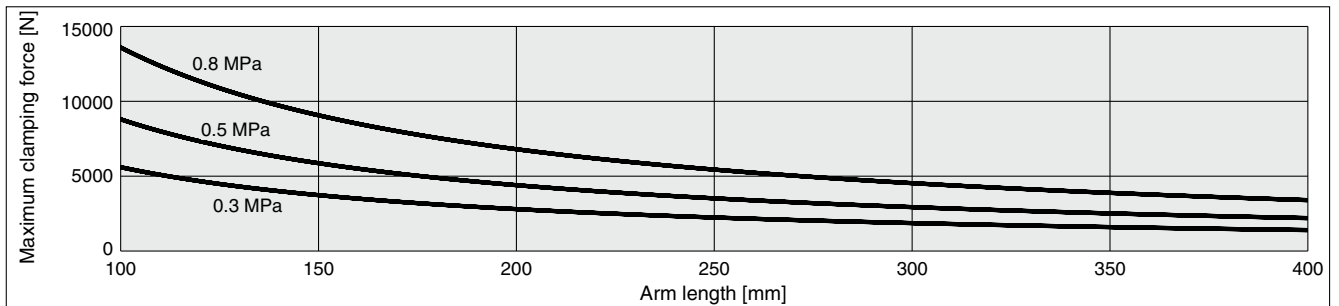

Allowable arm length

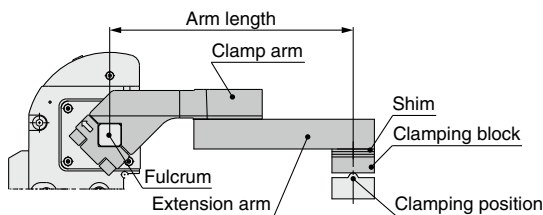

Bore size	Allowable arm length [mm]
80	400

Allowable load mass

The allowable load mass changes depending on the arm opening angle. Be sure to use the product within the allowable values shown in the graph below.
 * The load indicates the total weight of the clamp arm, extension arm, and clamping block.
 * When the operating time is 1 second

Calculation procedure for allowable load mass

1. Calculate the distance L from the fulcrum to the load center of gravity.
2. Check the arm opening angle of the product.
3. Read the allowable load mass from the graph.

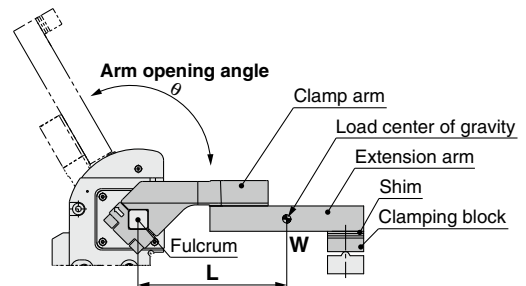

Bore Size: 80

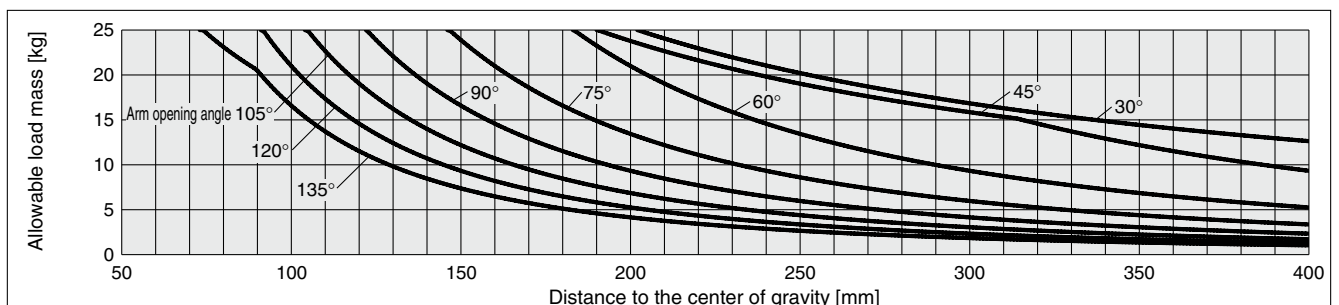

CKZT Series Setup Procedure

Precautions

- 1) The tightening torque of the clamp arm is 18 to 24 N·m for $\phi 80$. Refer to page 60 for details on the clamp arm.
- 2) There is a mechanical difference of 0 to $+0.5^\circ$ at the clamping end as shown in Figure 1. Be sure to make adjustments externally using a shim. Refer to page 64.
- 3) Be sure to use a speed controller, and make adjustments according to the following conditions.

Unclamping to clamping: 1 second or more

Clamping to unclamping: 1 second or more

If excessive kinetic energy is applied, there is a possibility of damage.

- 4) When using a side guide: Attach the side guide so that lateral loads, such as galling, etc., are not applied to the clamp arm.

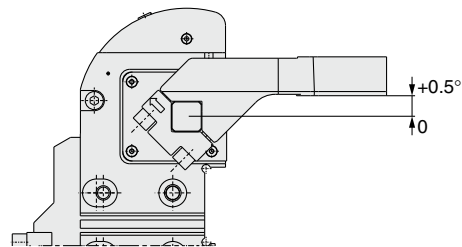
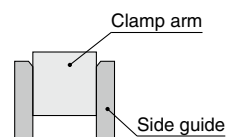
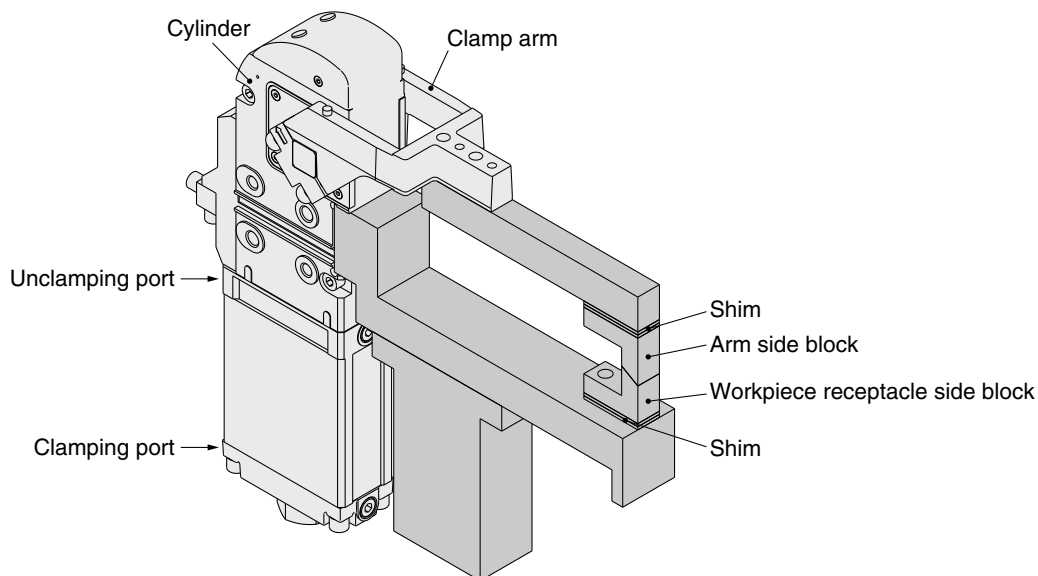

Figure 1



Power clamp cylinder mounting and setup procedure

<Ex. 1 When using clamping force only: When equipped with a workpiece receptacle>



Procedure

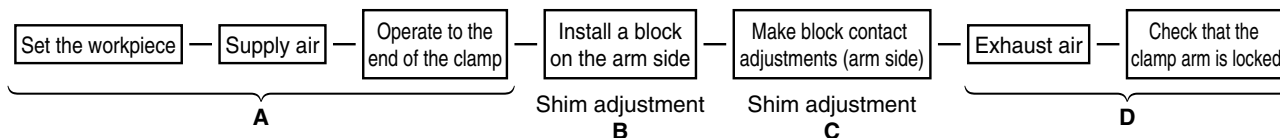

- A) Place the workpiece, supply air to the clamping port without attaching the block on the arm side, and operate the clamp arm to the end of the clamp.
- B) In the state of A), attach the workpiece and the arm side block, and adjust the shim so that there is a space of about 0 mm. During this step, theoretically, there is no clamping force pressing down on the workpiece.
- C) In order to generate a clamping force from the state described in step B), insert an additional shim. The thickness of the shim changes depending on the arm length and the operating pressure. Refer to page 64. Please note that the graph should only be used as a guide as there is a tolerance of about 10% in the clamp cylinder body.
- D) Exhaust the air while in the clamped state, and confirm that the clamp arm does not open.

CKZM16

CKZT25/32

CKZT40

Power Clamp Cylinders

CKZ3T

CKZT80

CKZ3N

CKZ2N

C(L)KQG□
C(L)KQP□

C(L)KQ□D
-X3256

C(L)KQG32
C(L)KU32

Related Products

C(L)KQG32
-X3036

Flow Control
Equipment

Piping
Equipment

Power clamp cylinder mounting and setup procedure

<Ex. 2 When using a hard stop: When not equipped with a workpiece receptacle>

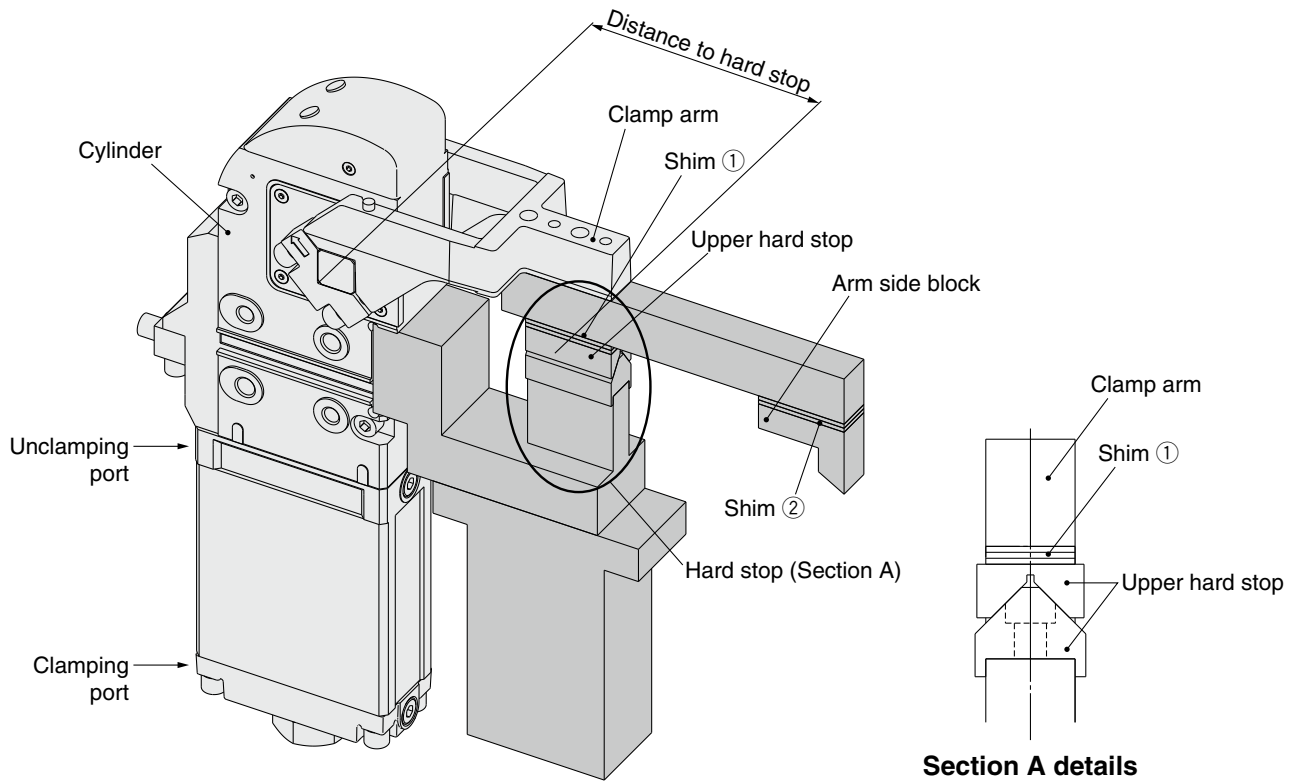

Procedure

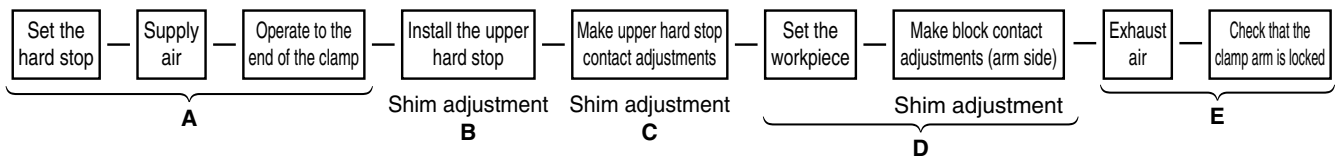

A) Supply air to the clamping port without installing the upper hard stop, and operate the clamp arm to the end of the clamp.

B) In the state of A), attach the upper hard stop and adjust shim ① so that there is a space of about 0 mm between the upper hard stop and the hard stop.

During this step, theoretically, there is no clamping force applied to the hard stop.

C) In order to generate a clamping force from the state described in step B), insert an additional shim.

The thickness of the shim changes depending on the distance to the hard stop and the operating pressure. Refer to page 64, and consider the distance to the hard stop as the arm length.

Please note that the graph should only be used as a guide as there is a tolerance of about 10% in the clamp cylinder body.

D) In the state of C), adjust shim ② so that the arm side block contacts the workpiece.

E) Exhaust the air while in the clamped state, and confirm that the clamp arm does not open.

Relation between shim thickness and clamping force

- * Use this figure as a guide as there is a tolerance of about 10% in the clamp cylinder body.
- * When a shim exceeding the peak clamping force position on the graph is inserted, the lock will not be activated when clamped. Insert a shim of the appropriate thickness.
- *1 The arm length indicates the distance between the clamp arm shaft and the clamping position.

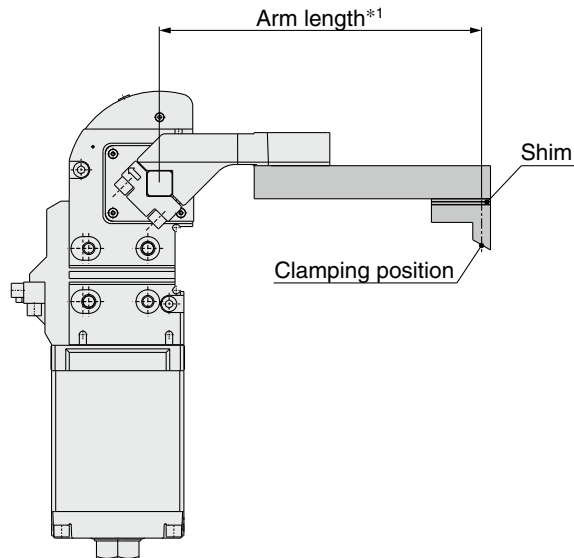

Bore Size: 80

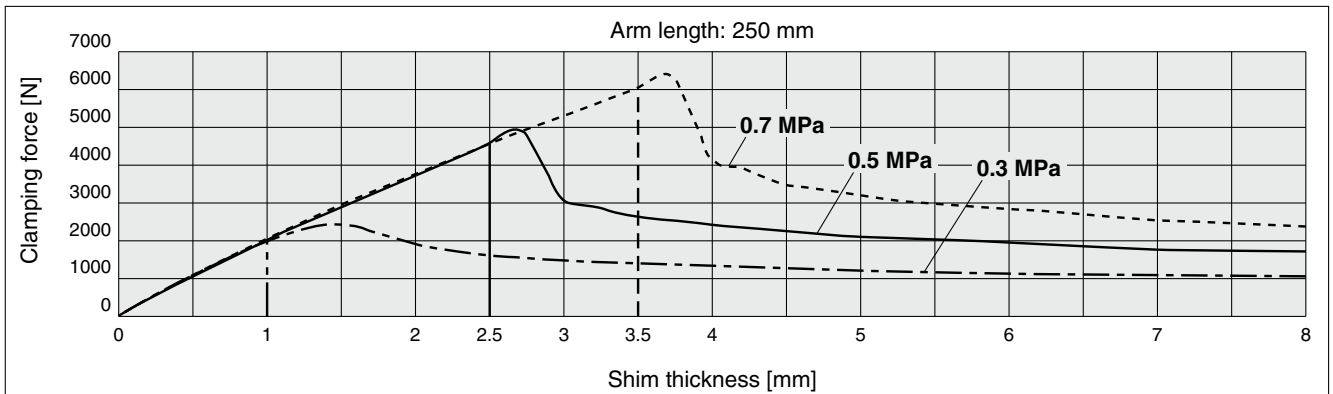

Power Clamp Cylinders	CKZM16
	CKZT25/32
	CKZT40
	CKZ3T
	CKZT80
CKZ3N	CKZ2N
	C(L)KQG□
	C(L)KQP□
Related Products	C(L)KQ□D
	C(L)KQG32
	C(L)KU32
Flow Control Equipment	C(L)KQG32-X3036
	C(L)KQ□D
Piping Equipment	C(L)KQ□D

To change the arm opening angle

⚠ Caution Be sure to confirm safety, and perform the work while the air is exhausted.

Procedure for changing the arm opening angle

- 1) When changing the arm opening angle, be sure to confirm that the air inside the cylinder has been exhausted.
 - 2) Remove the switch cassette.
- * 8 types of arm opening angles (unclamping angles) 30°, 45°, 60°, 75°, 90°, 105°, 120°, and 135° are available for each standard size.

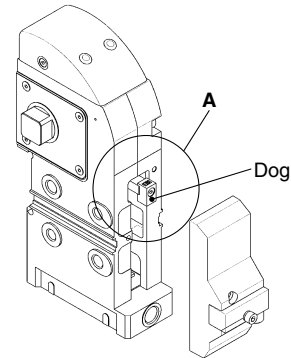

- 3) Remove the dog of the A part, and mount a different dog for other angles using the tightening torque below. (Confirm the direction of the angle display.) Then mount the switch cassette using the tightening torque below.

Description	Bore size [mm]	Tightening torque
		N·m
Dog	80	3.0 to 4.0
Switch cassette	80	5.0 to 7.0

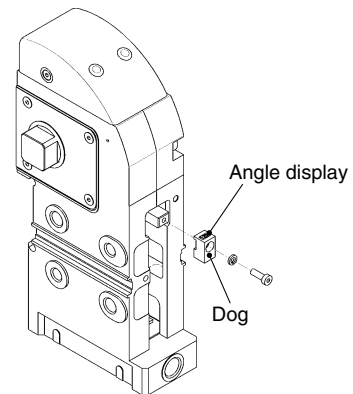

- 4) Remove the stopper bolt of the head cover, and mount a different stopper bolt for other angles using the tightening torque below. (Confirm the angle display.)

Description	Bore size [mm]	Tightening torque
		N·m
Stopper bolt	80	130 to 190

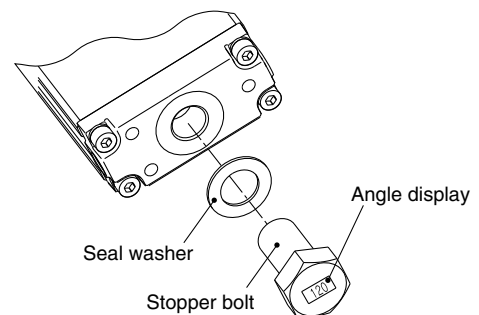

Top cover replacement

⚠ Caution Be sure to confirm safety, and perform the work while the air is exhausted.

- 1) Mount the top cover to the clamp cylinder, then tighten it to the specified tightening torque below.
- * Refer to Replacement Parts (page 57) for the part numbers of the top cover replacement parts.

Top Cover Mounting Bolt Tightening Torque

Bore size	Tightening torque [N·m]
80	3.0 to 5.0

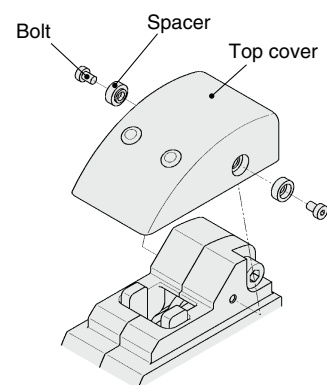

Rubber cover type



CKZT Series Specific Product Precautions

Be sure to read this before handling the products. Refer to page 151 for safety instructions. For actuator precautions, refer to the “Handling Precautions for SMC Products” and the “Operation Manual” on the SMC website: <https://www.smcworld.com>

⚠ Caution

1. Manual lock release

Be sure to confirm safety before manually releasing the lock, and only perform work **while the air is exhausted**. Otherwise, the clamp arm may operate unexpectedly.

- The lock can be released easily by hitting the round tab on the cover with a plastic hammer.

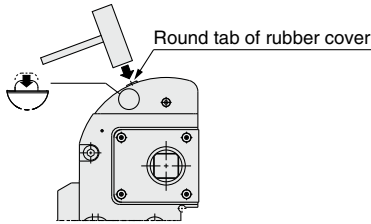

- Provide enough space to perform a manual lock release.

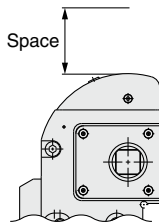

⚠ Caution

2. Do not disassemble the power clamp cylinder.

The power clamp cylinder consists of a completely sealed structure in order to protect it from welding spatter. Do not disassemble, except for when replacing any of the replaceable parts, as this may cause the performance to deteriorate.

3. Vertical clamping

When mounting the clamp arm in a vertical clamping position, mount as shown in the figure below. The maximum arm opening angle is 90° for offset 15 and 105° for offset 45.

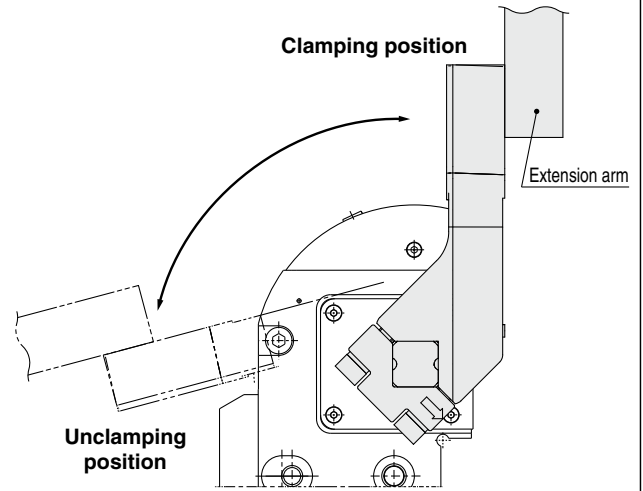

4. Proximity switch output

The switch output signal is output near the clamping end and the unclamping end respectively. The switch output signal on the clamping side does not output the status where the power clamp cylinder is locked by the toggle mechanism.

5. With manually operated handle

Operating force of the handle should be 200 N or less. Excessive forces applied to the handle will lead to breakage or deformation.

6. Operating time and allowable load mass

Fast operation (short stroke times) or excessive loads will lead to the breakage or deformation of the product. It is recommended to install shock absorbers to reduce impact force in these instances.

Power Clamp Cylinders	CKZM16
	CKZT25/32
	CKZT40
	CKZ3T
	CKZT80
Related Products	CKZ3N
	CKZ2N
	C(L)KQG□ C(L)KQP□
Flow Control Equipment	C(L)KQ□D -X3256
	C(L)KQG32 C(L)KU32
Piping Equipment	C(L)KQG32 -X3036