

Power Clamp Cylinder

Compact Type

CKZT -X2797, -X3064 (Base Type) / -X2798□, -X3174□ (With Manually Operated Handle)
 -X3232□, -X3229□ (With Manual Handle Lock)

ø25, ø32

For material handling and clamping of small workpieces

Lightweight Compact

High clamping force Lock function

Lightweight Weight : **580 g** (ø25, Rubber cover)

Compact Width : **34 mm**
 Height : **192.4 mm**
 (ø25, Arm opening angle: 90°, Rubber cover)

Clamping force : **1100 N**
 (ø32, Arm length: 50 mm, 0.5 MPa pressure)

Force amplification with a toggle mechanism and lock function

Can hold a clamped state when supply pressure drops or residual pressure is released

Spatter-proof construction

Fully closed structure prevents the intrusion of spatter

Equipped with a proximity switch that can be used in welding magnetic fields

A model with a manually operated handle is available.

For manual workpiece setting processes

Manual handle lock is available for small bore sizes.

The handle is held at unclamped position.

Selectable rubber or metal cover

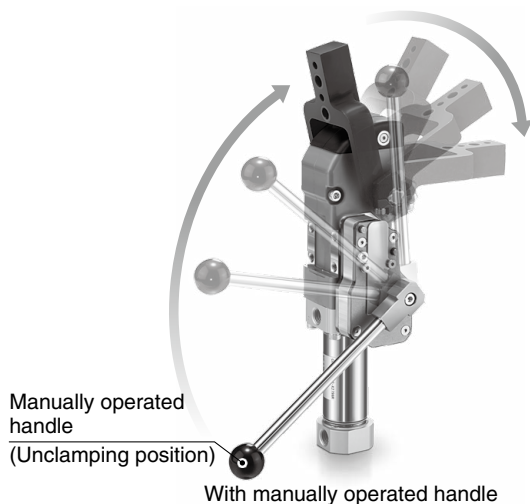
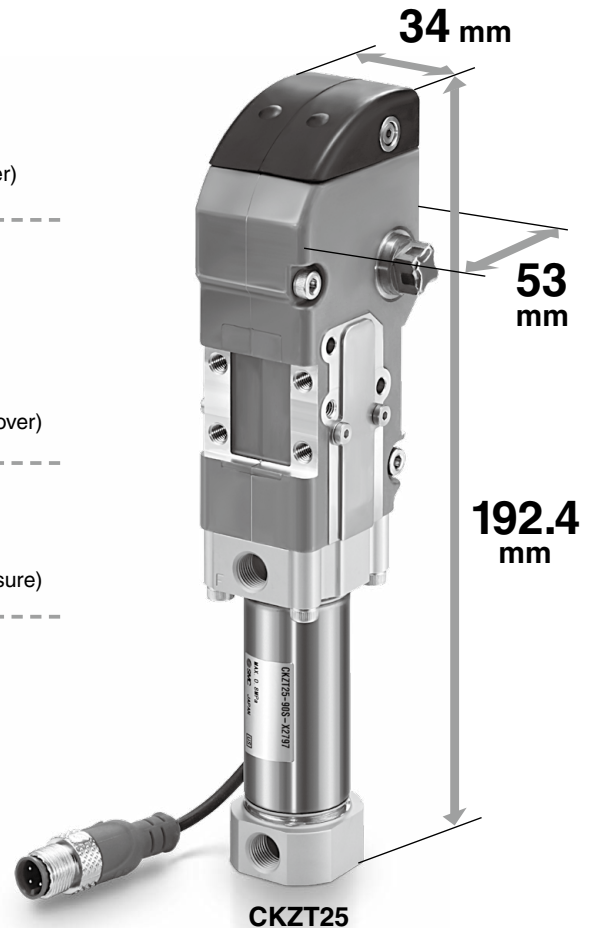

Power Clamp Cylinders	CKZM16
	CKZT25/32
	CKZT40
	CKZ3T
	CKZT80
Related Products	CKZ3N
	CKZ2N
	C(L)KQG□ C(L)KQP□
Flow Control Equipment	C(L)KQ□D -X3256
	C(L)KQG32 C(L)KU32
	C(L)KQG32 -X3036
Piping Equipment	

Power Clamp Cylinder Compact Type

CKZT

-X2797, -X3064
 -X2798□, -X3174□
 -X3232□, -X3229□
 ø25, ø32

How to Order

Base type

CKZT **25** - **105** S -

With manually operated handle

CKZT **25** - **105** S -

With manual handle lock

CKZT **25** - **105** S -

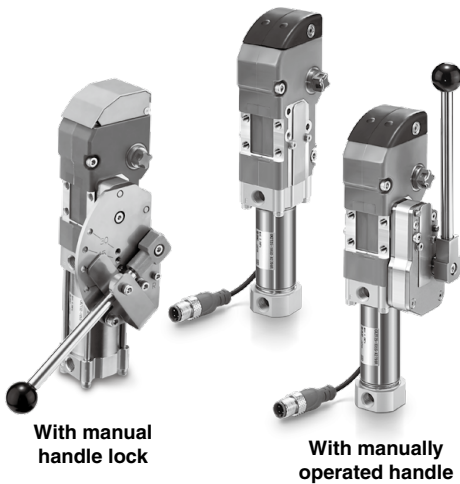

1 Bore size

25	25 mm
32	32 mm

2 Arm opening angle

90	90°
105	105°

* Please contact SMC for other opening angles.

3 4 5 Top cover material

Base type 3	X2797	Rubber cover ^{*1}
	X3064	Metal cover
With manually operated handle 4	X2798	Rubber cover ^{*1}
	X3174	Metal cover
With manual handle lock 5	X3232	Rubber cover ^{*1}
	X3229	Metal cover

*1 Flame resistant (Equivalent to UL94 Standard V0)

6 Manually operated handle mounting position

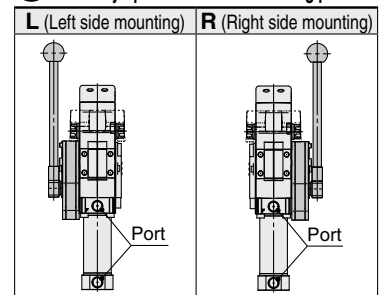

Clamp arm

CKZT 25 - A000 **C** S - X2797



Arm mounting position

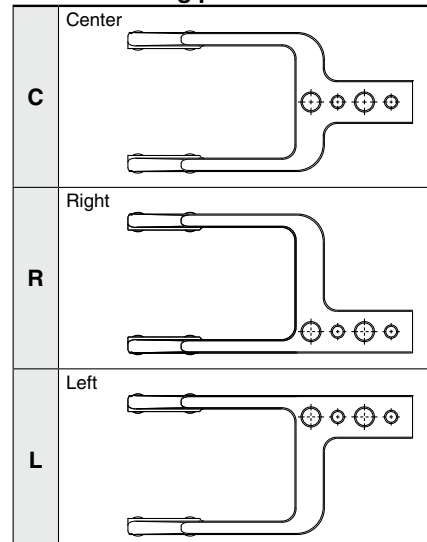

Cylinder Specifications

Bore size	25	32
Action	Double acting	
Fluid	Air	
Proof pressure	1.2 MPa	
Max. operating pressure	0.8 MPa	0.5 MPa
Min. operating pressure	0.3 MPa	
Ambient and fluid temperatures	-10 to 60°C (No freezing)	
Cushion	Clamping side: None Unclamping side: Rubber bumper	
Operating time	Clamping: 1 sec. or more, Unclamping: 1 sec. or more	
Max. allowable holding moment*1	75 N·m	

*1 Refers to the maximum holding force (torque) while clamped with the operating air exhausted. This is not the possible holding force (torque) for normal use.

Weight

Bore size	Base type cylinder	Cylinder with manually operated handle	With manual handle lock	Clamp arm	Extra weight is due to addition of the metal cover
25	580	820	960	230	30
32	710	950	1090	230	

* The weight is the same for both arm opening angles of 90° and 105°.

Cylinder Stroke

Bore size	Arm opening angle	
	90°	105°
25, 32	35.4	39.5

Proximity Switch Specifications

Part number	CKZ25-36-133NN-R
Manufacturer	SENSTRONIC
Power supply voltage	10 to 30 VDC
Output	N.O., PNP
Continuous load current	100 mA
Enclosure	IP67
Housing material	Aluminum alloy
Output indication	Clamping side: Red Unclamping side: Yellow
Power supply indication	Green
Connection cable length (M12 connector)	100 mm
Tightening torque for proximity switch mounting bolt	0.63 to 0.82 N·m

* Switch specifications correspond to the manufacturer's technical information.

Wiring Diagram (PNP Connection Circuit)

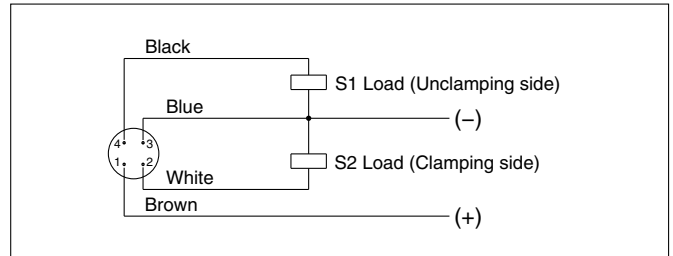

* Please contact SMC for NPN specifications.

Replacement Parts

Top Cover Kit No.

Rubber cover

CKZ25-53B781EL-R

Metal cover

CKZ25-53-1042T-R

* The top cover kit includes a top cover and mounting brackets. Refer to page 23 for top cover replacement instructions.

Power Clamp Cylinders
CKZM16
CKZT25/32
CKZT40
CKZ3T
CKZT80
CKZ3N
CKZ2N
C(L)KQG□
C(L)KQP□
C(L)KQ□D
-X3256
C(L)KQG32
C(L)KU32
C(L)KQG32
-X3036
Flow Control Equipment
Piping Equipment

Dimensions

CKZT□-□S-X2797 (Rubber cover type)
 -X3064 (Metal cover type)

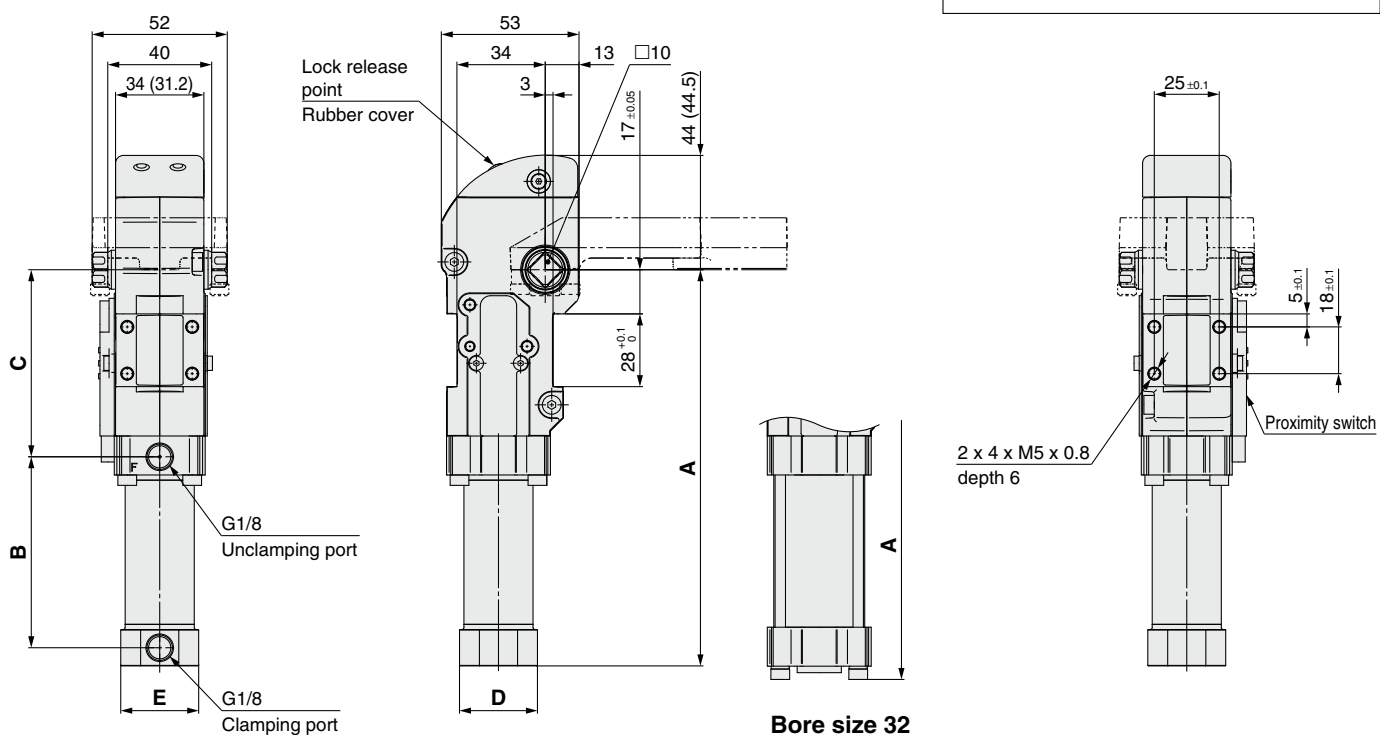

* Dimensions inside () are for metal cover type.

Bore size	Arm opening angle	A	B	C	D	E	Y
25	90°	148.4	69.4	72	30	30	76
	105°	152.5	73.5				
32	90°	157.7	73.6	71.5	40	35	
	105°						

Dimensions

* Refer to the CKZT□-□S-X2797 (page 19) for dimensions other than those shown below.

With manually operated handle

CKZT□-□S-X2798^R (Rubber cover type)
-X3174^R (Metal cover type)

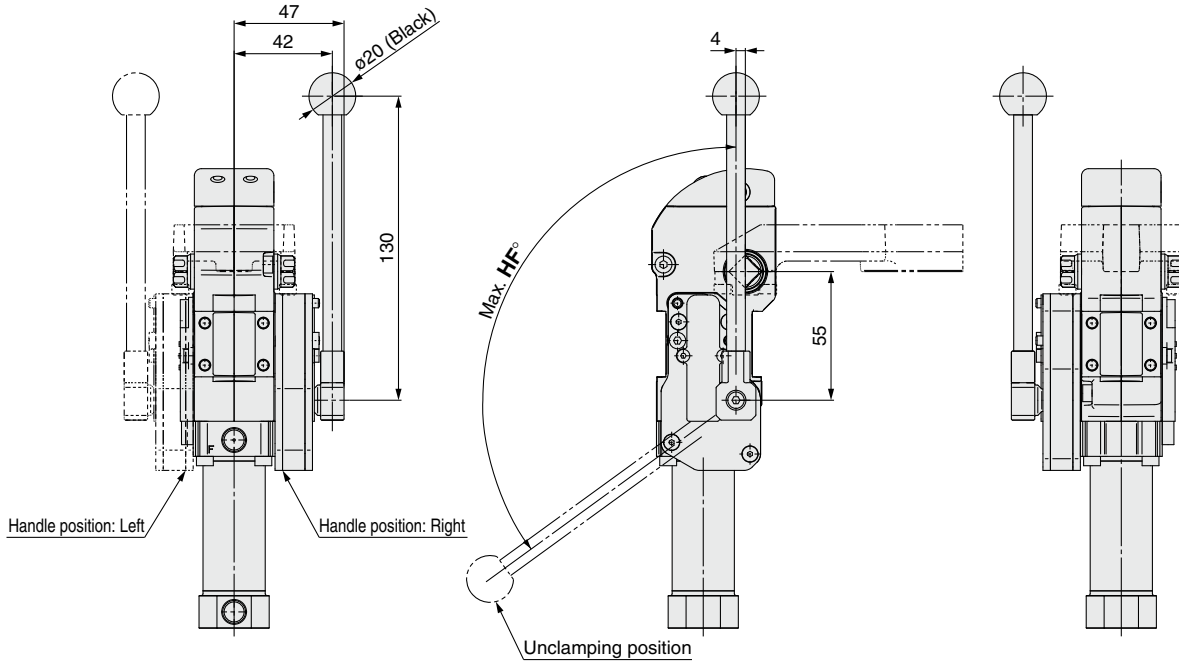

With manual handle lock

CKZT□-□S-X3232^R (Rubber cover type)
-X3229^R (Metal cover type)

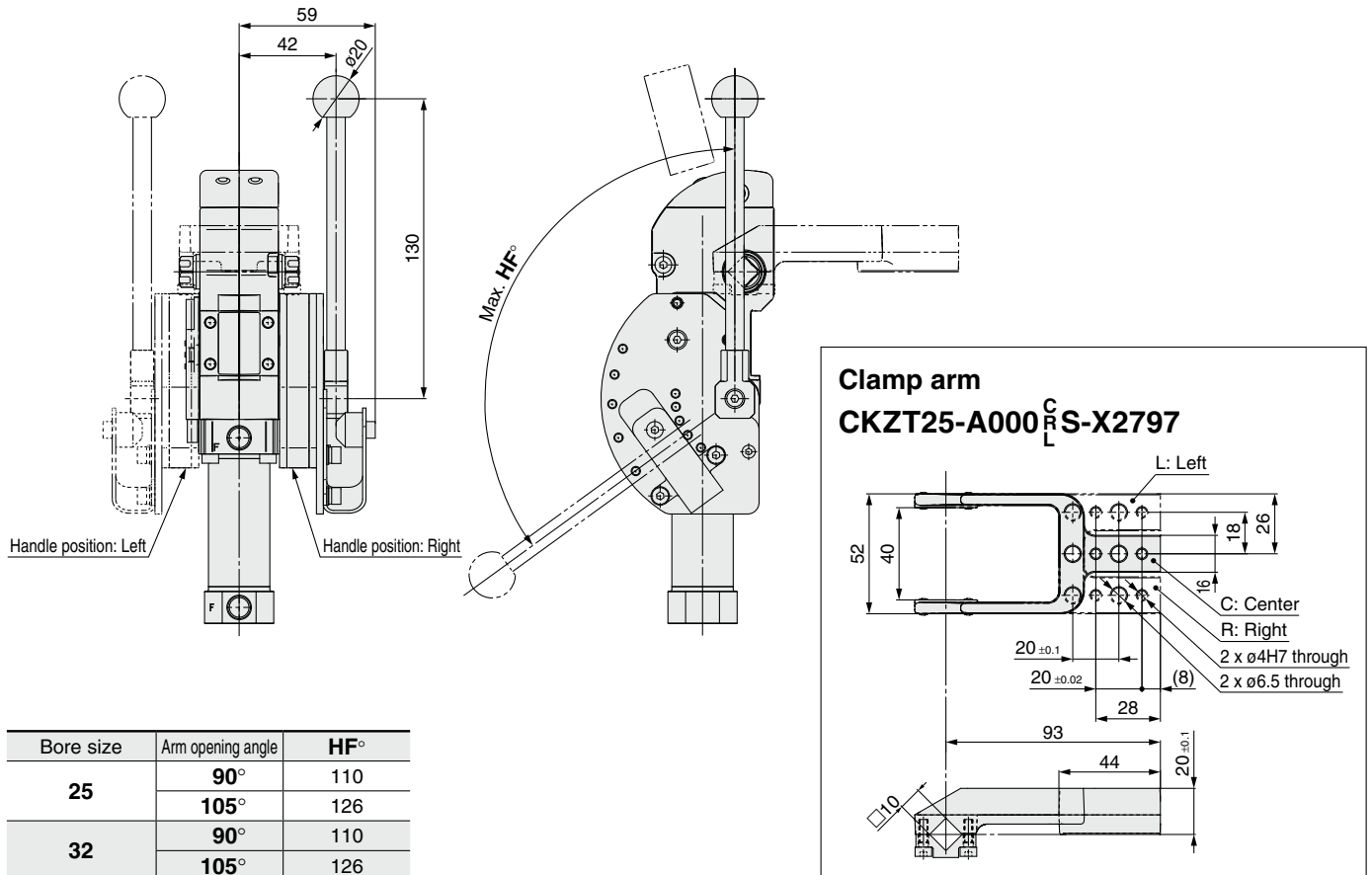

Bore size	Arm opening angle	HF°
25	90°	110
	105°	126
32	90°	110
	105°	126

Power Clamp Cylinders

CKZM16

CKZT25/32

CKZT40

CKZ3T

CKZT80

CKZ3N

CKZ2N

Related Products

C(L)KQG□
C(L)KQP□

C(L)KQ□D
-X3256

C(L)KQG32
C(L)KU32

C(L)KQG32
-X3036

Flow Control
Equipment

Piping
Equipment

CKZT Model Selection

-X2797, -X3064
 -X2798□, -X3174□
 -X3232□, -X3229□

Relation between arm length and clamping force

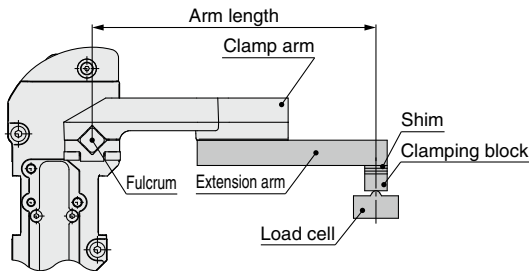

Bore Size: 25

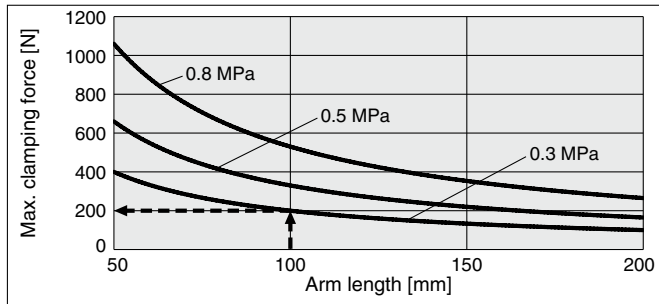

Bore Size: 32

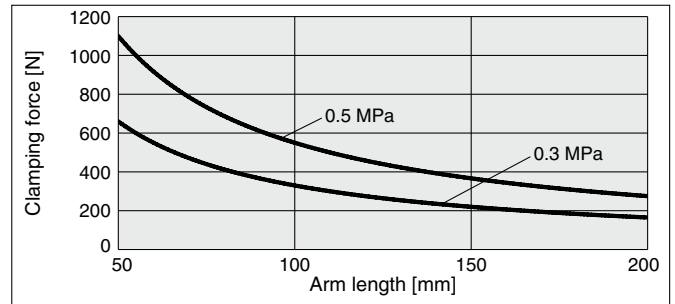

Calculation example The maximum clamping force when the arm length is 100 mm and the operating pressure is 0.3 MPa:

With an arm length of 100 mm and an operating pressure of 0.3 MPa, according to the graph, the maximum clamping force is 200 N.

Allowable arm length

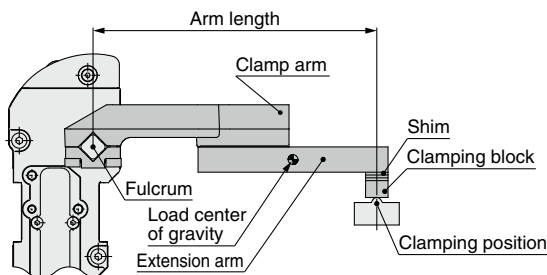

Bore size	Allowable arm length [mm]
25, 32	200

Allowable load mass

The allowable load mass changes depending on the arm opening angle. Be sure to use the product within the allowable values shown in the graph to the right.

- * The load indicates the total weight of the clamp arm, extension arm, and clamping block.
- * When the operating time is 1 second

Calculation procedure for allowable load mass

1. Calculate the distance L from the fulcrum to the load center of gravity.
2. Check the arm opening angle of the product.
3. Read the allowable load mass from the graph.

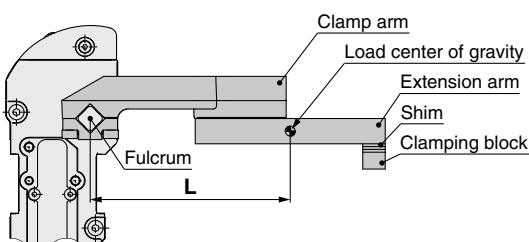

Bore Size: 25, 32

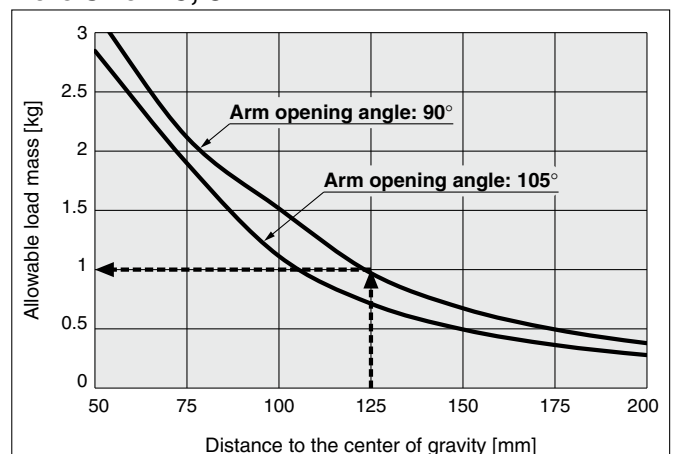

Calculation example Arm opening angle: 90°, Distance to the center of gravity L: 125 mm
 With an arm opening angle of 90° and a 125 mm distance to the center of gravity, according to the graph, the maximum allowable load mass is 1 kg.

Setup Procedure

Precautions

- 1) There is a mechanical difference of 0 to +0.5° at the clamping end as shown in Figure 1. Be sure to make adjustments externally using a shim. Refer to page 24.
- 2) Be sure to use a speed controller, and make adjustments according to the following conditions.

Unclamping to clamping: 1 second or more

Clamping to unclamping: 1 second or more

If excessive kinetic energy is applied, there is a possibility of damage.

- 3) When using a side guide:

Attach the side guide so that lateral loads, such as galling, etc., are not applied to the clamp arm.

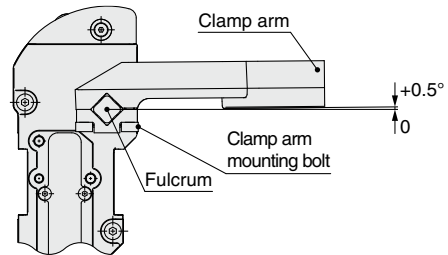
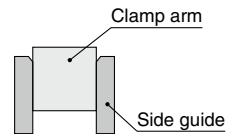

Figure 1



Clamp Arm Mounting Bolt Tightening Torque

Tightening torque [N·m]
1.5 to 1.8

Power clamp cylinder mounting and setup procedure

<Ex. 1 When using clamping force only: When equipped with a workpiece receptacle>

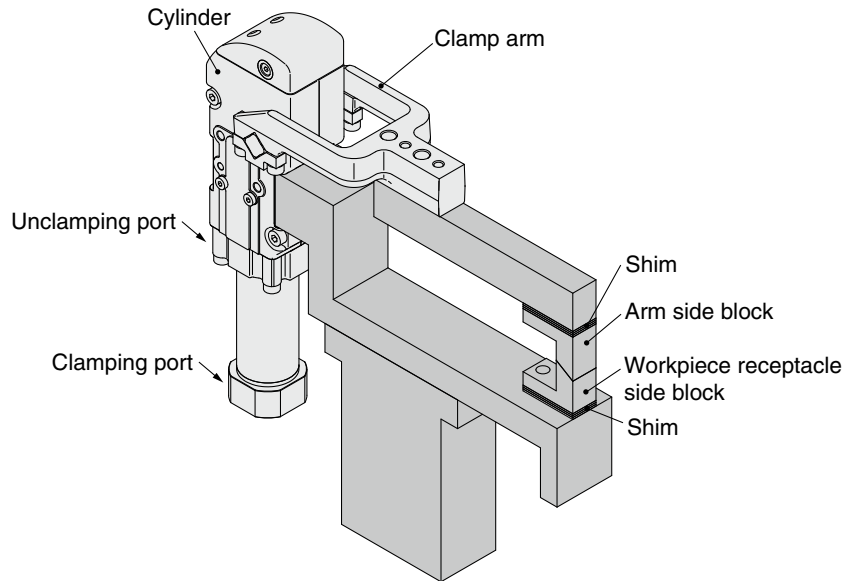

Procedure

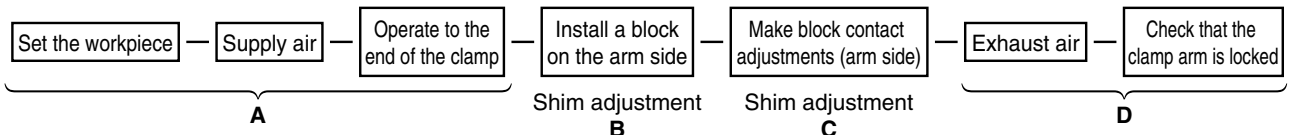

- Place the workpiece, supply air to the clamping port without attaching the block on the arm side, and operate the clamp arm to the end of the clamp.
- In the state of A), attach the workpiece and the arm side block, and adjust the shim so that there is a space of about 0 mm. During this step, theoretically, there is no clamping force pressing down on the workpiece.
- In order to generate a clamping force from the state described in step B), insert an additional shim. The thickness of the shim changes depending on the arm length and the operating pressure. Refer to page 24. Please note that the graph should only be used as a guide, as there is a tolerance of about 10% in the clamp cylinder body.
- Exhaust the air while in the clamped state, and confirm that the clamp arm does not open.

Power Clamp Cylinders	CKZM16
	CKZT25/32
	CKZT40
	CKZ3T
Related Products	C(L)KQG□ C(L)KQP□
	C(L)KQ□D -X3256
	C(L)KQG32 C(L)KU32
Flow Control Equipment	C(L)KQG32 -X3036
	Piping Equipment

Power clamp cylinder mounting and setup procedure

<Ex. 2 When using a hard stop: When not equipped with a workpiece receptacle>

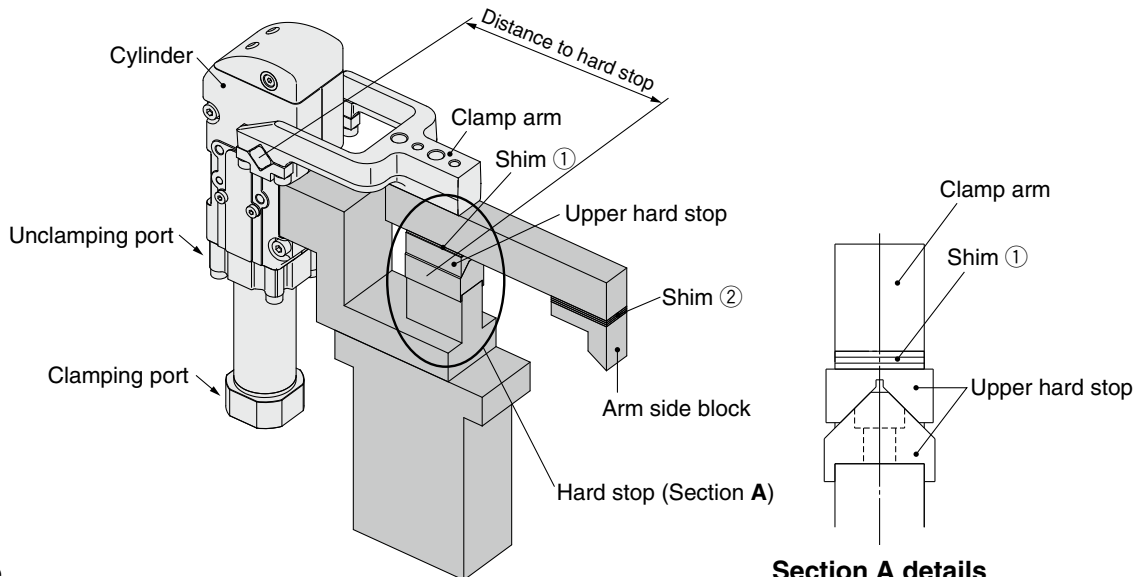

Procedure

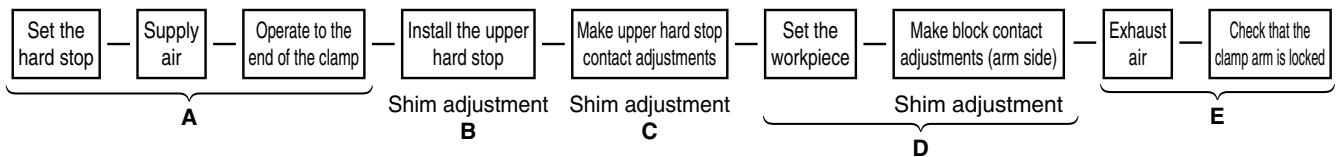

- A) Supply air to the clamping port without installing the upper hard stop, and operate the clamp arm to the end of the clamp.
- B) In the state of A), attach the upper hard stop and adjust the shim ① so that there is a space of about 0 mm between the upper hard stop and the hard stop.
 During this step, theoretically, there is no clamping force applied to the hard stop.
- C) In order to generate a clamping force from the state described in step B), insert an additional shim.
 The thickness of the shim changes depending on the distance to the hard stop and the operating pressure. Refer to page 24, and consider the distance to the hard stop as the arm length.
 Please note that the graph should only be used as a guide, as there is a tolerance of about 10% in the clamp cylinder body.
- D) In the state of C), adjust shim ② so that the arm side block contacts the workpiece.
- E) Exhaust the air while in the clamped state, and confirm that the clamp arm does not open.

Top cover replacement

⚠ Caution Be sure to confirm safety and perform installation while the air is exhausted.

- 1) Mount the top cover to the clamp cylinder, then tighten to the specified tightening torque below.

*1 It is not possible to change between cover materials afterwards (rubber cover type/metal cover type).

*2 Refer to Replacement Parts (page 18) for the part numbers of the top cover replacement parts.

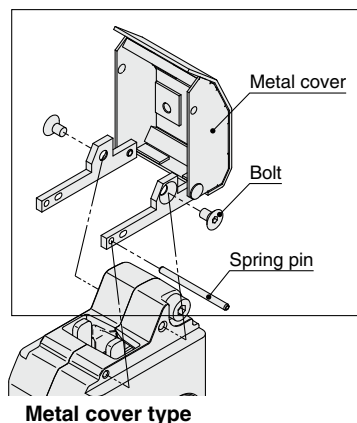
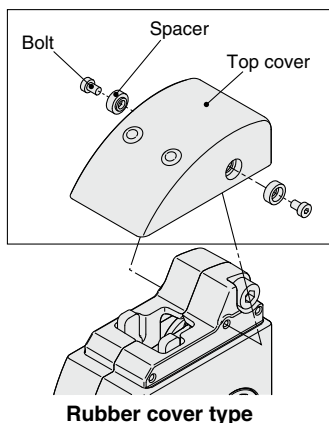

Top Cover Mounting Bolt Tightening Torque (Rubber cover type)

Bore size	Tightening torque [N·m]
25, 32	0.63 to 0.82

Top Cover Mounting Bolt Tightening Torque (Metal cover type)

Bore size	Tightening torque [N·m]
25, 32	0.63 to 0.82

Relation between shim thickness and clamping force

- * Use this figure as a guide, as there is a tolerance of about 10% in the clamp cylinder body.
- * When a shim exceeding the peak clamping force position on the graph is inserted, the lock will not be activated when clamped. Insert a shim of the appropriate thickness.
- *1 The arm length indicates the distance between the clamp arm shaft and the clamping position.

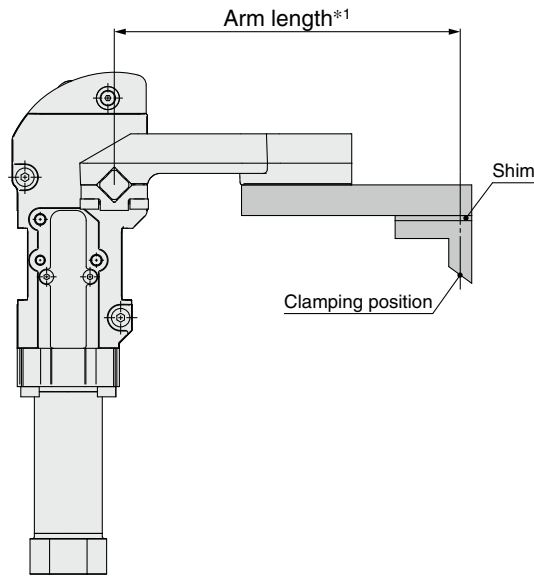

Bore Size: 25

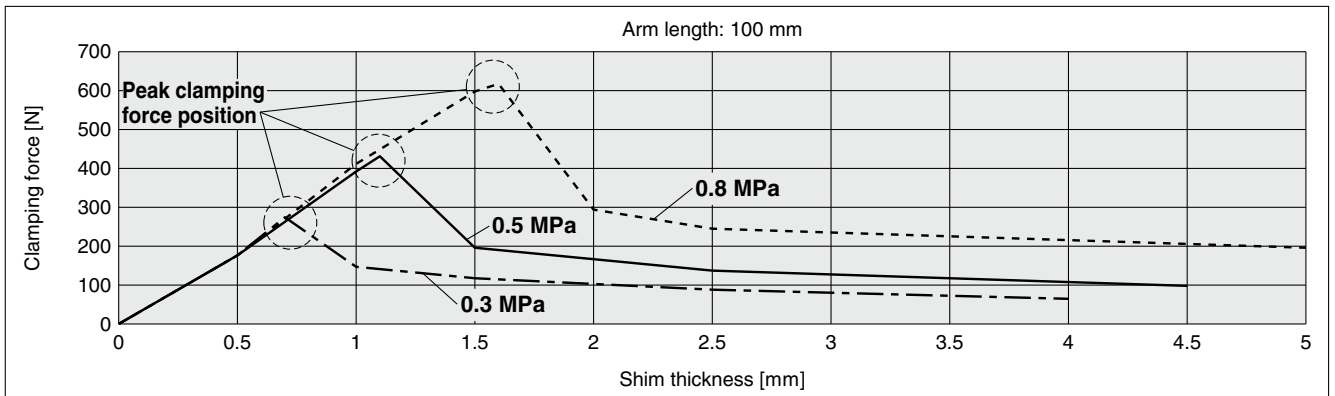

Bore Size: 32

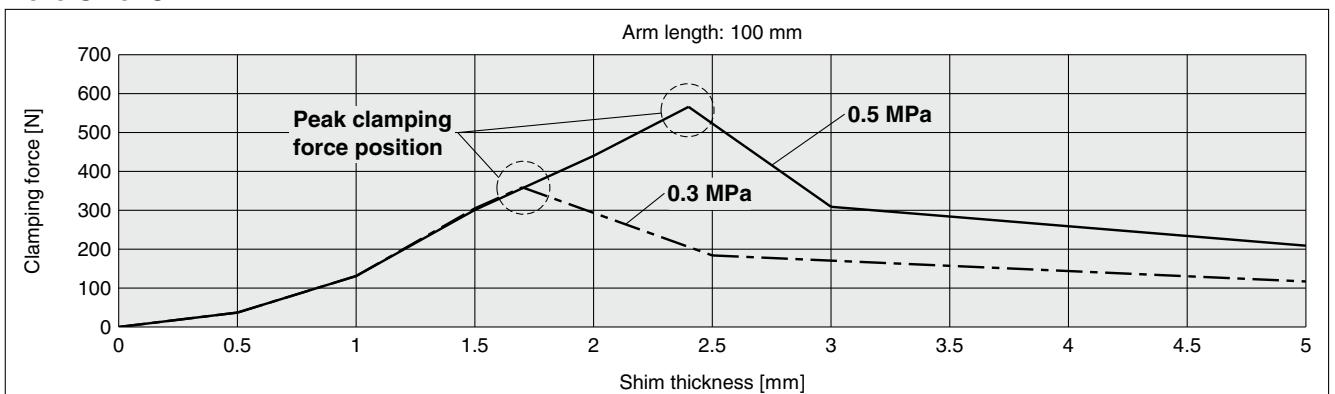

Power Clamp Cylinders

CKZM16
CKZT25/32
CKZT40
CKZ3T
CKZT80
CKZ3N
CKZ2N

Related Products

C(L)KQG□
C(L)KQP□
C(L)KQ□D
-X3256
C(L)KQG32
C(L)KU32
C(L)KQG32
-X3036
Flow Control Equipment
Piping Equipment



Specific Product Precautions

Be sure to read this before handling the products. Refer to page 151 for safety instructions. For actuator precautions, refer to the “Handling Precautions for SMC Products” and the “Operation Manual” on the SMC website: <https://www.smcworld.com>

⚠ Caution

1. Manual lock release

Be sure to confirm safety before manually releasing the lock, and only perform work **while the air is exhausted**. Otherwise, the clamp arm may operate unexpectedly.

- In the case of a rubber cover, the lock can be released easily by hitting the round tab on the cover with a plastic hammer.
- In the case of a metal cover, the lock can be released easily by opening the cover and hitting the tab of the knuckle joint with a plastic hammer.

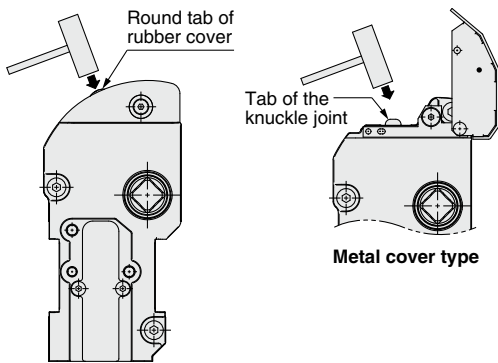

Rubber cover type

Metal cover type

- Provide enough space to perform a manual lock release.

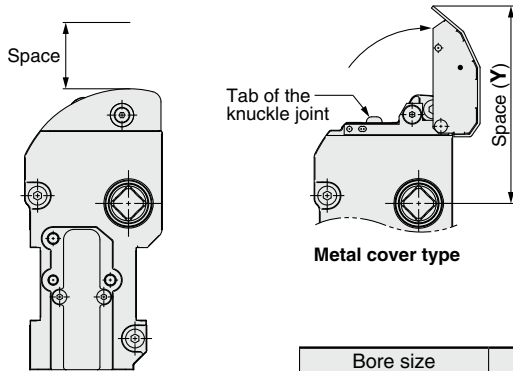

Rubber cover type

[mm]	
Bore size	Y
25, 32	76

2. Do not disassemble the power clamp cylinder.

The power clamp cylinder consists of a completely sealed structure in order to protect it from welding spatter. Do not disassemble, except for when replacing any of the replaceable parts, as this may cause the performance to deteriorate.

⚠ Caution

3. Vertical clamping

When mounting the clamp arm in a vertical clamping position, mount as shown in the figure below.

In the case of a metal cover, the metal cover and clamp arm will interfere and the lock cannot be released manually.

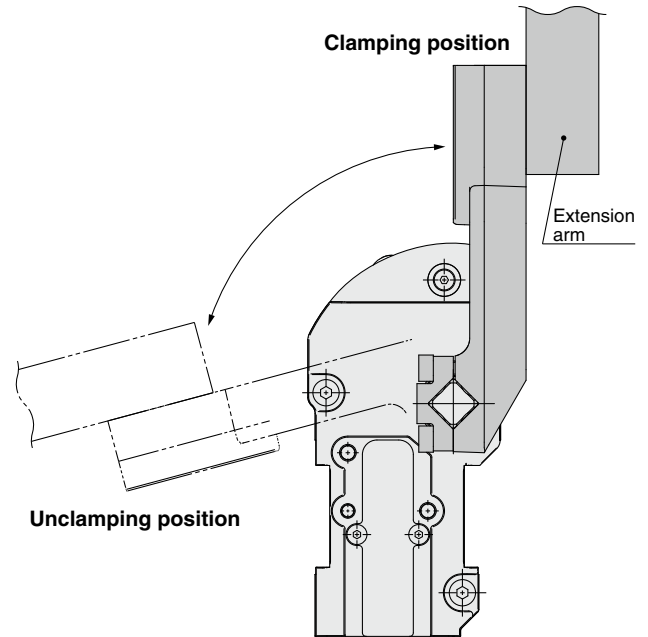

4. Proximity switch output

The switch output signal is output near the clamping end and the unclamping end respectively.

The switch output signal on the clamping side does not output the status where the power clamp cylinder is locked by the toggle mechanism.

5. With manually operated handle

Operating force of the handle should be 70 N or less. Excessive forces applied to the handle will lead to breakage or deformation.

6. Operating time and allowable load mass

Fast operation (short stroke times) or excessive loads will lead to the breakage or deformation of the product. It is recommended to install shock absorbers to reduce impact force in these instances.