

Radial piston pump

PR4 series 1X

RE 11260

Edition: 07.2015

Replaces: 08.2005



PR4-1X/1,00-450WA01M01

- ▶ Fixed displacement
- ▶ Sizes 0,40 to 2,00
- ▶ Maximum working pressure 700 bar
- ▶ Maximum displacement 2 cm³

Features

- ▶ Self-priming, valve-controlled
- ▶ Very low noise
- ▶ Long service life due to hydrodynamically lubricated slide bearings
- ▶ Very compact design, therefore installation-friendly dimensions
- ▶ Combination options with fixed and variable vane pumps
- ▶ Five sizes

Contents

Type code	2
Functional description	3
Technical data	4
Sound pressure level	5
Flow/drive power	5
Dimensions	6
Installation instructions	8
Project planning notes	9
Commissioning instructions	9
Spare parts	10

Type code

01	02	03	04	05	06	07	08	09	
PR4	-	1X	/		W		01		*

Type

01	Radial piston pump, fixed displacement, maximum pressure 700 bar	PR4
----	--	------------

Series

02	10 to 19 (10 to 19: unchanged installation and connection dimensions)	1X
----	---	-----------

Size (NG)

	NG	Pressure stage	
03 Size – pressure stage (maximum) (all sizes have three pistons)	0,40	700 bar	0,40-700
	0,63	700 bar	0,63-700
	1,00	450 bar	1,00-450
	1,60	250 bar	1,60-250
	2,00	175 bar	2,00-175

Direction of rotation

04	Viewed on drive shaft	clockwise and counter-clockwise	W
----	-----------------------	---------------------------------	----------

Drive shaft

05	Parallel keyed shaft	A
	Splined shaft 10 × 12, DIN 5481 (for combination with vane pumps)	G

Line connection

06	Pipe thread, ISO 228/1	01
----	------------------------	-----------

Sealing material

07	NBR seals (nitrile rubber)	M
	FKM seals (fluoroelastomer)	V

Pressure ports

08	1 pressure port	01
	3 pressure ports	03

09	Further specifications in plain text	*
----	--------------------------------------	---

Design versions for multi circuit pumps

The following schematic diagrams show:

- ▶ the number and position of the pressure ports
- ▶ which cylinders are interconnected.

The dots indicate the cylinders that are connected directly to the pressurized pressure port.

The circles indicate the cylinders that are not connected directly to the pressurized pressure port.

The dotted and chain-dotted lines show, which cylinders are interconnected.

The designation sequence of the pressurized pressure ports is in clockwise direction.

The pressure port which is closest to the suction port on clockwise direction is labeled with **P1**.

Code (Pos. 08)	Number of pressure ports	3 pistons
01	1	
03	3	

Functional description

Assembly

The pumps are valve-controlled, self-priming radial piston pumps with fixed displacement.

They consist essentially of the housing (1), eccentric shaft (2) and pump elements (3), with suction valve (4), pressure valve (5) and piston (6).

Suction and displacement process

Pistons (6) are arranged radially to the eccentric shaft (2). The piston (6) is guided in cylinder (7) and pressed against the eccentric (2) by the spring (8). During the downward movement of piston (6), the working chamber (9) in the cylinder (7) increases in size. The resulting negative pressure lifts the suction valve plate (4.1) from the sealing edge. This opens the connection from the suction chamber (10) to the working chamber (9). The working chamber fills with fluid. During the upward movement of piston (6), the suction valve closes and the pressure valve (5) opens. Fluid can now flow to the system via pressure port (P).

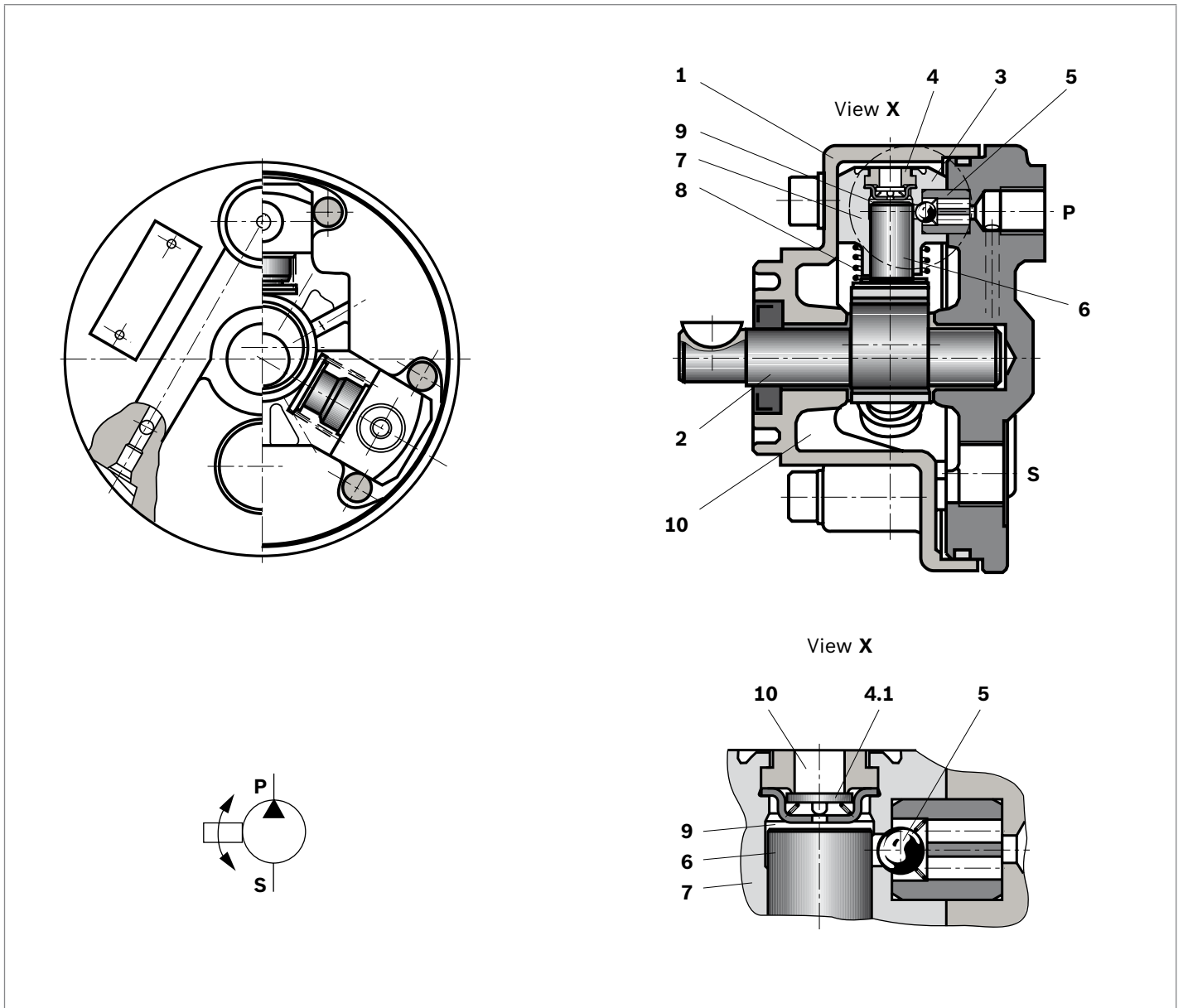

Technical data

Size		NG	0,40	0,63	1,00	1,60	2,00	
Displacement, geometric	V_g	cm ³	0.4	0.63	1	1.6	2	
Drive speed	n_{min}	rpm	1000	1000	1000	1000	1000	
	n_{max}	rpm	3400	3000	2000	2000	2000	
Working pressure (absolute)								
Inlet	p	bar	0.8 to 1.5					
Outlet	continuous	p_N	bar	700	700	450	250	175
Torque, maximum (drive shaft)		Nm	10	10	10	10	10	
Weight	m	kg	2.6	2.6	2.6	2.6	2.6	
Shaft load	Radial and axial forces cannot be absorbed!							
Mounting type	Front face mounting							
Line connections	Screw-in fittings							
Direction of rotation (viewed to drive shaft)	Counter-clockwise or clockwise, has no influence on the flow direction							
Hydraulic fluid								
Permissible hydraulic fluid ¹⁾	HLP mineral oil according to DIN 51524 part 2							
Operating temperature range	-10 to +70 °C							
Viscosity range	10 to 200 mm ² /s							
Maximum admissible degree of contamination of the hydraulic fluid	Class 20/18/15 ¹⁾							
Cleanliness level according to ISO 4406 (c)								

Note

- ▶ Please contact us if the unit is to be used outside the specified values.
- ▶ Observe our specifications according to data sheet 90220.
- ▶ Information on the installation position, see page 8

1) Cleanliness levels specified for the components must be maintained in the hydraulic systems. Effective filtration prevents malfunctions and simultaneously extends the service life of the components. When selecting filters, see data sheet RE 51144.

Sound pressure level

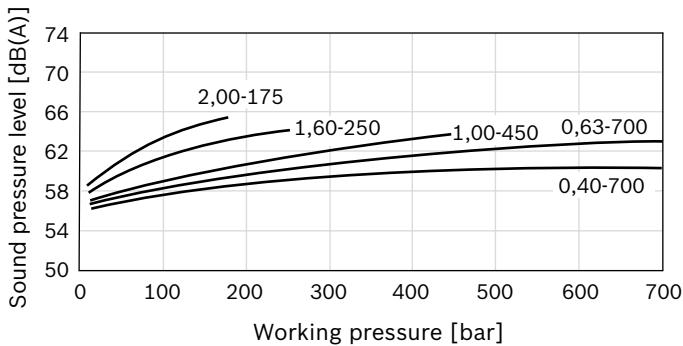

Note

- ▶ Characteristic curves are mean values, measured at $n = 1450 \text{ rpm}$; $\nu = 41 \text{ mm}^2/\text{s}$, $\theta = 50 \text{ }^\circ\text{C}$
- ▶ Sound pressure level measured in acoustic room according to DIN 45635, part 26
- ▶ Distance: Microphone – pump = 1 m
- ▶ At a system pressure below 4 bar and a viscosity $> 150 \text{ mm}^2/\text{s}$ audible valve noise may occur.
- ▶ Sound pressure level at system pressure $< 4 \text{ bar}$: $\leq 58 \text{ dB(A)}$.

Flow/drive power¹⁾

NG - p_{\max}	$V_g [\text{cm}^3]$	Pressure [bar]	50	100	150	200	250	300	350	400	450	500	550	600	650	700
0,40-700	0.40	$q_{V, \text{eff}} [\text{l/min}]$	0.55	0.54	0.54	0.53	0.53	0.52	0.51	0.50	0.50	0.49	0.49	0.48	0.48	0.47
		$P_A [\text{kW}]$	0.07	0.12	0.16	0.20	0.25	0.30	0.34	0.39	0.43	0.48	0.52	0.57	0.61	0.66
0,63-700	0.63	$q_{V, \text{eff}} [\text{l/min}]$	0.95	0.94	0.93	0.92	0.91	0.90	0.89	0.88	0.88	0.87	0.86	0.85	0.84	0.83
		$P_A [\text{kW}]$	0.10	0.18	0.26	0.34	0.42	0.51	0.58	0.67	0.74	0.82	0.90	0.98	1.07	1.15
1,00-450	1.00	$q_{V, \text{eff}} [\text{l/min}]$	1.47	1.45	1.43	1.41	1.40	1.39	1.38	1.37	1.36	-	-	-	-	-
		$P_A [\text{kW}]$	0.16	0.28	0.41	0.53	0.66	0.77	0.89	1.02	1.14	-	-	-	-	-
1,60-250	1.60	$q_{V, \text{eff}} [\text{l/min}]$	2.35	2.35	2.34	2.33	2.33	-	-	-	-	-	-	-	-	-
		$P_A [\text{kW}]$	0.22	0.43	0.64	0.85	1.06	-	-	-	-	-	-	-	-	-
2,00-175	2.00	$q_{V, \text{eff}} [\text{l/min}]$	2.98	2.97	2.96	-	-	-	-	-	-	-	-	-	-	-
		$P_A [\text{kW}]$	0.31	0.58	0.86	-	-	-	-	-	-	-	-	-	-	-

Uniformity coefficient f relative to $n = 1450 \text{ rpm}$

The values from “Flow/drive power” table relate to 1 cylinder each.

To determine the required drive power, multiply the specified value by the number of cylinders. The uniformity coefficient f should be taken into account.

Radial piston pump – 3 cylinders	
Loaded cylinder	Factor f
1	3.13
1+2	1.57
1+2+3	1.00

▼ Example: Pump PR4-1X/0.63-700WA01M03

Port 1 and 2, each loaded with 450 bar, 3 is circulating at zero pressure.

$$P_A = 2 \times 0.74 \text{ kW} = 1.48 \text{ kW}$$

$$f = 1.57$$

$$P_{\text{erf}} = 1.48 \text{ kW} \times 1.57 = 2.32 \text{ kW}$$

Port 3 loaded with 300 bar, 1 and 2 run without pressure.

$$P_A = 1 \times 0.51 \text{ kW} = 0.51 \text{ kW}$$

$$f = 3.13$$

$$P_{\text{erf}} = 0.51 \text{ kW} \times 3.13 = 1.59 \text{ kW}$$

Port 1, 2 and 3, each loaded with 200 bar.

$$P_A = 3 \times 0.34 \text{ kW} = 1.02 \text{ kW}$$

$$f = 1$$

$$P_{\text{erf}} = 1.02 \text{ kW} \times 1 = 1.02 \text{ kW}$$

¹⁾ Mean values measured at $n = 1450 \text{ rpm}$, $\theta = 50 \text{ }^\circ\text{C}$

Dimensions

Design with one pressure port

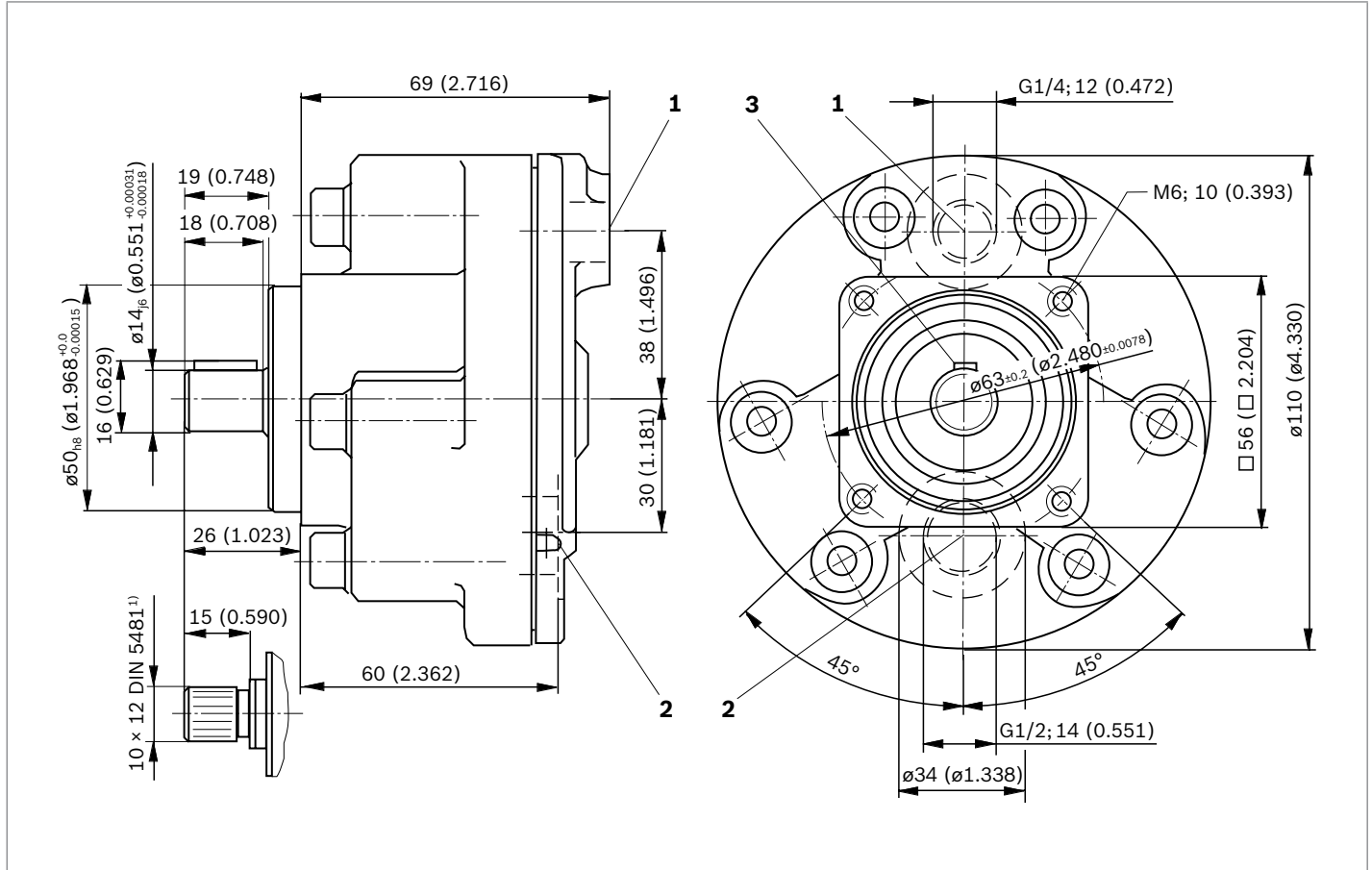

- 1 Pressure port **P**
- 2 Suction port **S**
- 3 Woodruff key 5 × 6.5 DIN 6888

1) Splined shaft

Installation instructions

Fluid reservoir

- ▶ Match the usable reservoir volume to the operating conditions.
- ▶ The permissible fluid temperature may not be exceeded, if required, provide a cooler!

Lines and ports

- ▶ Remove protection plugs from the pump.
- ▶ We recommend the use of seamless precision steel pipes according to DIN EN 10305-1 and removable pipe connections.
- ▶ Select the clear width of pipes according to the ports (suction speed 1 to 1.5 m/s).
- ▶ Inlet pressure, see page 4
- ▶ Thoroughly clean pipelines and fittings prior to installing.

Proposal for piping layout

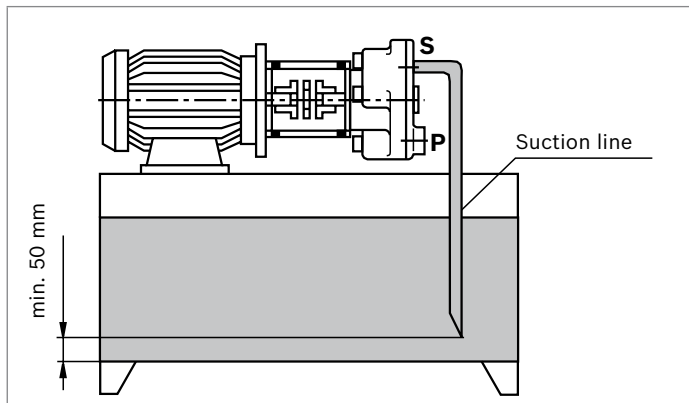

- ▶ Under no circumstances may drain and returning fluid be drawn directly into the suction port again, i.e., select the largest possible distance between suction line and return line.
- ▶ The return drain must always be below the oil level.
- ▶ Ensure suction-tight installation of the pipes.

Filters

If possible, use return line filters or pressure filters.
(use suction filters only in combination with underpressure switch/contamination indicator).

Hydraulic fluid

- ▶ Please observe our specifications according to data sheet 90220.
- ▶ We recommend brand name hydraulic fluids.
- ▶ Do not mix hydraulic fluids of different types since this can result in decomposition and deterioration of the lubricity.

- ▶ The hydraulic fluid must be replaced at regular intervals according to the operating conditions. When doing this, the hydraulic fluid reservoir must also be cleaned of residues.

Drive

Electric motor + pump mounting bracket + coupling + pump

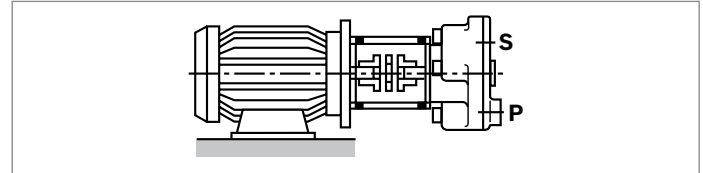

- ▶ No radial or axial forces permissible on the pump drive shaft!
- ▶ Motor and pump must be exactly aligned!
- ▶ Always use a coupling that is suitable for compensating for shaft offsets!
- ▶ When installing the coupling, avoid axial forces, i.e., when installing, do not hammer or press the coupling onto the shaft. Use the female thread on the drive shaft.

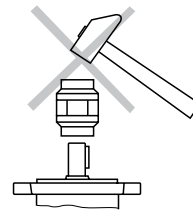

Installation positions

- ▶ Horizontal installation (**B3, B5**): always position the suction port above the pressure port. This arrangement ensures improved pump air bleeding.
- ▶ Vertical installation (**V1**): no limitations

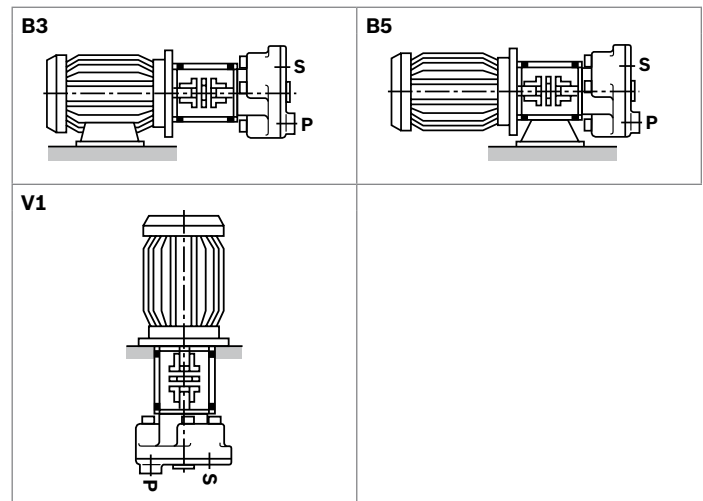

Project planning notes

When using radial piston pumps, the following notes should be observed in particular.

The project planning, installation and commissioning of the radial piston pump require the involvement of qualified skilled personnel.

Technical data

All the technical data are dependent on manufacturing tolerances and are valid with certain operating conditions. Please note that certain deviations are therefore possible, and that technical data may vary when boundary conditions (e.g. viscosity) change.

Characteristic curves for flow and absorbed power

When designing the drive motor, observe the maximum possible application data.

Noise

The sound pressure level values shown on page 5 were measured according to DIN 45635 part 26. This means that only the noise emitted by the pump is depicted. Ambient influences (such as place of installation, piping, etc.) are not taken into consideration. The values only refer to one pump. During pressure-free operation, the pressure line must be pre-charged with a check valve (cracking pressure $p = 5$ bar) due to noise development.

Note

Due to the power unit design and influences at the final place of installation of the pump, the noise pressure level is usually 5 to 10 dB(A) higher than the value of the pump itself.

Commissioning instructions

Air bleeding

- ▶ All PR4 radial piston pumps are self-priming.
- ▶ Fill the housing with filtered oil via port S.
- ▶ During initial commissioning, set the pump to pressureless circulation. To do so, release the pressure hose and direct it into the reservoir.
- ▶ Before initial commissioning, the pump must be air-bled to protect it against damage.
- ▶ Switch to pressureless circulation, or direct the pressure line or pressure hose back into the reservoir.
- ▶ Briefly switch the pump on (inching mode).
- ▶ Should the pump not displace bubble-free oil after approx. 20 seconds, re-check the system. After the operating values have been reached, check the pipe connections for leakage. Check the operating temperature.
- ▶ Be aware of noise generation.

Commissioning

- ▶ Check whether the system is thoroughly and properly installed.
- ▶ Start the pump without load and let it displace fluid without pressure for a few seconds in order to ensure sufficient lubrication.
- ▶ **In no case may the pump be operated without hydraulic fluid!**

Note

- ▶ Adjustment, maintenance and repair of the pump may only be carried out by authorized, trained and instructed personnel!
- ▶ Use only original Rexroth spare parts!
- ▶ The pump may only be operated within the permissible data.
- ▶ The pump may only be operated when in perfect condition!
- ▶ When carrying out any work on the pump (e.g. installation and removal) the system must be switched off and depressurized!
- ▶ Unauthorized conversions and changes, affecting the safety and function are not permissible!
- ▶ Mount protective devices (e.g., coupling protection)!
- ▶ Do not remove any existing protective devices!
- ▶ The generally valid safety and accident prevention regulations must be strictly observed!

Spare parts

Designation	Material number
NBR seal kit	R900312138
FKM seal kit	R900313049

(valid for all sizes)

Information on available spare parts:

www.boschrexroth.com/spc

Bosch Rexroth AG

Mobile Applications
Zum Eisengießer 1
97816 Lohr am Main, Germany
Phone +49 9352 18-0
info.ma@boschrexroth.de
www.boschrexroth.com

© This document, as well as the data, specifications and other information set forth in it, are the exclusive property of Bosch Rexroth AG. It may not be reproduced or given to third parties without its consent. The data specified above only serve to describe the product. No statements concerning a certain condition or suitability for a certain application can be derived from our information. The information given does not release the user from the obligation of own judgment and verification. It must be remembered that our products are subject to a natural process of wear and aging.