

Duplex filter with filter element according to DIN 24550

Type 63FLDKN0063 to 0250;
63FLDK0130, 0150

RE 51445

Edition: 03.15

Replaces: 01.14



HAD7934_12

- ▶ Size **according to DIN 24550**: 0063 to 0250
- ▶ Additional sizes: 0130, 0150
- ▶ Nominal pressure 63 bar [913 psi]
- ▶ Connection up to SAE 2" 3000 psi
- ▶ Operating temperature -10 °C to $+100\text{ °C}$ [14 °F to 212 °F]

Features

Duplex filters are used in hydraulic systems for separating solid materials from fluids and lubricating oils.

They are intended for installation into pipelines and allow for the exchange of the filter element without operational interruption.

They distinguish themselves by the following:

- ▶ Filters for inline installation, switchable
- ▶ Special highly efficient filter materials
- ▶ Filtration of very fine particles and high dirt holding capacity across a broad pressure differential range
- ▶ High collapse rating of the filter elements
- ▶ By default equipped with mechanical optical maintenance indicator with memory function
- ▶ Various, optional electronic switching elements, modular design
- ▶ Optional bypass valve integrated in the filter housing
- ▶ Measuring port as standard at the switch housing
- ▶ Gas-tight switch-over via ball valve
- ▶ Improved filtration through integrated cyclone flow path

Contents

Features	1
Ordering code filter	2, 3
Preferred types	4
Ordering code accessories	5
Symbols	6
Function, section	7
Technical data	8, 9
Compatibility with hydraulic fluids	9
Characteristic curves	10, 11
Dimensions	12 ... 15
Maintenance indicator	16
Ordering code spare parts	17 ... 19
Assembly, commissioning, maintenance	20, 21
Tightening torques	22
Directives and standardization	22, 23

Ordering code

Filter

01	02	03	04	05	06	07	08	09	10	10	10	10	10	10	10
63FLDK			- 1X /			-	-	-	-	-	-	-	-	-	-

Series

01	Duplex filter 63 bar [913 psi]	63FLDK
----	--------------------------------	--------

Filter element

02	With filter element according to DIN 24550	N
----	---	---

Size

03	FLDKN...	0063 0100 0160 0250
	FLDK...	0130 0150

04	Component series 10 ... 19 (10 ... 19: Unchanged installation and connection dimensions)	1X
----	---	----

Filter rating in µm

05	Nominal	Stainless steel wire mesh, cleanable	G10 G25 G40 G60 G100
		Paper, not cleanable	P10 P25
	Absolute (ISO 16889)	Glass fiber material, not cleanable	H3XL H6XL H10XL H20XL

Pressure differential

06	Max. admissible pressure differential of the filter element 30 bar [435 psi], with bypass valve	A00
	Max. admissible pressure differential of the filter element 160 bar [2320 psi], without bypass valve	C00

Maintenance indicator

07	Maintenance indicator, mech./optical, switching pressure 0.8 bar [11.6 psi] – bypass cracking pressure 3.5 bar [51 psi]	V0,8
	Maintenance indicator, mech./optical, switching pressure 1.5 bar [21.8 psi] – bypass cracking pressure 3.5 bar [51 psi]	V1,5
	Maintenance indicator, mech./optical, switching pressure 2.2 bar [32 psi] – bypass cracking pressure 3.5 bar [51 psi]	V2,2
	Maintenance indicator, mech./optical, switching pressure 5.0 bar [72.5 psi] – (only in connection with amending information "NB" or C element = without bypass)	V5,0

Seal

08	NBR seal	M
	FKM seal	V

Connection

09	Frame size	0063-0100	0130-0150	0160-0250			
	Connection						
	SAE 1"	●				SAE flange 3000 psi	S4
	SAE 1 1/2"		●	X			S6
	SAE 2"			●			S8
	<input checked="" type="checkbox"/> Standard connection <input type="checkbox"/> Alternative connection						

Ordering code Filter

01	02	03	04	05	06	07	08	09	10	10	10	10	10	10	10
63FLDK			- 1X /			-	-	-	-	-	-	-	-	-	-

Supplementary information

10	Pressure equalization line	A
	Bleed valve	E
	Optional floor mounting (standard = wall mounting)	FB
	Threaded coupling G 1/8 (size 0063 to 0100) and/or G 1/4 (size 0130 to 0250) at the switch housing (instead of plug screw)	M
	Without bypass valve (only possible in connection with filter element version "A00") ¹⁾	NB
	Manufacturer's inspection certificate M according to DIN 55350 T18	Z1

¹⁾ **Attention:** If this option is selected and the switching signal of the maintenance indicator is not observed during operation, the filter element may collapse in case of pressure differentials of more than 30 bar [435 psi].

Order example:

63FLDKN0100-1X/H3XLA00-V2,2-M-S4

Further versions (filter materials, ship classification GL or LRS, etc.) available at request.

Preferred types

63FLDK(N) preferred types, NBR seal, flow specifications for 30 mm²/s [143 SUS]

Duplex filter, filter rating 3 µm

Type	Flow in l/min [US gpm] with $\Delta p = 1$ bar [14.5 psi] ¹⁾	Material no. Filters				Material no. Replacement element
63FLDKN0063-1X/H3XLA00-V2,2-M-..	68 [17.96]	..S4	R928053186			R928005853
63FLDKN0100-1X/H3XLA00-V2,2-M-..	93 [24.57]	..S4	R928053187			R928005871
63FLDK0130-1X/H3XLA00-V2,2-M-..	146 [38.57]	..S6	R928053188			R928037178
63FLDK0150-1X/H3XLA00-V2,2-M-..	235 [62.08]	..S6	R928053189			R928037181
63FLDKN0160-1X/H3XLA00-V2,2-M-..	210 [55.48]	..S8	R928053191	..S6	R928053190	R928005889
63FLDKN0250-1X/H3XLA00-V2,2-M-..	291 [76.87]	..S8	R928053192	..S6	R928053193	R928005925

63FLDK(N) preferred types, NBR seal, flow specifications for 30 mm²/s [143 SUS]

Duplex filter, filter rating 6 µm

Type	Flow in l/min [US gpm] with $\Delta p = 1$ bar [14.5 psi] ¹⁾	Material no. Filters				Material no. Replacement element
63FLDKN0063-1X/H6XLA00-V2,2-M-..	75 [19.81]	..S4	R928053194			R928005854
63FLDKN0100-1X/H6XLA00-V2,2-M-..	102 [26.95]	..S4	R928053195			R928005872
63FLDK0130-1X/H6XLA00-V2,2-M-..	165 [43.59]	..S6	R928053196			R928045104
63FLDK0150-1X/H6XLA00-V2,2-M-..	230 [60.76]	..S6	R928053197			R928037182
63FLDKN0160-1X/H6XLA00-V2,2-M-..	220 [58.12]	..S8	R928053199	..S6	R928053198	R928005890
63FLDKN0250-1X/H6XLA00-V2,2-M-..	294 [77.66]	..S8	R928053201	..S6	R928053200	R928005926

63FLDK(N) preferred types, NBR seal, flow specifications for 30 mm²/s [143 SUS]

Duplex filter, filter rating 10 µm

Type	Flow in l/min [US gpm] with $\Delta p = 1$ bar [14.5 psi] ¹⁾	Material no. Filters				Material no. Replacement element
63FLDKN0063-1X/H10XLA00-V2,2-M-..	92 [24.30]	..S4	R928044480			R928005855
63FLDKN0100-1X/H10XLA00-V2,2-M-..	120 [31.70]	..S4	R928044481			R928005873
63FLDK0130-1X/H10XLA00-V2,2-M-..	220 [58.12]	..S6	R928044482			R928037180
63FLDK0150-1X/H10XLA00-V2,2-M-..	275 [72.65]	..S6	R928044483			R928037183
63FLDKN0160-1X/H10XLA00-V2,2-M-..	325 [85.86]	..S8	R928044484	..S6	R928053263	R928005891
63FLDKN0250-1X/H10XLA00-V2,2-M-..	440 [116.24]	..S8	R928044485	..S6	R928053262	R928005927

¹⁾ Measured pressure differential across filter and measuring equipment according to ISO 3968. The measured pressure differential at the maintenance indicator is lower.

Ordering code
Accessories (dimensions in mm [inch])

Electronic switching element for maintenance indicators

01	02	03
WE	-	-

Maintenance indicator

01	Electronic switching element	WE
----	------------------------------	-----------

Type of signal

02	1 switching point	1SP
	2 switching points, 3 LED	2SP
	2 switching points, 3 LED and signal suppression up to 30 °C [86 °F]	2SPSU

Connector

03	Round plug-in connection M12x1, 4-pole	M12x1
	Rectangular plug-in connector, 2-pole, design A according to EN-175301-803	EN175301-803

Material numbers of the electronic switching elements

Material no.	Type	Signal	Switching points	Connector	LED
R928028409	WE-1SP-M12x1	Changeover	1	M12x1	Without
R928028410	WE-2SP-M12x1	Normally open (at 75 %) / normally closed contact (at 100 %)	2		3 pieces
R928028411	WE-2SPSU-M12x1				
R928036318	WE-1SP- EN175301-803	Normally closed contact	1	EN 175301-803	Without

Mating connectors according to IEC 60947-5-2

For electronic switching element with round plug-in connection M12x1

Mating connector suitable for K24 4-pole, M12x1 with screw connection, cable gland Pg9.

Material no. R900031155

Mating connector suitable for K24-3m 4-pole, M12x1 with potted-in PVC cable, 3 m long.

Line cross-section: 4 x 0.34 mm²

Core marking: **1** Brown **2** White
 3 Blue **4** Black

Material no. R900064381

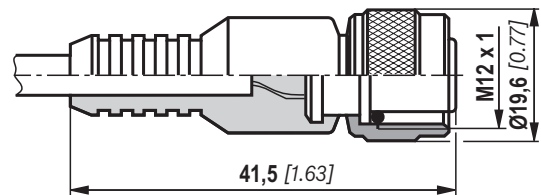
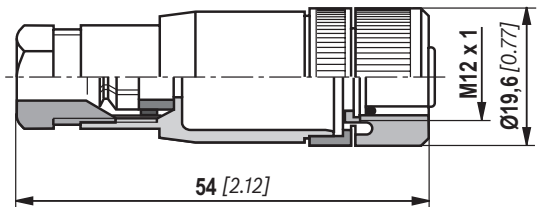

For more round plug-in connections and technical data refer to data sheet 08006.

Order example:

Duplex filter with mechanical optical maintenance indicator for $p_{Nominal} = 63 \text{ bar}$ [913 psi] with bypass valve, size 0100, with filter element 3 µm and electronic switching element M12x1 with 1 switching point for hydraulic fluid mineral oil HLP according to DIN 51524.

Filter:	63FLDKN0100-1X/H3XLA00-V2,2-M-S4	Material no: R928053187
Maintenance indicator:	WE-1SP-M12x1	Material no: R928028409
Mating connector:	Mating connector suitable for K24 4-pole, M12x1	Material no. R900031155

Symbols

Duplex filter with bypass valve and mechanical indicator as well as optional pressure equalization line

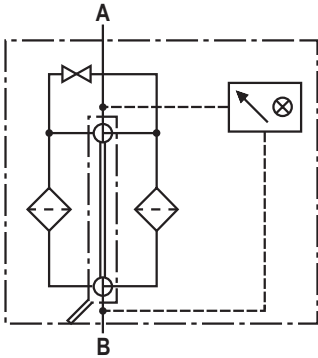
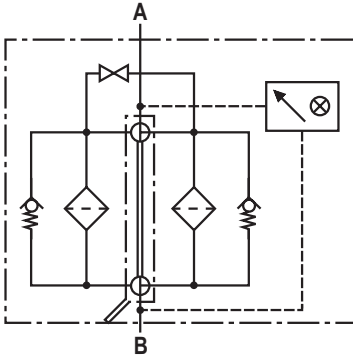

Pressure filter without bypass valve and with mechanical indicator as well as optional pressure equalization line

Electronic switching element for maintenance indicator

Switching element Connector

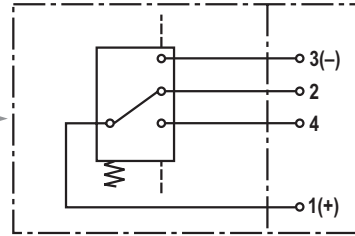

WE-1SP-M12x1

Switching element Connector

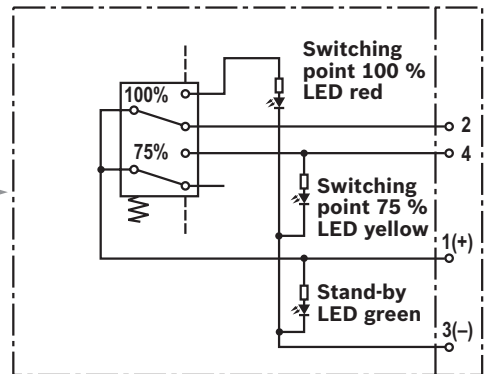

WE-2SP-M12x1

Circuit diagram drawn in plugged condition (operating state)

Switching element Connector

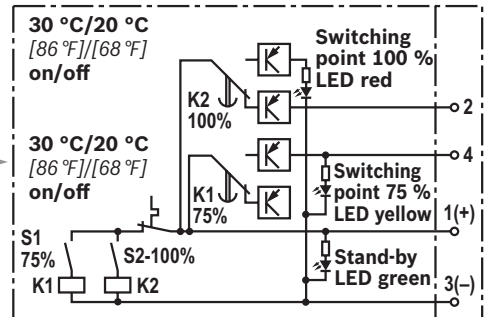

WE-2SPSU-M12x1

Circuit diagram drawn in plugged condition at temperature > 30 °C [86 °F] (operating state)

Function, section

The 63FLDK(N) duplex filter is suitable for inline installation.

It basically consists of two filter housings (2) with switch-over fitting (1), a threaded filter cover (3), filter element (4) as well as mechanical optical maintenance indicator (11).

Via the inlet, the hydraulic fluid reaches the filter element (4) where it is cleaned. The dirt particles filtered out collect in the filter element (4) and in the filter housing (2). Via the outlet, the filtered fluid enters the hydraulic circuit.

By means of the switching lever, you can switch between the two filter housings without operational interruption.

The filter housing and all connection elements are designed so that pressure peaks - as they may e.g. occur in case of abrupt opening of large control valves due to the accelerated fluid quantity - can be securely absorbed. One magnetic screw (8) is included in the standard equipment. The magnetic screw only collects magnetic contamination particles.

Via the bleed screws (standard) and/or bleed valves - amending ordering code E (7) -, the filter side to be maintained can be bled. The measuring ports (9) at the side of the connection flange are drilled as standard. Optionally, threaded couplings - amending ordering code M - can be ordered.

As an option, the filter is available with a base - amending ordering code FB - (10). The optional pressure equalization line (13) serves to simplify the filling and bleeding in a filter element exchange. The pressure equalization line is necessary in order to prevent unwanted aeration.

By default, the filter is equipped with mechanical optical maintenance indicator (11). The electronic switching element (12) which has to be ordered separately is attached to the mechanical optical maintenance indicator (11) and held by means of a locking ring. The electronic switching elements with 1 or 2 switching points are connected via a mating connector according to IEC-60947-5-2 or via a cable connection according to EN17301-803.

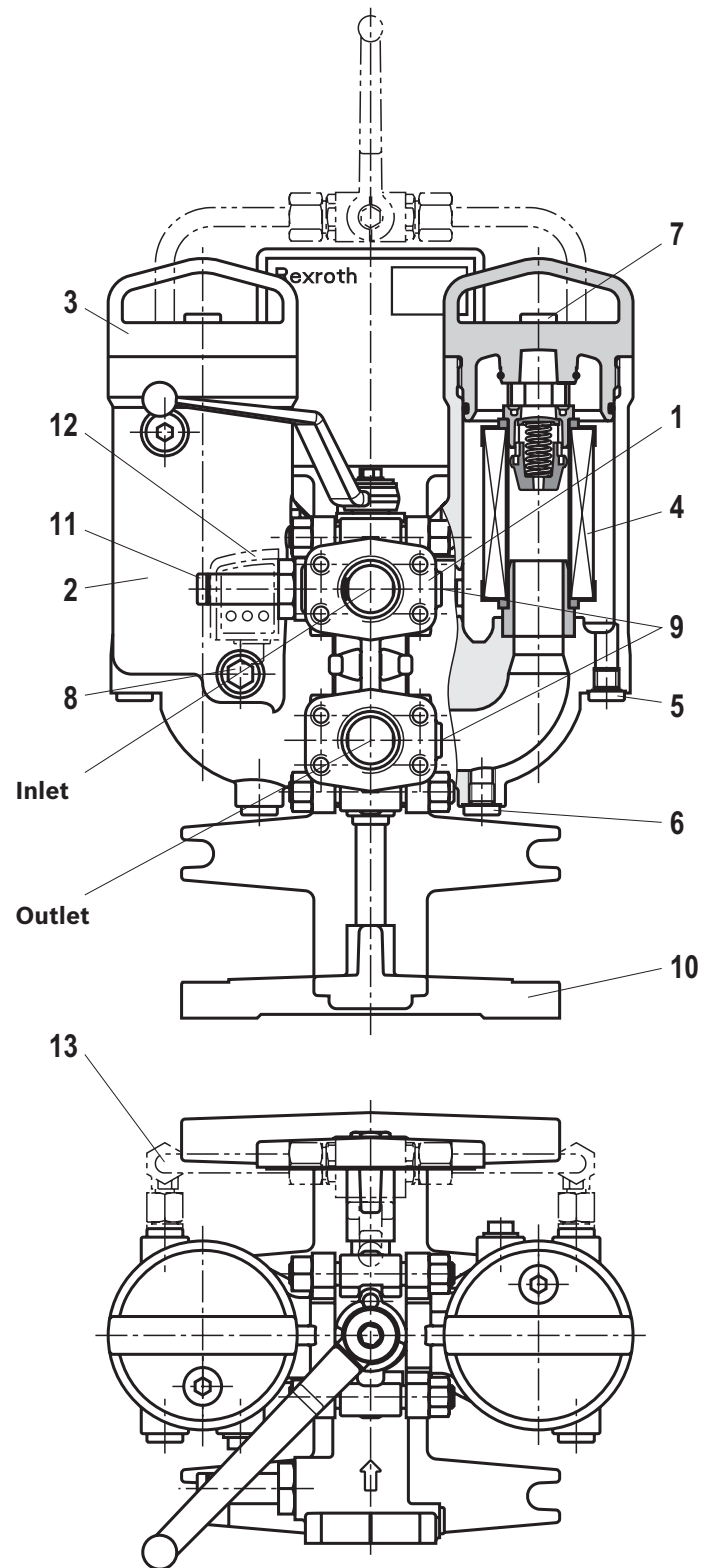

- 5 Draining dirt side
- 6 Draining clean side

WARNING!

If the maintenance indicator is ignored when an element change is required, there is the possibility the filter will go into bypass and contaminated oil will pass to the clean side of the filter outlet. Therefore the filtration effectiveness is no longer guaranteed.

Technical data

(For applications outside these parameters, please consult us!)

general				
Ambient temperature range	°C [°F]	-10 ... +65 [14 ... 149]; (shortly up to -30 [-22])		
Installation position		Vertical		
Weight	Size	0063	0100	0130
	kg [lbs]	23 [50.6]	26 [57.2]	33 [72.6]
	Size	0150	0160	0250
	kg [lbs]	36 [79.2]	64 [140.8]	69 [151.8]
Volume	Size	0063	0100	0130
	l	2 x 1.1	2 x 1.6	2 x 1.9
	[US gal]	2 x [0.29]	2 x [0.42]	2 x [0.5]
	Size	0150	0160	0250
l	2 x 2.6	2 x 3.3	2 x 4.5	
[US gal]	2 x [0.69]	2 x [0.87]	2 x [1.19]	
Material	- Filter cover	Ductile Iron		
	- Filter housing	Ductile Iron		
	- Bypass valve	Aluminum / steel / POM		
	- Seals	NBR or FKM		
	- Optical maintenance indicator	V0.8, V1.5, V2.2	Aluminum	
		V5.0	Brass	
- Electronic switching element		Plastic PA6		

hydraulic			
Maximum operating pressure	bar [psi]	63 [913]	
Hydraulic fluid temperature range	°C [°F]	-10 ... +100 [+14 ... +212]	
Minimum conductivity of the medium	pS/m	300	
Fatigue strength according to ISO 10771	Load cycles	> 10 ⁶ with operating pressure	
Type of pressure measurement of the maintenance indicator		Pressure differential	
Assignment: Response pressure of the maintenance indicator / cracking pressure of the bypass valve		Response pressure of the maintenance indicator	Cracking pressure of the bypass valve
	bar [psi]	0.8 ± 0.15 [11.6 ± 2.2]	3.5 ± 0.35 [50.8 ± 5.1]
		1.5 ± 0.2 [21.8 ± 2.9]	3.5 ± 0.35 [50.8 ± 5.1]
		2.2 ± 0.3 [31.9 ± 4.4]	3.5 ± 0.35 [50.8 ± 5.1]
		5.0 ± 0.5 [72.5 ± 7.3]	Only possible without bypass valve

Technical data

(For applications outside these parameters, please consult us!)

electric (electronic switching element)				
Electrical connection	Round plug-in connection M12x1, 4-pole			Standard connection EN 175301-803
	Version	WE-1SP- M12x1	WE-2SP- M12x1	WE-2SPSU- M12x1
Contact load, direct voltage	$A_{max.}$	1		
Voltage range	$V_{max.}$	150 (AC/DC)	10 ... 30 (DC)	250 (AC)/200 (DC)
Max. switching power with resistive load	W	20		
Switching type	– 75 % signal	–	Normally open contact	
	– 100 % signal	Changeover	Normally closed contact	
	– 2SPSU		Signal interconnection at 30 °C [86 °F], return switching at 20 °C [68 °F]	
Display via LEDs in the electronic switching element 2SP...		Stand-by (LED green); 75 % switching point (LED yellow) 100 % switching point (LED red)		
Protection class according to EN 60529		IP 67		
Ambient temperature range	°C [°F]	–25 ... +85 [–13 ... +185]		
For direct voltage above 24 V, spark extinguishing is to be provided for protecting the switching contacts.				
Weight	Electronic switching element: – with round plug-in connection M12x1	kg [lbs]	0.1 [0.22]	

Filter element				
Glass fiber material H...XL		Single-use element on the basis of inorganic fiber		
		Filtration ratio according to ISO 16889 up to $\Delta p = 5$ bar [72.5 psi]		Achievable oil cleanliness accord- ing to ISO 4406 [SAE-AS 4059]
Particle separation	H20XL	$\beta_{20(c)} \geq 200$		19/16/12 ... 22/17/14
	H10XL	$\beta_{10(c)} \geq 200$		17/14/10 ... 21/16/13
	H6XL	$\beta_{6(c)} \geq 200$		15/12/10 ... 19/14/11
	H3XL	$\beta_{5(c)} \geq 200$		13/10/8 ... 17/13/10
Admissible pressure differential	– A	bar [psi]	30 [435]	
	– C	bar [psi]	160 [2320]	

Compatibility with permitted hydraulic fluids

Hydraulic fluid	Classification	Suitable sealing materials	Standards
Mineral oil	HLP	NBR	DIN 51524
Bio-degradable	– insoluble in water	HETG	NBR
		HEES	FKM
	– soluble in water	HEPG	FKM
Flame-resistant	– water-free	HFDD, HFDR	FKM
	– containing water	HFAS	NBR
		HFAE	NBR
		HFC	NBR
			VDMA 24317



Important information on hydraulic fluids!

- For more information and data on the use of other hydraulic fluids, please refer to data sheet 90220 or contact us.
- **Flame-resistant - containing water:** Due to possible chemical reactions with materials or surface coatings of machine and system components, the service life with these hydraulic fluids may be less than expected. Filter materials made of

filter paper P... (cellulose) may not be used, filter elements with glass fiber material (HydroClean H...XL or wire mesh G) have to be used instead.

- **Bio-degradable:** If filter materials made of filter paper are used, the filter life may be shorter than expected due to material incompatibility and swelling.

Characteristic curves

(measured with mineral oil HLP46 according to DIN 51524)

H3XL

Spec. weight: < 0.9 kg/dm³

Δp -Q characteristic curves for complete filters

recommended initial Δp for design = 0.8 bar [11.6 psi]

Selection of the perfect filter is made possible by our online "Bosch Rexroth FilterSelect" design software.

Oil viscosity:

- 140 mm²/s [649 SUS]
- · - 68 mm²/s [315 SUS]
- - - 30 mm²/s [143 SUS]

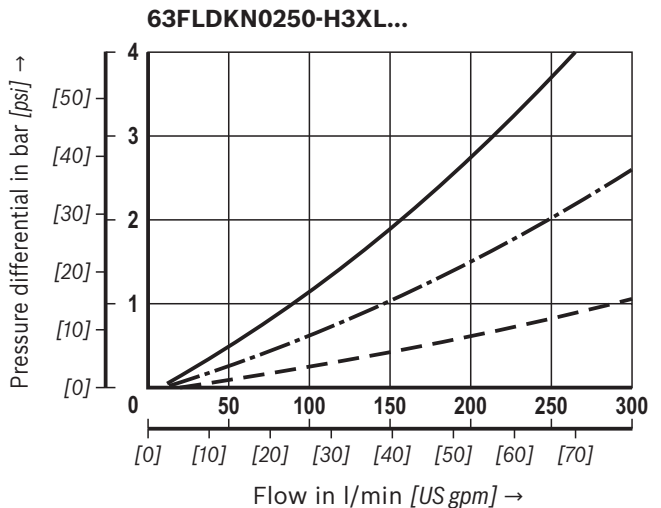
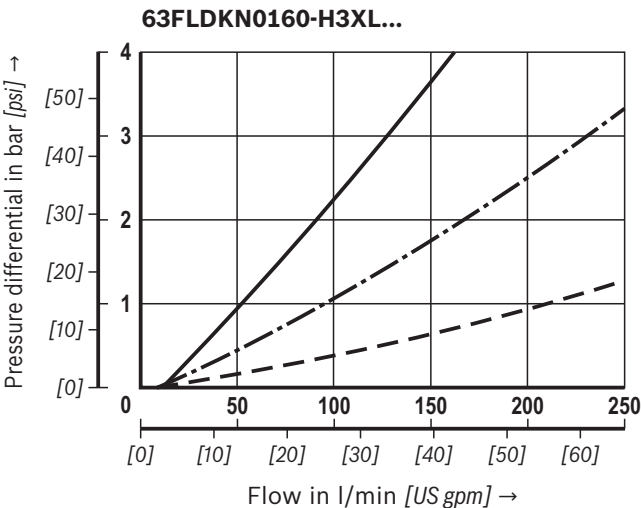
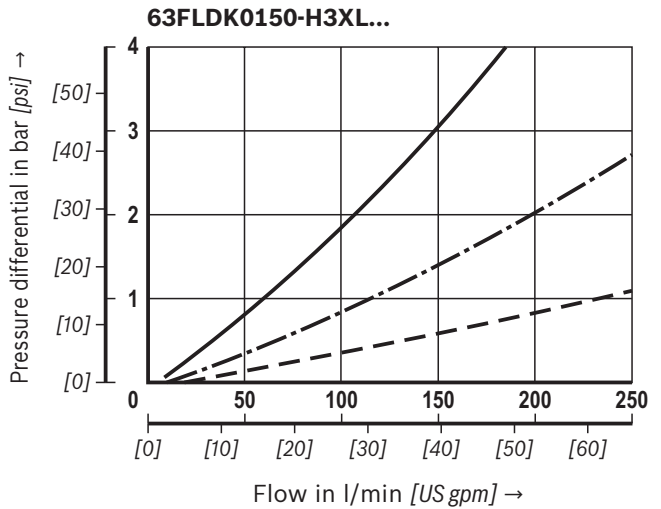
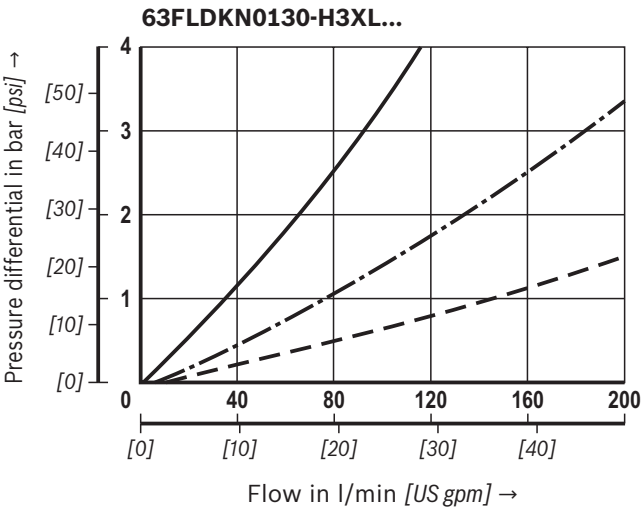
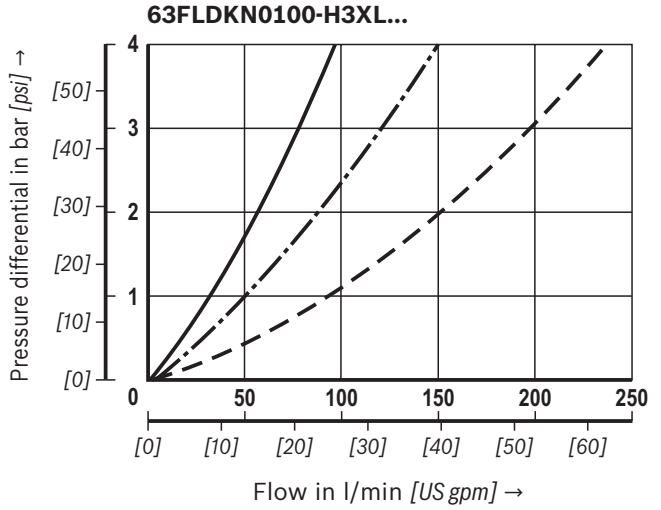
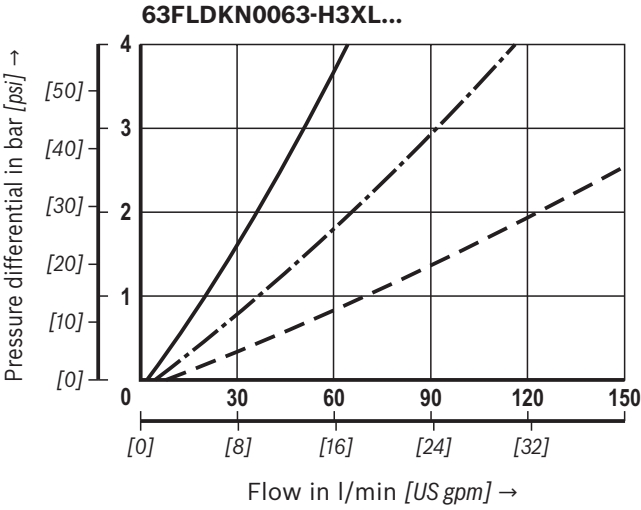

Characteristic curves

(measured with mineral oil HLP46 according to DIN 51524)

H10XL

Spec. weight: < 0.9 kg/dm³

Δp -Q characteristic curves for complete filters

recommended initial Δp for design = 0.8 bar [11.6 psi]

Selection of the perfect filter is made possible by our online "Bosch Rexroth FilterSelect" design software.

Oil viscosity:
 — 140 mm²/s [649 SUS]
 - · - 68 mm²/s [315 SUS]
 - - - 30 mm²/s [143 SUS]

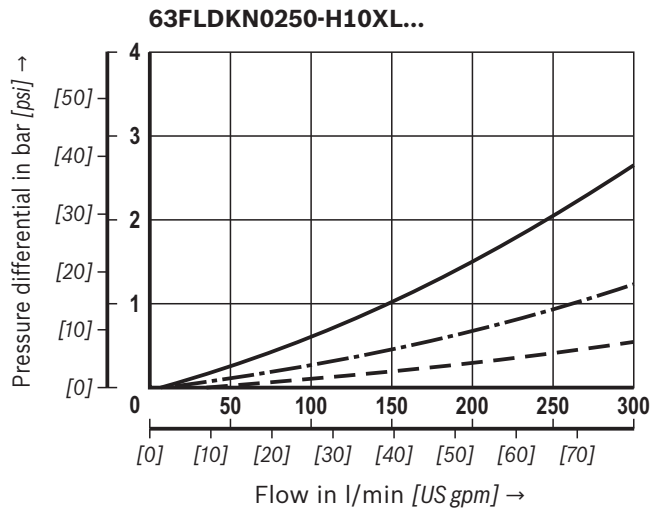
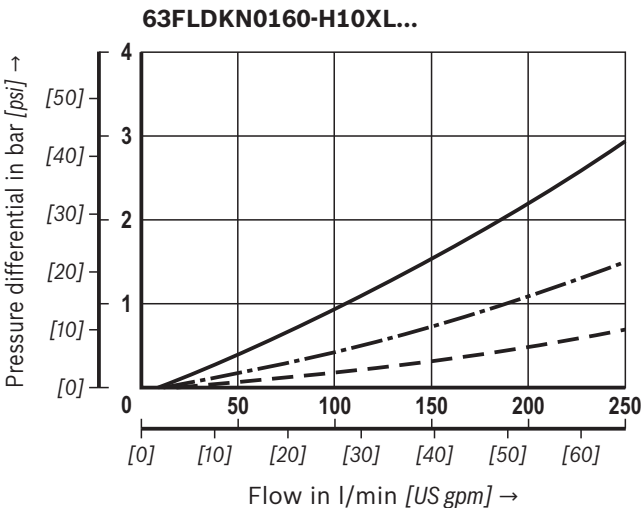
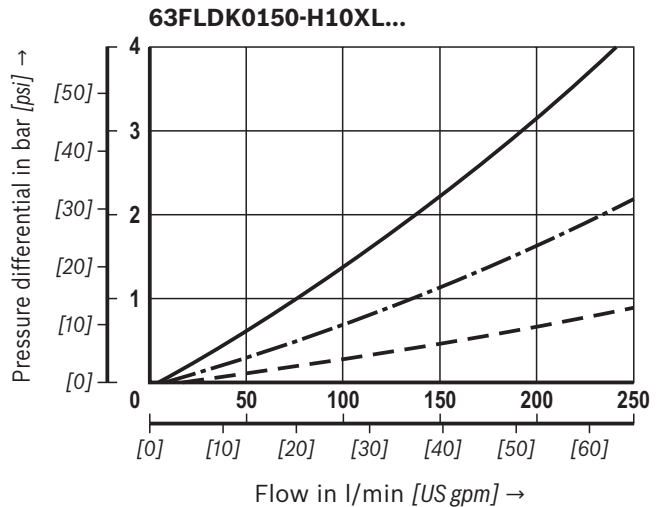
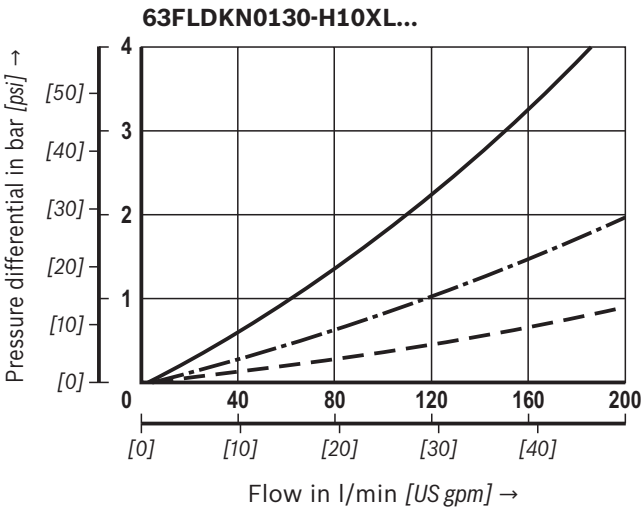
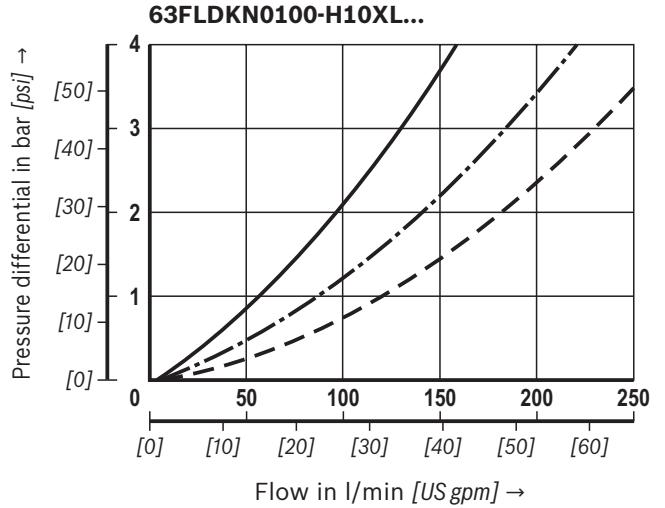
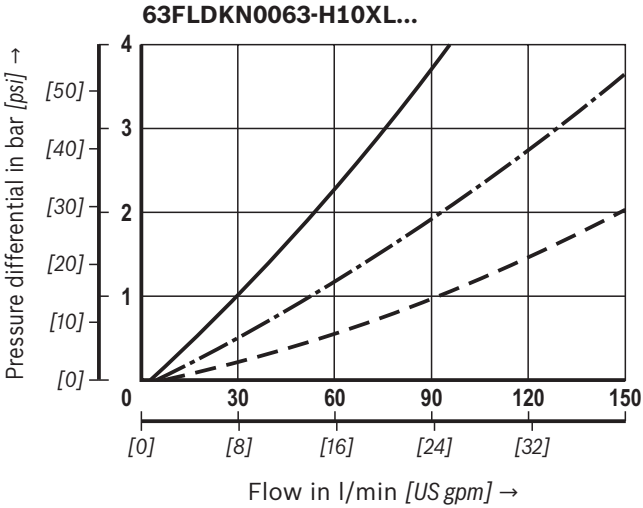

Unit dimensions: Size 0063 ... size 0250 with wall mounting
 (dimensions in mm [inch])

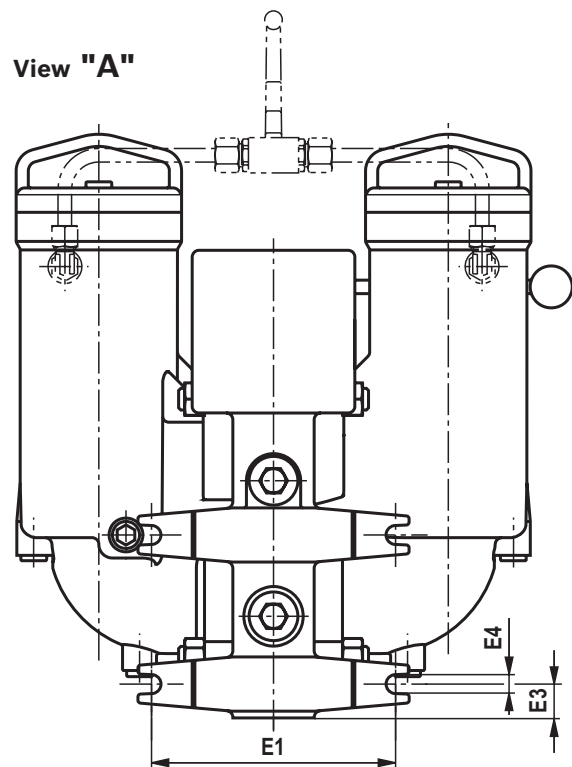
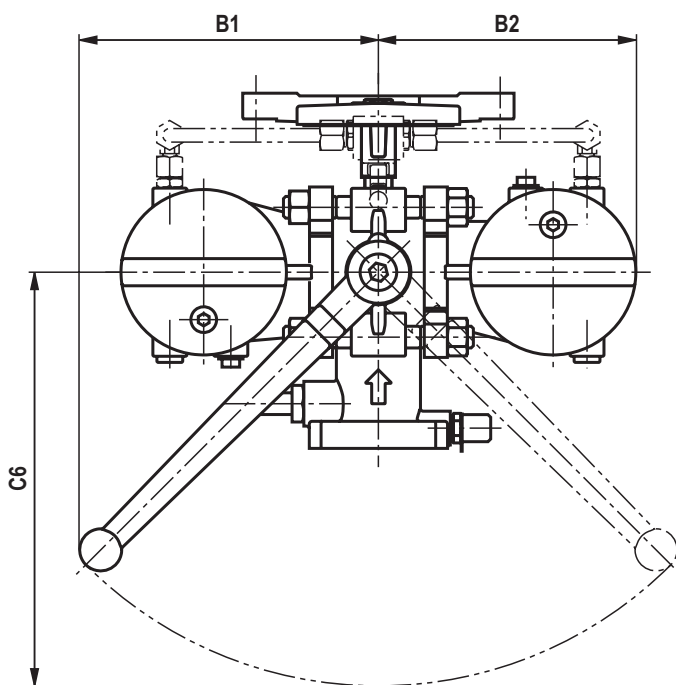
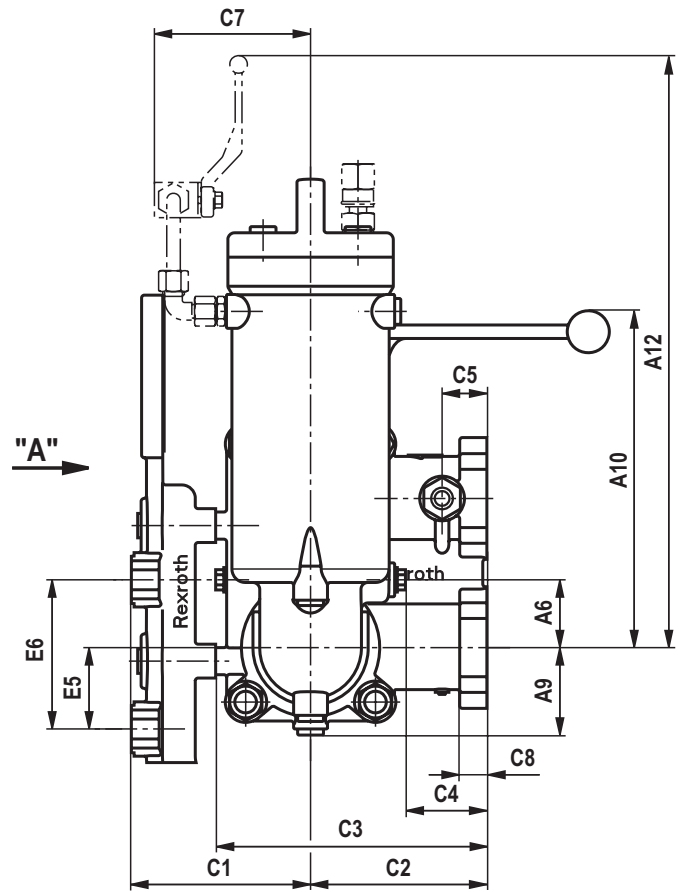
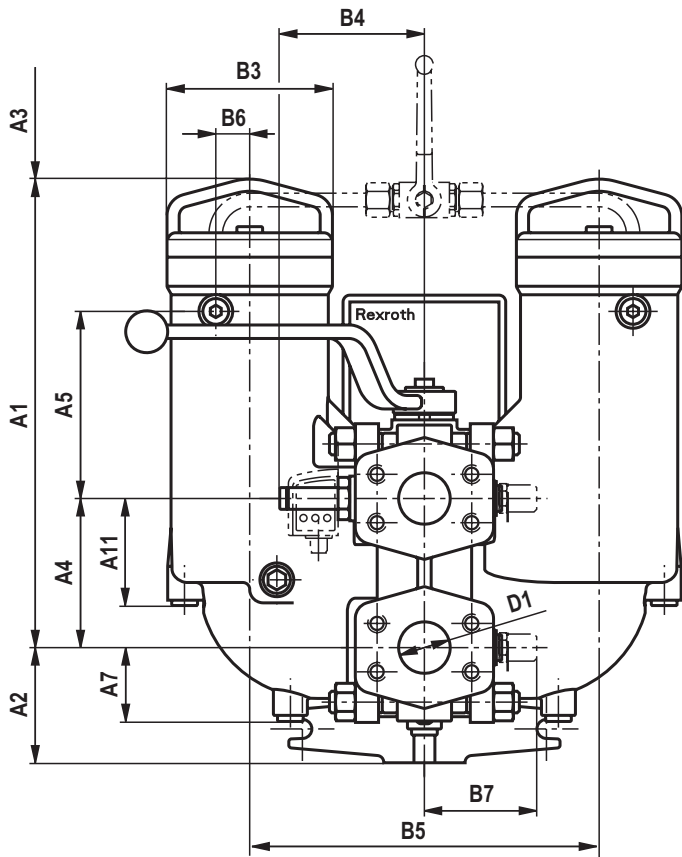

Unit dimensions: Size 0063 ... size 0250 with wall mounting
(dimensions in mm [inch])

With wall mounting	Lengths / heights											
	A1	A2	A3	A4	A5	A6	A7	A8	A9	A10	A11	A12
63 FLDKN 0063	315 [12.40]	85 [3.34]	160 [6.30]	80 [3.15]	143 [5.63]	35 [1.38]	39,5 [1.55]	-	44,5 [1.75]	189 [7.44]	59 [2.32]	406,5 [16.00]
63 FLDKN 0100	405 [15.94]		250 [9.84]		233 [9.17]							496,5 [19.55]
63 FLDK 0130	346 [13.62]		170 [6.69]	138 [5.43]	436,5 [17.18]							
63 FLDK 0150	436 [17.17]		260 [10.24]	228 [8.98]	526,5 [20.73]							
63 FLDKN 0160	370 [14.57]		160 [6.30]	135 [5.31]	456,5 [17.97]							
63 FLDKN 0250	460 [18.11]		250 [9.84]	225 [8.86]	546,5 [21.52]							

With wall mounting	Widths							Depths							
	B1	B2	ØB3	B4	B5	B6	B7	C1	C2	C3	C4	C5	C6	C7	C8
63 FLDKN 0063	120,5 [4.74]	139 [5.47]	100 [3.94]	92 [3.62]	178 [7.00]	20 [0.79]	66 [2.60]	112 [4.40]	110 [4.33]	160 [6.30]	50 [1.97]	29 [1.14]	168 [6.61]	105 [4.13]	16 [0.62]
63 FLDK 0130	220 [8.66]	190 [7.48]	122 [4.80]	107 [4.21]	258 [10.15]	25 [0.98]	115 [4.53]	132 [5.19]	130 [5.12]	200 [7.87]	60 [2.36]	33 [1.30]	305 [12.01]	115 [4.53]	20 [0.79]
63 FLDK 0150		226 [8.90]	155 [6.10]			30 [1.18]								130 [5.12]	
63 FLDKN 0160		226 [8.90]	155 [6.10]	30 [1.18]	130 [5.12]	130 [5.12]	130 [5.12]								
63 FLDKN 0250		226 [8.90]	155 [6.10]	30 [1.18]	130 [5.12]	130 [5.12]	130 [5.12]								

With wall mounting	Wall mounting						
	Port D1	E1	E2	E3	E4	E5	E6
	S...						
63 FLDKN 0063	SAE 1"	180 [7.09]	-	25 [0.98]	14 [0.55]	60 [2.36]	110 [4.33]
63 FLDKN 0100	3000 psi						
63 FLDK 0130	SAE 1 1/2"	180 [7.09]	-	25 [0.98]	14 [0.55]	60 [2.36]	110 [4.33]
63 FLDK 0150	3000 psi						
63 FLDKN 0160	SAE 2"	180 [7.09]	-	25 [0.98]	14 [0.55]	60 [2.36]	110 [4.33]
63 FLDKN 0250	3000 psi						

Unit dimensions: Size 0063 ... size 0250 with floor mounting
 (dimensions in mm [inch])

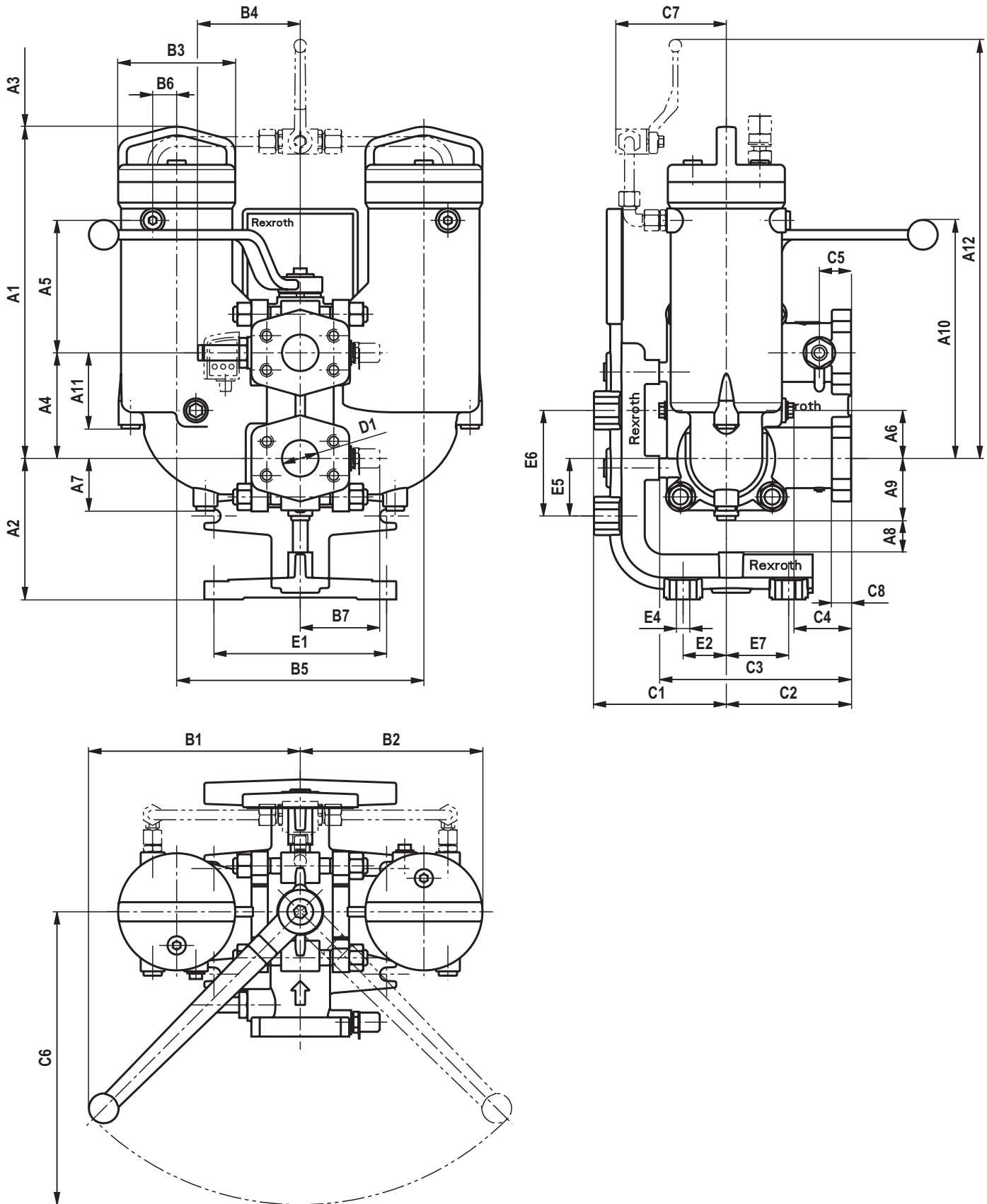

Unit dimensions: Size 0063 ... size 0250 with floor mounting
(dimensions in mm [inch])

With foot mounting	Lengths / heights											
	A1	A2	A3	A4	A5	A6	A7	A8	A9	A10	A11	A12
63 FLDKN 0063...-FB	315 [12.40]	147 [5.79]	160 [6.30]	80 [3.15]	143 [5.63]	35 [1.38]	39,5 [1.55]	53,5 [2.11]	44,5 [1.75]	189 [7.44]	59 [2.32]	406,5 [16.00]
63 FLDKN 0100...-FB	405 [15.94]		250 [9.84]		233 [9.17]							496,5 [19.55]
63 FLDK 0130...-FB	346 [13.62]		170 [6.69]	110 [4.33]	138 [5.43]	50 [1.97]	54,5 [2.15]	33,5 [1.32]	64,5 [2.53]	249 [9.80]	79 [3.11]	436,5 [17.18]
63 FLDK 0150...-FB	436 [17.17]		260 [10.24]		228 [8.98]							526,5 [20.73]
63 FLDKN 0160...-FB	370 [14.57]		160 [6.30]		135 [5.31]							456,5 [17.97]
63 FLDKN 0250...-FB	460 [18.11]		250 [9.84]		225 [8.86]							546,5 [21.52]

With foot mounting	Widths							Depths							
	B1	B2	ØB3	B4	B5	B6	B7	C1	C2	C3	C4	C5	C6	C7	C8
63 FLDKN 0063...-FB	120,5 [4.74]	139 [5.47]	100 [3.94]	92 [3.62]	178 [7.00]	20 [0.79]	66 [2.60]	118 [4.65]	110 [4.33]	160 [6.30]	50 [1.97]	29 [1.14]	168 [6.61]	105 [4.13]	16 [0.62]
63 FLDK 0130...-FB	220 [8.66]	190 [7.48]	122 [4.80]	107 [4.21]	258 [10.15]	25 [0.98]	115 [4.53]	138 [5.43]	130 [5.12]	200 [7.87]	60 [2.36]	33 [1.30]	305 [12.01]	115 [4.53]	20 [0.79]
63 FLDK 0150...-FB		226 [8.90]	155 [6.10]			30 [1.18]								130 [5.12]	
63 FLDKN 0160...-FB		226 [8.90]	155 [6.10]	30 [1.18]	130 [5.12]										
63 FLDKN 0250...-FB		226 [8.90]	155 [6.10]	30 [1.18]	130 [5.12]										

With foot mounting	Foot mounting							
	Port D1	E1	E2	E3	E4	E5	E6	E7
	S...							
63 FLDKN 0063...-FB	SAE 1"	180 [7.09]	25 [0.98]	-	14 [0.55]	60 [2.36]	110 [4.33]	65 [2.55]
63 FLDKN 0100...-FB	3000 psi		45 [1.77]					85 [3.34]
63 FLDK 0130...-FB	SAE 1 1/2"	180 [7.09]	45 [1.77]	-	14 [0.55]	60 [2.36]	110 [4.33]	85 [3.34]
63 FLDK 0150...-FB	3000 psi							
63 FLDKN 0160...-FB	SAE 2"							
63 FLDKN 0250...-FB	3000 psi							

Maintenance indicator (dimensions in mm [inch])

**Pressure differential indicator
with mounted switching element M12x1**

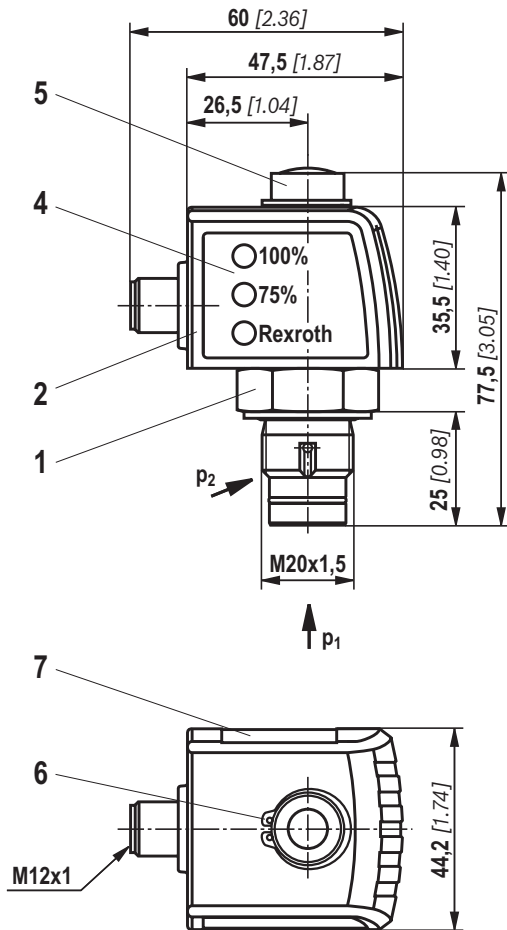

**Pressure differential indicator
with mounted switching element EN-175301-803**

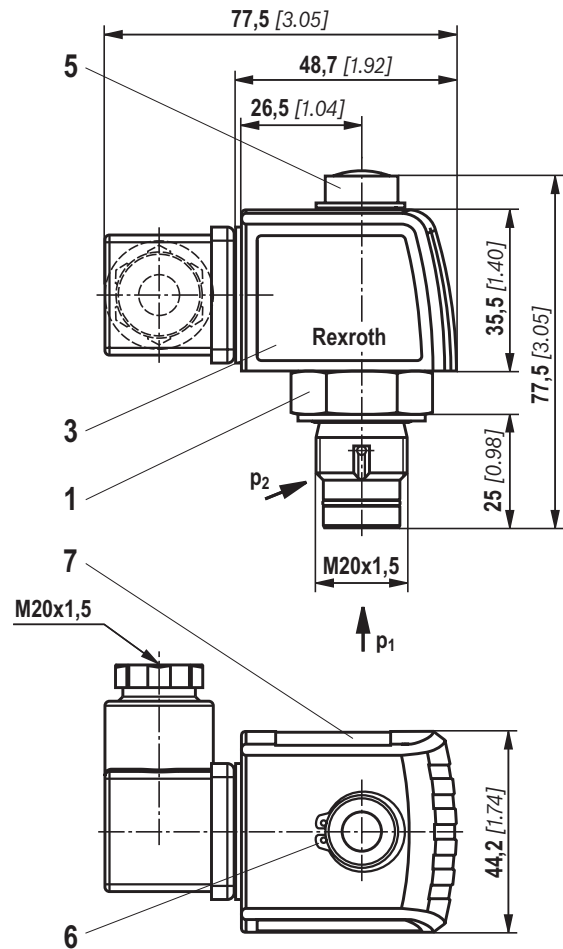

- 1 Mechanical optical maintenance indicator;
Max. tightening torque $M_{A \max} = 50 \text{ Nm}$ [36.88 lb-ft]
- 2 Switching element with locking ring for
electrical maintenance indicator (rotatable by 360°);
round plug-in connection M12x1, 4-pole
- 3 Switching element with locking ring for
electrical maintenance indicator (rotatable by 360°);
rectangular plug-in connection EN175301-803
- 4 Housing with three LEDs: 24 V =
Green: Stand-by
Yellow: Switching point 75 %
Red: Switching point 100 %
- 5 Visual indicator with memory function
- 6 Locking ring DIN 471-16x1,
material no. R900003923
- 7 Name plate

Notices:

Representation contains mechanical optical maintenance indicator (1) and electronic switching element (2).

Ordering code Spare parts

Filter element

01	02	03	04	05	06
1.			-	-	0

Filter element

01	Design	1.
----	--------	----

Size

02	FLDKN...	0063 0100 0160 0250
	FLDK...	0130 0150

Filter rating in µm

03	Nominal	Stainless steel wire mesh, cleanable	G10 G25 G40 G60 G100
		Paper, not cleanable	P10 P25
	Absolute (ISO 16889)	Glass fiber material, not cleanable	H3XL H6XL H10XL H20XL

Pressure differential

04	Maximum admissible pressure differential of the filter element 30 bar [435 psi]	A00
	Maximum admissible pressure differential of the filter element 160 bar [2320 psi], without bypass valve	C00

Bypass valve

05	Without bypass valve	0
----	----------------------	---

Seal

06	NBR seal	M
	FKM seal	V

Order example:

1.0100 H3XL-A00-0-M

For detailed information on Rexroth filter elements please refer to data sheet 51420.

Preferred program replacement elements

Filter element type	Filter material/material no.		
	H3XL	H6XL	H10XL
1.0063 ...A00-0-M	R928005853	R928005854	R928005855
1.0100 ...A00-0-M	R928005871	R928005872	R928005873
1.0130 ...A00-0-M	R928037178	R928045104	R928037180
1.0150 ...A00-0-M	R928037181	R928037182	R928037183
1.0160 ...A00-0-M	R928005889	R928005890	R928005891
1.0250 ...A00-0-M	R928005925	R928005926	R928005927

Ordering code**Spare parts****Mechanical optical maintenance indicator**

01 02 03 04 05 06

W	O	-	D01	-		-		-	
----------	----------	---	------------	---	--	---	--	---	--

01	Maintenance indicator	W
02	Mechanical visual indicator	O
03	Design pressure differential M20x1.5	D01

Switching pressure

04	0.8 bar [11.6 psi]	0.8
	1.5 bar [21.8 psi]	1.5
	2.2 bar [31.9 psi]	2.2
	5.0 bar [72.5 psi]	5.0

Seal

05	NBR seal	M
	FKM seal	V

Max. nominal pressure

06	Switching pressure 0.8 bar [11.6 psi], 160 bar [2321 psi]	160
	Switching pressure 1.5 bar [21.8 psi], 160 bar [2321 psi]	160
	Switching pressure 2.2 bar [31.9 psi], 160 bar [2321 psi]	160
	Switching pressure 5.0 bar [72.5 psi], 450 bar [6527 psi]	450

Mechanical optical maintenance indicator	Material no.
WO-D01-0,8-M-160	R928038779
WO-D01-1,5-M-160	R928038781
WO-D01-2,2-M-160	R901025312
WO-D01-5,0-M-450	R901025313
WO-D01-0,8-V-160	R928038778
WO-D01-1,5-V-160	R928038780
WO-D01-2,2-V-160	R901066233
WO-D01-5,0-V-450	R901066235

Ordering code Spare parts

Seal kit

01	02	03	04	05
D	63FLDK		- 1X / -	

01	Seal kit	D
02	Series	63FLDK

Size

03	Size 0063-0100	N0063-0100
	Size 0130-0150	0130-0150
	Size 0160-0250	N0160-0250
04	Component series 10 ... 19 (10 ... 19: Unchanged installation and connection dimensions)	1X

Seal

05	NBR seal	M
	FKM seal	V

Seal kit	Material no.
D63FLDKN0063-0100-1X/-M	R928053202
D63FLDK=0130-0150-1X/-M	R928053203
D63FLDKN0160-0250-1X/-M	R928053204
D63FLDKN0063-0100-1X/-V	R928053205
D63FLDK0130-0150-1X/-V	R928053206
D63FLDKN0160-0250-1X/-V	R928053207

Notice:

Seals of the switch-over are not included in the filter seal kit. In case of leakage at the switch-over, please contact the Rexroth Service.

Assembly, commissioning, maintenance

Assembly

The max. operating pressure of the system must not exceed the max. admissible Do not exceed the operating pressure of the filter (see name plate).

In the assembly, you have to distinguish between floor mounting and wall mounting.

During assembly of the filter (see also chapter "Tightening torques"), the flow direction (direction arrows) and the required servicing height of the filter element (see chapter "Dimensions") are to be considered. The filter cover may be used as lifting point.

(See information on the name plate).

Proper function is only guaranteed in the installation position filter cover vertically upwards. The maintenance indicator must be arranged so it is easily viewed in operation.

Remove the plastic plugs in the filter inlet and outlet.

Ensure that the system is assembled without tension stress.

The optional electronic maintenance indicator is connected via the electronic switching element with 1 or 2 switching points, which is attached to the mechanical optical maintenance indicator and held by means of the locking ring.

Commissioning

Bring the switching lever into central position in order to fill both filter sides.

Start the system.

Bleed filter by opening the bleed screws or bleed valves, close when operating liquid begins to escape.

Switch the filter into the operating position; to do so, switch the switching lever to one of the two end positions. (See information on the name plate).

The switch-over lever is on the filter side that is in operation.

Open the optional pressure equalization line.

Maintenance

- ▶ If at operating temperature, the red indicator pin reaches out of the mechanical optical maintenance indicator and/or if the electronic switching element opens/closes the circuit, the filter element is contaminated and needs to be replaced or cleaned respectively.
- ▶ The material number of the corresponding replacement filter element is indicated on the name plate of the complete filter.

It must correspond to with the material number on the filter element.

- ▶ The switch-over lever is on the filter side that is in operation. (See information on the name plate).
- ▶ Switch the filter over.
- ▶ Close the optional pressure equalization valve.
- ▶ Open the bleed screw or bleed valve at the decommissioned filter side in order to reduce the pressure.
- ▶ Via the drain screw, the oil on the dirt side can be drained.
- ▶ Unscrew the filter cover of the filter side that is not in operation.
- ▶ Remove the filter element from the spigot by rotating it slightly.
- ▶ Where appropriate, remove the magnetic screw and check it for magnetic residue.
- ▶ Clean the filter components, if necessary.
- ▶ Check the seals for damage and replace them, if necessary.
For suitable seal kits refer to chapter "Spare parts".
- ▶ Filter elements made of wire mesh can be cleaned.
For detailed cleaning instructions refer to data sheet 51420.
- ▶ Install the new or cleaned filter element on the spigot again by slightly rotating it.
- ▶ The filter is to be assembled in reverse order.
- ▶ The torque specifications ("Tightening torques" chapter) are to be observed.

Moreover required for filters with pressure equalization line (optional)

- ▶ To fill the maintained filter side, open the pressure equalization line.
- ▶ The filter is bled via the bleed screw or the bleed valve which is still open.
- ▶ After fluid escapes, close the bleed screw or the bleed valve again.
- ▶ Ensure correct position of the switch-over lever end position.
- ▶ The pressure equalization valve should remain open.



Notice:

The switch over ball valve may only be disassembled by Rexroth service personnel.

Assembly, commissioning, maintenance

Correct position of the switching lever during filter element exchange

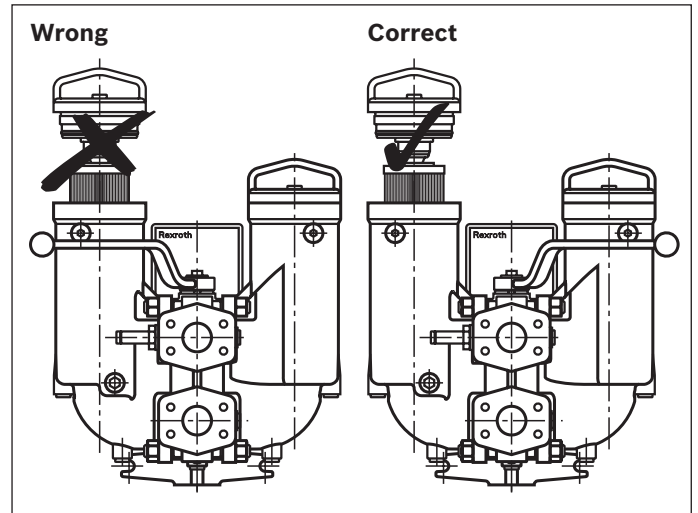
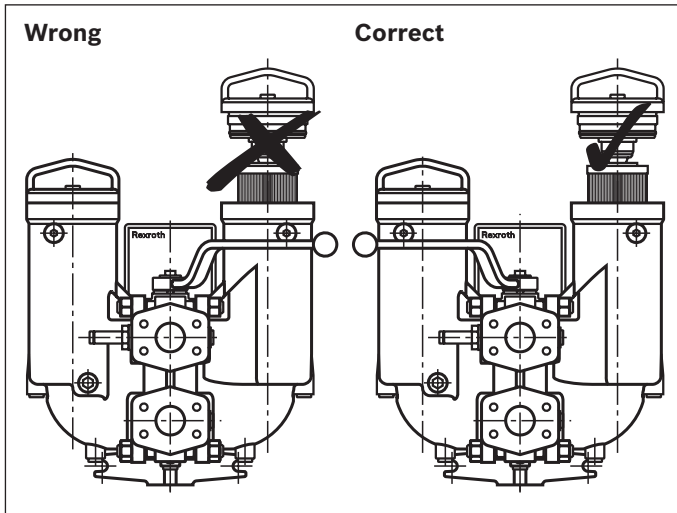

WARNINGS!

- ▶ Assemble and disassemble only with depressurized system! For the filter element exchange refer to "Maintenance".
 - ▶ Tank is pressurized!
 - ▶ All works at the filter only be trained specialists.
 - ▶ Remove the filter cover only if it is depressurized!
 - ▶ Do not exchange the optical/mechanical maintenance indicator while the filter is under pressure!
 - ▶ Do not operate the switching lever and the optional pressure equalization valve during the filter element exchange.
- ▶ When disassembling the filter, it has to be ensured that the system is depressurized.
 - ▶ Warranty is only guaranteed if original Bosch Rexroth filter elements and spare parts are used.
 - ▶ Warranty becomes void if the delivered item is changed by the ordering party or third parties or improperly mounted, installed, maintained, repaired, used or exposed to environmental condition that do not comply with the installation conditions.

Tightening torques

(dimensions in mm [*inch*])

Wall mounting

Series 63...	FLDKN0063	FLDKN0100	FLDK0130	FLDK0150	FLDKN0160	FLDKN0250
Screw/tightening torque with $\mu_{\text{total}} = 0.14$	M12 / 37 Nm \pm 10 % [27 lb-ft +/- 10%]					
Quantity	4					
Recommended property class of screw	8.8					
Minimum screw-in depth	15 [0.59]					

Foot mounting

Series 63...	FLDKN0063	FLDKN0100	FLDK0130	FLDK0150	FLDKN0160	FLDKN0250
Screw/tightening torque with $\mu_{\text{total}} = 0.14$	M12 / 37 Nm \pm 10 % [27 lb-ft +/- 10%]					
Quantity	4					
Recommended property class of screw	8.8					
Minimum screw-in depth	15 [0.59]					

Filter cover and maintenance indicator

Series 63...	FLDKN0063	FLDKN0100	FLDK0130	FLDK0150	FLDKN0160	FLDKN0250
Filter cover (2 x 1 piece)	Screw in to stop					
Tightening torque optical/mechanical maintenance indicator	50 Nm max [37 lb-ft max]					
Tightening torque cubic connector screw switching element EN-175301-803	M3 / 0.5 Nm [0.4 lb-ft +/- 10%]					

Directives and standardization

Classification according to the Pressure Equipment Directive

The duplex filters for hydraulic applications according to 51445 are pressure holding equipment according to article 1, section 2.1.4 of the Pressure Equipment Directive 97/23/EC (PED). However, based on the exception in

article 1, section 3.6 of the PED, hydraulic filters are exempt from the PED if they are not classified higher than category I (guideline 1/19).

They do not receive a CE mark.

Use in explosive areas according to directive 94/9/EC (ATEX)

The duplex filters according to 51445 are not equipment or components in the sense of directive 94/9/EC and are not provided with a CE mark. It has been proven with the ignition risk analysis that these inline filters do not have own ignition sources acc. to DIN EN 13463-1:2009.

According to DIN EN 60079-11:2012, the electronic maintenance indicators WE-1SP-M12x1 and WE-1SP-EN175301-803 are simple, electronic operating equipment not having an own voltage source. This simple, electronic operating equipment may - according to DIN EN 60079-14:2012 - in intrinsically

safe electric circuits (Ex ib) be used in systems without marking and certification.

The duplex filters and the electronic maintenance indicators described here can be used for the following explosive areas:

	Zone suitability	
Gas	1	2
Dust	21	22

Directives and standardization

Complete filter with mech./opt. Maintenance indicator			
Use /assignment		Gas 2G	Dust 2D
Assignment		Ex II 2G c IIB TX	Ex II 2D c IIB TX
Conductivity of the medium	pS/m	Min	300
Dust accumulation		Max	-
			0.5 mm

Electronic switching element in the intrinsically safe electric circuit			
Use /assignment		Gas 2G	Dust 2D
Assignment		Ex II 2G Ex ib IIB T4 Gb	Ex II 2D Ex ib IIIC T100 °C Db
Adm. intrinsically safe electric circuits		Ex ib IIC, Ex ic IIC	Ex ib IIIC
Technical data		Values only for intrinsically safe electric circuit	
Switching voltage	Ui	Max	150 V AC/DC
Switching current	Ii	Max	1.0 A
Switching power	Pi	Max	1.3 W T4 T _{max} 40 °C
		Max	1.0 W T4 T _{max} 80 °C
Surface temperature ¹⁾		Max	-
			100 °C
Inner capacity	Ci		Neglectable
Inner inductivity	Li		Neglectable
Dust accumulation		Max	-
			0.5 mm

¹⁾ The temperature depends on the temperature of the medium in the filter and must not exceed the value specified here.

Possible circuit according to DIN EN 60079-14

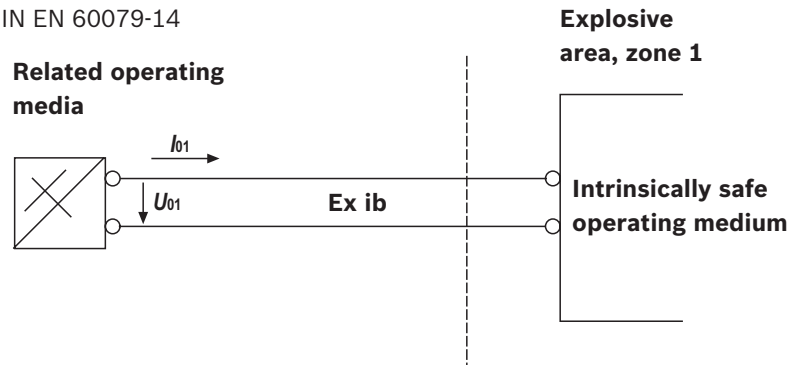

⚠ WARNING!

- ▶ Explosion hazard due to high temperature!
The temperature depends on the temperature of the medium in the hydraulic circuit and must not exceed the value specified here. Measures are to be taken so that in the explosive area, the max. admissible ignition temperature is not exceeded.
- ▶ When using the duplex filters according to 51445 in explosive areas, sufficient potential equalization has to be ensured. The filter is preferably to be grounded via the mounting screws.

It has to be noted in this connection that paintings and oxidic protective layers are not electrically conductive.

- ▶ Maintenance only by specialists, instruction by the machine end-user acc. to DIRECTIVE 1999/92/EC appendix II, section 1.1
- ▶ During filter element exchanges, the packaging material is to be removed from the replacement element outside the explosive area
- ▶ Functional and safety warranty only applicable when using genuine Rexroth spare parts

Notes

Bosch Rexroth AG
Werk Ketsch
Hardtwaldstrasse 43
68775 Ketsch, Germany
Phone +49 (0) 62 02 / 6 03-0
filter-support@boschrexroth.de
www.boschrexroth.de

© This document, as well as the data, specifications and other information set forth in it, are the exclusive property of Bosch Rexroth AG. It may not be reproduced or given to third parties without its consent.
The data specified above only serve to describe the product. No statements concerning a certain condition or suitability for a certain application can be derived from our information. The information given does not release the user from the obligation of own judgment and verification.
It must be remembered that our products are subject to a natural process of wear and aging.