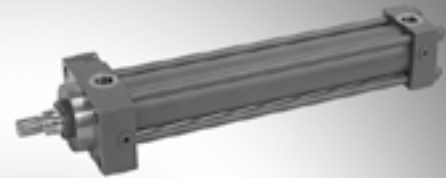

Hydraulic cylinders

Tie rod design

RE 17049/11.16
Replaces: 07.13

1/68

Series CDT3...Z; CGT3...Z; CST3...ZComponent series 3X
Nominal pressure 160 bar (16 MPa)

S1_d

Table of contents

Contents	Page	Contents	Page
Features	2	Piston rod end E and T	44
Technical data	2 ... 3	Position measurement system	45, 46
Information on stroke length and stroke velocity	4	Swivel head (clampable): CGKA - AP 6	47
Project planning software ICS	4	Clevis bracket (clampable): CLCB - AB 5	48, 49
Areas, forces, flow: Series CDT3	5	Trunnion bearing block CLTA - AT 4	50, 51
Overview types of mounting: Series CDT3	6	Kinking, admissible stroke length	52 ... 55
Ordering code: Series CDT3	7	End position cushioning, calculation example	56 ... 60
Areas, forces, flow: Series CGT3	8	Selection criteria for seals	61
Overview types of mounting: Series CGT3	8	Seal kits	62, 63
Ordering code: Series CGT3	9	Tightening torques	63
Dimensions: Types of mounting CDT3 / CGT3	10 ... 27	Spare parts: Series CDT3	64
Areas, forces, flow: Series CST3	28	Spare parts: Series CGT3	65
Overview types of mounting: Series CST3	28	Spare parts: Series CST3	66
Ordering code: Series CST3	29	Weight for cylinder	67, 68
Dimensions: Types of mounting CST3	30 ... 39		
Leakage oil connection / Enlarged line connection	40		
Position of line connections / bleeding / leakage oil / throttle valve	41		
Bleeding / threaded coupling	42		
Subplates – Dimensions and porting pattern	43, 44		

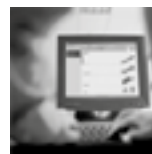
Project planning software **Interactive Catalog System****Online**www.boschrexroth.com/ics

Features

- Installation dimensions according to ISO 6020-2, DIN 24554 and NF/ISO 6020-2
- 13 types of mounting
- Piston Ø (**ØAL**): 25 to 200 mm
- Piston rod Ø (**ØMM**): 12 to 140 mm
- Stroke lengths up to 3000 mm
- Integrated guide socket for fast and easy maintenance
- Self-adjusting or adjustable end position cushioning as option
- Patented safety bleeding device for easy and safe bleeding
- Easy assembly thanks to freely selectable position of the line connections at head and base

Technical data (For applications outside these parameters, please consult us!)

Nominal pressure: 160 bar (16 MPa)

Maximum operating pressure
(only static load): 210 bar (21 MPa)

Static test pressure: 240 bar (24 MPa)

Cylinders of this series are designed for a nominal pressure of 160 bar and in version CD for a maximum operating pressure of 210 bar with static load.

(Static load: less than 10,000 load cycles over the entire life cycle)

The admissible dynamic operating pressure amounts to 75 % of the maximum operating pressure with maximum amplitude and oscillatory load.

The specified operating pressures apply to applications with shock-free operation with reference to excess pressure and/or external loads. With extreme loads like e. g. high sequence cycle, mounting elements and threaded piston rod connections must be designed for durability.

Minimum pressure:

Depending on the application, application conditions and technical design, a certain minimum pressure is required in order to guarantee technically unobjectionable functioning of the hydraulic cylinder.

Without load, we recommend complying with a minimum operating pressure of 10 bar. For lower pressures, please contact us.

Installation position: any

Hydraulic fluid (amending data sheet):

Mineral oils DIN 51524 HL, HLP (R. 90220)

Oil-in-water emulsion HFA (R. 90223)

Water glycol HFC (R. 90223)

Phosphate ester HFD-R (R. 90222)

Hydraulic fluid temperature range: see page 61

Ambient temperature range: see page 61

Optimum viscosity range: 20 to 100 mm²/s

Minimum admissible viscosity: 2.8 mm²/s

Maximum admissible viscosity: 380 mm²/s

Cleanliness class according to ISO

Maximum admissible degree of contamination of the hydraulic fluid according to ISO 4406 (c) class 20/18/15.

The cleanliness classes specified for the components need to be met in hydraulic systems. Effective filtration prevents faults and simultaneously increases the life cycle of the components.

For the selection of the filters see www.boschrexroth.com/ filter

Bleeding: By default

Primer coat: By default, hydraulic cylinders are primed with a coating (color gentian blue RAL 5010) of min. 40 µm. Other colors upon request.

With cylinders and attachment parts, the following surfaces are not primed or painted:

- All fit diameters to the customer side
- Sealing surfaces for line connection
- Sealing surfaces for flange connection
- Connection surface for valve mounting
- Position measurement system

The areas that are not painted are protected by means of a solvent-free corrosion protection agent.

Accessories that are ordered as separate order item are not primed or painted by default. Corresponding priming and/or painting on request.

Technical data (For applications outside these parameters, please consult us!)

Boundary and application conditions:

- The mechanical alignment of the movement axis and thus the mounting points of hydraulic cylinder and piston rod must be ensured. Lateral forces on the guides of piston rod and piston are to be avoided. It may be necessary to consider the own weight of the hydraulic cylinder (MP1, MP3, MP5, MT1, MT2 or MT4) or the piston rod.
- The kinking length/kinking load of the piston rod and/or the hydraulic cylinder must be observed (see page topic Kinking).
- The maximum admissible stroke velocities with regard to the suitability/load of seals must be observed as must their compatibility with the properties of the hydraulic fluid (see page topic Seals).
- The maximum admissible velocities/kinetic energies when moving into the end positions, also considering external loads, must be observed.
Danger: Excess pressure
- The maximum admissible operating pressure must be complied with in any operating state of the hydraulic cylinder. Possible pressure intensification resulting from the area ratio of annulus area to piston area and possible throttling points is to be observed.
- Detrimental environmental influences, like e. g. aggressive finest particles, vapors, high temperatures, etc. as well as contamination and deterioration of the hydraulic fluid are to be avoided.

Notice: This list does not claim to be complete. In case of questions regarding the compatibility with the medium or exceedance of the boundary or application conditions, please contact us.

Acceptance:

Each cylinder is tested according to Bosch Rexroth standard and in compliance with ISO 10100: 2001.

Safety instructions:

For the assembly, commissioning and maintenance of hydraulic cylinders, the operating instructions data sheet 07100-B have to be observed!

Service and repair works have to be performed by Bosch Rexroth or by personnel especially trained for this purpose. No warranty is accepted for damage as a consequence of assembly, maintenance or repair works not performed by Bosch Rexroth.

Check lists for hydraulic cylinders:

Cylinders the characteristics and/or application parameters of which deviate from the values specified in the data sheet can only be offered as a special version upon request. For offers, the variations of the characteristics and/or application parameters must be described in the check lists for hydraulic cylinders (data sheet 07200).

Double-acting cylinders with continuous piston rod:

With this design type, the friction is considerably higher than with the "CD version" with simple piston rod.

Stroke tolerances:

According to ISO 6020-2, a stroke tolerance of 0/+2 mm is admissible for strokes up to 1250 mm; for larger strokes please contact us.

A tolerance of ± 0.3 mm is possible as option, smaller tolerances are not reasonable for tie rod cylinders.

Minimum strokes:

For the "MT4" mounting, the minimum stroke is to be observed due to the trunnion width, see pages 16 and 36.

When using end position cushioning, the minimum stroke must also be observed, see page 56 "End position cushioning".

Support width extension and tie rod support are possible upon request.

Line connections:

The cylinders of series CDT3/CGT3 are supplied with pipe thread or enlarged pipe thread according to ISO 1179-1 or metric ISO thread according to ISO 6149-1.

The cylinders of series CST3 are supplied with pipe thread according to ISO 1179-1 or with subplate.

Stroke velocity:

See information on stroke length and stroke velocity, higher stroke velocity on request.

If the extension velocity is considerably higher than the retraction velocity of the piston rod, drag-out losses of the medium may result. If necessary, please consult us.

Information on stroke length and stroke velocity

ØAL (mm)		25	32	40	50	63	80	100	125	160	200
Min recommended stroke in mm	without damping	–	–	–	–	–	–	–	–	–	–
	with damping	30	32	46	44	50	54	56	66	72	80
Maximum velocity (m/s)	Seal design M; 160 bar	0.50			0.40		0.30		0.25		
	Seal design M; 100 bar	0.70			0.60		0.40		0.35		
	Seal design T, S; 160 bar	1.00			0.80		0.60		0.50		
Recommended minimum velocity (mm/s)	Seal design M	30									
	Seal design T, S	1									

Project planning software ICS (Interactive Catalog System)

The ICS (Interactive Catalog System) is a selection and project planning aid for hydraulic cylinders. The ICS allows designers for machines and systems to quickly and reliably find the perfect hydraulic cylinder solution through logic-guided type key enquiries. This software helps to solve design and project planning tasks more quickly and efficiently.

After having been guided through the product selection, the user quickly and reliably gets the exact technical data of the selected component as well as 2D and 3D CAD data in the correct file format for all common CAD systems. This allows users to reduce costs while increasing their competitiveness.

Online: www.boschrexroth.com/ics

Areas, forces, flow: Series CDT3 (for operating pressure up to 210 bar)

Piston \varnothing AL mm	Piston rod \varnothing MM mm		Area ratio φ A_1/A_3	Areas			Force ¹⁾						Flow at 0.1 m/s ²⁾			max. available stroke length ⁵⁾ (mm)
	160 bar	210 bar		Piston A_1 cm ²	Rod A_2 cm ²	Ring A_3 cm ²	Pressure F_1 kN		Diff. F_2 kN		Pulling F_3 kN		Off q_{V1} l/min	Diff. q_{V2} l/min	On q_{V3} l/min	
							160 bar	210 bar	160 bar	210 bar	160 bar	210 bar				
25	12	-	1.3	4.91	1.13	3.78	7.86	-	1.81	-	6.05	-	2.9	0.70	2.30	600
	18	18	2.07		2.54	2.37		10.31	4.06	5.33	3.79	4.98		1.50	1.40	
32	14	-	1.25	8.04	1.54	6.5	12.86	-	2.46	-	10.40	-	4.8	0.90	3.90	800
	22	22	1.90		3.80	4.24		16.88	6.08	7.98	6.78	8.90		2.30	2.50	
40	18	-	1.25	12.56	2.54	10.02	20.10	-	4.06	-	16.03	-	7.5	1.50	6.00	1000
	22 ³⁾	22 ³⁾	1.43		3.80	8.76		26.38	6.08	7.98	14.02	18.40		2.30	5.30	
	28	28	1.96		6.16	6.4		9.86	12.94	10.24	13.44	3.70		3.80		
50	22	-	1.25	19.63	3.8	15.83	31.41	-	6.08	-	25.33	-	11.8	2.30	9.50	1200
	28 ³⁾	28 ³⁾	1.46		6.16	13.47		41.22	9.86	12.94	21.55	28.29		3.70	8.10	
	36	36	2.08		10.18	9.45		16.29	21.38	15.12	19.85	6.10		5.70		
63	28	-	1.25	31.17	6.16	25.01	49.87	-	9.86	12.94	40.02	-	18.7	3.70	15.00	1400
	36 ³⁾	36 ³⁾	1.48		10.18	20.99		65.46	16.29	21.38	33.58	44.08		6.10	12.60	
	45	45	2.04		15.90	15.27		25.44	33.39	24.43	32.07	9.50		9.20		
80	36	-	1.25	50.26	10.18	40.08	80.42	-	16.29	21.38	64.13	-	30.2	6.10	24.00	1700
	45 ³⁾	45 ³⁾	1.46		15.90	34.36		105.55	25.44	33.39	54.98	72.16		9.50	20.60	
	56	56	1.96		24.63	25.63		39.41	51.72	41.01	53.82	14.80		15.40		
100	45	-	1.25	78.54	15.90	62.64	125.66	-	25.44	33.39	100.22	-	47.1	9.50	37.60	2000
	56 ³⁾	56 ³⁾	1.46		24.63	53.91		164.93	39.41	51.72	86.26	113.21		14.80	32.30	
	70	70	1.96		38.48	40.06		61.57	80.81	64.10	84.13	23.10		24.00		
125	56	-	1.25	122.72	24.63	98.09	196.35	-	39.41	51.72	156.94	-	73.6	14.80	58.90	2300
	70 ³⁾	70 ³⁾	1.46		38.48	84.24		4)	61.57	80.81	134.78	4)		23.10	50.50	
	90	90	2.08		63.62	59.1		101.79	133.60	94.56	4)	38.20		35.50		
160	70	-	1.25	201.06	38.48	162.58	321.70	-	61.57	80.81	260.13	-	120.6	23.10	97.50	2600
	110	110 ⁴⁾	1.90		95.03	106.03		4)	152.05	199.56	169.65	4)		57.00	63.60	
200	90	-	1.25	314.16	63.62	250.54	502.66	-	101.79	133.60	400.86	-	188.5	38.20	150.30	3000
	140	140 ⁴⁾	1.96		153.94	160.22		4)	246.30	323.27	256.35	4)		92.40	96.10	

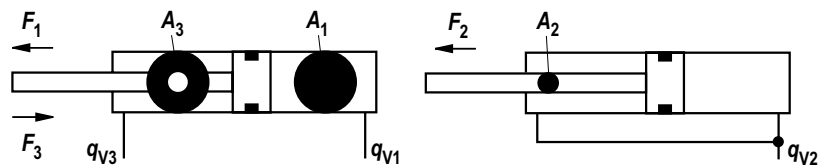

¹⁾ Theoretical static cylinder force (without consideration of the efficiency and admissible load for attachment parts like e.g. swivel heads, plates or valves, etc.)

²⁾ Stroke velocity

³⁾ Piston rod \varnothing not standardized

⁴⁾ With operating pressures up to 210 bar only on request

⁵⁾ Larger stroke lengths upon request

Overview types of mounting: Series CDT3 (for operating pressure up to 210 bar)

CDT3 ME5 (ISO/DIN/NF)

see page 10, 11



CDT3 ME6 (ISO/DIN/NF)

see page 10, 11



CDT3 MP5 (ISO/DIN/NF)

see page 12, 13



CDT3 MS2 (ISO/DIN/NF)

see page 14, 15



CDT3 MT4 (ISO/DIN/NF)

see page 16, 17

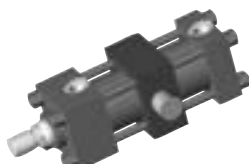

CDT3 MT1 (ISO/DIN/NF)

see page 18, 19



CDT3 MT2 (ISO/DIN/NF)

see page 18, 19

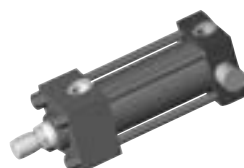

CDT3 MX1 (ISO/DIN/NF)

see page 20, 21

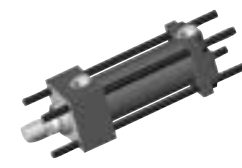

CDT3 MX2 (ISO/DIN/NF)

see page 22, 23

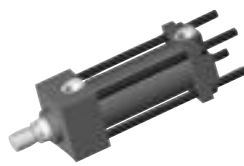

CDT3 MX3 (ISO/DIN/NF)

see page 22, 23



CDT3 MX5 (NF)

see page 24, 25

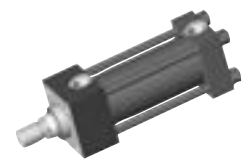

CDT3 MP1 (ISO/DIN/NF)

see page 26, 27

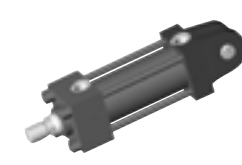

CDT3 MP3 (ISO/DIN/NF)

see page 26, 27



Ordering code: Series CDT3 (for operating pressure up to 210 bar)

The preferred cylinder designs are marked in gray.

CD	T3	/	/	/	Z	3X											*
-----------	-----------	---	---	---	----------	-----------	--	--	--	--	--	--	--	--	--	--	---

Differential cylinder = **CD**

Series = **T3**

Types of mounting DIN/ISO

Rectangular flange at head = **ME5**

Rectangular flange at base = **ME6**

Self-aligning clevis at base = **MP5**

Foot mounting = **MS2**

Trunnion in center ¹⁾ = **MT4**

Types of mounting ISO

Fork at base = **MP1**

Swivel eye at base = **MP3**

Trunnion at head = **MT1**

Trunnion at base = **MT2**

Extended tie rod, on both sides = **MX1**

Extended tie rod, at base = **MX2**

Extended tie rod, at head = **MX3**

Tapped hole at head ²⁾ = **MX5**

Piston Ø (ØAL) 25 to 200 mm

Piston rod Ø (ØMM) 12 to 140 mm ¹³⁾

Stroke length in mm ¹¹⁾

Design principle

Head and base connected to tie rod = **Z**

Component series = **3X**

30 to 39 unchanged installation and connection dimensions

Line connection/design

Pipe thread (ISO 1179-1) = **B**

Metric ISO thread (ISO 6149-1)¹⁷⁾ = **R**

Enlarged pipe thread (ISO 1179-1) = **S**

Line connection/position at head

see page 41

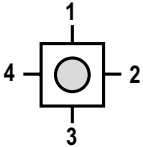

View to piston rod

1 = 1
2 = 2
3 = 3
4 = 4

Comments:

- Trunnion position freely selectable; when ordering, always specify the "XV" dimension in the plain text in mm.
- Not ISO standardized
- With type of mounting MS2 and piston Ø 25 and end position cushioning, "E" is not possible
- With piston Ø 25 to 100 mm: only line connection "B" possible.
With piston Ø 125 to 200 mm: only DIN types of mounting and line connection "B" possible.
- Not possible with type of mounting MX1 and MX3.
- See page 44 (Only possible with standardized piston rod Ø 22 to 140 mm), observe the max. operating pressure.
- Observe the max. stroke length available, page 5, and the admissible stroke length (according to kinking calculation) on pages 52 to 55
- See page 44 (Only possible with standardized piston rod Ø 18 to 140 mm), observe the max. operating pressure.
- Observe the admissible piston rod Ø and assigned threads at the piston rod end for 210 bar (pages 5 and 10 to 27)

Further details in the plain text

Option 2

W = Without option

Y = Specify the piston rod extension LY in the plain text in mm

Option 1

W = Without option

B = ^{3; 4; 16)} Leakage oil connection

A = Threaded coupling, on both sides

Seal design

M = Standard seal system

T = Reduced friction

S = High temperature with reduced friction

End position cushioning

see pages 56 to 60

U = Without

D = On both sides, self-adjusting

S = Head side, self-adjusting

K = Base side, self-adjusting

E = ⁴⁾ On both sides, adjustable

Piston rod end

see pages 10 to 27

H = ¹⁴⁾ Thread (DIN/ISO) for swivel head CGKA

D = ¹⁵⁾ Thread (ISO) for swivel head CGKA

E = ¹²⁾ Internal thread

F = ^{5; 14)} With mounted swivel head CGKA (DIN/ISO)

K = ^{5; 15)} With mounted swivel head CGKA (ISO)

T = ⁶⁾ With trunnion

Piston rod design

H = Hardened and hard chromium-plated

Line connection/position at base

see page 41

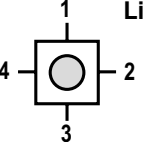

View to piston rod

1 = 1
2 = 2
3 = 3
4 = 4

Order example:

CDT3MP5/50/36/300Z2X/B11HHDMWW

When selecting, please observe the limitations on the corresponding catalog pages!

¹⁴⁾ For operating pressure up to 160 bar

¹⁵⁾ For operating pressure up to 210 bar

¹⁶⁾ Not possible with MT1.

¹⁷⁾ For type of mounting ME5 and ME6, only position 1 and 3 possible

Areas, forces, flow: Series CGT3 (for operating pressure up to 160 bar)

Piston $\varnothing AL$ mm	Piston rod $\varnothing MM$ mm	Areas A_3 cm ²	Force at 160 bar ¹⁾ F_3 kN	Flow at 0.1 m/s ²⁾ q_{V3} l/min	max. available stroke length (mm) ⁴⁾
25	12	3.78	6.04	2.3	600
	18	2.37	3.78	1.4	
32	14	6.50	10.40	3.9	800
	22	4.24	6.79	2.5	
40	18	10.02	16.03	6.0	1000
	22 ³⁾	8.77	14.02	5.3	
	28	6.40	10.25	3.8	
50	22	15.83	25.33	9.5	1200
	28 ³⁾	13.48	21.56	8.1	
	36	9.45	15.13	5.7	
63	28	25.01	40.02	15.0	1400
	36 ³⁾	20.99	33.59	12.6	
	45	15.27	24.43	9.2	
80	36	40.08	64.14	24.0	1700
	45 ³⁾	34.36	54.98	20.6	
	56	25.63	41.02	15.4	
100	45	62.64	100.21	37.6	2000
	56 ³⁾	53.91	86.26	32.3	
	70	40.06	64.09	24.0	
125	56	98.09	156.94	58.9	2300
	70 ³⁾	84.23	134.77	50.5	
	90	59.10	94.56	35.5	
160	70	162.58	260.12	97.5	2600
	110	106.03	169.64	63.6	
200	90	250.54	400.86	150.3	3000
	140	160.22	256.35	96.1	

1) Theoretical static cylinder force (without consideration of the efficiency and admissible load for attachment parts like e.g. swivel heads, plates or valves, etc.)

2) Stroke velocity

3) Piston rod \varnothing not standardized

4) Larger stroke lengths upon request

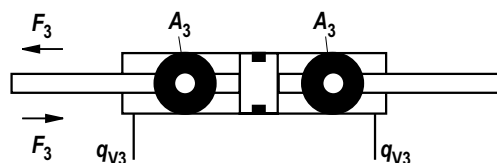

Overview types of mounting: Series CGT3 (for operating pressure up to 160 bar)

CGT3 ME5

see page 10, 11

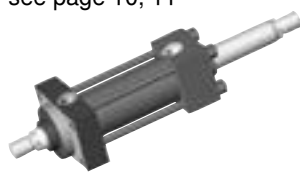

CGT3 MS2

see page 14, 15



CGT3 MT4

see page 16, 17



CGT3 MT1

see page 18, 19



CGT3 MX1

see page 20, 21

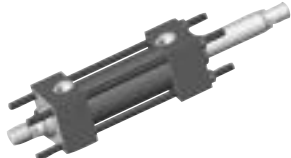

CGT3 MX3

see page 22, 23

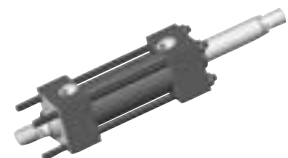

CGT3 MX5

see page 24, 25



Ordering code: Series CGT3 (for operating pressure up to 160 bar)

	CG	T3	/	/	/	Z	3X													*
--	-----------	-----------	---	---	---	----------	-----------	--	--	--	--	--	--	--	--	--	--	--	--	---

Double-acting cylinder ¹⁰⁾ = **CG**

Series = **T3**

Types of mounting

- Rectangular flange at head = **ME5**
- Foot mounting = **MS2**
- Trunnion in center ¹⁾ = **MT4**
- Trunnion at head = **MT1**
- Extended tie rods, on both sides = **MX1**
- Extended tie rods, at head = **MX3**
- Tapped hole at head = **MX5**

Piston Ø (ØAL) 25 to 200 mm

Piston rod Ø (ØMM) 12 to 140 mm

Stroke length in mm ¹⁴⁾

Design principle

Head and base connected to tie rod = **Z**

Component series = **3X**
30 to 39 unchanged installation and connection dimensions

Line connection/design

- Pipe thread (ISO 1179-1) = **B**
- Metric ISO thread (ISO 6149-1)¹⁷⁾ = **R**
- Enlarged pipe thread (ISO 1179-1) = **S**

Line connection/position at head
see page 41

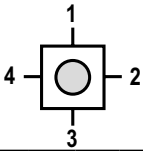

= 1

= 2

= 3

= 4

View to piston rod

Further details in the plain text

Option 2

W = Without option

Y = Specify the piston rod extension LY in the plain text in mm

Option 1

W = Without option

B = ^{3; 4; 16)} Leakage oil connection

A = Threaded coupling, on both sides

Seal design

M = Standard seal system

T = Servo quality/Reduced friction

S = High temperature with reduced friction

End position cushioning
see pages 56 to 60

U = Without

D = On both sides, self-adjusting

E = ⁴⁾ On both sides, adjustable

Piston rod end
see pages 10 to 27

H = Thread (DIN/ISO) for swivel head CGKA

D = Thread (ISO) for swivel head CGKA

E = ¹²⁾ Internal thread

F = ⁵⁾ With mounted swivel head CGKA (DIN/ISO)

K = ⁵⁾ With mounted swivel head CGKA (ISO)

Piston rod design

H = Hardened and hard chromium-plated

Line connection/position at base
see page 41

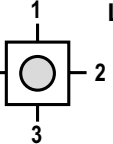

1 =

2 = 4

3 =

4 =

View to piston rod

Comments:

- ¹⁾ Trunnion position freely selectable; when ordering, always specify the "XV" dimension in the plain text in mm.
- ³⁾ With type of mounting MS2 and piston Ø 25 and end position cushioning, "E" is not possible
- ⁴⁾ With piston Ø 25 to 100 mm: only line connection "B" possible.
With piston Ø 125 to 200 mm: only DIN types of mounting and line connection "B" possible.
- ⁵⁾ Not possible with type of mounting MX1 and MX3.
- ¹⁰⁾ Not standardized
- ¹²⁾ see page 44 (Only possible with standardized piston rod Ø 18 to 140 mm), observe the max. operating pressure
- ¹⁴⁾ Observe the max. stroke length available, page 8, and the admissible stroke length (according to kinking calculation) on pages 52 to 55
- ¹⁶⁾ Not possible with MT1.
- ¹⁷⁾ For type of mounting ME5 and ME6, only position 1 and 3 possible

Order example:
CGT3ME5/80/56/400Z2X/B11HDMWW
When selecting, please observe the limitations on the corresponding catalog pages!

Dimensions: Rectangular flange at head CDT3/CGT3; ME5 (dimensions in mm)
Rectangular flange at base CDT3; ME6 (dimensions in mm)

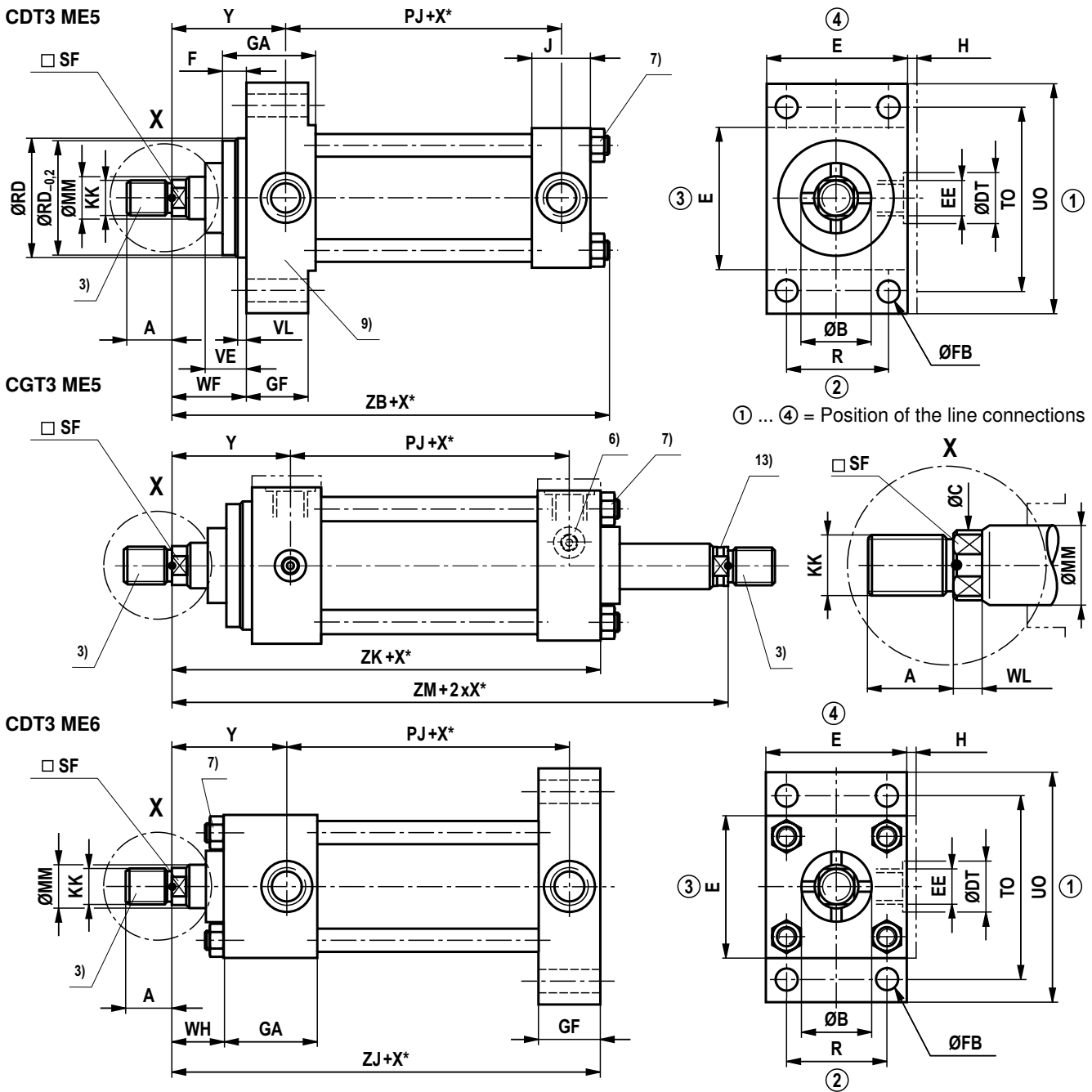

ØAL	F max	ØFB H13	GF ⁹⁾	R JS13	TO JS13	UO max	VE max	VL min	ZB max	ZJ ± 1	ZK ± 1	ZM ± 2
25	10	5.5	25	27	51	65	16	3	121	114	138	154
32	10	6.6	26.5	33	58	70	22	3	137	128	151	177
40	10	11	38	41	87	110	22	3	166	153	172	196
50	16	14	38	52	105	130	25	4	176	159	183	207
63	16	14	38	65	117	145	29	4	185	168	190	223
80	20	18	45	83	149	180	29	4	212	190	216	246
100	22	18	45	97	162	200	32	5	225	203	230	265
125	22	22	58	126	208	250	32	5	260	232	254	289
160	25	26	58	155	253	300	32	5	279	245	270	302
200	25	33	76	190	300	360	32	5	336	299	329	361

Dimensions: CDT3/CGT3; ME5 (dimensions in mm)
CDT3; ME6 (dimensions in mm)

ØAL	ØMM	DIN / ISO ¹⁾ (for operating pressure up to 160 bar)					ISO ²⁾ (for operating pressure up to 210 bar)					ØB f9	ØRD f8
		KK ¹⁾	A ¹⁾ max	ØC	SF	WL	KK ²⁾	A ²⁾ max	ØC	SF	WL		
25	12	M10x1.25	14	11	10	5	–	–	–	–	–	24	38
	18	M10x1.25	14	16.5	14	5	M14x1.5	18	16.5	14	5	30	38
32	14	M12x1.25	16	13	12	5	–	–	–	–	–	26	42
	22	M12x1.25	16	20.5	18	5	M16x1.5	22	20.5	18	5	34	42
40	18	M14x1.5	18	16.5	14	5	–	–	–	–	–	30	62
	22 ¹²⁾	M14x1.5	18	20.5	18	5	M16x1.5	22	20.5	18	5	34	62
	28	M14x1.5	18	26	22	7	M20x1.5	28	26	22	7	42	62
50	22	M16x1.5	22	20.5	18	5	–	–	–	–	–	34	74
	28 ¹²⁾	M16x1.5	22	26	22	7	M20x1.5	28	26	22	7	42	74
	36	M16x1.5	22	34	30	8	M27x2	36	34	30	8	50	74
63	28	M20x1.5	28	26	22	7	–	–	–	–	–	42	75
	36 ¹²⁾	M20x1.5	28	34	30	8	M27x2	36	34	30	8	50	88
	45	M20x1.5	28	43	36	10	M33x2	45	43	36	10	60	88
80	36	M27x2	36	34	30	8	–	–	–	–	–	50	82
	45 ¹²⁾	M27x2	36	43	36	10	M33x2	45	43	36	10	60	105
	56	M27x2	36	54	46	10	M42x2	56	54	46	10	72	105
100	45	M33x2	45	43	36	10	–	–	–	–	–	60	92
	56 ¹²⁾	M33x2	45	54	46	10	M42x2	56	54	46	10	72	125
	70	M33x2	45	68	60	15	M48x2	63	68	60	15	88	125
125	56	M42x2	56	54	46	10	–	–	–	–	–	72	105
	70 ¹²⁾	–	–	–	–	–	M48x2 ¹⁴⁾	63	68	60	15	88	150
	90	M42x2	56	86	75	15	M64x3 ¹⁴⁾	85	86	75	15	108	150
160	70	M48x2	63	68	60	15	–	–	–	–	–	88	125
	110	M48x2	63	106	92	18	M80x3 ¹⁴⁾	95	106	92	18	133	170
200	90	M64x3	85	86	75	15	–	–	–	–	–	108	150
	140	M64x3	85	136	125	18	M100x3 ¹⁴⁾	112	136	125	18	163	210

ØAL	E	EE	ØDT	EE	ØDT	GA	H ⁵⁾	J	PJ ¹⁰⁾ ± 1.25	PJ ¹¹⁾ ± 1.25	WF ± 2	WH ± 2	Y ¹⁰⁾ ± 2	Y ¹¹⁾ ± 2
25	40 ± 1.5	G 1/4	25	M14x1.5	21	46.5	5	22.5	53	64.5	25	15	50	38.5
32	45 ± 1.5	G 1/4	25	M14x1.5	21	48	5	25	56	68.5	35	25	60	47.5
40	63 ± 1.5	G 3/8	28	M18x1.5	26	52.5	–	33.5	73	77	35	25	62	58
50	75 ± 1.5	G 1/2	34	M22x1.5	29	57.5	–	33.5	74	78	41	25	67	63
63	90 ± 1.5	G 1/2	34	M22x1.5	29	57.5	–	35.5	80	81	48	32	71	70
80	115 ± 1.5	G 3/4	42	M27x2	34	67	–	41	93	93	51	31	77	77
100	130 ± 2	G 3/4	42	M27x2	34	70	–	43	101	101	57	35	82	82
125	165 ± 2	G 1	47	M33x2	43	76	–	54	117	117	57	35	86	86
160	205 ± 2	G 1	47	M33x2	43	83	–	58	130	130	57	32	86	86
200	245 ± 2	G 1 1/4	58	M42x2	52	107.5	–	77.5	165	165	57	32	98	98

ØAL = Piston Ø

ØMM = Piston rod Ø

X* = Stroke length

1) Thread for piston rod ends "F" and "H"

2) Thread for piston rod ends "D" and "K"

3) For piston rod ends "E" and "T" see page 44

5) "H" dimension always in line connection position; exception ME5 head and ME6 base

6) For the position of the line connections and the bleeding see page 41

7) Tightening torque see page 63

9) Flange thickness according to DIN 24554

10) ME5: for line connection position "1" and "3" at head

11) ME5: for line connection position "2" and "4" at head

12) Piston rod Ø not standardized

13) CG design: Piston rod marked with groove, only admissible for 50 bar tensile load

14) With operating pressures up to 210 bar only on request

Line connection/ position	Position H	
	ME5 head	ME6 base
1	1	1
2	1	1
3	3	3
4	3	3

Dimensions: Self-aligning clevis at base CTD3; MP5 (dimensions in mm)

CDT3 MP5

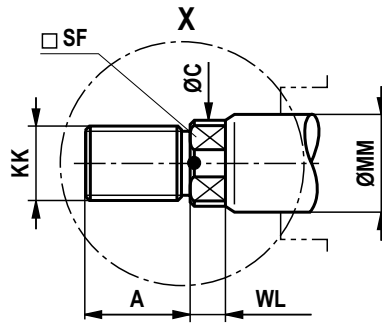
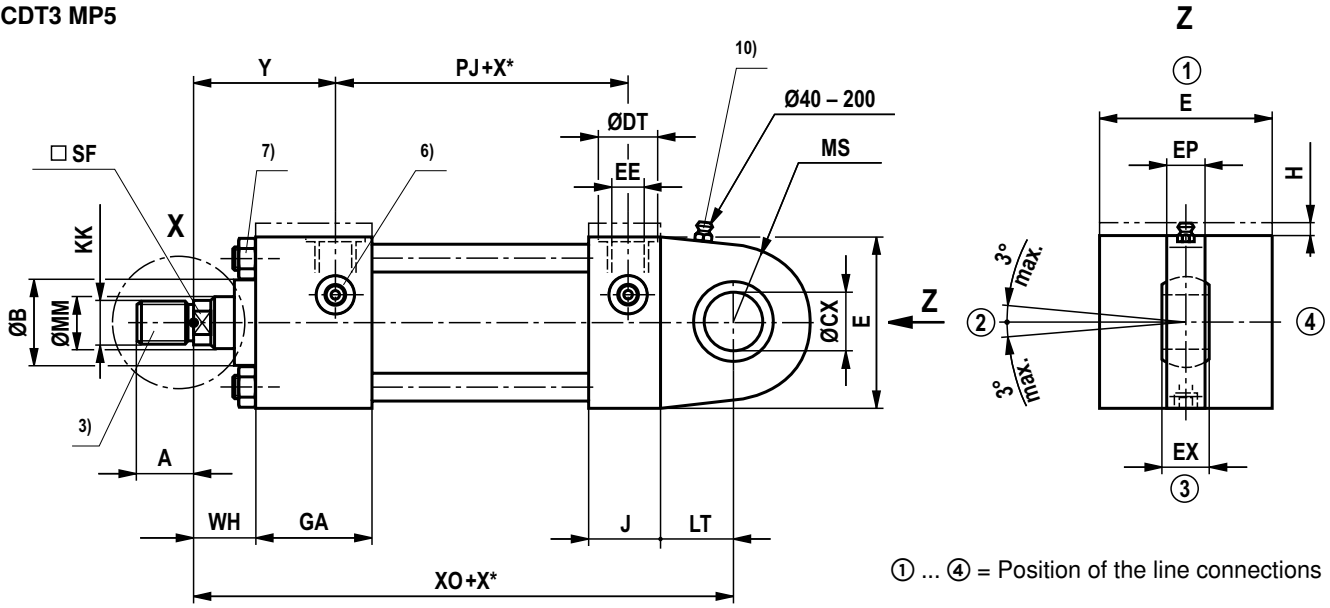

ØAL	ØCX	EP h13	EX	LT min	XO ± 1.5	MS max
25	12 - 0.008	8	10 - 0.12	16	130	20
32	16 - 0.008	11	14 - 0.12	20	148	22.5
40	20 - 0.012	13	16 - 0.12	25	178	29
50	25 - 0.012	17	20 - 0.12	31	190	33
63	30 - 0.012	19	22 - 0.12	38	206	40
80	40 - 0.012	23	28 - 0.12	48	238	50
100	50 - 0.012	30	35 - 0.12	58	261	62
125	60 - 0.015	38	44 - 0.15	72	304	80
160	80 - 0.015	47	55 - 0.15	92	337	100
200	100 - 0.020	57	70 - 0.20	116	415	120

Dimensions: Self-aligning clevis at base CTD3; MP5 (dimensions in mm)

ØAL	ØMM	DIN / ISO ¹⁾ (for operating pressure up to 160 bar)					ISO ²⁾ (for operating pressure up to 210 bar)					ØB f9
		KK ¹⁾	A ¹⁾ max	ØC	SF	WL	KK ²⁾	A ²⁾ max	ØC	SF	WL	
25	12	M10x1.25	14	11	10	5	–	–	–	–	–	24
	18	M10x1.25	14	16.5	14	5	M14x1.5	18	16.5	14	5	30
32	14	M12x1.25	16	13	12	5	–	–	–	–	–	26
	22	M12x1.25	16	20.5	18	5	M16x1.5	22	20.5	18	5	34
40	18	M14x1.5	18	16.5	14	5	–	–	–	–	–	30
	22 ¹²⁾	M14x1.5	18	20.5	18	5	M16x1.5	22	20.5	18	5	34
	28	M14x1.5	18	26	22	7	M20x1.5	28	26	22	7	42
50	22	M16x1.5	22	20.5	18	5	–	–	–	–	–	34
	28 ¹²⁾	M16x1.5	22	26	22	7	M20x1.5	28	26	22	7	42
	36	M16x1.5	22	34	30	8	M27x2	36	34	30	8	50
63	28	M20x1.5	28	26	22	7	–	–	–	–	–	42
	36 ¹²⁾	M20x1.5	28	34	30	8	M27x2	36	34	30	8	50
	45	M20x1.5	28	43	36	10	M33x2	45	43	36	10	60
80	36	M27x2	36	34	30	8	–	–	–	–	–	50
	45 ¹²⁾	M27x2	36	43	36	10	M33x2	45	43	36	10	60
	56	M27x2	36	54	46	10	M42x2	56	54	46	10	72
100	45	M33x2	45	43	36	10	–	–	–	–	–	60
	56 ¹²⁾	M33x2	45	54	46	10	M42x2	56	54	46	10	72
	70	M33x2	45	68	60	15	M48x2	63	68	60	15	88
125	56	M42x2	56	54	46	10	–	–	–	–	–	72
	70 ¹²⁾	–	–	–	–	–	M48x2 ¹⁴⁾	63	68	60	15	88
	90	M42x2	56	86	75	15	M64x3 ¹⁴⁾	85	86	75	15	108
160	70	M48x2	63	68	60	15	–	–	–	–	–	88
	110	M48x2	63	106	92	18	M80x3 ¹⁴⁾	95	106	92	18	133
200	90	M64x3	85	86	75	15	–	–	–	–	–	108
	140	M64x3	85	136	125	18	M100x3 ¹⁴⁾	112	136	125	18	163

ØAL	E	EE	ØDT	EE	ØDT	GA	H ⁵⁾	J	PJ ± 1.25	WH ± 2	Y ± 2
25	40 ± 1.5	G 1/4	25	M14x1.5	21	46.5	5	22.5	53	15	50
32	45 ± 1.5	G 1/4	25	M14x1.5	21	48	5	25	56	25	60
40	63 ± 1.5	G 3/8	28	M18x1.5	26	52.5	–	33.5	73	25	62
50	75 ± 1.5	G 1/2	34	M22x1.5	29	57.5	–	33.5	74	25	67
63	90 ± 1.5	G 1/2	34	M22x1.5	29	57.5	–	35.5	80	32	71
80	115 ± 1.5	G 3/4	42	M27x2	34	67	–	41	93	31	77
100	130 ± 2	G 3/4	42	M27x2	34	70	–	43	101	35	82
125	165 ± 2	G 1	47	M33x2	43	76	–	54	117	35	86
160	205 ± 2	G 1	47	M33x2	43	83	–	58	130	32	86
200	245 ± 2	G 1 1/4	58	M42x2	52	107.5	–	77.5	165	32	98

ØAL = Piston Ø

ØMM = Piston rod Ø

X* = Stroke length

1) Thread for piston rod ends "F" and "H"

2) Thread for piston rod ends "D" and "K"

3) For piston rod ends "E" and "T" see page 44

5) "H" dimension always in line connection position

6) For the position of the line connections and the bleeding see page 41

7) Tightening torque see page 63

10) Lubricating nipple M6 DIN 71412 from piston Ø 40 mm

12) Piston rod Ø not standardized

14) With operating pressures up to 210 bar only on request

Dimensions: Foot mounting CDT3/CGT3; MS2 (dimensions in mm)

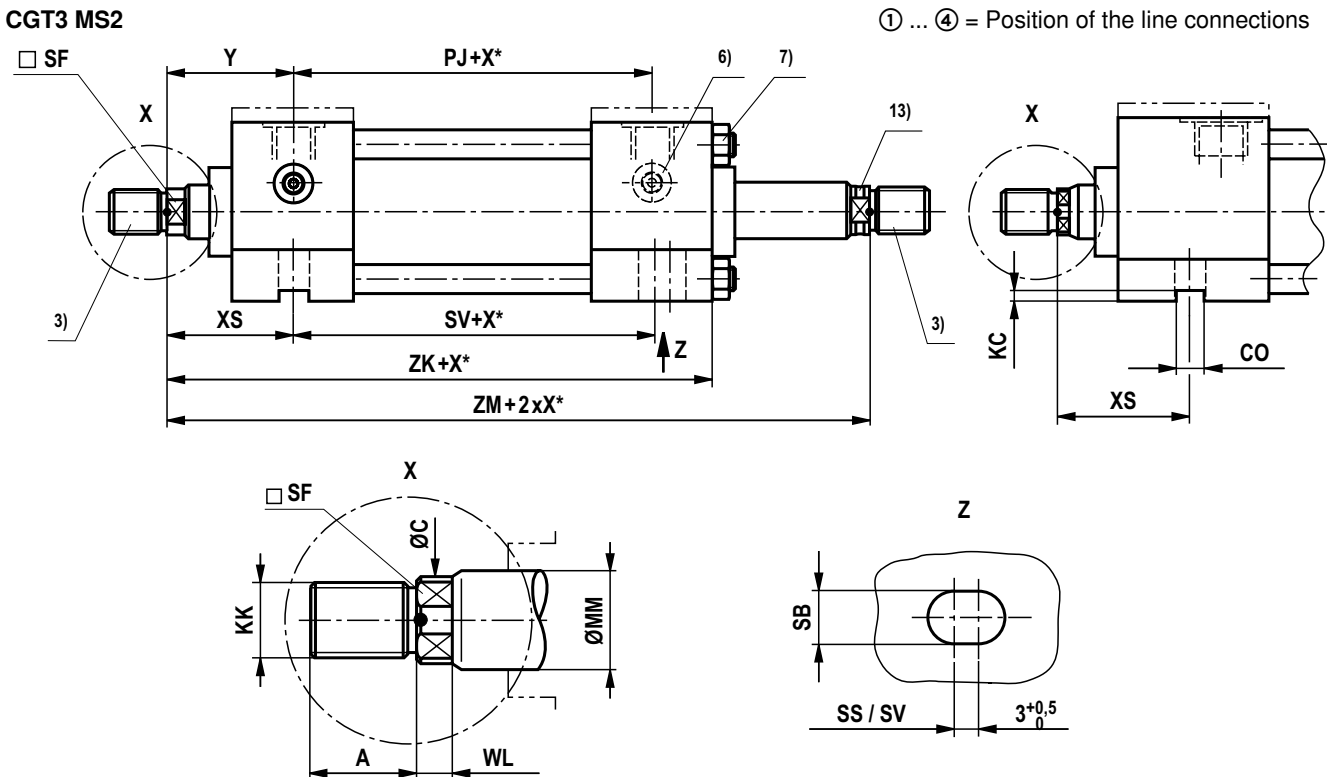
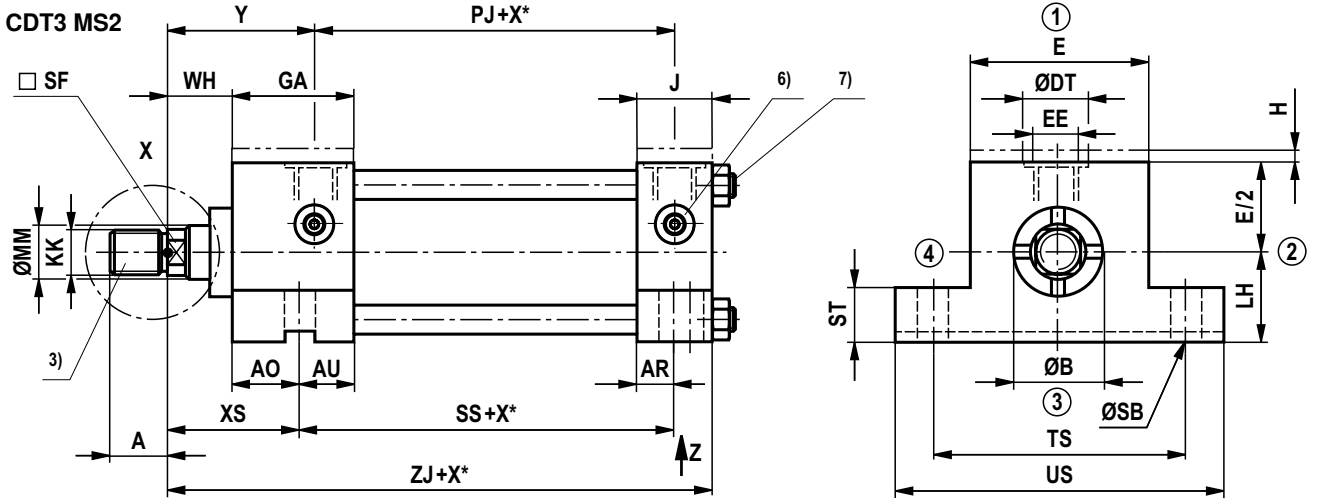

ØAL	CO N9	KC +0.2 0	LH h10	ØSB H13	SS ± 1.25	ST	SV ± 1	TS JS13	US max	XS ± 2	ZJ ± 1	ZK ± 1	ZM ± 2	AO	AU
25	12	3	19	6.6	72	8.5	87	54	72	33	114	138	154	18	28.5
32	12	4	22	9	72	12.5	87	63	84	45	128	151	177	20	28
40	12	4	31	11	97	12.5	105	83	103	45	153	172	196	20	32.5
50	12	4.5	37	14	91	19	99	102	127	54	159	183	207	29	28
63	16	4.5	44	18	85	26	92	124	161	65	168	190	223	33	24.5
80	16	5	57	18	104	26	110	149	186	68	190	216	246	39	28
100	16	6	63	26	101	32	107	172	216	79	203	230	265	44	26
125	20	5	82	26	130	32	131	210	254	79	232	254	289	44	32
160	30	8	101	33	129	38	130	260	318	86	245	270	302	54	29
200	40	8	122	39	171	44	177	311	381	92	299	329	361	60	47.5

Dimensions: Foot mounting CDT3/CGT3; MS2 (dimensions in mm)

ØAL	ØMM	DIN / ISO ¹⁾ (for operating pressure up to 160 bar)					ISO ²⁾ (for operating pressure up to 210 bar)					ØB f9
		KK ¹⁾	A ¹⁾ max	ØC	SF	WL	KK ²⁾	A ²⁾ max	ØC	SF	WL	
25	12	M10x1.25	14	11	10	5	–	–	–	–	–	24
	18	M10x1.25	14	16.5	14	5	M14x1.5	18	16.5	14	5	30
32	14	M12x1.25	16	13	12	5	–	–	–	–	–	26
	22	M12x1.25	16	20.5	18	5	M16x1.5	22	20.5	18	5	34
40	18	M14x1.5	18	16.5	14	5	–	–	–	–	–	30
	22 ¹²⁾	M14x1.5	18	20.5	18	5	M16x1.5	22	20.5	18	5	34
	28	M14x1.5	18	26	22	7	M20x1.5	28	26	22	7	42
50	22	M16x1.5	22	20.5	18	5	–	–	–	–	–	34
	28 ¹²⁾	M16x1.5	22	26	22	7	M20x1.5	28	26	22	7	42
	36	M16x1.5	22	34	30	8	M27x2	36	34	30	8	50
63	28	M20x1.5	28	26	22	7	–	–	–	–	–	42
	36 ¹²⁾	M20x1.5	28	34	30	8	M27x2	36	34	30	8	50
	45	M20x1.5	28	43	36	10	M33x2	45	43	36	10	60
80	36	M27x2	36	34	30	8	–	–	–	–	–	50
	45 ¹²⁾	M27x2	36	43	36	10	M33x2	45	43	36	10	60
	56	M27x2	36	54	46	10	M42x2	56	54	46	10	72
100	45	M33x2	45	43	36	10	–	–	–	–	–	60
	56 ¹²⁾	M33x2	45	54	46	10	M42x2	56	54	46	10	72
	70	M33x2	45	68	60	15	M48x2	63	68	60	15	88
125	56	M42x2	56	54	46	10	–	–	–	–	–	72
	70 ¹²⁾	–	–	–	–	–	M48x2 ¹⁴⁾	63	68	60	15	88
	90	M42x2	56	86	75	15	M64x3 ¹⁴⁾	85	86	75	15	108
160	70	M48x2	63	68	60	15	–	–	–	–	–	88
	110	M48x2	63	106	92	18	M80x3 ¹⁴⁾	95	106	92	18	133
200	90	M64x3	85	86	75	15	–	–	–	–	–	108
	140	M64x3	85	136	125	18	M100x3 ¹⁴⁾	112	136	125	18	163

ØAL	E	EE	ØDT	EE	ØDT	GA	H ⁵⁾	J	PJ ± 1.25	WH ± 2	Y ± 2	AR
25	40 ± 1.5	G 1/4	25	M14x1.5	21	46.5	5	22.5	53	15	50	13.5
32	45 ± 1.5	G 1/4	25	M14x1.5	21	48	5	25	56	25	60	14
40	63 ± 1.5	G 3/8	28	M18x1.5	26	52.5	–	33.5	73	25	62	22.5
50	75 ± 1.5	G 1/2	34	M22x1.5	29	57.5	–	33.5	74	25	67	19.5
63	90 ± 1.5	G 1/2	34	M22x1.5	29	57.5	–	35.5	80	32	71	17.5
80	115 ± 1.5	G 3/4	42	M27x2	34	67	–	41	93	31	77	23
100	130 ± 2	G 3/4	42	M27x2	34	70	–	43	101	35	82	20
125	165 ± 2	G 1	47	M33x2	43	76	–	54	117	35	86	31
160	205 ± 2	G 1	47	M33x2	43	83	–	58	130	32	86	28
200	245 ± 2	G 1 1/4	58	M42x2	52	107.5	–	77.5	165	32	98	41.5

ØAL = Piston Ø

ØMM = Piston rod Ø

X* = Stroke length

1) Thread for piston rod ends "F" and "H"

2) Thread for piston rod ends "D" and "K"

3) For piston rod ends "E" and "T" see page 44

5) "H" dimension always in line connection position

6) For the position of the line connections and the bleeding see page 41

7) Tightening torque see page 63

12) Piston rod Ø not standardized

13) CG design: Piston rod marked with groove, only admissible for 50 bar tensile load

14) With operating pressures up to 210 bar only on request

Dimensions: Trunnion in center CTD3/CGT3: MT4 (dimensions in mm)

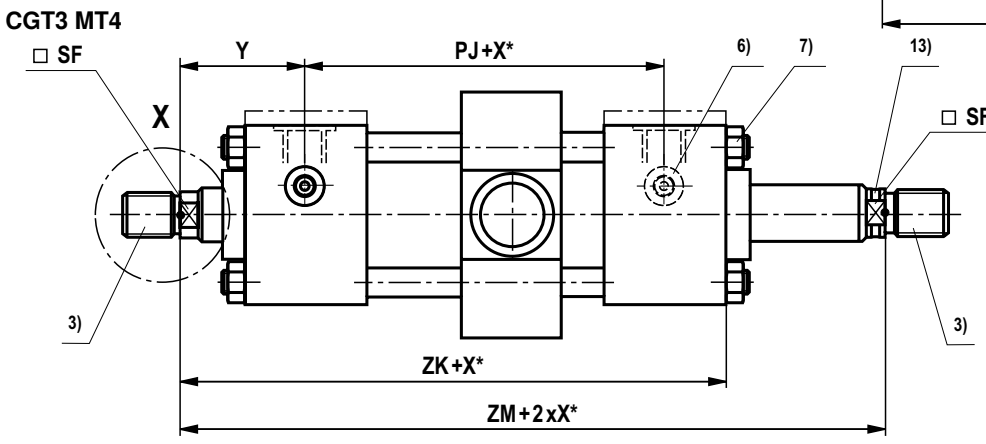
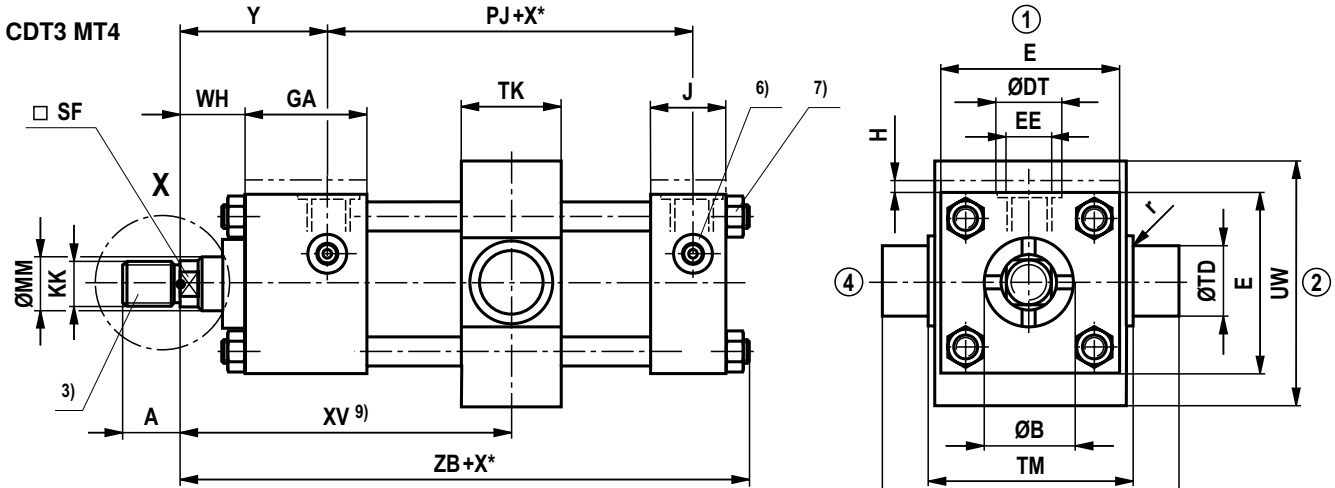

① ... ④ = Position of the line connections

We recommend lubricating the trunnions on a regular basis.

Dimensions for cylinder with piston rod extension "LY" in retracted condition.

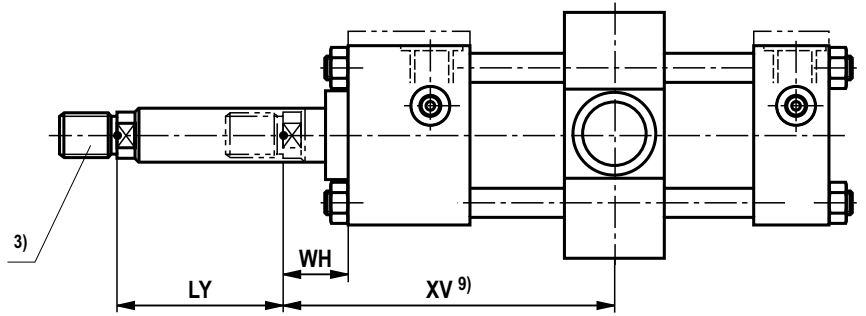
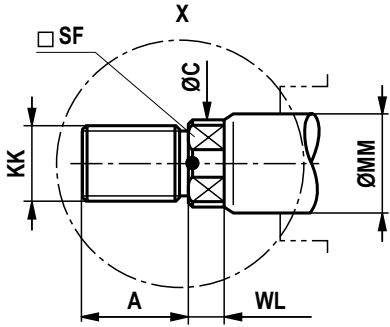

ØAL	r	ØTD f8	TK max	TM h14	UM h15	UW max	X* min	XV min	XV max	ZB max	ZK ± 1	ZM ± 2
25	1	12	20	48	68	43	0	74	80 + stroke	121	138	154
32	1	16	25	55	79	53	0	88	89 + stroke	137	151	177
40	1.6	20	30	76	108	74	0	95	104 + stroke	166	172	196
50	1.6	25	40	89	129	81	0	105	105 + stroke	176	183	207
63	2	32	50	100	150	97	10	117	107 + stroke	185	190	223
80	2.5	40	60	127	191	124	12	130	118 + stroke	212	216	246
100	2.5	50	70	140	220	137	18	142	124 + stroke	225	230	265
125	3.2	63	90	178	278	175	25	157	132 + stroke	260	254	289
160	3.2	80	110	215	341	221	40	171	131 + stroke	279	270	302
200	3.2	100	130	279	439	281	48	202	154 + stroke	336	329	361

Dimensions: Trunnion in center CTD3/CGT3: MT4 (dimensions in mm)

ØAL	ØMM	DIN / ISO ¹⁾ (for operating pressure up to 160 bar)					ISO ²⁾ (for operating pressure up to 210 bar)					ØB f9
		KK ¹⁾	A ¹⁾ max	ØC	SF	WL	KK ²⁾	A ²⁾ max	ØC	SF	WL	
25	12	M10x1.25	14	11	10	5	–	–	–	–	–	24
	18	M10x1.25	14	16.5	14	5	M14x1.5	18	16.5	14	5	30
32	14	M12x1.25	16	13	12	5	–	–	–	–	–	26
	22	M12x1.25	16	20.5	18	5	M16x1.5	22	20.5	18	5	34
40	18	M14x1.5	18	16.5	14	5	–	–	–	–	–	30
	22 ¹²⁾	M14x1.5	18	20.5	18	5	M16x1.5	22	20.5	18	5	34
	28	M14x1.5	18	26	22	7	M20x1.5	28	26	22	7	42
50	22	M16x1.5	22	20.5	18	5	–	–	–	–	–	34
	28 ¹²⁾	M16x1.5	22	26	22	7	M20x1.5	28	26	22	7	42
	36	M16x1.5	22	34	30	8	M27x2	36	34	30	8	50
63	28	M20x1.5	28	26	22	7	–	–	–	–	–	42
	36 ¹²⁾	M20x1.5	28	34	30	8	M27x2	36	34	30	8	50
	45	M20x1.5	28	43	36	10	M33x2	45	43	36	10	60
80	36	M27x2	36	34	30	8	–	–	–	–	–	50
	45 ¹²⁾	M27x2	36	43	36	10	M33x2	45	43	36	10	60
	56	M27x2	36	54	46	10	M42x2	56	54	46	10	72
100	45	M33x2	45	43	36	10	–	–	–	–	–	60
	56 ¹²⁾	M33x2	45	54	46	10	M42x2	56	54	46	10	72
	70	M33x2	45	68	60	15	M48x2	63	68	60	15	88
125	56	M42x2	56	54	46	10	–	–	–	–	–	72
	70 ¹²⁾	–	–	–	–	–	M48x2 ¹⁴⁾	63	68	60	15	88
	90	M42x2	56	86	75	15	M64x3 ¹⁴⁾	85	86	75	15	108
160	70	M48x2	63	68	60	15	–	–	–	–	–	88
	110	M48x2	63	106	92	18	M80x3 ¹⁴⁾	95	106	92	18	133
200	90	M64x3	85	86	75	15	–	–	–	–	–	108
	140	M64x3	85	136	125	18	M100x3 ¹⁴⁾	112	136	125	18	163

ØAL	E	EE	ØDT	EE	ØDT	GA	H ^{5; 11)}	J	PJ ± 1.25	WH ± 2	Y ± 2
25	40 ± 1.5	G 1/4	25	M14x1.5	21	46.5	5	22.5	53	15	50
32	45 ± 1.5	G 1/4	25	M14x1.5	21	48	5	25	56	25	60
40	63 ± 1.5	G 3/8	28	M18x1.5	26	52.5	–	33.5	73	25	62
50	75 ± 1.5	G 1/2	34	M22x1.5	29	57.5	–	33.5	74	25	67
63	90 ± 1.5	G 1/2	34	M22x1.5	29	57.5	–	35.5	80	32	71
80	115 ± 1.5	G 3/4	42	M27x2	34	67	–	41	93	31	77
100	130 ± 2	G 3/4	42	M27x2	34	70	–	43	101	35	82
125	165 ± 2	G 1	47	M33x2	43	76	–	54	117	35	86
160	205 ± 2	G 1	47	M33x2	43	83	–	58	130	32	86
200	245 ± 2	G 1 1/4	58	M42x2	52	107.5	–	77.5	165	32	98

ØAL = Piston Ø

ØMM = Piston rod Ø

X* = Stroke length

1) Thread for piston rod ends "F" and "H"

2) Thread for piston rod ends "D" and "K"

3) For piston rod ends "E" and "T" see page 44

5) "H" dimension always in line connection position

6) For the position of the line connections and the bleeding see page 41

7) Tightening torque see page 63

9) "XV" dimension in mm, always specify in the plain text

11) Piston Ø 25 and 32 mm: "H" dimension with line connection

12) Piston rod Ø not standardized

13) CG design: Piston rod marked with groove, only admissible for 50 bar tensile load

14) With operating pressures up to 210 bar only on request

Dimensions: Trunnion at head CDT3/CGT3; MT1 (dimensions in mm)

Trunnion at base CDT3; MT2 (dimensions in mm)

CDT3 MT1

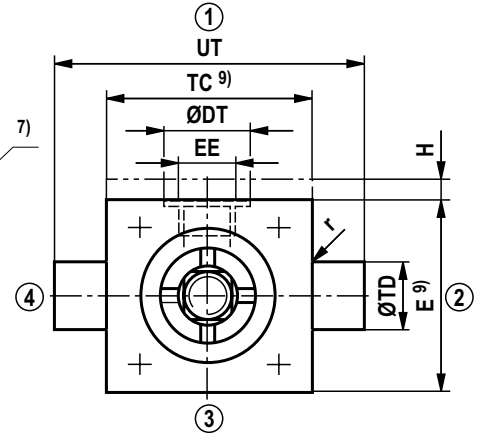
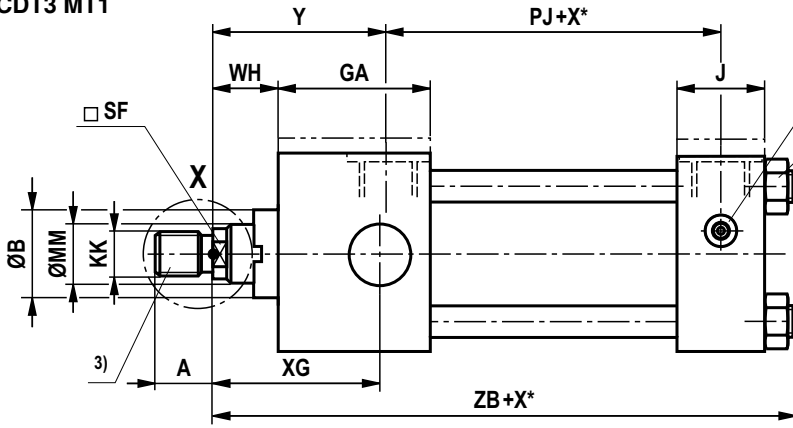

① ... ④ = Position of the line connections

CGT3 MT1

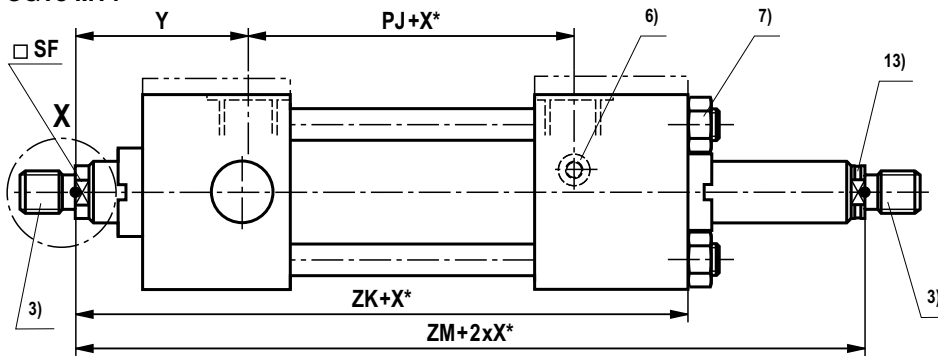

We recommend lubricating the trunnions on a regular basis.

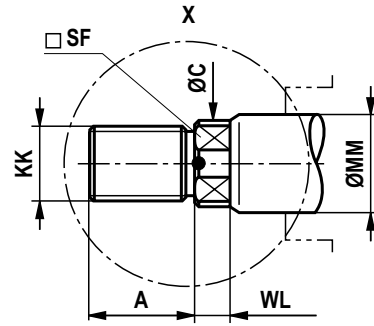

CDT3 MT2

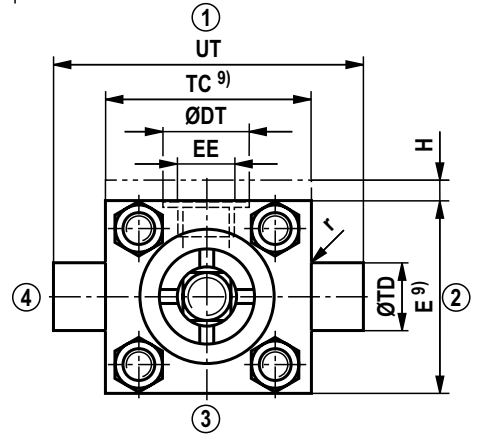
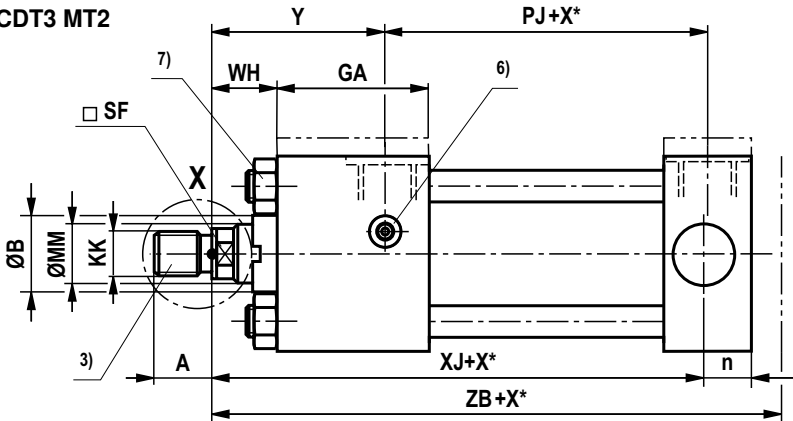

ØAL	n	r	TC h14	ØTD f8	UT h15	XG ± 2	XJ ± 1.25	ZB max	ZK ± 1	ZM ± 2
25	13	1	38	12	58	44	101	121	138	154
32	13	1	44	16	68	54	115	137	151	177
40	19	1.6	63	20	95	57	134	166	172	196
50	19	1.6	76	25	116	64	140	176	183	207
63	19	2	89	32	139	70	149	185	190	223
80	23	2.5	114	40	178	76	168	212	216	246
100	28	2.5	127	50	207	71	187	225	230	265
125	35	3.2	165	63	265	75	209	260	254	289
160	43	3.2	203	80	329	75	230	279	270	302
200	54.5	4.5	241	100	401	85	276	336	329	361

Dimensions: Trunnion at head CDT3/CGT3; MT1 (dimensions in mm)
Trunnion at base CDT3; MT2 (dimensions in mm)

ØAL	ØMM	DIN / ISO ¹⁾ (for operating pressure up to 160 bar)					ISO ²⁾ (for operating pressure up to 210 bar)					ØB f9
		KK ¹⁾	A ¹⁾ max	ØC	SF	WL	KK ²⁾	A ²⁾ max	ØC	SF	WL	
25	12	M10x1.25	14	11	10	5	–	–	–	–	–	24
	18	M10x1.25	14	16.5	14	5	M14x1.5	18	16.5	14	5	30
32	14	M12x1.25	16	13	12	5	–	–	–	–	–	26
	22	M12x1.25	16	20.5	18	5	M16x1.5	22	20.5	18	5	34
40	18	M14x1.5	18	16.5	14	5	–	–	–	–	–	30
	22 ¹²⁾	M14x1.5	18	20.5	18	5	M16x1.5	22	20.5	18	5	34
	28	M14x1.5	18	26	22	7	M20x1.5	28	26	22	7	42
50	22	M16x1.5	22	20.5	18	5	–	–	–	–	–	34
	28 ¹²⁾	M16x1.5	22	26	22	7	M20x1.5	28	26	22	7	42
	36	M16x1.5	22	34	30	8	M27x2	36	34	30	8	50
63	28	M20x1.5	28	26	22	7	–	–	–	–	–	42
	36 ¹²⁾	M20x1.5	28	34	30	8	M27x2	36	34	30	8	50
	45	M20x1.5	28	43	36	10	M33x2	45	43	36	10	60
80	36	M27x2	36	34	30	8	–	–	–	–	–	50
	45 ¹²⁾	M27x2	36	43	36	10	M33x2	45	43	36	10	60
	56	M27x2	36	54	46	10	M42x2	56	54	46	10	72
100	45	M33x2	45	43	36	10	–	–	–	–	–	60
	56 ¹²⁾	M33x2	45	54	46	10	M42x2	56	54	46	10	72
	70	M33x2	45	68	60	15	M48x2	63	68	60	15	88
125	56	M42x2	56	54	46	10	–	–	–	–	–	72
	70 ¹²⁾	–	–	–	–	–	M48x2 ¹⁴⁾	63	68	60	15	88
	90	M42x2	56	86	75	15	M64x3 ¹⁴⁾	85	86	75	15	108
160	70	M48x2	63	68	60	15	–	–	–	–	–	88
	110	M48x2	63	106	92	18	M80x3 ¹⁴⁾	95	106	92	18	133
200	90	M64x3	85	86	75	15	–	–	–	–	–	108
	140	M64x3	85	136	125	18	M100x3 ¹⁴⁾	112	136	125	18	163

ØAL	E	EE	ØDT	EE	ØDT	GA	H ⁵⁾	J	PJ ± 1.25	WH ± 2	Y ± 2
25	40 ± 1.5	G 1/4	25	M14x1.5	21	46.5	5	22.5	53	15	50
32	45 ± 1.5	G 1/4	25	M14x1.5	21	48	5	25	56	25	60
40	63 ± 1.5	G 3/8	28	M18x1.5	26	52.5	–	33.5	73	25	62
50	75 ± 1.5	G 1/2	34	M22x1.5	29	57.5	–	33.5	74	25	67
63	90 ± 1.5	G 1/2	34	M22x1.5	29	57.5	–	35.5	80	32	71
80	115 ± 1.5	G 3/4	42	M27x2	34	67	–	41	93	31	77
100	130 ± 2	G 3/4	42	M27x2	34	70	–	43	101	35	82
125	165 ± 2	G 1	47	M33x2	43	76	–	54	117	35	86
160	205 ± 2	G 1	47	M33x2	43	83	–	58	130	32	86
200	245 ± 2	G 1 1/4	58	M42x2	52	107.5	–	77.5	165	32	98

ØAL = Piston Ø

ØMM = Piston rod Ø

X* = Stroke length

1) Thread for piston rod ends "F" and "H"

2) Thread for piston rod ends "D" and "K"

3) For piston rod ends "E" and "T" see page 44

5) "H" dimension always in line connection position

6) For the position of the line connections and the bleeding see page 41

7) Tightening torque see page 63

9) With short strokes, observe "TC" and "E"

12) Piston rod Ø not standardized

13) CG design: Piston rod marked with groove, only admissible for 50 bar tensile load

14) With operating pressures up to 210 bar only on request

Dimensions: Extended tie rod, on both sides CDT3/CGT3; MX1 (dimensions in mm)

CDT3 MX1

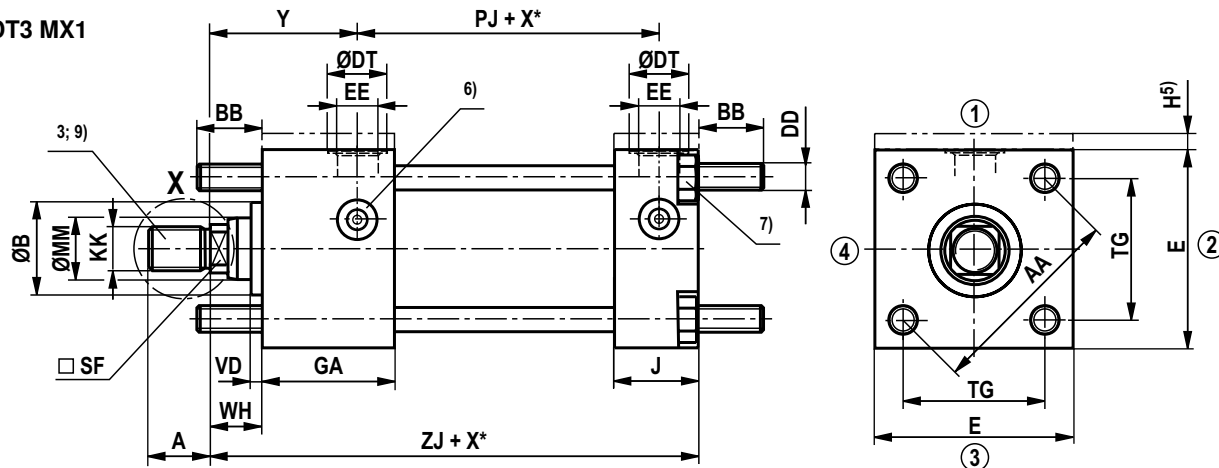

CGT3 MX1

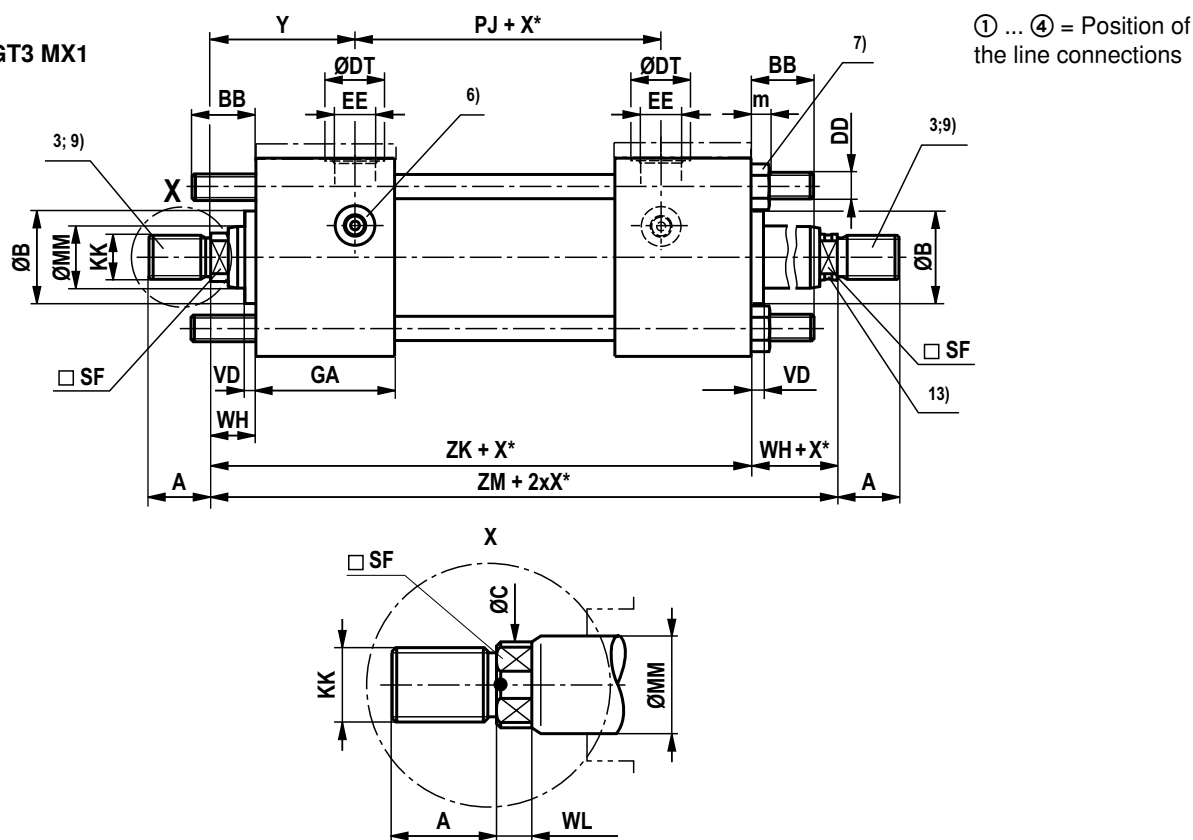

① ... ④ = Position of the line connections

ØAL	AA	BB ⁹⁾ + 3	TG js13	VD	ZJ ± 1.25	ZK ± 1	ZM ± 2
25	40	19	28.3	6	114	138	154
32	47	24	33.2	12	128	151	177
40	59	35	41.7	12	153	172	196
50	74	46	52.3	9	159	183	207
63	91	46	64.3	13	168	190	223
80	117	59	82.7	9	190	216	246
100	137	59	96.9	10	203	230	265
125	178	81	125.9	10	232	254	289
160	219	92	154.9	7	245	270	302
200	269	115	190.2	7	299	329	361

Dimensions: Extended tie rod, on both sides CDT3/CGT3; MX1 (dimensions in mm)

ØAL	ØMM	DIN / ISO ¹⁾ (for operating pressure up to 160 bar)					ISO ²⁾ (for operating pressure up to 210 bar)					ØB f9
		KK ¹⁾	A ¹⁾ max	ØC	SF	WL	KK ²⁾	A ²⁾ max	ØC	SF	WL	
25	12	M10x1.25	14	11	10	5	–	–	–	–	–	24
	18	M10x1.25	14	16.5	14	5	M14x1.5	18	16.5	14	5	30
32	14	M12x1.25	16	13	12	5	–	–	–	–	–	26
	22	M12x1.25	16	20.5	18	5	M16x1.5	22	20.5	18	5	34
40	18	M14x1.5	18	16.5	14	5	–	–	–	–	–	30
	22 ¹²⁾	M14x1.5	18	20.5	18	5	M16x1.5	22	20.5	18	5	34
	28	M14x1.5	18	26	22	7	M20x1.5	28	26	22	7	42
50	22	M16x1.5	22	20.5	18	5	–	–	–	–	–	34
	28 ¹²⁾	M16x1.5	22	26	22	7	M20x1.5	28	26	22	7	42
	36	M16x1.5	22	34	30	8	M27x2	36	34	30	8	50
63	28	M20x1.5	28	26	22	7	–	–	–	–	–	42
	36 ¹²⁾	M20x1.5	28	34	30	8	M27x2	36	34	30	8	50
	45	M20x1.5	28	43	36	10	M33x2	45	43	36	10	60
80	36	M27x2	36	34	30	8	–	–	–	–	–	50
	45 ¹²⁾	M27x2	36	43	36	10	M33x2	45	43	36	10	60
	56	M27x2	36	54	46	10	M42x2	56	54	46	10	72
100	45	M33x2	45	43	36	10	–	–	–	–	–	60
	56 ¹²⁾	M33x2	45	54	46	10	M42x2	56	54	46	10	72
	70	M33x2	45	68	60	15	M48x2	63	68	60	15	88
125	56	M42x2	54	54	46	10	–	–	–	–	–	72
	70 ¹²⁾	–	–	–	–	–	M48x2 ¹⁴⁾	63	68	60	15	88
	90	M42x2	56	86	75	15	M64x3 ¹⁴⁾	85	86	75	15	108
160	70	M48x2	63	68	60	15	–	–	–	–	–	88
	110	M48x2	63	106	92	18	M80x3 ¹⁴⁾	95	106	92	18	133
200	90	M64x3	85	86	75	15	–	–	–	–	–	108
	140	M64x3	85	136	125	18	M100x3 ¹⁴⁾	112	136	125	18	163

ØAL	DD	E	EE	ØDT	EE	ØDT	GA	H ⁵⁾	J	m	PJ ± 1.25	WH ± 2	Y ± 2
25	M5x0.8	40 ± 1.5	G 1/4	25	M14x1.5	21	46.5	5	22.5	4	53	15	50
32	M6x1	45 ± 1.5	G 1/4	25	M14x1.5	21	48	5	25	5	56	25	60
40	M8x1	63 ± 1.5	G 3/8	28	M18x1.5	26	52.5	–	33.5	6.5	73	25	62
50	M12x1.25	75 ± 1.5	G 1/2	34	M22x1.5	29	57.5	–	33.5	10	74	25	67
63	M12x1.25	90 ± 1.5	G 1/2	34	M22x1.5	29	57.5	–	35.5	10	80	32	71
80	M16x1.5	115 ± 1.5	G 3/4	42	M27x2	34	67	–	41	13	93	31	77
100	M16x1.5	130 ± 2	G 3/4	42	M27x2	34	70	–	43	13	101	35	82
125	M22x1.5	165 ± 2	G 1	47	M33x2	43	76	–	54	18	117	35	86
160	M27x2	205 ± 2	G 1	47	M33x2	43	83	–	58	22	130	32	86
200	M30x2	245 ± 2	G 1 1/4	58	M42x2	52	107.5	–	77.5	24	165	32	98

ØAL = Piston Ø

ØMM = Piston rod Ø

X* = Stroke length

1) Thread for piston rod ends "F" and "H"

2) Thread for piston rod ends "D" and "K"

3) For piston rod ends "E" and "T" see page 44

5) "H" dimension always in line connection position

6) For the position of the line connections and the bleeding see page 41

7) Tightening torque see page 63

9) Observe the "BB" dimension for the swivel head assembly

12) Piston rod Ø not standardized

13) CG design: Piston rod marked with groove, only admissible for 50 bar tensile load

14) With operating pressures up to 210 bar only on request

Dimensions: Extended tie rod at head CTD3; MX2 (dimensions in mm)
Extended tie rod at base CDT3/CGT3; MX3 (dimensions in mm)

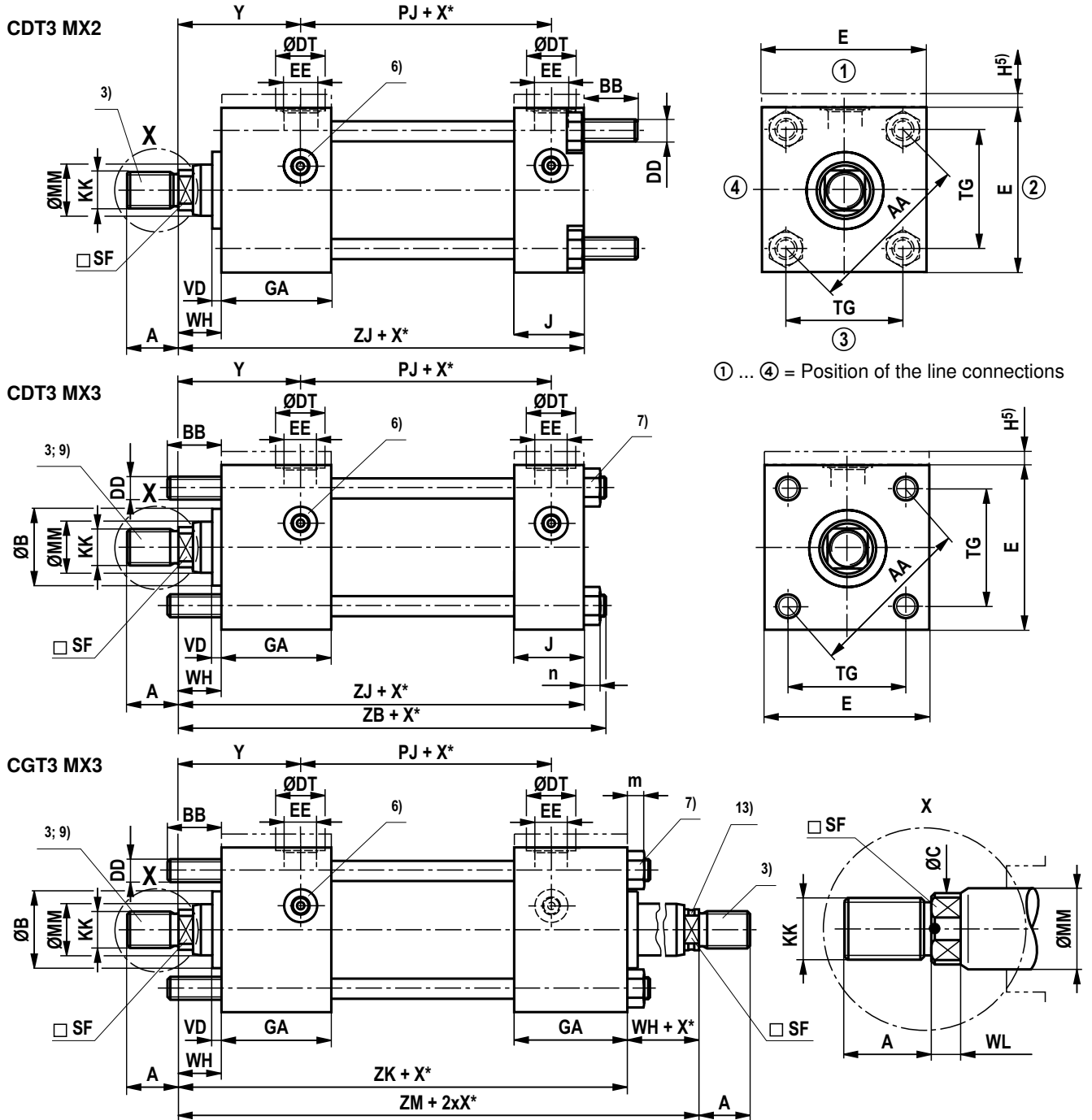

ØAL	AA	BB ⁹⁾ + 3	TG js13	VD	ZB max	ZJ ± 1	ZK ± 1	ZM ± 2
25	40	19	28.3	6	121	114	138	154
32	47	24	33.2	12	137	128	151	177
40	59	35	41.7	12	166	153	172	196
50	74	46	52.3	9	176	159	183	207
63	91	46	64.3	13	185	168	190	223
80	117	59	82.7	9	212	190	216	246
100	137	59	96.9	10	225	203	230	265
125	178	81	125.9	10	260	232	254	289
160	219	92	154.9	7	279	245	270	302
200	269	115	190.2	7	336	299	329	361

Dimensions: Extended tie rod at head CTD3; MX2 (dimensions in mm)
Extended tie rod at base CDT3/CGT3; MX3 (dimensions in mm)

ØAL	ØMM	DIN / ISO ¹⁾ (for operating pressure up to 160 bar)					ISO ²⁾ (for operating pressure up to 210 bar)					ØB f9
		KK ¹⁾	A ¹⁾ max	ØC	SF	WL	KK ²⁾	A ²⁾ max	ØC	SF	WL	
25	12	M10x1.25	14	11	10	5	–	–	–	–	–	24
	18	M10x1.25	14	16.5	14	5	M14x1.5	18	16.5	14	5	30
32	14	M12x1.25	16	13	12	5	–	–	–	–	–	26
	22	M12x1.25	16	20.5	18	5	M16x1.5	22	20.5	18	5	34
40	18	M14x1.5	18	16.5	14	5	–	–	–	–	–	30
	22 ¹²⁾	M14x1.5	18	20.5	18	5	M16x1.5	22	20.5	18	5	34
	28	M14x1.5	18	26	22	7	M20x1.5	28	26	22	7	42
50	22	M16x1.5	22	20.5	18	5	–	–	–	–	–	34
	28 ¹²⁾	M16x1.5	22	26	22	7	M20x1.5	28	26	22	7	42
	36	M16x1.5	22	34	30	8	M27x2	36	34	30	8	50
63	28	M20x1.5	28	26	22	7	–	–	–	–	–	42
	36 ¹²⁾	M20x1.5	28	34	30	8	M27x2	36	34	30	8	50
	45	M20x1.5	28	43	36	10	M33x2	45	43	36	10	60
80	36	M27x2	36	34	30	8	–	–	–	–	–	50
	45 ¹²⁾	M27x2	36	43	36	10	M33x2	45	43	36	10	60
	56	M27x2	36	54	46	10	M42x2	56	54	46	10	72
100	45	M33x2	45	43	36	10	–	–	–	–	–	60
	56 ¹²⁾	M33x2	45	54	46	10	M42x2	56	54	46	10	72
	70	M33x2	45	68	60	15	M48x2	63	68	60	15	88
125	56	M42x2	56	54	46	10	–	–	–	–	–	72
	70 ¹²⁾	–	–	–	–	–	M48x2 ¹⁴⁾	63	68	60	15	88
	90	M42x2	56	86	75	15	M64x3 ¹⁴⁾	85	86	75	15	108
160	70	M48x2	63	68	60	15	–	–	–	–	–	88
	110	M48x2	63	106	92	18	M80x3 ¹⁴⁾	95	106	92	18	133
200	90	M64x3	85	86	75	15	–	–	–	–	–	108
	140	M64x3	85	136	125	18	M100x3 ¹⁴⁾	112	136	125	18	163

ØAL	DD	E	EE	ØDT	EE	ØDT	GA	H ⁵⁾	J	m	PJ ± 1.25	WH ± 2	Y ± 2
25	M5x0.8	40 ± 1.5	G 1/4	25	M14x1.5	21	46.5	5	22.5	4	53	15	50
32	M6x1	45 ± 1.5	G 1/4	25	M14x1.5	21	48	5	25	5	56	25	60
40	M8x1	63 ± 1.5	G 3/8	28	M18x1.5	26	52.5	–	33.5	6.5	73	25	62
50	M12x1.25	75 ± 1.5	G 1/2	34	M22x1.5	29	57.5	–	33.5	10	74	25	67
63	M12x1.25	90 ± 1.5	G 1/2	34	M22x1.5	29	57.5	–	35.5	10	80	32	71
80	M16x1.5	115 ± 1.5	G 3/4	42	M27x2	34	67	–	41	13	93	31	77
100	M16x1.5	130 ± 2	G 3/4	42	M27x2	34	70	–	43	13	101	35	82
125	M22x1.5	165 ± 2	G 1	47	M33x2	43	76	–	54	18	117	35	86
160	M27x2	205 ± 2	G 1	47	M33x2	43	83	–	58	22	130	32	86
200	M30x2	245 ± 2	G 1 1/4	58	M42x2	52	107.5	–	77.5	24	165	32	98

ØAL = Piston Ø

ØMM = Piston rod Ø

X* = Stroke length

1) Thread for piston rod ends "F" and "H"

2) Thread for piston rod ends "D" and "K"

3) For piston rod ends "E" and "T" see page 44

5) "H" dimension always in line connection position

6) For the position of the line connections and the bleeding see page 41

7) Tightening torque see page 63

9) Observe the "BB" dimension for the swivel head assembly

12) Piston rod Ø not standardized

13) CG design: Piston rod marked with groove, only admissible for 50 bar tensile load

14) With operating pressures up to 210 bar only on request

Dimensions: Tapped hole at head CDT3/CGT3; MX5 (dimensions in mm)

CDT3 MX5

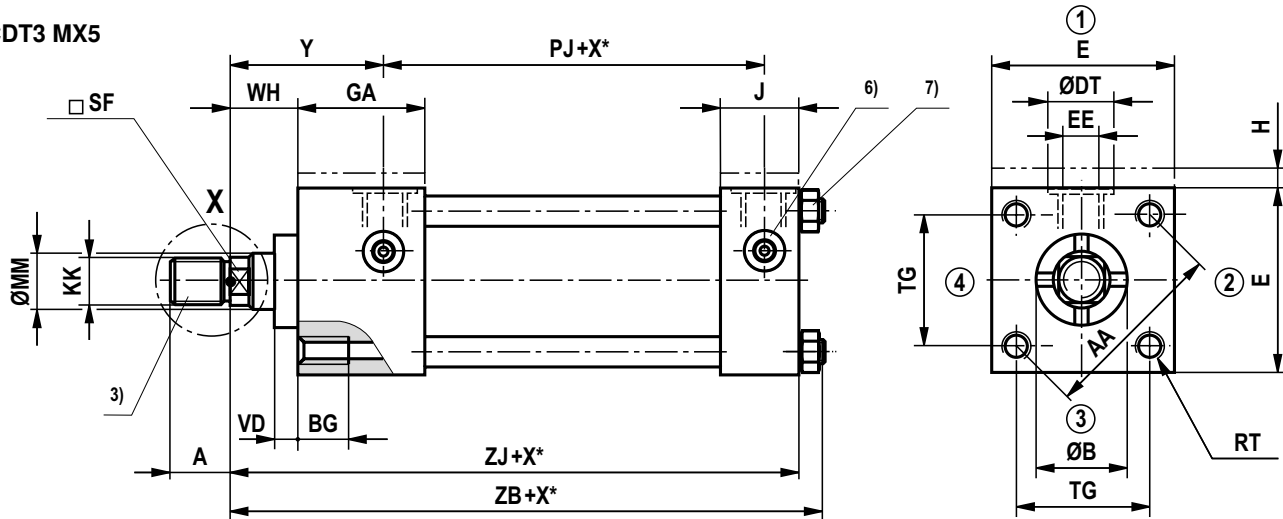

① ... ④ = Position of the line connections

CGT3 MX5

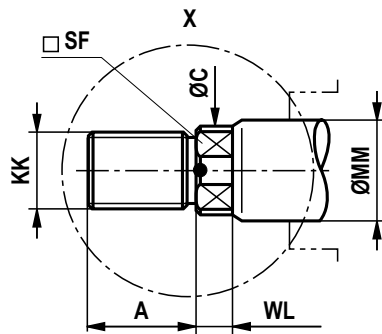
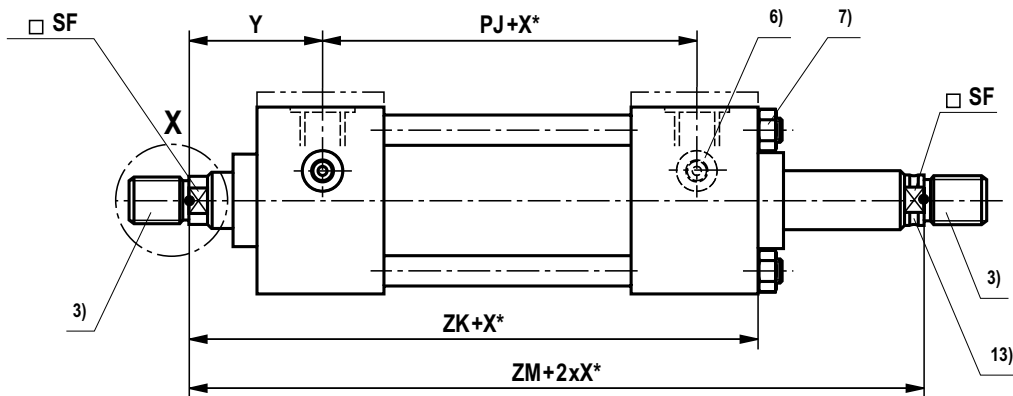

ØAL	AA	BG min	RT 6H	TG js13	VD	ZB max	ZJ ± 1.25	ZK ± 1	ZM ± 2
25	40	8	M5x0.8	28.3	6	121	114	138	154
32	47	9	M6x1	33.2	12	137	128	151	177
40	59	12	M8x1.25	41.7	12	166	153	172	196
50	74	18	M12x1.75	52.3	9	176	159	183	207
63	91	18	M12x1.75	64.3	13	185	168	190	223
80	117	24	M16x2	82.7	9	212	190	216	246
100	137	24	M16x2	96.9	10	225	203	230	265
125	178	27	M22x2.5	125.9	10	260	232	254	289
160	219	32	M27x3	154.9	7	279	245	270	302
200	269	40	M30x3.5	190.2	7	336	299	329	361

Dimensions: Tapped hole at head CDT3/CGT3; MX5 (dimensions in mm)

ØAL	ØMM	DIN / ISO ¹⁾ (for operating pressure up to 160 bar)					ISO ²⁾ (for operating pressure up to 210 bar)					ØB f9
		KK ¹⁾	A ¹⁾ max	ØC	SF	WL	KK ²⁾	A ²⁾ max	ØC	SF	WL	
25	12	M10x1.25	14	11	10	5	–	–	–	–	–	24
	18	M10x1.25	14	16.5	14	5	M14x1.5	18	16.5	14	5	30
32	14	M12x1.25	16	13	12	5	–	–	–	–	–	26
	22	M12x1.25	16	20.5	18	5	M16x1.5	22	20.5	18	5	34
40	18	M14x1.5	18	16.5	14	5	–	–	–	–	–	30
	22 ¹²⁾	M14x1.5	18	20.5	18	5	M16x1.5	22	20.5	18	5	34
	28	M14x1.5	18	26	22	7	M20x1.5	28	26	22	7	42
50	22	M16x1.5	22	20.5	18	5	–	–	–	–	–	34
	28 ¹²⁾	M16x1.5	22	26	22	7	M20x1.5	28	26	22	7	42
	36	M16x1.5	22	34	30	8	M27x2	36	34	30	8	50
63	28	M20x1.5	28	26	22	7	–	–	–	–	–	42
	36 ¹²⁾	M20x1.5	28	34	30	8	M27x2	36	34	30	8	50
	45	M20x1.5	28	43	36	10	M33x2	45	43	36	10	60
80	36	M27x2	36	34	30	8	–	–	–	–	–	50
	45 ¹²⁾	M27x2	36	43	36	10	M33x2	45	43	36	10	60
	56	M27x2	36	54	46	10	M42x2	56	54	46	10	72
100	45	M33x2	45	43	36	10	–	–	–	–	–	60
	56 ¹²⁾	M33x2	45	54	46	10	M42x2	56	54	46	10	72
	70	M33x2	45	68	60	15	M48x2	63	68	60	15	88
125	56	M42x2	56	54	46	10	–	–	–	–	–	72
	70 ¹²⁾	–	–	–	–	–	M48x2 ¹⁴⁾	63	68	60	15	88
	90	M42x2	56	86	75	15	M64x3 ¹⁴⁾	85	86	75	15	108
160	70	M48x2	63	68	60	15	–	–	–	–	–	88
	110	M48x2	63	106	92	18	M80x3 ¹⁴⁾	95	106	92	18	133
200	90	M64x3	85	86	75	15	–	–	–	–	–	108
	140	M64x3	85	136	125	18	M100x3 ¹⁴⁾	112	136	125	18	163

ØAL	E	EE	ØDT	EE	ØDT	GA	H ⁵⁾	J	PJ ± 1.25	WH ± 2	Y ± 2
25	40 ± 1.5	G 1/4	25	M14x1.5	21	46.5	5	22.5	53	15	50
32	45 ± 1.5	G 1/4	25	M14x1.5	21	48	5	25	56	25	60
40	63 ± 1.5	G 3/8	28	M18x1.5	26	52.5	–	33.5	73	25	62
50	75 ± 1.5	G 1/2	34	M22x1.5	29	57.5	–	33.5	74	25	67
63	90 ± 1.5	G 1/2	34	M22x1.5	29	57.5	–	35.5	80	32	71
80	115 ± 1.5	G 3/4	42	M27x2	34	67	–	41	93	31	77
100	130 ± 2	G 3/4	42	M27x2	34	70	–	43	101	35	82
125	165 ± 2	G 1	47	M33x2	43	76	–	54	117	35	86
160	205 ± 2	G 1	47	M33x2	43	83	–	58	130	32	86
200	245 ± 2	G 1 1/4	58	M42x2	52	107.5	–	77.5	165	32	98

ØAL = Piston Ø

ØMM = Piston rod Ø

X* = Stroke length

1) Thread for piston rod ends "F" and "H"

2) Thread for piston rod ends "D" and "K"

3) For piston rod ends "E" and "T" see page 44

5) "H" dimension always in line connection position

6) For the position of the line connections and the bleeding see page 41

7) Tightening torque see page 63

12) Piston rod Ø not standardized

13) CG design: Piston rod marked with groove, only admissible for 50 bar tensile load

14) With operating pressures up to 210 bar only on request

Dimensions: Type of mounting CDT3; MP1, MP3 (dimensions in mm)

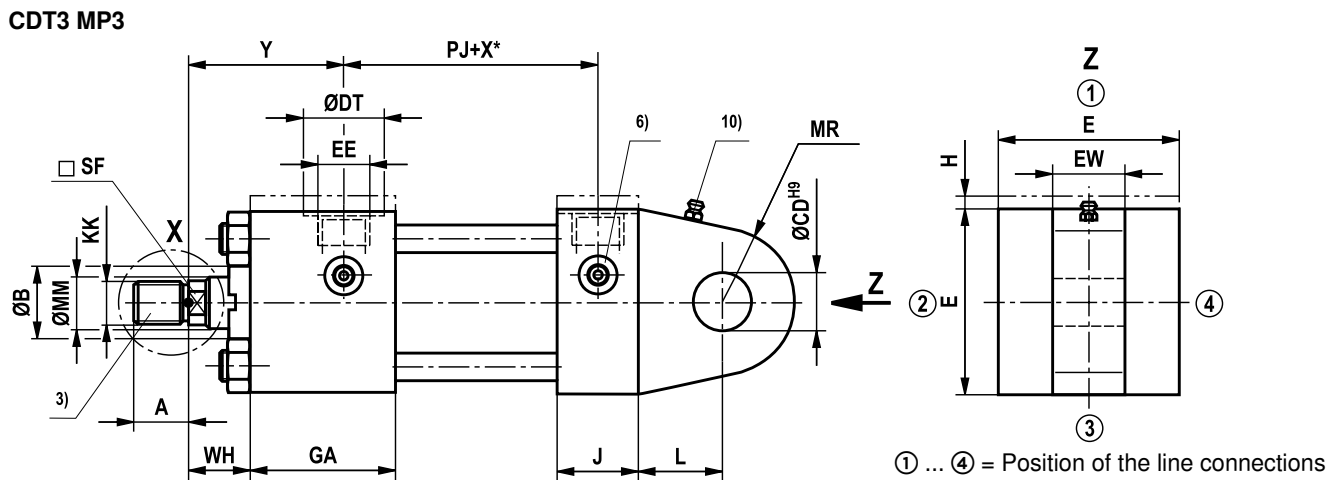
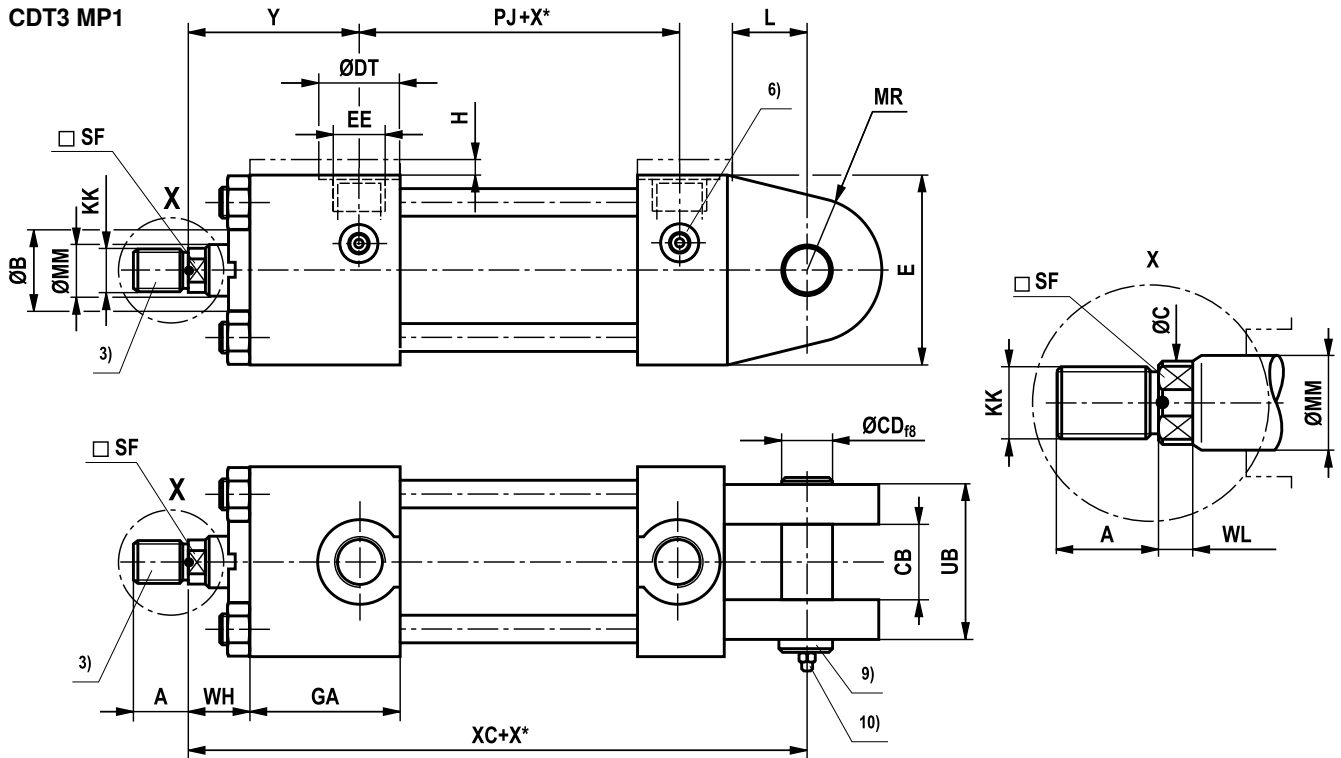

ØAL	CB A16	ØCD H9; f8	EW h14	L min	MR max	UB max	XC ± 1.25
25	12	10	12	13	12	25	127
32	16	12	16	19	17	34	147
40	20	14	20	19	17	42	172
50	30	20	30	32	29	62	191
63	30	20	30	32	29	62	200
80	40	28	40	39	34	83	229
100	50	36	50	54	50	103	257
125	60	45	60	57	53	120	289
160	70	56	70	63	59	140	308
200	80	70	80	82	78	160	381

Dimensions: Type of mounting CDT3; MP1, MP3 (dimensions in mm)

ØAL	ØMM	DIN / ISO ¹⁾ (for operating pressure up to 160 bar)					ISO ²⁾ (for operating pressure up to 210 bar)					ØB f9
		KK ¹⁾	A ¹⁾ max	ØC	SF	WL	KK ²⁾	A ²⁾ max	ØC	SF	WL	
25	12	M10x1.25	14	11	10	5	–	–	–	–	–	24
	18	M10x1.25	14	16.5	14	5	M14x1.5	18	16.5	14	5	30
32	14	M12x1.25	16	13	12	5	–	–	–	–	–	26
	22	M12x1.25	16	20.5	18	5	M16x1.5	22	20.5	18	5	34
40	18	M14x1.5	18	16.5	14	5	–	–	–	–	–	30
	22 ¹²⁾	M14x1.5	18	20.5	18	5	M16x1.5	22	20.5	18	5	34
	28	M14x1.5	18	26	22	7	M20x1.5	28	26	22	7	42
50	22	M16x1.5	22	20.5	18	5	–	–	–	–	–	34
	28 ¹²⁾	M16x1.5	22	26	22	7	M20x1.5	28	26	22	7	42
	36	M16x1.5	22	34	30	8	M27x2	36	34	30	8	50
63	28	M20x1.5	28	26	22	7	–	–	–	–	–	42
	36 ¹²⁾	M20x1.5	28	34	30	8	M27x2	36	34	30	8	50
	45	M20x1.5	28	43	36	10	M33x2	45	43	36	10	60
80	36	M27x2	36	34	30	8	–	–	–	–	–	50
	45 ¹²⁾	M27x2	36	43	36	10	M33x2	45	43	36	10	60
	56	M27x2	36	54	46	10	M42x2	56	54	46	10	72
100	45	M33x2	45	43	36	10	–	–	–	–	–	60
	56 ¹²⁾	M33x2	45	54	46	10	M42x2	56	54	46	10	72
	70	M33x2	45	68	60	15	M48x2	63	68	60	15	88
125	56	M42x2	56	54	46	10	–	–	–	–	–	72
	70 ¹²⁾	–	–	–	–	–	M48x2 ¹⁴⁾	63	68	60	15	88
	90	M42x2	56	86	75	15	M64x3 ¹⁴⁾	85	86	75	15	108
160	70	M48x2	63	68	60	15	–	–	–	–	–	88
	110	M48x2	63	106	92	18	M80x3 ¹⁴⁾	95	106	92	18	133
200	90	M64x3	85	86	75	15	–	–	–	–	–	108
	140	M64x3	85	136	125	18	M100x3 ¹⁴⁾	112	136	125	18	163

ØAL	E	EE	ØDT	EE	ØDT	GA	H ⁵⁾	J	PJ ± 1.25	WH ± 2	Y ± 2
25	40 ± 1.5	G 1/4	25	M14x1.5	21	46.5	5	22.5	53	15	50
32	45 ± 1.5	G 1/4	25	M14x1.5	21	48	5	25	56	25	60
40	63 ± 1.5	G 3/8	28	M18x1.5	26	52.5	–	33.5	73	25	62
50	75 ± 1.5	G 1/2	34	M22x1.5	29	57.5	–	33.5	74	25	67
63	90 ± 1.5	G 1/2	34	M22x1.5	29	57.5	–	35.5	80	32	71
80	115 ± 1.5	G 3/4	42	M27x2	34	67	–	41	93	31	77
100	130 ± 2	G 3/4	42	M27x2	34	70	–	43	101	35	82
125	165 ± 2	G 1	47	M33x2	43	76	–	54	117	35	86
160	205 ± 2	G 1	47	M33x2	43	83	–	58	130	32	86
200	245 ± 2	G 1 1/4	58	M42x2	52	107.5	–	77.5	165	32	98

ØAL = Piston Ø

ØMM = Piston rod Ø

X* = Stroke length

1) Thread for piston rod ends "F" and "H"

2) Thread for piston rod ends "D" and "K"

3) For piston rod ends "E" and "T" see page 44

5) "H" dimension always in line connection position

6) For the position of the line connections and the bleeding see page 41

7) Tightening torque see page 63

9) Bolt included in the scope of delivery

10) Lubricating nipple M6 DIN 71412

12) Piston rod Ø not standardized

14) With operating pressures up to 210 bar only on request

Areas, forces, flow: Series CST3 (for operating pressure up to 160 bar)

Piston \varnothing AL mm	Piston rod \varnothing MM mm	Area ratio φ A_1/A_3	Areas			Force at 160 bar ¹⁾			Flow at 0.1 m/s ²⁾			max. available stroke length (mm) ⁴⁾
			Piston A_1 cm ²	Rod A_2 cm ²	Ring A_3 cm ²	Pressure F_1 kN	Diff. F_2 kN	Pulling F_3 kN	Off q_{V1} l/min	Diff. q_{V2} l/min	Ein q_{V3} l/min	
40	28	1.96	12.56	6.16	6.40	20.11	9.85	10.25	7.5	3.7	3.8	1000
50	28 ³⁾	1.46	19.63	6.16	13.48	31.42	9.85	21.56	11.8	3.7	8.1	1200
	36	2.08		10.18	9.45							
63	36 ³⁾	1.48	31.17	10.18	20.99	49.88	16.29	33.59	18.7	6.1	12.6	1400
	45	2.04		15.90	15.27							
80	45 ³⁾	1.46	50.26	15.90	34.36	80.42	25.45	54.98	30.2	9.5	20.6	1700
	56	1.96		24.63	25.63							
100	56 ³⁾	1.46	78.54	24.63	53.91	125.66	39.41	86.26	47.1	14.8	32.3	2000
	70	1.96		38.48	40.06							
125	70 ³⁾	1.46	122.72	38.48	84.23	196.35	61.58	134.77	73.6	23.1	50.5	2300
	90	2.08		63.62	59.10							
160	70	1.25	201.06	38.48	162.58	321.70	61.58	260.12	120.6	23.1	97.5	2600
	110	1.90		95.03	106.03							
200	90	1.25	314.16	63.62	250.54	502.65	101.79	400.86	188.5	38.2	150.3	3000
	140	1.96		153.94	160.22							

¹⁾ Theoretical static cylinder force (without consideration of the efficiency and admissible load for attachment parts like e.g. swivel heads, plates or valves, etc.)

²⁾ Stroke velocity

³⁾ Piston rod \varnothing not standardized

⁴⁾ Larger stroke lengths upon request

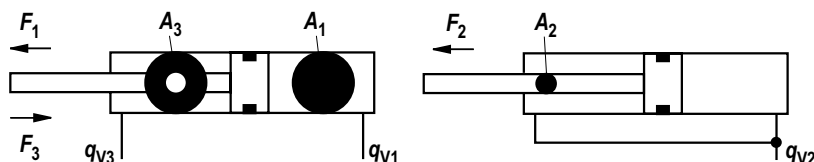
**Overview types of mounting: Series CST3** (Only for operating pressure up to 160 bar)**CST3 ME5**

see page 30, 31

**CST3 MP5**

see page 32, 33

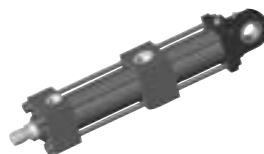
**CST3 MS2**

see page 34, 35

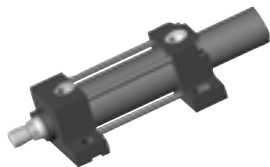
**CST3 MT4**

see page 36, 37

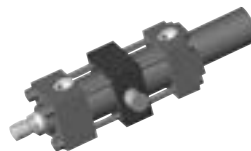
**CST3 MX5**

see page 38, 39



Ordering code: Series CST3 (for operating pressure up to 160 bar)

CS	T3	/	/	/	Z	3X											*
-----------	-----------	---	---	---	----------	-----------	--	--	--	--	--	--	--	--	--	--	----------

Differential cylinder with position measurement system ¹⁰⁾ = **CS**

Further details in the plain text

Series = **T3**

Types of mounting DIN/ISO

Rectangular flange at head = **ME5**
 Self-aligning clevis at base = **MP5**
 Foot mounting ⁸⁾ = **MS2**
 Trunnion in center ¹⁾ = **MT4**
 Tapped hole at head = **MX5**

Piston Ø (ØAL) 40 to 200 mm

Piston rod Ø (ØMM) 28 to 140 mm

Stroke length in mm ¹¹⁾

Design principle
 Head and base connected to tie rod = **Z**

Component series = **3X**
 30 to 39 unchanged installation and connection dimensions

Line connection/design

Pipe thread (ISO 1179-1) = **B**
 Subplate NG6 ^{8; 9)} = **P**
 Subplate NG10 ⁸⁾ = **T**
 Subplate NG16 ^{8; 15)} = **U**

Line connection/position at head
 see page 41

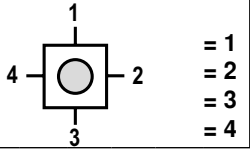

1 = 1
 2 = 2
 3 = 3
 4 = 4

View to piston rod

Option 2

C = Analog output 4-20 mA
F = Analog output 0-10 V
D = Digital output SSI

Option 1

T = Position measurement system (magnetostrictive) without mating connector
 Mating connector – separate order see page 46

Seal design

M = Standard seal system
T = Servo quality/Reduced friction
S = High temperature with reduced friction

End position cushioning

U = Without

Piston rod end
 see pages 30 to 39

H = Thread (DIN/ISO) for swivel head CGKA
D = Thread (ISO) for swivel head CGKA
F = With mounted swivel head CGKA (DIN/ISO)
K = With mounted swivel head CGKA (ISO)

Piston rod design

H = Hardened and hard chromium-plated

Line connection/position at base
 see page 41

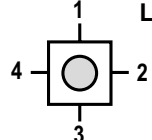

1 =
 2 =
 3 =
 4 =

View to piston rod

Order example:
CST3ME5/50/36/300Z2X/P11HDUTTD

When selecting, please observe the limitations on the corresponding catalog pages!

Comments:

- 1) Trunnion position freely selectable; when ordering, always specify the "XV" dimension in the plain text in mm.
- 8) Only position 11 possible
- 9) Only up to piston Ø 80 mm
- 10) Not standardized
- 11) Observe the max. and min. stroke length on pages 30 to 39 and the admissible stroke length (according to kinking calculation) on pages 52 to 55
- 15) Only piston Ø 100 – 200 mm

Dimensions: Rectangular flange at head CST3; ME5 (dimensions in mm)

CST3 ME5

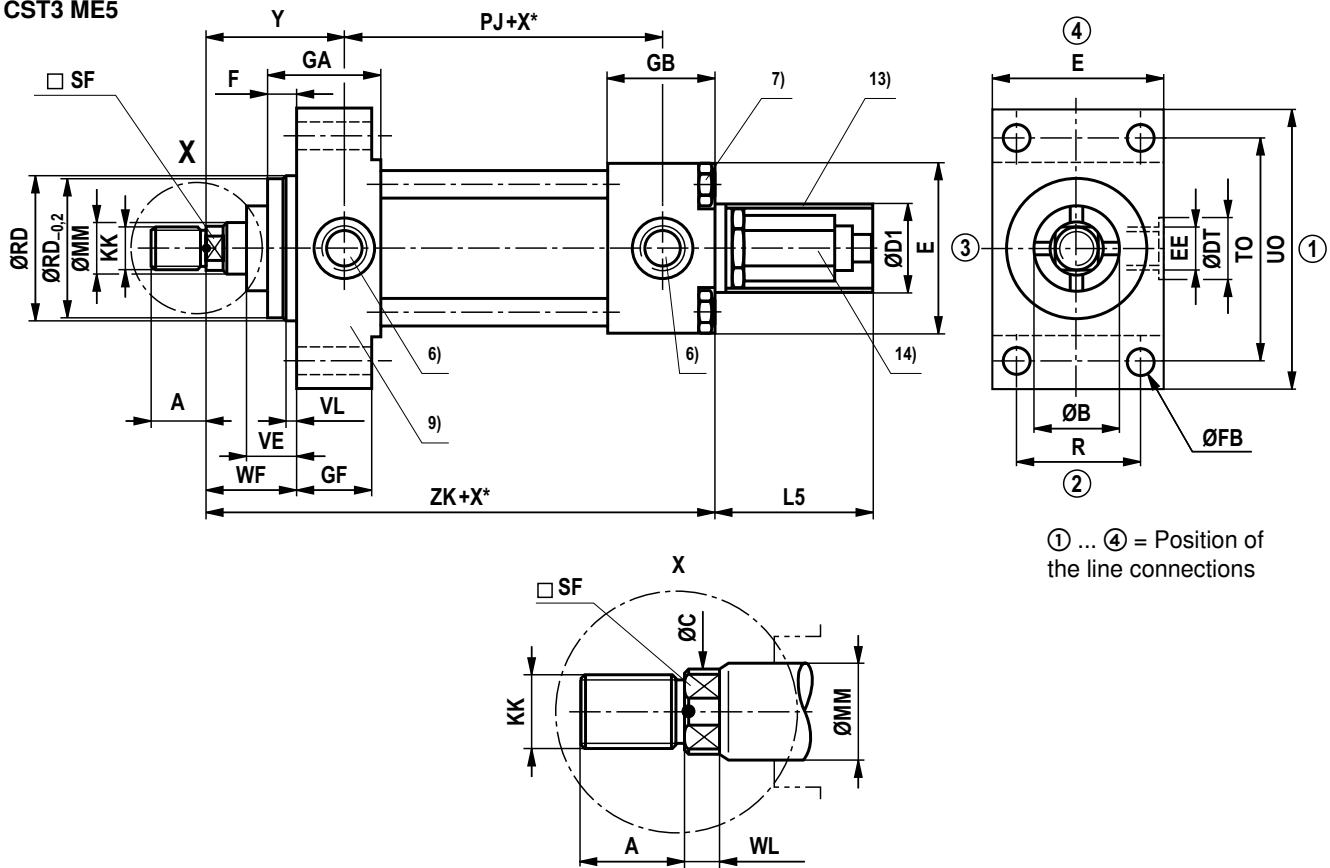

① ... ④ = Position of the line connections

ØAL	ØMM	PJ ¹⁰⁾ ± 1.25	PJ ¹¹⁾ ± 1.25	R JS13	TO JS13	UO max	VE max	VL min	ZK ± 1	L5	ØD1 max	X* min without subplate	X* min with subplate
40	28	73	77	41	87	110	22	3	195	-	-	-	50
50	28 36	74	78	52	105	130	25	4	194	-	-	-	50
63	36 45	80	81	65	117	145	29	4	205	82	96	-	45
80	45 56	93	93	83	149	180	29	4	234	82	96	-	32
100	56 70	101	101	97	162	200	32	5	248	82	96	-	57
125	70 90	117	117	126	208	250	32	5	265.5	82	96	-	35
160	70 110	130	130	155	253	300	32	5	277	82	96	20	20
200	90 140	165	160	190	300	360	32	5	326.5	82	96	20	20

Dimensions: Rectangular flange at head CST3; ME5 (dimensions in mm)

ØAL	ØMM	DIN / ISO ¹⁾					ISO ²⁾					ØB f9	ØRD f8
		KK ¹⁾	A ¹⁾ max	ØC	SF	WL	KK ²⁾	A ²⁾ max	ØC	SF	WL		
40	28	M14x1.5	18	26	22	7	M20x1.5	28	26	22	7	42	62
50	28	M16x1.5	22	26	22	7	M20x1.5	28	26	22	7	42	74
	36	M16x1.5	22	34	30	8	M27x2	36	34	30	8	50	74
63	36	M20x1.5	28	34	30	8	M27x2	36	34	30	8	50	88
	45	M20x1.5	28	43	36	10	M33x2	45	43	36	10	60	88
80	45	M27x2	36	43	36	10	M33x2	45	43	36	10	60	105
	56	M27x2	36	54	46	10	M42x2	56	54	46	10	72	105
100	56	M33x2	45	54	46	10	M42x2	56	54	46	10	72	125
	70	M33x2	45	68	60	15	M48x2	63	68	60	15	88	125
125	70	–	–	–	–	–	M48x2	63	68	60	15	88	150
	90	M42x2	56	86	75	15	M64x3	85	86	75	15	108	150
160	70	M48x2	63	68	60	15	–	–	–	–	–	88	125
	110	M48x2	63	106	92	18	M80x3	95	106	92	18	133	170
200	90	M64x3	85	86	75	15	–	–	–	–	–	108	150
	140	M64x3	85	136	125	18	M100x3	112	136	125	18	163	210

ØAL	F max	ØFB H13	GF ⁹⁾	E	EE	ØDT	GA	GB	WF ± 2	Y ¹⁰⁾ ± 2	Y ¹¹⁾ ± 2
40	10	11	38	63 ± 1.5	G 3/8	28	52.5	75.5	35	62	58
50	16	14	38	75 ± 1.5	G 1/2	34	57.5	68.5	41	67	63
63	16	14	38	90 ± 1.5	G 1/2	34	57.5	72.5	48	71	70
80	20	18	45	115 ± 1.5	G 3/4	42	67	85	51	77	77
100	22	18	45	130 ± 2	G 3/4	42	70	88	57	82	82
125	22	22	58	165 ± 2	G 1	47	80	87.5	57	86	86
160	25	26	58	205 ± 2	G 1	47	83	90	57	86	86
200	25	33	76	245 ± 2	G 1 1/4	58	101	105	57	98	98

ØAL = Piston Ø

ØMM = Piston rod Ø

X* = Stroke length

X*min = min. stroke length

X*max = max. stroke length

1) Thread for piston rod ends "F" and "H"

2) Thread for piston rod ends "D" and "K"

6) For the position of the line connections and the bleeding see page 41

7) Tightening torque see page 63

9) Flange thickness according to DIN 24554

10) ME5: for line connection position "1" and "3" at head

11) ME5: for line connection position "2" and "4" at head

13) With piston Ø 40 – 50 mm without protective pipe

14) Installation space for position measurement system at least 200 mm

Dimensions: Self-aligning clevis at base CST3; MP5 (dimensions in mm)

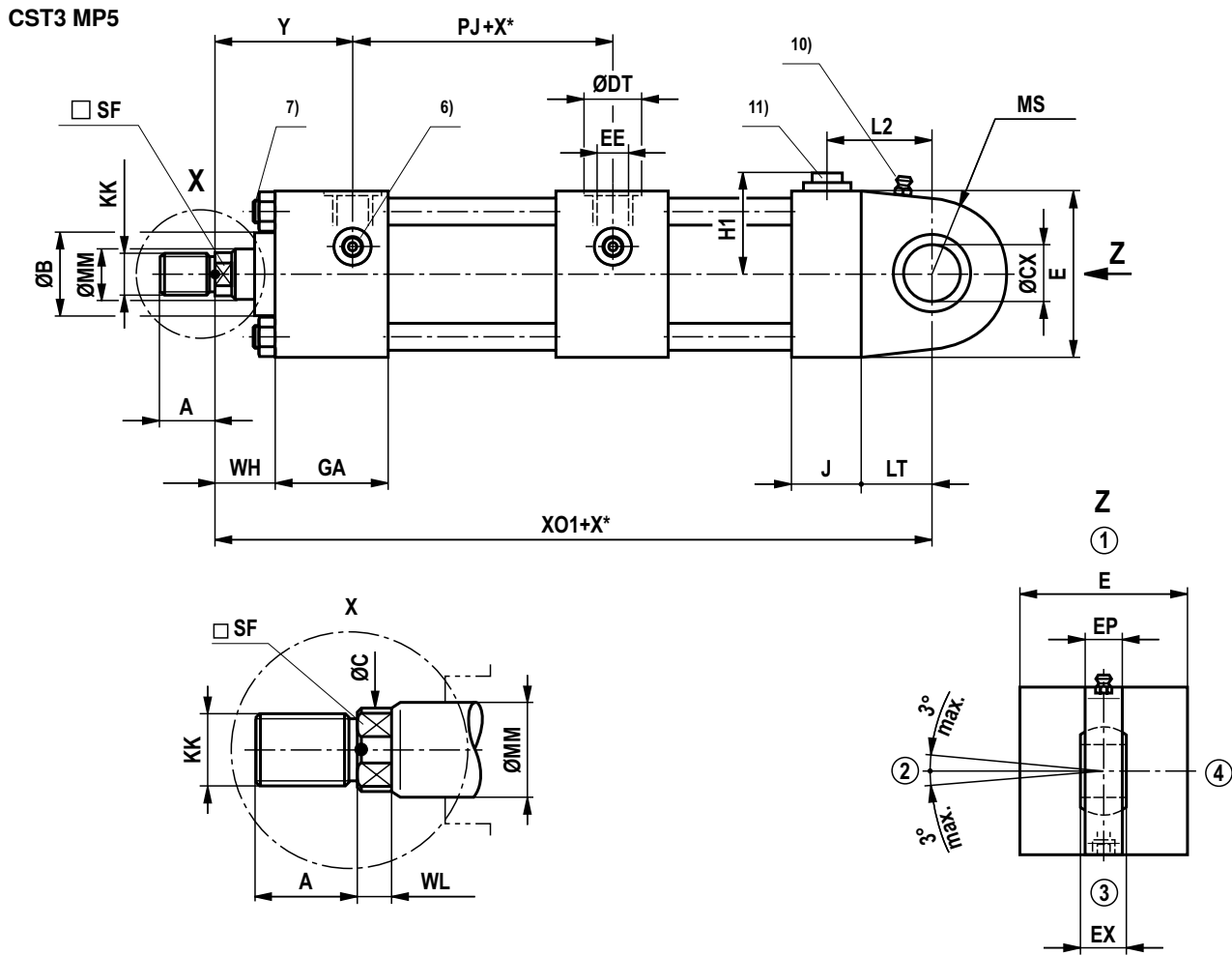

① ... ④ = Position of the line connections

ØAL	ØMM	ØCX	EP h13	EX	LT min	XO1 ± 1.5	MS max	X* min without subplate	X* min with subplate
40	28	20 - 0.012	13	16 - 0.12	25	348	29	-	50
50	28 36	25 - 0.012	17	20 - 0.12	31	365	33	-	50
63	36 45	30 - 0.012	19	22 - 0.12	38	383	40	-	45
80	45 56	40 - 0.012	23	28 - 0.12	48	410	50	-	32
100	56 70	50 - 0.012	30	35 - 0.12	58	436	62	-	57
125	70 90	60 - 0.015	38	44 - 0.15	72	487	80	-	35
160	70 110	80 - 0.015	47	55 - 0.15	92	528	100	20	20
200	90 140	100 - 0.020	57	70 - 0.20	116	632	120	20	20

Dimensions: Self-aligning clevis at base CST3; MP5 (dimensions in mm)

ØAL	ØMM	DIN / ISO ¹⁾					ISO ²⁾					ØB f9
		KK ¹⁾	A ¹⁾ max	ØC	SF	WL	KK ²⁾	A ²⁾ max	ØC	SF	WL	
40	28	M14x1.5	18	26	22	7	M20x1.5	28	26	22	7	42
50	28	M16x1.5	22	26	22	7	M20x1.5	28	26	22	7	42
	36	M16x1.5	22	34	30	8	M27x2	36	34	30	8	50
63	36	M20x1.5	28	34	30	8	M27x2	36	34	30	8	50
	45	M20x1.5	28	43	36	10	M33x2	45	43	36	10	60
80	45	M27x2	36	43	36	10	M33x2	45	43	36	10	60
	56	M27x2	36	54	46	10	M42x2	56	54	46	10	72
100	56	M33x2	45	54	46	10	M42x2	56	54	46	10	72
	70	M33x2	45	68	60	15	M48x2	63	68	60	15	88
125	70	–	–	–	–	–	M48x2	63	68	60	15	88
	90	M42x2	56	86	75	15	M64x3	85	86	75	15	108
160	70	M48x2	63	68	60	15	–	–	–	–	–	88
	110	M48x2	63	106	92	18	M80x3	95	106	92	18	133
200	90	M64x3	85	86	75	15	–	–	–	–	–	108
	140	M64x3	85	136	125	18	M100x3	112	136	125	18	163

ØAL	H1	L2	E	EE	ØDT	GA	J	PJ ± 1.25	WH ± 2	Y ± 2
40	40	43.5	63 ± 1.5	G 3/8	28	52.5	33.5	73	25	62
50	45.5	49	75 ± 1.5	G 1/2	34	57.5	33.5	74	25	67
63	53	55	90 ± 1.5	G 1/2	34	57.5	35.5	80	32	71
80	65.5	68	115 ± 1.5	G 3/4	42	67	41	93	31	77
100	73	78	130 ± 2	G 3/4	42	70	43	101	35	82
125	90.5	101	165 ± 2	G 1	47	76	54	117	35	86
160	110.5	120.5	205 ± 2	G 1	47	83	58	130	32	86
200	130.5	157	245 ± 2	G 1 1/4	58	107.5	77.5	165	32	98

ØAL = Piston Ø

ØMM = Piston rod Ø

X* = Stroke length

X*min = min. stroke length

X*max = max. stroke length

1) Thread for piston rod ends "F" and "H"

2) Thread for piston rod ends "D" and "K"

6) For the position of the line connections and the bleeding see page 41

7) Tightening torque see page 63

10) Lubricating nipple M6 DIN 71412

11) Only in line connection position 1 at base

Dimensions: Foot mounting CST3; MS2 (dimensions in mm)

CST3 MS2

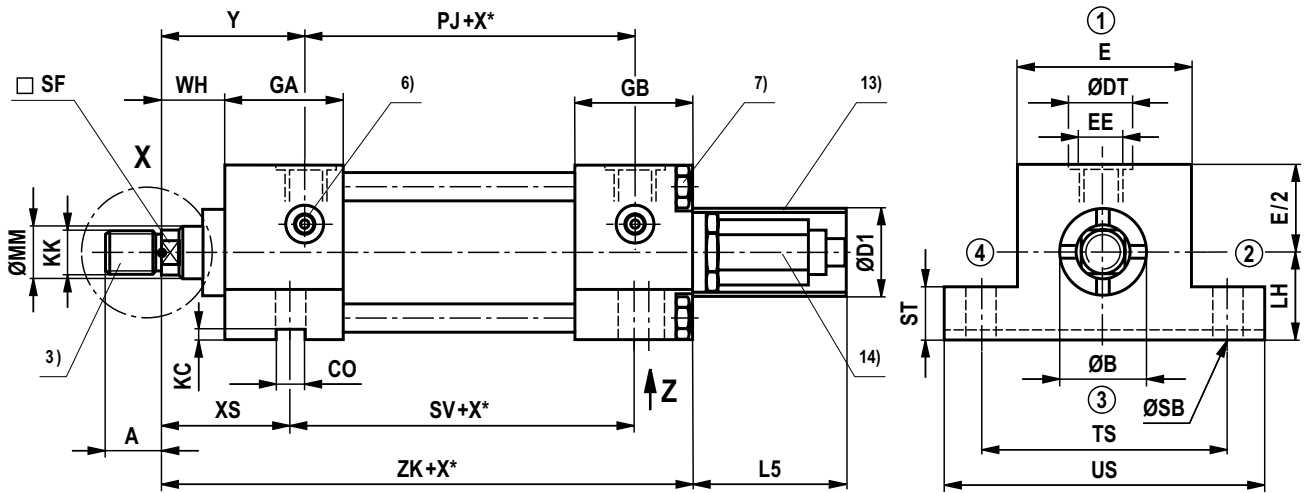

① ... ④ = Position of the line connections

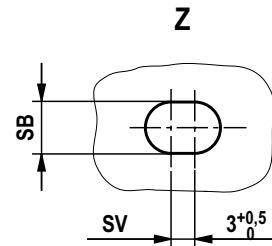
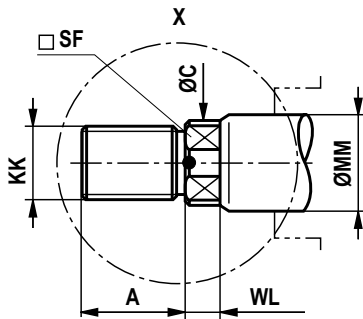

ØAL	CO N9	KC +0.2 0	LH h10	PJ ± 1.25	ØSB H13	ST	SV ± 1	TS JS13	US max
40	12	4	31	73	11	12.5	106.5	83	103
50	12	4.5	37	74	14	19	99.5	102	127
63	16	4.5	44	80	18	26	91.5	124	161
80	16	5	57	93	18	26	110.5	149	186
100	16	6	63	101	26	32	106.5	172	216
125	20	6	82	117	26	32	128.5	210	254
160	30	8	101	130	33	38	129	260	318
200	40	8	122	165	39	44	171	311	381

Dimensions: Foot mounting CST3; MS2 (dimensions in mm)

ØAL	ØMM	DIN / ISO ¹⁾					ISO ²⁾					ØB f9
		KK ¹⁾	A ¹⁾ max	ØC	SF	WL	KK ²⁾	A ²⁾ max	ØC	SF	WL	
40	28	M14x1.5	18	26	22	7	M20x1.5	28	26	22	7	42
50	28	M16x1.5	22	26	22	7	M20x1.5	28	26	22	7	42
	36	M16x1.5	22	34	30	8	M27x2	36	34	30	8	50
63	36	M20x1.5	28	34	30	8	M27x2	36	34	30	8	50
	45	M20x1.5	28	43	36	10	M33x2	45	43	36	10	60
80	45	M27x2	36	43	36	10	M33x2	45	43	36	10	60
	56	M27x2	36	54	46	10	M42x2	56	54	46	10	72
100	56	M33x2	45	54	46	10	M42x2	56	54	46	10	72
	70	M33x2	45	68	60	15	M48x2	63	68	60	15	88
125	70	–	–	–	–	–	M48x2	63	68	60	15	88
	90	M42x2	56	86	75	15	M64x3	85	86	75	15	108
160	70	M48x2	63	68	60	15	–	–	–	–	–	88
	110	M48x2	63	106	92	18	M80x3	95	106	92	18	133
200	90	M64x3	85	86	75	15	–	–	–	–	–	108
	140	M64x3	85	136	125	18	M100x3	112	136	125	18	163

ØAL	E	EE	ØDT	GA	GB	WH ± 2	Y ± 2
40	63 ± 1.5	G 3/8	28	52.5	75.5	25	62
50	75 ± 1.5	G 1/2	34	57.5	68.5	25	67
63	90 ± 1.5	G 1/2	34	57.5	72.5	32	71
80	115 ± 1.5	G 3/4	42	67	85	31	77
100	130 ± 2	G 3/4	42	70	88	35	82
125	165 ± 2	G 1	47	76	87.5	35	86
160	205 ± 2	G 1	47	83	90	32	86
200	245 ± 2	G 1 1/4	58	107.5	105	32	98

ØAL	ØMM	XS ± 2	ZK ± 1	L5	ØD1 max	X* min without subplate	X* min with subplate
40	28	45	195	–	–	–	50
50	28	54	194	–	–	–	50
	36						
63	36	65	205	82	96	–	45
	45						
80	45	68	234	82	96	–	32
	56						
100	56	79	248	82	96	–	57
	70						
125	70	79	265.5	82	96	–	35
	90						
160	70	86	277	82	96	20	20
	110						
200	90	92	326.5	82	96	20	20
	140						

ØAL = Piston Ø

ØMM = Piston rod Ø

X* = Stroke length

X*min = min. stroke length

X*max = max. stroke length

1) Thread for piston rod ends "F" and "H"

2) Thread for piston rod ends "D" and "K"

6) For the position of the line connections and the bleeding see page 41

7) Tightening torque see page 63

13) With piston Ø 40 – 50 mm without protective pipe

14) Installation space for position measurement system at least 200 mm

Dimensions: Trunnion in the center CST3; MT4 (dimensions in mm)

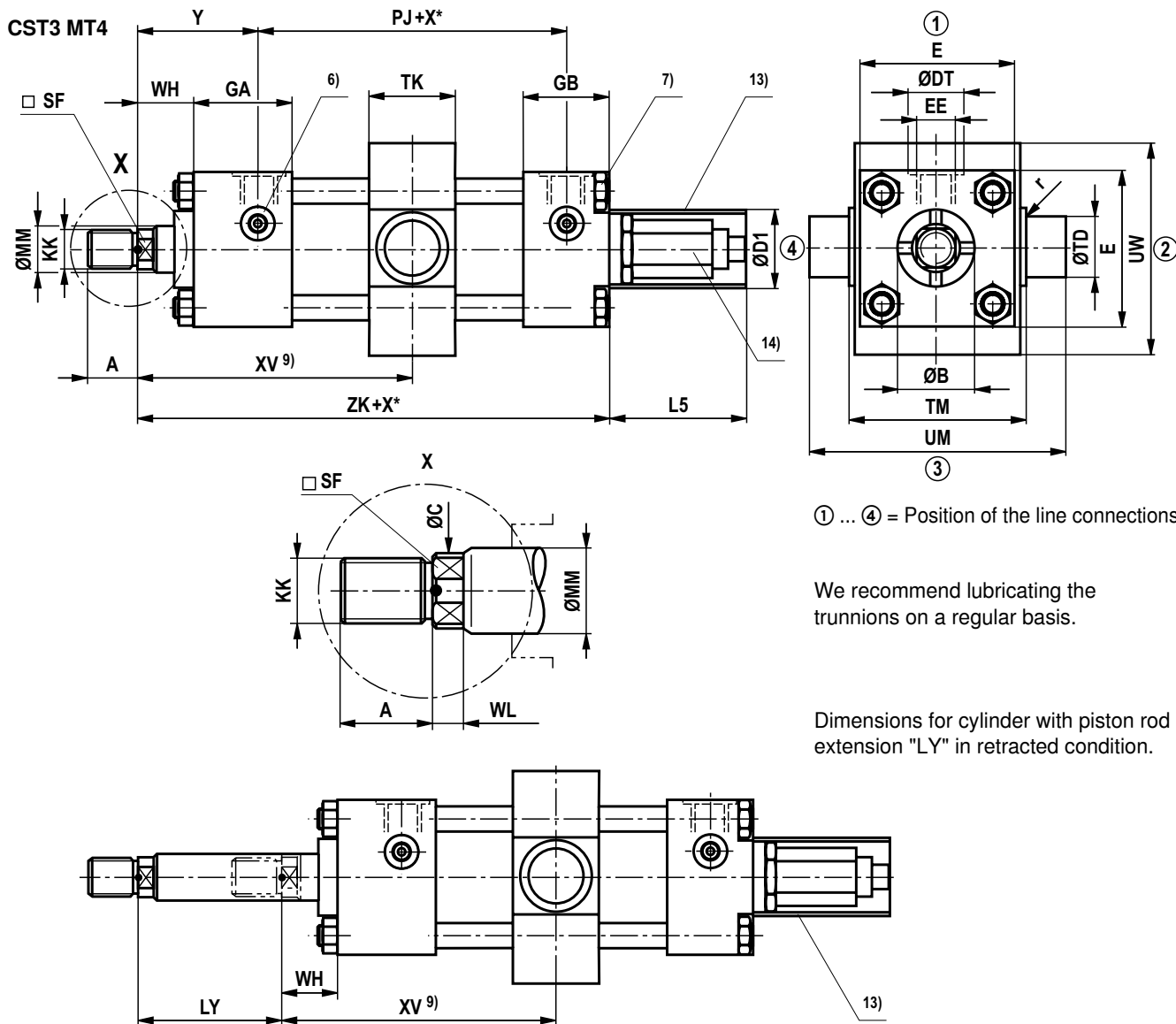

① ... ④ = Position of the line connections

We recommend lubricating the trunnions on a regular basis.

Dimensions for cylinder with piston rod extension "LY" in retracted condition.

ØAL	ØMM	Line connection "B"			Line connection "P", "T", "U"			ZK ± 1	L5	ØD1 max
		X* min	XV min ± 2	XV max ± 2	X* min	XV min ± 2	XV max ± 2			
40	28	-	95	104 + stroke	50	95	76 + stroke	195	-	-
50	28 36	-	105	105 + stroke	50	105	77 + stroke	194	-	-
63	36 45	10	117	107 + stroke	45	117	82 + stroke	205	82	96
80	45 56	12	130	118 + stroke	35	130	96 + stroke	234	82	96
100	56 70	18	142	124 + stroke	57	142	101 + stroke	248	82	96
125	70 90	25	157	132 + stroke	63	157	94 + stroke	265.5	82	96
160	70 110	40	171	131 + stroke	74	171	97 + stroke	277	82	96
200	90 140	48	202	154 + stroke	73	202	129 + stroke	326.5	82	96

Dimensions: Trunnion in the center CST3; MT4 (dimensions in mm)

ØAL	ØMM	DIN / ISO ¹⁾					ISO ²⁾					ØB f9
		KK ¹⁾	A ¹⁾ max	ØC	SF	WL	KK ²⁾	A ²⁾ max	ØC	SF	WL	
40	28	M14x1.5	18	26	22	7	M20x1.5	28	26	22	7	42
50	28	M16x1.5	22	26	22	7	M20x1.5	28	26	22	7	42
	36	M16x1.5	22	34	30	8	M27x2	36	34	30	8	50
63	36	M20x1.5	28	34	30	8	M27x2	36	34	30	8	50
	45	M20x1.5	28	43	36	10	M33x2	45	43	36	10	60
80	45	M27x2	36	43	36	10	M33x2	45	43	36	10	60
	56	M27x2	36	54	46	10	M42x2	56	54	46	10	72
100	56	M33x2	45	54	46	10	M42x2	56	54	46	10	72
	70	M33x2	45	68	60	15	M48x2	63	68	60	15	88
125	70	–	–	–	–	–	M48x2	63	68	60	15	88
	90	M42x2	56	86	75	15	M64x3	85	86	75	15	108
160	70	M48x2	63	68	60	15	–	–	–	–	–	88
	110	M48x2	63	106	92	18	M80x3	95	106	92	18	133
200	90	M64x3	85	86	75	15	–	–	–	–	–	108
	140	M64x3	85	136	125	18	M100x3	112	136	125	18	163

ØAL	PJ ±1.25	TK max	TM h14	UM h15	UW max	r	ØTD f8	E	EE	ØDT	GA	GB	WH ±2	Y ±2
40	73	30	76	108	74	1.6	20	63 ± 1.5	G 3/8	28	52.5	75.5	25	62
50	74	40	89	129	81	1.6	25	75 ± 1.5	G 1/2	34	57.5	68.5	25	67
63	80	50	100	150	97	2.0	32	90 ± 1.5	G 1/2	34	57.5	72.5	32	71
80	93	60	127	191	124	2.5	40	115 ± 1.5	G 3/4	42	67	85	31	77
100	101	70	140	220	137	2.5	50	130 ± 2	G 3/4	42	70	88	35	82
125	117	90	178	278	175	3.2	63	165 ± 2	G 1	47	76	87.5	35	86
160	130	110	215	341	221	3.2	80	205 ± 2	G 1	47	83	90	32	86
200	160	130	279	439	281	3.2	100	245 ± 2	G 1 1/4	58	107.5	105	32	98

ØAL = Piston Ø

ØMM = Piston rod Ø

X* = Stroke length

X*min = min. stroke length

X*max = max. stroke length

1) Thread for piston rod ends "F" and "H"

2) Thread for piston rod ends "D" and "K"

6) For the position of the line connections and the bleeding see page 41

7) Tightening torque see page 63

9) "XV" dimension in mm, always specify in the plain text

13) With piston Ø 40 – 50 mm without protective pipe

14) Installation space for position measurement system at least 200 mm

Dimensions: Tapped hole at head CST3; MX5 (dimensions in mm)

CST3 MX5

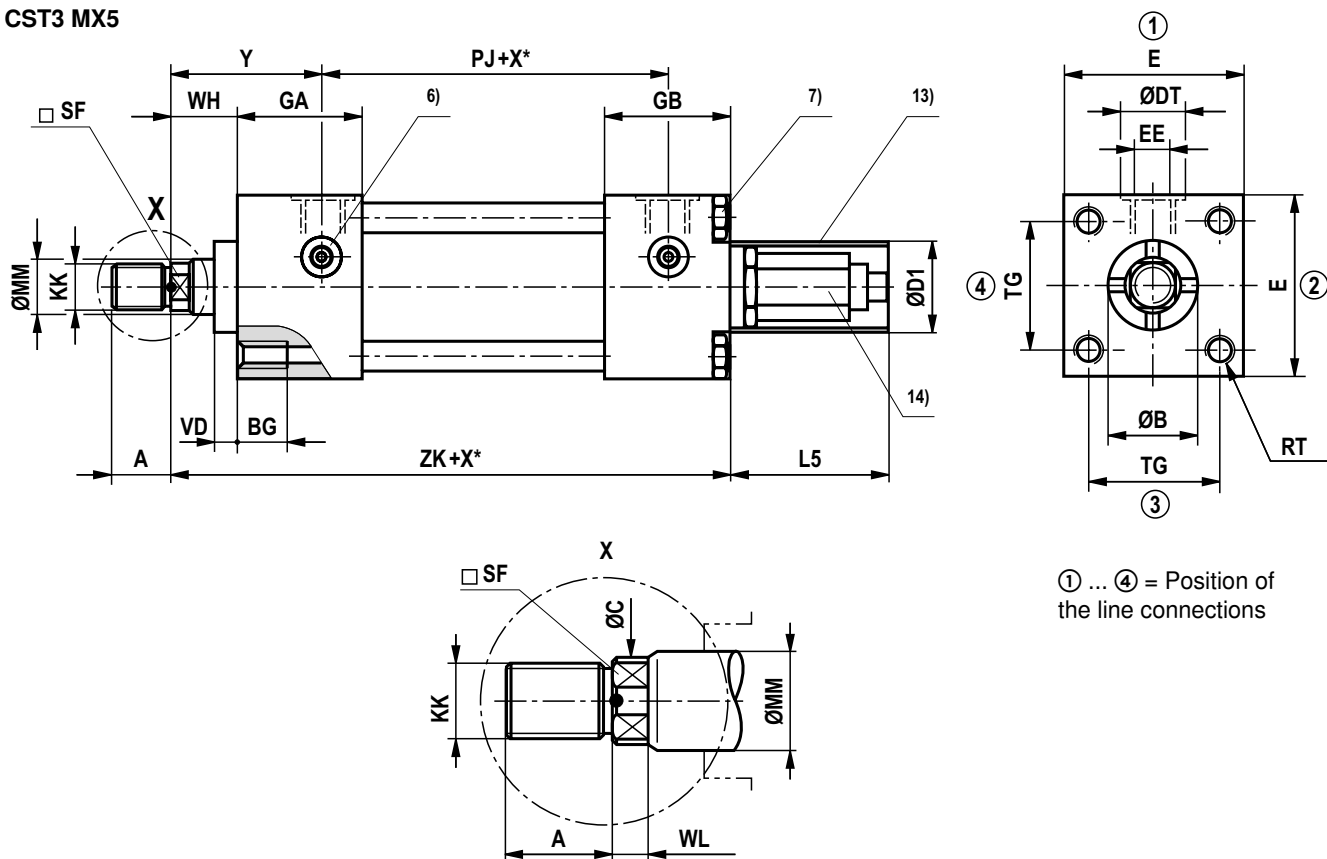

\square AL	\square MM	BG min	PJ ± 1.25	RT 6H	TG js13	VD	ZK ± 1	X* min without subplate	X* min with subplate
40	28	12	73	M8x1.25	41.7	12	195	-	50
50	28 36	18	74	M12x1.75	52.3	9	194	-	50
63	36 45	18	80	M12x1.75	64.3	13	205	-	45
80	45 56	24	93	M16x2	82.7	9	234	-	32
100	56 70	24	101	M16x2	96.9	10	248	-	57
125	70 90	27	117	M22x2.5	125.9	10	265.5	-	35
160	70 110	32	130	M27x3	154.9	7	277	20	20
200	90 140	40	165	M30x3.5	190.2	7	326.5	20	20

Dimensions: Tapped hole at head CST3; MX5 (dimensions in mm)

ØAL	ØMM	DIN / ISO ¹⁾					ISO ²⁾					ØB f9
		KK ¹⁾	A ¹⁾ max	ØC	SF	WL	KK ²⁾	A ²⁾ max	ØC	SF	WL	
40	28	M14x1.5	18	26	22	7	M20x1.5	28	26	22	7	42
50	28	M16x1.5	22	26	22	7	M20x1.5	28	26	22	7	42
	36	M16x1.5	22	34	30	8	M27x2	36	34	30	8	50
63	36	M20x1.5	28	34	30	8	M27x2	36	34	30	8	50
	45	M20x1.5	28	43	36	10	M33x2	45	43	36	10	60
80	45	M27x2	36	43	36	10	M33x2	45	43	36	10	60
	56	M27x2	36	54	46	10	M42x2	56	54	46	10	72
100	56	M33x2	45	54	46	10	M42x2	56	54	46	10	72
	70	M33x2	45	68	60	15	M48x2	63	68	60	15	88
125	70	–	–	–	–	–	M48x2	63	68	60	15	88
	90	M42x2	56	86	75	15	M64x3	85	86	75	15	108
160	70	M48x2	63	68	60	15	–	–	–	–	–	88
	110	M48x2	63	106	92	18	M80x3	95	106	92	18	133
200	90	M64x3	85	86	75	15	–	–	–	–	–	108
	140	M64x3	85	136	125	18	M100x3	112	136	125	18	163

ØAL	L5	ØD1 max	E	EE	DT	GA	GB	WH ± 2	Y ± 2
40	–	–	63 ± 1.5	G 3/8	28	52.5	75.5	25	62
50	–	–	75 ± 1.5	G 1/2	34	57.5	68.5	25	67
63	82	96	90 ± 1.5	G 1/2	34	57.5	72.5	32	71
80	82	96	115 ± 1.5	G 3/4	42	67	85	31	77
100	82	96	130 ± 2	G 3/4	42	70	88	35	82
125	82	96	165 ± 2	G 1	47	76	87.5	35	86
160	82	96	205 ± 2	G 1	47	83	90	32	86
200	82	96	245 ± 2	G 1 1/4	58	107.5	105	32	98

ØAL = Piston Ø

ØMM = Piston rod Ø

X* = Stroke length

X*min = min. stroke length

X*max = max. stroke length

1) Thread for piston rod ends "F" and "H"

2) Thread for piston rod ends "D" and "K"

6) For the position of the line connections and the bleeding see page 41

7) Tightening torque see page 63

13) With piston Ø 40 – 50 mm without protective pipe

14) Installation space for position measurement system at least 200 mm

Leakage oil connection / Enlarged line connection (dimensions in mm)

Leakage oil connection

If technical high-quality seals are used, use of a leakage oil connection is generally not necessary. A drag oil collection connection is only recommended in special cases such as an extension velocity of more than 2 times the retraction velocity with larger strokes, permanent pressurization and the like. In case the extension velocities are more than 5 times the retraction velocity, please contact us.

ME6, MP5, MS2, MT4, Ø 25, 32, 40

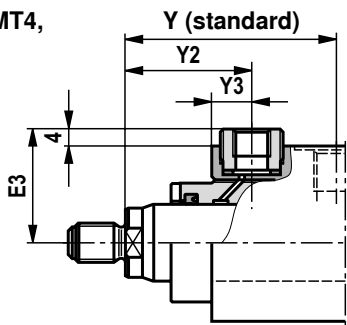

ØAL	ØMM	MS2, MT4 ME6, MP5				ME5	
		e	Y2	Y3	E3	e	Y2
25		0	25.5	10.5	29.5	17	35
32		0	35.5	10.5	32	18	45
40		0	36	11	36	22	47
50		14.5	39	-	-	34	52
63		16	45.5	-	-	43	59
80		16	48	-	-	27	62
100	45	16	52	-	-	30	68
100	70	16	55	-	-	30	68
125	56	18	55.5	-	-	45	68
125	90	18	55.5	-	-	45	68
160	70	24	54.5	-	-	45	68
160	110	24	54.5	-	-	47	68
200	90	24	59.5	-	-	45	72
200	140	24	59.5	-	-	60	72

ME5, ME6, MP5, MS2, MT4, Ø 50 to Ø 200

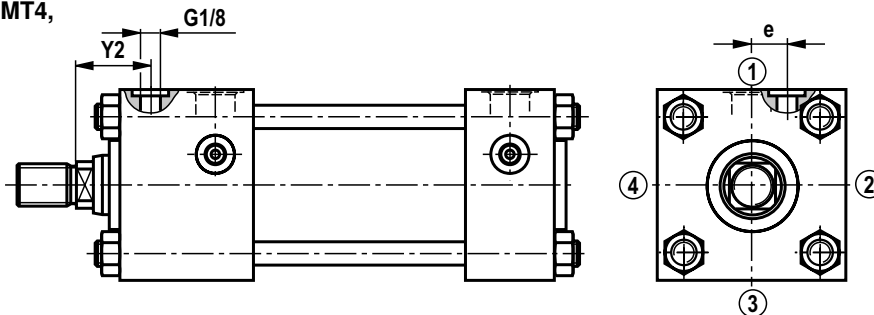

Enlarged line connection

The oil ports of this series are generously dimensioned according to the standard; with high velocity, the pressure drop Δp can be reduced by using larger oil ports; sometimes, it is, however, no longer possible to comply with the standard dimensions, see table.

Cannot be realized for the types of mounting ME 5 / 6 with connection position 2 or 4.

ØAL	EE	H1	Y ±2	PJ ±1.25	SW	Øa
25	G3/8	20	50	53	27	9
32	G3/8	20	60	56	27	9
40	G1/2	23	62	73	32	11
50	G3/4	29	67	74	41	14
63	G3/4	29	71	80	41	14
80	G1	33	77	93	46	18
100	G1	33	82	101	46	18
125	G11/4	39	86	117	60	23
160	G11/4	-	86	130	-	-
200	G11/2	-	98	165	-	-

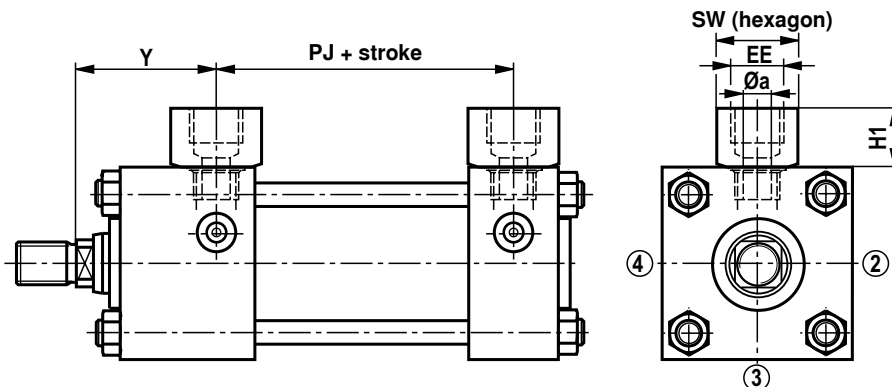

Position of line connections, bleeding, leakage oil, throttle valve

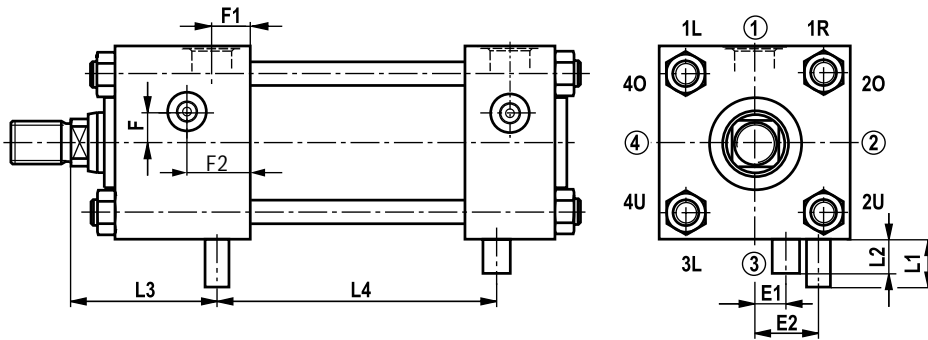

Mounting	Line connection	CDT3 / CST3					CGT3						
		Bleeding Head	Base	Leakage oil Head 1)	Throttle valve Head 1)	Base 1)	Bleeding Head 1	Head 2	Leakage oil Head 1	Head 2	Throttle valve Head 1	Head 2	
MP5, MT4, MP1, MP3, MX1, MX2, MX3, MX5	1	2	2	1	3R	3R	MT4, MX1, MX3	2	4	1	1	3R	3L
	2	3	3	2	4U	4U		3	1	2	2	4U	4O
	3	4	4	3	1L	1L		4	2	3	3	1L	1R
	4	1	1	4	2O	2O		1	3	4	4	2O	2U
ME5	1	2	2	1R	3R	3R	ME5	2	4	1R	1	3R	3L
	2	3R	3	1R	1L	4U		3R	1	1R	2	1L	4O
	3	4	4	3L	1L	1L		4	2	3L	3	1L	1R
	4	1L	1	3L	3R	2O		1L	3	3L	4	3R	2U
MS2	1	2O	2O	1	4O	4O	MS2	2O	4O	1	1	4O	2O
MT1	1	3L	2	-	3R	3R	MT1	3L	4	-	-	3R	3L
	3	1R	4	-	1L	1L		1R	2	-	-	1L	1R
MT2	1	2	3L	1	3R	3R							
	3	4	1R	3	1L	1L							
ME6	1	2	2	1	3R	3R							
	2	3	3	2	4U	1L							
	3	4	4	3	1L	1L							
	4	1	1	4	2O	3R							

- 1) Not possible with CST3
- 2) Protrusion 3 mm.
- 3) Types of mounting ME5 (only base), ME6, MP5, MT4, MP1, MP3, MT2, MX1, MX2, MX3 and MX5.
- 4) Position of line connection

ØAL	F				F1		F2		SW Allen wrench	Throttle valve adjustable on both sides				Dimension	
	Head/base				Position of line connection		Position of bleeding			Protrusion		Center offset		L3	L4
	3)		4)		4)		4)			L1 (head)	L2 (base)	E1 (head)	E2 (base)		
					1/3	2/4	1/3	2/4							
		ME5	MT1	MS2	ME5		ME5								
25	0	0	6	5	11.5	23	23	11.5	5 ²⁾	12	12	6	6	48	57 + stroke
32	0	0	5	5	13	25.5	25.5	13	5 ²⁾	12	12	9	9	57.5	61 + stroke
40	10	10	10	10	15.5	19.5	15.5	15.5	5	5.5	5.5	8	8	61.5	74 + stroke
50	10	10	10	10	15.5	29.5	15.5	15.5	5	3	3	10	10	67	74 + stroke
63	14	14	14	14	18.5	20	18.5	18.5	5	0	0	15	15	72	78 + stroke
80	10	10	10	10	21	21	21	21	6	0	0	14	14	81	85 + stroke
100	24/12	24	12	12	23	23	23	23	6	0	0	13	13	86	93 + stroke
125	0	0	12	0	25	25	25	25	6	-	-	22	22	91.5	109 + stroke
160	0	0	0	0	29	29	29	29	6	4	-	30	30	93.5	115 + stroke
200	0	0	0	0	41.5	41.5	31.5	31.5	6	4	-	30	30	114	128 + stroke

Bleeding / threaded coupling (dimensions in mm)

By default, a patented safety bleeding device against unintended screwing out in head and base is delivered for piston $\varnothing \geq 40$ mm.

For piston $\varnothing 25$ and 32 mm, a bleed screw G1/8 is installed in head and base which is **not** secured against screwing out.

The port allows for the installation of a threaded coupling with check valve for pressure measurement or contamination-free bleeding. Threaded coupling with check valve function, i.e. it can also be connected when the system is pressurized.

Connection possibility for threaded coupling

Piston \varnothing (AL) 25 and 32 mm

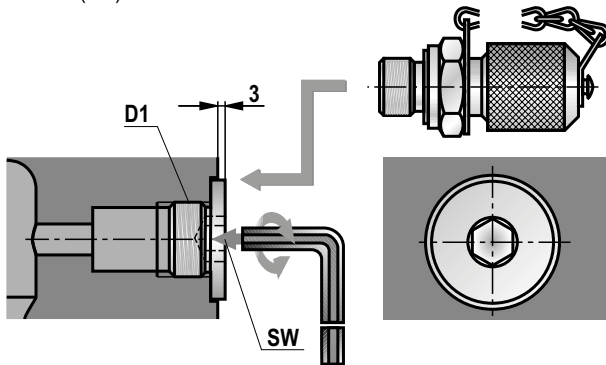

Piston \varnothing (AL) 40 to 200 mm

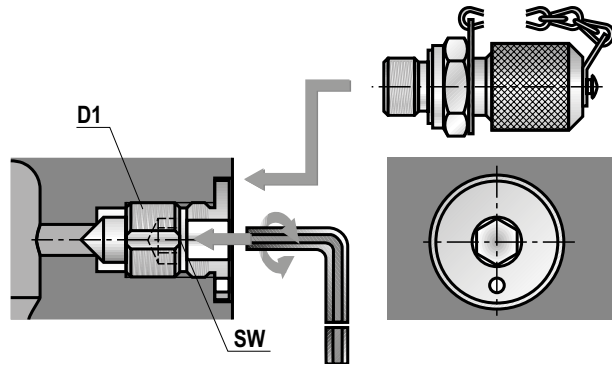

\varnothing AL	Bleed screw			Threaded coupling
	D1	Fuse	SW	D2
25 and 32	G1/8	not secured	5	G1/8
40 and 63	G1/8	secured	5	G1/8
80 to 200	G1/4	secured	6	G1/4

Scope of delivery: Threaded coupling **G1/8**

SCHRAUBKUPPLUNG AB 20-11/K3 G1/8 with seal ring of NBR

Material no. **R900014363**

SCHRAUBKUPPLUNG AB 20-11/K3V G1/8 with seal ring of FKM

Material no. **R900024710**

Scope of delivery: Threaded coupling **G1/4**

SCHRAUBKUPPLUNG AB 20-11/K1 G1/4 with seal ring of NBR

Material no. **R900009090**

SCHRAUBKUPPLUNG AB 20-11/K1V G1/4 with seal ring of FKM

Material no. **R900001264**

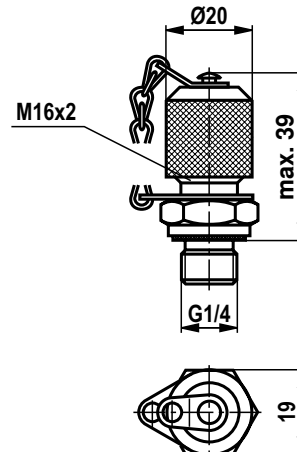

Subplates for valve mounting – Dimensions and porting pattern (dimensions in mm)

MX5
ME5, MS2, MT4

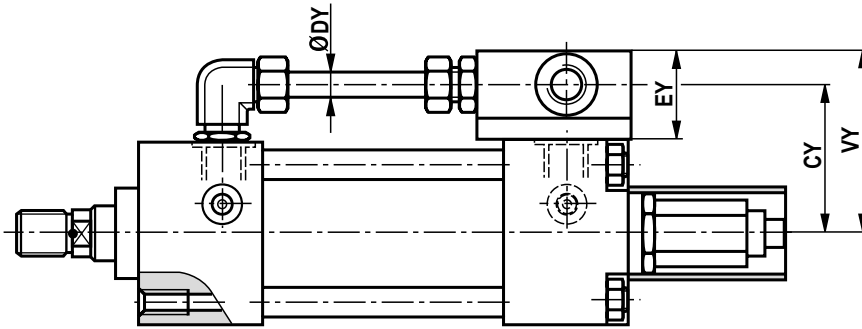

MP5

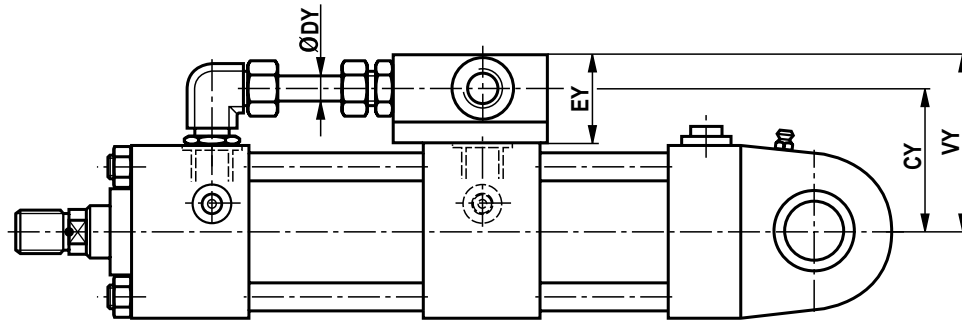

NG6
Porting pattern according to ISO 4401

NG10
Porting pattern according to ISO 4401

NG16
Porting pattern according to ISO 4401

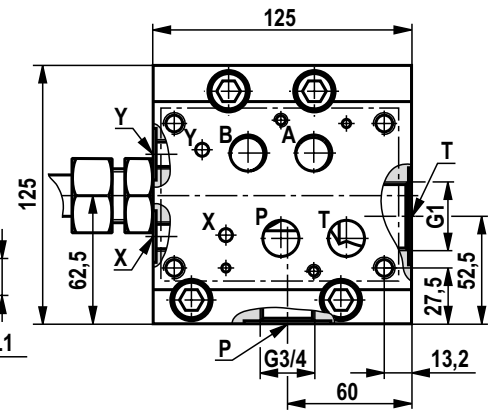
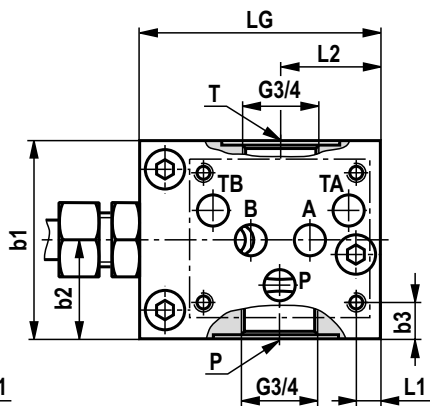
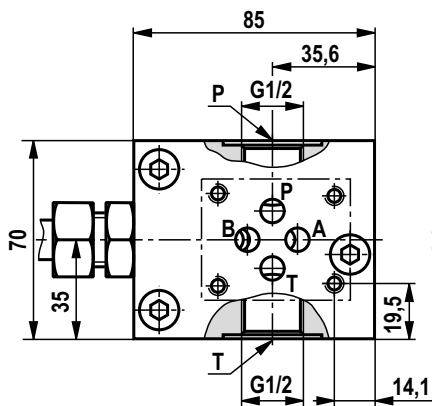

ØAL	NG6				NG10								NG16					
	CY	EY	VY	ØDY	CY	EY	VY	ØDY	LG	L1	L2	b1	b2	b3	CY	EY	VY	ØDY
40	63.2	49.7	81.2	15	63.2	49.7	81.2	15	85	8.5	35.5	70	35	13	-	-	-	-
50	69.2	49.7	87.2	15	69.2	49.7	87.2	15	85	8.5	35.5	70	35	13	-	-	-	-
63	76.7	49.7	94.7	15	76.7	49.7	94.7	15	85	8.5	35.5	70	35	13	-	-	-	-
80	89.2	49.7	107.2	15	89.2	49.7	107.2	15	85	8.5	35.5	70	35	13	-	-	-	-
100	-	-	-	-	106.4	64.7	129.7	20	110	27	52	125	62.5	39.5	104	79.7	144.7	20
125	-	-	-	-	123.9	64.7	147.2	20	110	27	52	125	62.5	39.5	121.5	79.7	162.2	20
160	-	-	-	-	143.9	64.7	167.2	20	110	27	52	125	62.5	39.5	141.5	79.7	182.2	20
200	-	-	-	-	163.9	64.7	187.2	20	110	27	52	125	62.5	39.5	161.5	79.7	202.2	20

For the weight of the subplates refer to page 44.

Weight: Subplates

ØAL	NG6 in kg	NG10 in kg	NG16 in kg
40	2.3	2.3	–
50	2.3	2.3	–
63	2.3	2.3	–
80	2.3	2.3	–
100	–	7.0	9.8
125	–	7.0	9.8
160	–	7.0	9.8
200	–	7.0	9.8

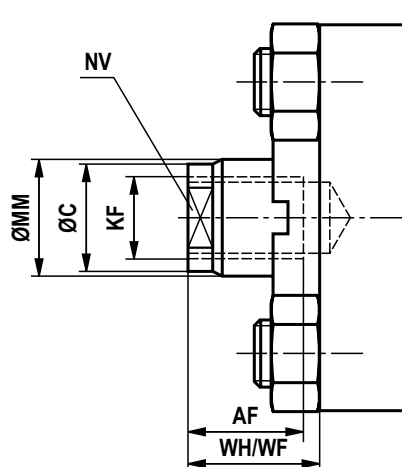
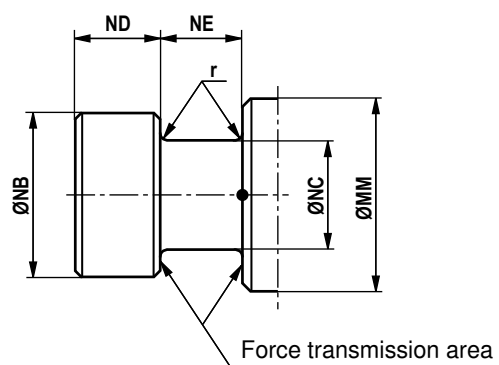
Piston rod ends E and T (dimensions in mm)**Internal thread E****Trunnion T**

ØAL	ØMM	Stroke ²⁾ min	KF	AF	ØC	NV	ØNB h13	ØNC h13	ND / NE h13 / H11	r	p max. ¹⁾ bar
25	18	14	M12x1.25	18	17	15	–	–	–	–	–
32	22	17	M16x1.5	22	21	18	18	11.2	8	0.5	160
40	18	20	M12x1.25	18	17	15	–	–	–	–	–
	28	36	M20x1.5	28	25	22	22.4	14	10	0.5	160
50	22	27	M16x1.5	22	21	18	18	11.2	8	0.5	105
	36	56	M27x2	36	33	30	28	18	12.5	0.8	190
63	28	33	M20x1.5	28	25	22	22.4	14	10	0.5	95
	45	61	M33x2	45	42	36	35.5	22.4	16	0.8	160
80	36	47	M27x2	36	33	30	28	18	12.5	0.8	105
	56	64	M42x2	56	53	46	45	28	20	1.2	160
100	45	0	M33x2	45	42	36	35.5	22.4	16	0.8	90
	70	0	M48x2	63	67	60	56	35.5	25	1.2	160
125	56	0	M42x2	56	53	46	45	28	20	1.2	100
	90	30	M64x3	85	86	75	78	45	30	1.5	160
160	70	5	M48x2	63	67	60	56	35.5	25	1.5	90
	110	45	M80x3	95	106	92	106	65	35	1.5	160
200	90	35	M64x3	85	86	75	78	45	30	1.5	90
	140	67	M100x3	112	136	125	136	70	45	1.5	160

1) with pulling load

2) = minimum stroke length with piston rod end "E" and only with CGT3

Position measurement system

The position measurement system that is pressure-resistant up to 500 bar works in a contactless and absolute manner. The basis of this position measurement system is the magnetostrictive effect. Here, the coincidence of two magnetic fields triggers a torsional impulse.

This impulse runs on the wave guide inside the scale from the measuring point to the sensor head. The running time is constant and almost independent of temperature. It is proportional to the solenoid position and thus a measure for the actual position value and is converted within the sensor into a direct analog or digital output.

Technical data

(For applications outside these parameters, please consult us!)

Operating pressure		bar	160
Analog output		V	0 to 10
	Load resistance	k Ω	≥ 5
	Resolution		unlimited
Analog output		mA	4 to 20
	Load resistance	Ω	0 to 500
	Resolution		unlimited
Digital output			SSI 24 bit gray-coded
	Resolution	μm	5
	Direction of measurement		asynchronously forward
Linearity (absolute accuracy)	Analog	% mm	$\leq \pm 0.02\%$ (referred to measurement length) min. ± 0.05
	Digital	% mm	$\leq \pm 0.01\%$ (referred to measurement length) min. ± 0.04
Reproducibility		% mm	± 0.001 (referred to measurement length) min. ± 0.0025
Hysteresis		mm	≤ 0.004
Supply voltage		V DC	24 ($\pm 10\%$ with analog output)
	Current consumption	mA	100
	Residual ripple	% s-s	≤ 1
	Current consumption	V DC mA	24 ($+20\%$ / -15% with digital output) 70
	Residual ripple	% s-s	≤ 1
Protection class	Pipe and flange		IP 67
	Sensor electronics		IP 65
Operating temperature	Sensor electronics	$^{\circ}\text{C}$	-40 to $+75$
Temperature coefficient	Voltage	ppm/ $^{\circ}\text{C}$	70
	Current	ppm/ $^{\circ}\text{C}$	90

Position measurement system

1) For analog output:

6-pole amphenol mating connector

Material no. **R900072231**

(mating connector is **not** included in the scope of delivery, must be ordered separately)



1) For digital output:

7-pole amphenol mating connector

Material no. **R900079551**

(mating connector is **not** included in the scope of delivery, must be ordered separately)



Pin assignment

Position measurement system (analog output)

Connector (view to pin side)

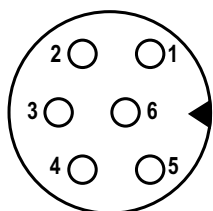

Pin	Cable	Signal / current	Signal / voltage
1	gray	4...20 mA	0 ... 10 V
2	pink	DC ground	DC ground
3	yellow	not used	not used
4	green	DC ground	DC ground
5	brown	+24 V DC (+20 % / -15 %)	+24 V DC (+20 % / -15 %)
6	white	DC ground (0 V)	DC ground (0 V)

Position measurement system (digital output)

Connector (view to pin side)

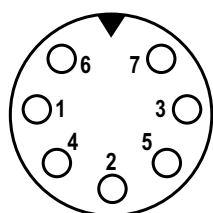

Pin	Cable	Signal / SSI
1	gray	Data (-)
2	pink	Data (+)
3	yellow	Clock (+)
4	green	Clock (-)
5	brown	+24 V DC (+20% / -15%)
6	white	DC ground (0 V)
7	-	not used

Swivel head CGKA - AP 6 (clampable) (dimensions in mm)

ISO 8133

DIN 24555

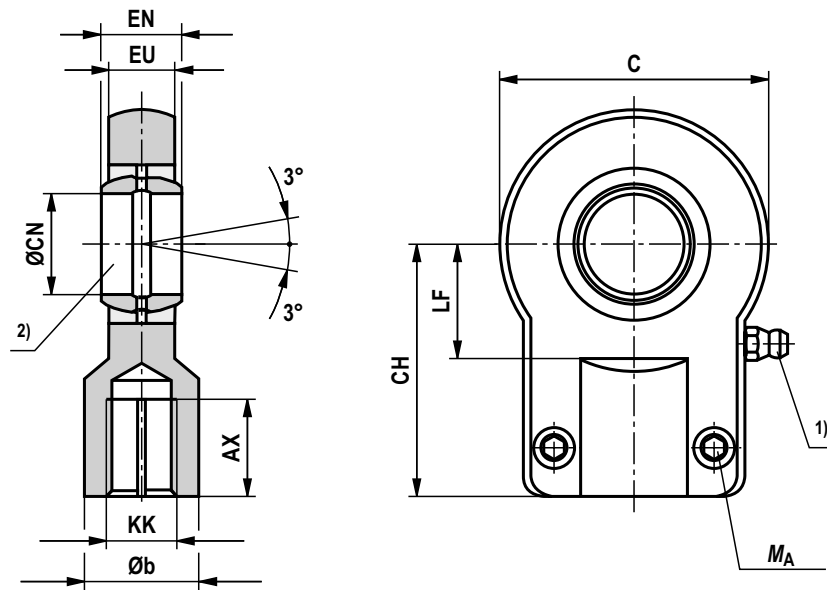

Type	Material no.	KK	AX min	Øb	C max	CH js13	ØCN	EN	EU max	LF min	M_A ⁷⁾ Nm	m ⁸⁾ kg	C_0 ⁹⁾ (head) kN	F_{adm} ¹⁰⁾ kN
CGKA 12 ³⁾	R900327186	M10 x1.25	15	17	40	42	12 -0.008	10 -0.12	8	16	9.5	0.15	17	6.3
CGKA 16 ⁴⁾	R900327192	M12x1.25	17	21	45	48	16 -0.008	14 -0.12	11	20	9.5	0.25	28.5	10.5
CGKA 20 ⁴⁾	R900306874	M14x1.5	19	25	55	58	20 -0.012	16 -0.12	13	25	23	0.43	42.5	15.7
CGKA 25	R900327191	M16x1.5	23	30	65	68	25 -0.012	20 -0.12	17	30	23	0.73	67	24.7
CGKA 30	R900327187	M20x1.5	29	36	80	85	30 -0.012	22 -0.12	19	35	46	1.3	108	39.9
CGKA 40	R900327188	M27x2	37	45	100	105	40 -0.012	28 -0.12	23	45	46	2.3	156	57.6
CGKA 50	R900327368	M33x2	46	55	125	130	50 -0.012	35 -0.12	30	58	80	4.4	245	90.4
CGKA 60	R900327369	M42x2	57	68	160	150	60 -0.012	44 -0.12	38	68	195	8.4	380	140.2
CGKA 80	R900327370	M48x2	64	90	205	185	80 -0.015	55 -0.15	47	82 ⁶⁾	385	15.6	585	215.9
CGKA 100	R900327371	M64x3	86	110	240	240	100 -0.02	70 -0.2	57	116	660	28	865	319.2
CGKD 100 ⁵⁾	R900322030	M80x3	96	110	210	210	100 H7	100 h12	84	98	385	28	1060	391.1
CGKD 125 ⁵⁾	R900322026	M100x3	113	135	262	260	125 H7	125 h12	102	120	385	43	1200	442.8

Note:

Geometry and dimensions may differ depending on the manufacturer.

In case of combination with other mounting elements, the usability must be checked.

1) Lubricating nipple, cone head form A according to DIN 71412

2) Bolt Ø h6 required

3) Cannot be re-lubricated

4) Can be re-lubricated via lubricating hole

5) Swivel head according to ISO 8132, bolt Ø m6 required

6) Dimensions may differ from the standard depending on the manufacturer

7) M_A = Tightening torque

The swivel head must always be screwed against the piston rod shoulder. Afterwards, the clamping screws must be tightened with the specified tightening torque.

8) m = Weight of swivel head in kg

9) C_0 = Static load rating of the swivel head

10) F_{adm} = Maximum admissible load on the swivel head during oscillatory or alternating loads

Clevis bracket CLCB - AB 5 (clampable) (dimensions in mm)

ISO 8133

DIN 24556

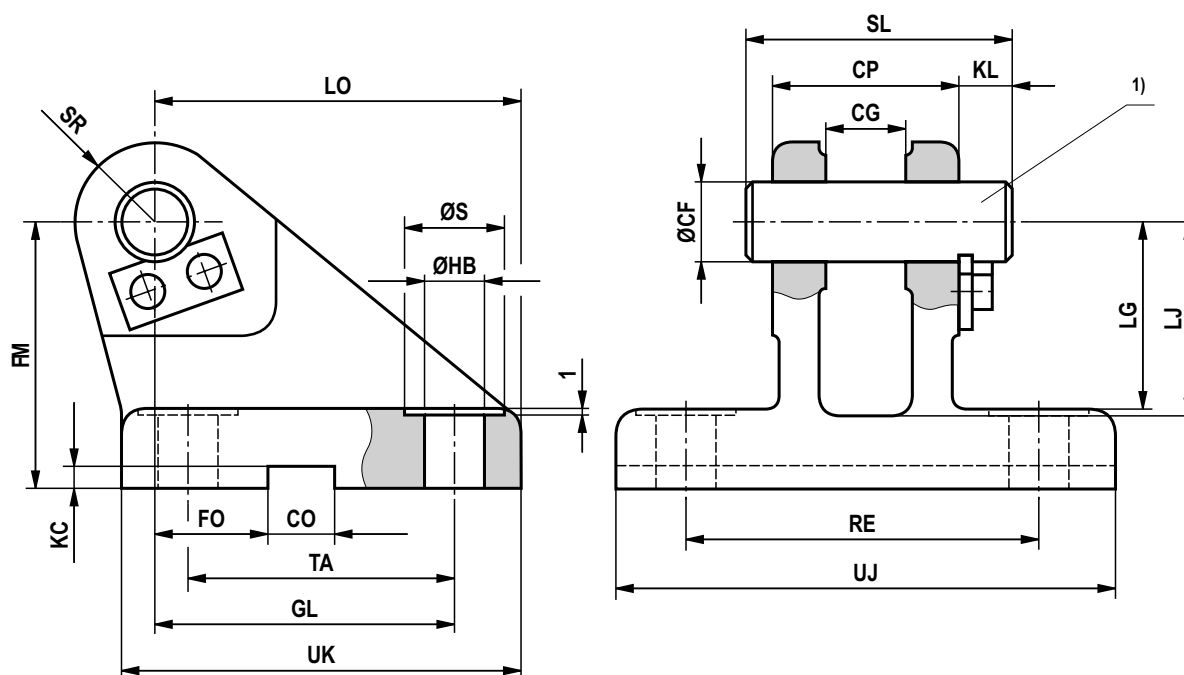

Type	Material no.	Nominal force kN	ØCF K7 ¹⁾	CP h14	CG + 0.1 + 0.3	CO N9	FO js14	FM js11	GL js13	ØHB	ØS
CLCB 12	R900326960	8	12	30	10	10	16	40	46	9	15
CLCB 16	R900327372	12.5	16	40	14	16	18	50	61	11	18
CLCB 20	R900327373	20	20	50	16	16	20	55	64	14 ³⁾	20
CLCB 25	R900326961	32	25	60	20	25	22	65	78	16 ³⁾	24
CLCB 30	R900327374	50	30	70	22	25	24	85	97	18 ³⁾	26
CLCB 40	R900327375	80	40	80	28	36	24	100	123	22	33
CLCB 50	R900327376	125	50	100	35	36	35	125	155	30	48
CLCB 60	R900327377	200	60	120	44	50	35	150	187	39	60
CLCB 80	R900327378	320	80	160	55	50	35	190	255	45	80
CLCB 100	R900327379	500	100	200	70	63	35	210	285	48	80

Clevis bracket CLCB - AB 5 (clampable) (dimensions in mm)

Type	KC + 0.3 0	KL	LG	LJ	LO	RE js13	SL	SR max.	TA js13	UJ	UK	<i>m</i> ²⁾ kg
CLCB 12	3.3	8	28	29	56	55	40	12	40	75	60	0.6
CLCB 16	4.3	8	37	38	74	70	50	16	55	95	80	1.3
CLCB 20	4.3	10	39	40	80	85	62	20	58	120	90	2.1
CLCB 25	5.4	10	48	49	98	100	72	25	70	140	110	3.2
CLCB 30	5.4	13	62	63	120	115	85	30	90	160	135	6.5
CLCB 40	8.4	16	72	73	148	135	100	40	120	190	170	12.0
CLCB 50	8.4	19	90	92	190	170	122	50	145	240	215	23.0
CLCB 60	11.4	20	108	110	225	200	145	60	185	270	260	37.0
CLCB 80	11.4	26	140	142	295	240	190	80	260	320	340	79.0
CLCB 100	12.4	30	150	152	335	300	235	100	300	400	400	140.0

Note:

Geometry and dimensions may differ depending on the manufacturer.

In case of combination with other mounting elements, the usability must be checked.

¹⁾ Bolt \varnothing h6 required, suitable for swivel head CGKA... (bolt and bolt lock are included in the scope of delivery)

²⁾ *m* = Weight of clevis bracket in kg

³⁾ Dimensions may differ from the standard depending on the manufacturer

Trunnion bearing block CLTA - AT 4 (dimensions in mm)

CLTA 12-20

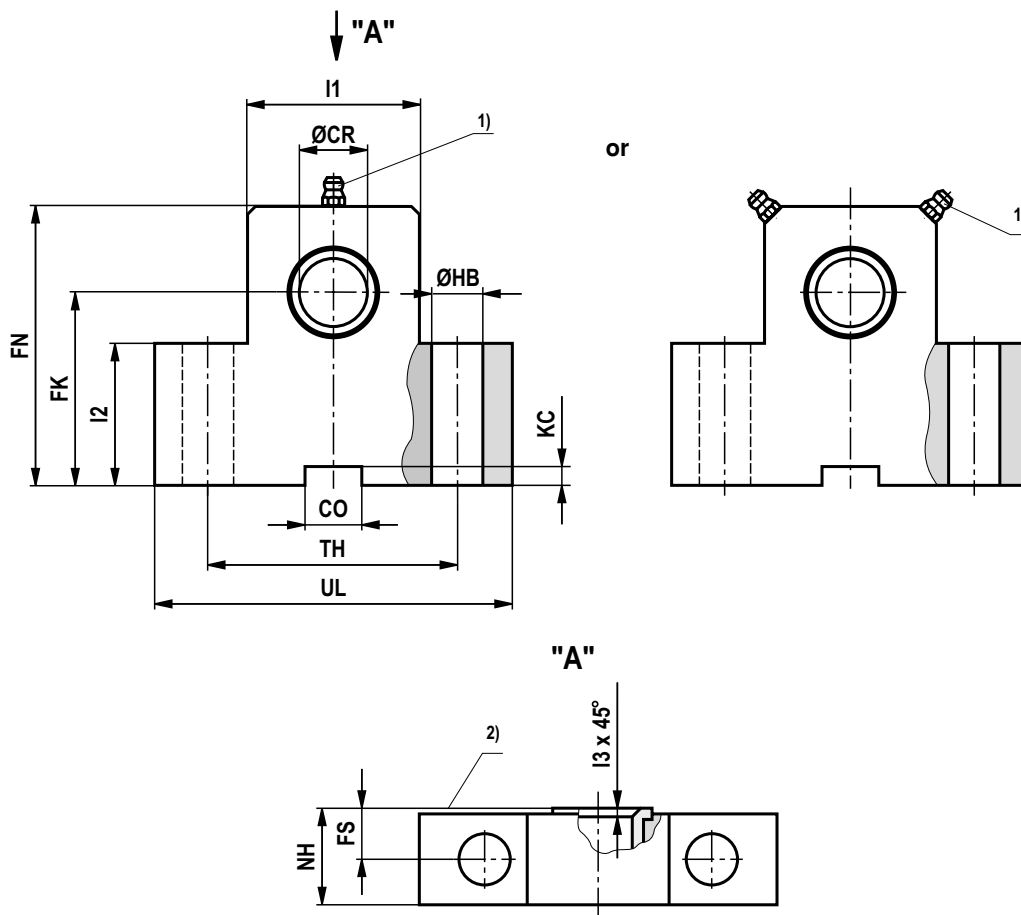

ØAL	Type	Material no.	Nominal force kN ⁴⁾	ØCR H7	CO N9	FK js12	FN max	FS js14	ØHB H13	KC +0.3 0	NH max	TH js14	UL max	I1	I2	I3	m ⁵⁾ kg
25	CLTA 12	R901071355	8	12	10	38	55	8	9	3.3	17 ³⁾	40	63	25	25	1	0.5
32	CLTA 16	R901071364	12.5	16	16	45	65	10	11	4.3	21	50	80	30	30	1	0.9
40	CLTA 20	R901071365	20	20	16	55	80	10	11	4.3	21	60	90	40	38	1.5	1.35

Note:

Geometry and dimensions may differ depending on the manufacturer.

In case of combination with other mounting elements, the usability must be checked.

ØAL = Piston Ø

1) Lubricating nipple, cone form A according to DIN 71412

2) Inside

3) Dimensions may differ depending on the manufacturer

4) Nominal force applies to applications in pairs

5) m = Weight per pair in kg, brackets are delivered in pairs

Trunnion bearing block CLTA - AT 4 (dimensions in mm)

CLTA 25-100

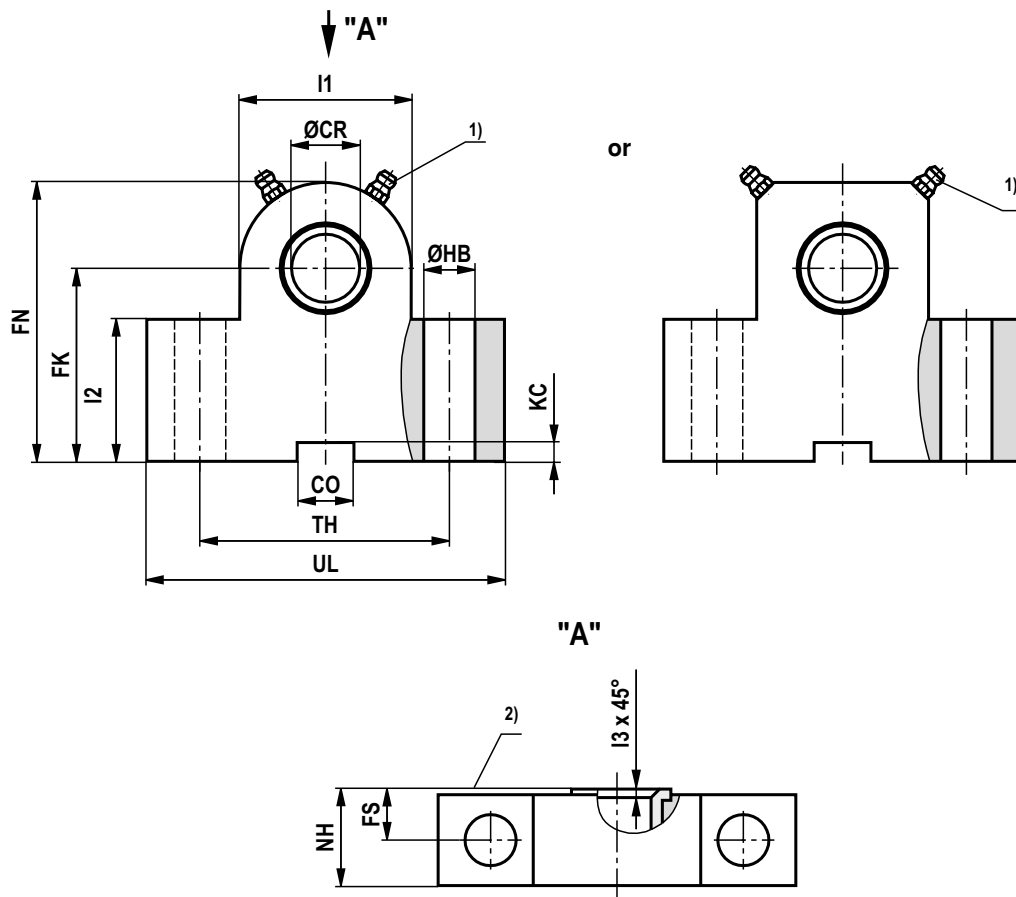

ØAL	Type	Material no.	Nominal force kN ⁴⁾	ØCR H7	CO N9	FK js12	FN max	FS js14	ØHB H13	KC +0.3 0	NH max	TH js14	UL max	I1	I2	I3	m ⁵⁾ kg
50	CLTA 25	R901071368	32	25	25	65	90	12	14 ³⁾	5.4	26	80	110	56	45	1.5	2.4
63	CLTA 32	R901071377	50	32	25	75	110	15	18 ³⁾	5.4	33	110	150	70	52	2	5.0
80	CLTA 40	R901071380	80	40	36	95	140	16	22	8.4	41	125	170	88	60	2.5	8.5
100	CLTA 50	R901071385	125	50	36	105	150	20	26	8.4	51	160	210	90	72	2.5	15
125	CLTA 63	R901071395	200	63	50	125	195	25	33	11.4	61	200	265	136	87	3	30
160	CLTA 80	R901071398	320	80	50	150	230	31	39	11.4	81	250	325	160	112	3.5	59
200	CLTA 100	R901071400	500	100	63	200	300	42	52	12.4	101	320	410	200	150	4.5	131

Note:

Geometry and dimensions may differ depending on the manufacturer.

In case of combination with other mounting elements, the usability must be checked.

ØAL = Piston Ø

1) Lubricating nipple, cone form A according to DIN 71412

2) Inside

3) Dimensions may differ depending on the manufacturer

4) Nominal force applies to applications in pairs

5) **m** = Weight per pair in kg, brackets are delivered in pairs

Kinking

For the admissible stroke length with flexibly guided load and a factor of 3.5 for safety against kinking, please refer to the relevant table. For other installation positions of the cylinder, the admissible stroke length must be interpolated. Admissible stroke length for non-guided load on request.

Kinking calculations are carried out according to the following formulas:

1. Calculation according to Euler

$$F = \frac{\pi^2 \cdot E \cdot I}{v \cdot L_K^2} \text{ if } \lambda > \lambda_g$$

2. Calculation according to Tetmajer

$$F = \frac{d^2 \cdot \pi (335 - 0.62 \cdot \lambda)}{4 \cdot v} \text{ if } \lambda \leq \lambda_g$$

Influence of the type of mounting on the kinking length:

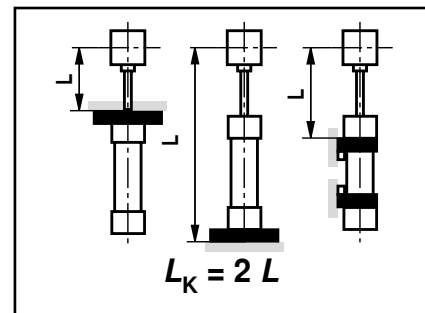
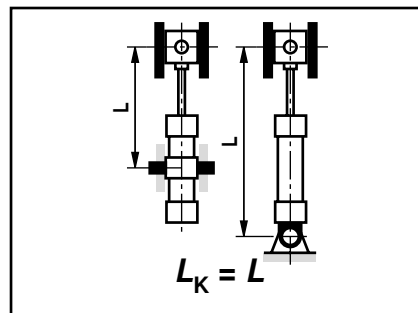
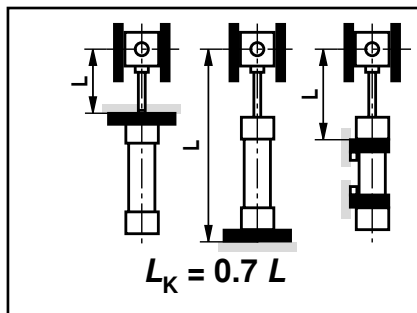

Explanation:

E = Module of elasticity in N/mm²
= 2.1 x 10⁵ for steel

I = Geometrical moment of inertia in mm⁴

for circular cross-section $= \frac{d^4 \cdot \pi}{64} = 0.0491 \cdot d^4$

v = 3.5 (safety factor)

L_K = Free kinking length in mm (depending on the type of mounting see sketches A, B, C)

d = Piston rod Ø in mm

λ = Slenderness ratio

$$= \frac{4 \cdot L_K}{d} \quad \lambda_g = \pi \sqrt{\frac{E}{0.8 \cdot R_e}}$$

R_e = yield strength of the piston rod material

Admissible stroke length (dimensions in mm)

Type of mounting MP1, MP3, MP5

ØAL	ØMM	Admissible stroke length with												Installation position
		70 bar			100 bar			160 bar			210 bar			
		0 °	45 °	90 °	0 °	45 °	90 °	0 °	45 °	90 °	0 °	45 °	90 °	
25	12	115	120	125	85	85	90	50	50	55	180	180	185	
	18	315	330	375	270	275	300	205	210	220				
32	14	115	120	125	85	85	90	50	50	55	210	210	215	
	22	370	385	440	315	325	350	240	245	255				
40	18	160	165	175	120	125	130	75	75	80	130	130	135	
	22	310	320	350	260	265	290	195	200	205				
50	28	465	485	580	400	415	465	315	320	340	280	285	290	
	36	620	650	790	545	565	640	435	445	475				
63	22	205	210	220	155	160	165	100	100	105	190	195	195	
	28	420	430	475	355	360	380	270	275	280				
80	36	620	650	790	545	565	640	435	445	475	395	400	410	
	45	770	810	995	680	710	805	555	565	605				
100	28	280	285	305	220	225	230	150	150	155	280	280	285	
	36	560	580	645	480	490	520	375	380	390				
125	45	770	810	995	680	710	805	555	565	605	500	510	530	
	56	945	995	1225	840	870	995	685	670	745				
160	36	380	390	415	305	310	320	210	215	220	350	355	360	
	45	695	715	800	600	610	650	470	475	490				
200	56	945	995	1225	840	870	995	685	670	745	615	625	655	
	70	1150	1210	1550	1030	1075	1260	855	875	955				
200	56	595	615	685	490	500	535	360	365	375	570	575	595	
	70	1065	1105	1290	940	965	1060	765	775	810				
200	90	1445	1535	2110	1315	1380	1690	1115	1150	1285	1035	1055	1130	
	140	2120	2255	2700	1955	2060	2625	1690	1755	2010				

1) Adm. stroke length

Admissible stroke length (dimensions in mm)

Type of mounting MS2

ØAL	ØMM	Admissible stroke length with												Installation position
		70 bar			100 bar			160 bar			210 bar			
		0 °	45 °	90 °	0 °	45 °	90 °	0 °	45 °	90 °	0 °	45 °	90 °	
25	12	500	510	530	420	425	435	325	325	330				
	18	600	600	600	600	600	600	600	600	600	600	600	600	
32	14	525	535	555	435	440	450	335	335	340				
	22	800	800	800	800	800	800	800	800	800	780	790	800	
40	18	700	715	750	590	595	610	455	460	465				
	22	975	1000	1000	855	875	940	690	700	720	610	610	620	
50	28	1000	1000	1000	1000	1000	1000	1000	1000	1000	1000	1000	1000	
	36	1200	1200	1200	1200	1200	1200	1200	1200	1200	1200	1200	1200	
63	28	1060	1086	1160	900	915	950	705	710	720				
	36	1400	1400	1400	1400	1400	1400	1185	1200	1255	1045	1055	1080	
80	45	1400	1400	1400	1400	1400	1400	1400	1400	1400	1400	1400	1400	
	56	1700	1700	1700	1700	1700	1700	1460	1480	1555	1295	1305	1340	
100	70	2000	2000	2000	2000	2000	2000	1800	1835	1950	1595	1615	1670	
	80	2000	2000	2000	2000	2000	2000	2000	2000	2000	2000	2000	2000	
125	56	2075	2140	2300	1810	1845	1970	1455	1470	1515				
	70	2300	2300	2300	2300	2300	2300	2240	2290	2300	2010	2035	2120	
160	90	2300	2300	2300	2300	2300	2300	2300	2300	2300	2300	2300	2300	
	110	2515	2595	2600	2200	2245	2415	1780	1800	1855	2600	2600	2600	
200	140	2700	2700	2700	2700	2700	2700	2700	2700	2700	2700	2700	2700	
	140	2700	2700	2700	2700	2700	2700	2700	2700	2700	2700	2700	2700	

Type of mounting MT4 (Trunnion position in cylinder center)

ØAL	ØMM	Admissible stroke length with												Installation position
		70 bar			100 bar			160 bar			210 bar			
		0 °	45 °	90 °	0 °	45 °	90 °	0 °	45 °	90 °	0 °	45 °	90 °	
25	12	190	190	200	150	150	155	105	105	105				
	18	455	470	535	395	405	435	310	315	325	275	280	285	
32	14	195	200	205	150	155	155	105	105	105				
	22	535	555	625	460	470	510	365	365	380	320	325	330	
40	18	265	270	290	215	215	225	150	155	155				
	22	430	445	480	360	370	385	275	280	285	230	230	235	
50	28	670	700	825	590	605	670	475	480	505	430	435	445	
	36	330	335	355	265	270	280	190	195	195				
63	28	570	590	645	485	495	520	375	380	390	315	315	320	
	36	885	925	1115	785	810	910	640	655	690	580	590	610	
80	28	435	445	470	355	360	375	265	265	270				
	36	755	780	865	650	660	700	510	575	530	430	430	440	
100	45	1095	1145	1390	975	1010	1140	800	815	870	725	735	765	
	56	585	595	630	480	485	505	340	360	365				
125	70	890	920	1025	760	775	830	590	595	615	535	540	550	
	80	1340	1400	1700	1195	1240	1405	1000	1010	1075	885	900	940	
160	90	725	745	805	605	615	645	415	440	475				
	110	1090	1130	1295	940	965	1045	740	750	782	675	680	695	
200	140	1615	1700	2000	1460	1515	1770	1225	1255	1355	1115	1130	1185	
	140	900	925	1015	760	775	820	485	520	605				
125	70	1340	1395	1640	1170	1205	1330	940	955	1000	855	865	890	
	90	2035	2150	2300	1860	1945	2300	1590	1635	1815	1480	1510	1605	
160	110	1100	1300	1255	935	955	1015	730	735	760				
	140	2410	2550	2600	2210	2315	2600	1905	1960	2180	1720	1755	1875	
200	140	1420	1470	1680	1225	1255	1360	770	830	1020				
	140	2700	2700	2700	2700	2700	2700	2415	2495	2700	2195	2250	2240	

Admissible stroke length (dimensions in mm)

Type of mounting ME5, MX3, MX5

ØAL	ØMM	Admissible stroke length with												Installation position
		70 bar			100 bar			160 bar			210 bar			
		0 °	45 °	90 °	0 °	45 °	90 °	0 °	45 °	90 °	0 °	45 °	90 °	
25	12	510	520	540	430	435	445	335	335	340				
	18	600	600	600	600	600	600	600	600	600	600	600	600	
32	14	535	545	565	445	450	460	345	345	350				
	22	800	800	800	800	800	800	800	800	800	790	800	800	
40	18	710	725	755	600	605	620	465	470	475				
	22	990	1000	1000	870	890	955	705	715	735	620	625	635	
50	28	1000	1000	1000	1000	1000	1000	1000	1000	1000	1000	1000	1000	
	36	1200	1200	1200	1200	1200	1200	1200	1200	1200	1200	1200	1200	
63	28	1080	1100	1170	920	930	965	720	725	740				
	36	1400	1400	1400	1400	1400	1400	1205	1225	1280	1065	1075	1100	
80	45	1400	1400	1400	1400	1400	1400	1400	1400	1400	1400	1400	1400	
	56	1390	1425	1545	1195	1215	1270	950	955	975				
100	45	1700	1700	1700	1700	1700	1700	1485	1510	1580	1310	1325	1360	
	70	2000	2000	2000	2000	2000	2000	2000	2000	2000	2000	2000	2000	
125	56	1700	1700	1700	1700	1700	1700	1700	1700	1700	1700	1700	1700	
	90	2100	2165	2300	1830	1865	1990	1200	1280	1540				
160	70	2300	2300	2300	2300	2300	2300	2255	2300	2300	2030	2060	2140	
	110	2540	2600	2600	2225	2275	2440	1805	1825	1885				
200	90	2600	2600	2600	2600	2600	2600	2600	2600	2600	2600	2600	2600	
	140	2700	2700	2700	2700	2700	2700	2700	2700	2700	2700	2700	2700	

Type of mounting ME6, MX1, MX2

ØAL	ØMM	Admissible stroke length with												Installation position
		70 bar			100 bar			160 bar			210 bar			
		0 °	45 °	90 °	0 °	45 °	90 °	0 °	45 °	90 °	0 °	45 °	90 °	
25	12	195	200	220	160	160	170	115	115	120				
	18	445	465	585	395	410	475	325	330	360	295	295	310	
32	14	205	210	230	165	170	180	120	120	120				
	22	525	550	685	465	485	560	385	390	420	345	350	365	
40	18	270	280	315	225	230	245	165	165	170				
	22	435	455	520	375	385	420	295	300	310	245	250	255	
50	28	645	680	895	580	605	730	485	500	555	450	460	480	
	36	335	350	390	280	285	305	210	210	220				
63	28	580	600	700	505	515	565	400	405	425	335	340	350	
	36	845	895	1200	770	805	990	655	675	755	605	620	655	
80	28	445	460	520	375	385	415	285	290	300				
	36	760	795	940	670	690	765	540	550	580	465	470	490	
100	45	1045	1105	1400	955	1140	1240	815	845	955	765	780	835	
	56	590	610	690	505	515	555	390	395	410				
125	45	940	980	1160	830	855	950	675	685	720	580	585	610	
	70	1275	1350	1700	1170	1225	1520	1005	1035	1175	930	950	1025	
160	45	725	755	885	630	645	710	495	505	530				
	70	1145	1200	1465	1025	1060	1205	850	865	920	730	740	770	
200	56	885	925	1110	775	800	900	620	635	670				
	90	1380	1450	1835	1245	1290	1500	1040	1065	1155	915	935	980	
200	70	1900	2025	2300	1770	1875	2300	1570	1640	1980	1525	1570	1745	
	110	1080	1130	1370	950	985	1110	770	785	835				
200	140	2250	2395	2600	2105	2225	2600	1870	1950	2360	1780	1835	2045	
	90	1375	1445	1825	1225	1275	1485	1010	1035	1120				

End position cushioning

End position cushioning:

The objective is to reduce the velocity of a moved mass, the center of gravity of which lies on the cylinder axis, to a level at which neither the cylinder nor the machine into which the cylinder is installed is damaged.

For velocities above 20 mm/s, we recommend the use of an end position cushioning feature, which absorbs energy without requiring the use of an additional device.

It must, however, always be checked whether end position cushioning is also required for lower velocities with large masses.

With stroke lengths smaller than the damping lengths, we recommend selecting the cylinder without end position cushioning.

With cylinder strokes within the damping lengths, restrictions with regard to speed / cycle time are possible.

The series CDT3 / CGT3 is equipped with a progressive damping system.

Advantages of this damping system:

- Progressive delay.
- Short damping time.
- Damping length depending on the velocity.
- Due to low damping pressures and no pressure peaks, safety and the life cycle of the cylinder and the machine are increased.
- Insensitive to changes in pressure, temperature and the moved masses.
- Controlled end stop velocity of the piston – more safety and reliability.

- Quick start-up due to special check valve and floating bushing.

Cylinders with end position cushioning can achieve their full damping capacity only over the entire stroke length.

With the adjustable end position cushioning version "E", a throttle valve is additionally provided when compared with version "D". End position cushioning "E" allows for optimization of the cycle times.

The max. damping capacity can only be achieved when the throttle valve is closed.

For special applications with very short stroke times, high velocities or large masses, cylinders with special end position cushioning versions can be offered on request.

When fixed or adjustable stops are used, special measures must be taken!

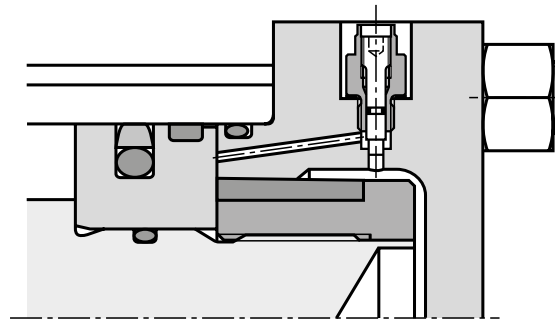

Damping capacity:

When decelerating masses via end position cushioning, the structural-inherent damping capacity must not be exceeded.

To this end, the kinetic energy and potential energy of the moved mass are to be calculated and compared to the admissible values from the diagrams on pages 58 and 59.

Energy determination

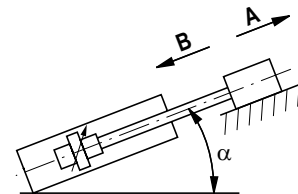
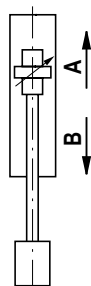
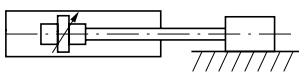

$$E = \frac{1}{2} m \cdot v^2$$

$$\text{Retraction (A): } E = \frac{1}{2} mv^2 - mg \cdot l_a$$

$$\text{Extension (A): } E = \frac{1}{2} mv^2 - mg \cdot l_a \cdot \sin \alpha$$

$$\text{Extension (B): } E = \frac{1}{2} mv^2 + mg \cdot l_a$$

$$\text{Retraction (B): } E = \frac{1}{2} mv^2 + mg \cdot l_a \cdot \sin \alpha$$

E	[Nm] [joule]	Maximum value see pages 56 to 59
m	[kg]	Total moved mass incl. piston and rod

v	[m/s]	Max. velocity
g	[m/s ²]	9.81
l_a	[m]	Damping length, see page 57

End position cushioning

Damping lengths and masses

Cylinder Ø		25		32		40			50			63		
		12	18	14	22	18	22 ¹²⁾	28	22	28 ¹²⁾	36	28	36 ¹²⁾	45
l_a in mm	Head	15	15	16	16	23	23	23	22	22	22	25	25	25
	Base	15	15	16	16	23	23	23	22	22	22	25	25	25
m in kg (kg/100 mm)	Piston	0.15	0.2	0.25	0.4	0.6	0.6	0.7	0.8	1	1.2	1.4	1.7	2.0
	Rod	0.1	0.2	0.12	0.3	0.2	0.3	0.5	0.3	0.5	0.8	0.5	0.8	1.2
v_{max} ¹⁾	(m/s)	0.5	0.5	0.5	0.5	0.5	0.5	0.5	0.5	0.5	0.5	0.4	0.4	0.4

Cylinder Ø		80			100			125			160		200	
		36	45 ¹²⁾	56	45	56 ¹²⁾	70	56	70 ¹²⁾	90	70	110	90	140
l_a in mm	Head	27	27	27	28	28	28	33	33	33	36	36	40	40
	Base	27	27	27	28	28	28	33	33	33	36	36	40	40
m in kg (kg/100 mm)	Piston	2.6	3	3.6	4.7	5.3	6.3	8.0	9.2	11	16	20	30	38
	Rod	0.8	1.2	2.0	1.2	2	3.0	2.0	3	5.0	3.0	7.5	5.0	12
v_{max} ¹⁾	(m/s)	0.4	0.4	0.4	0.3	0.3	0.3	0.3	0.3	0.3	0.25	0.25	0.25	0.25

¹⁾ In case v_{max} is exceeded, please contact us.

¹²⁾ Piston rod Ø not standardized

The diagrams on pages 58 and 59 are based on the preceding table, the maximum velocities specified referring to "M" seals with closed throttle screw.

With slower velocities, the absorbing energy decreases according to the formula.

$$E_U = E_{max} \cdot \frac{v_U}{v_{max}}$$

E_U = Energy absorbing

E_{max} = Energy max. see characteristic curve

v_U = Stroke velocity

v_{max} = Velocity max. for seal design "M"

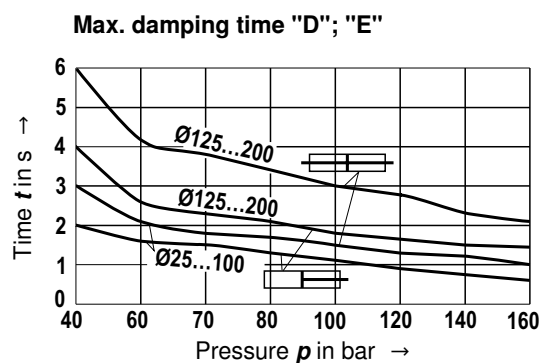

End position cushioning

Damping "D"; "E"

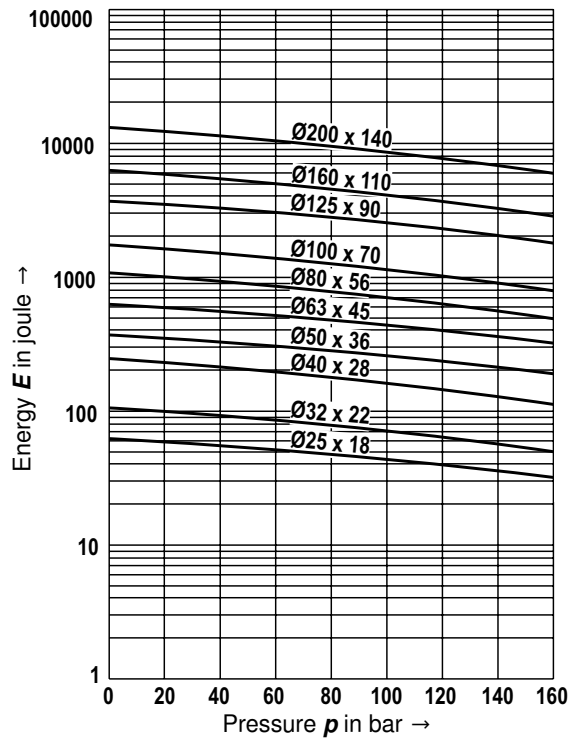
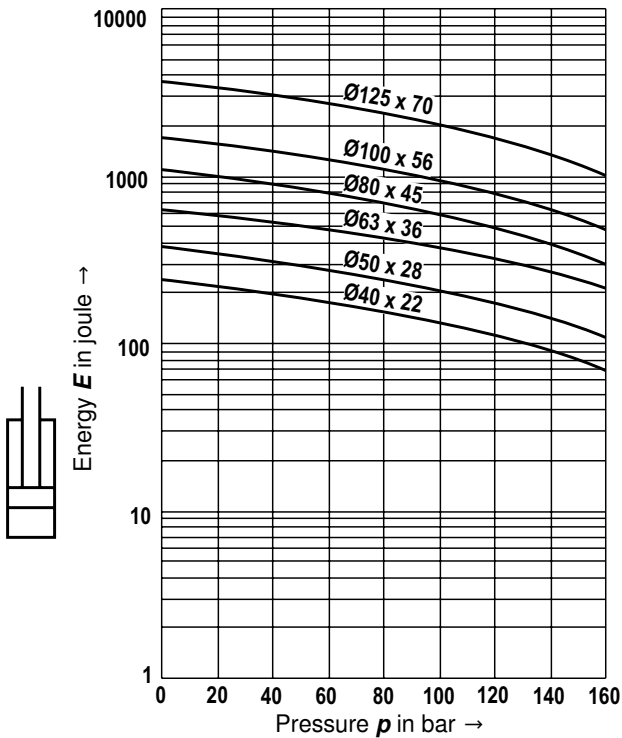
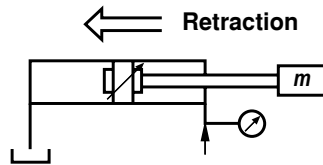
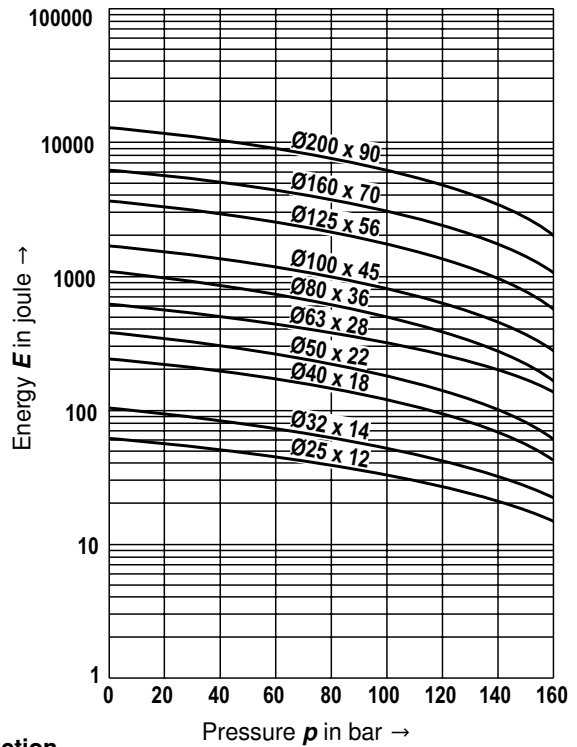
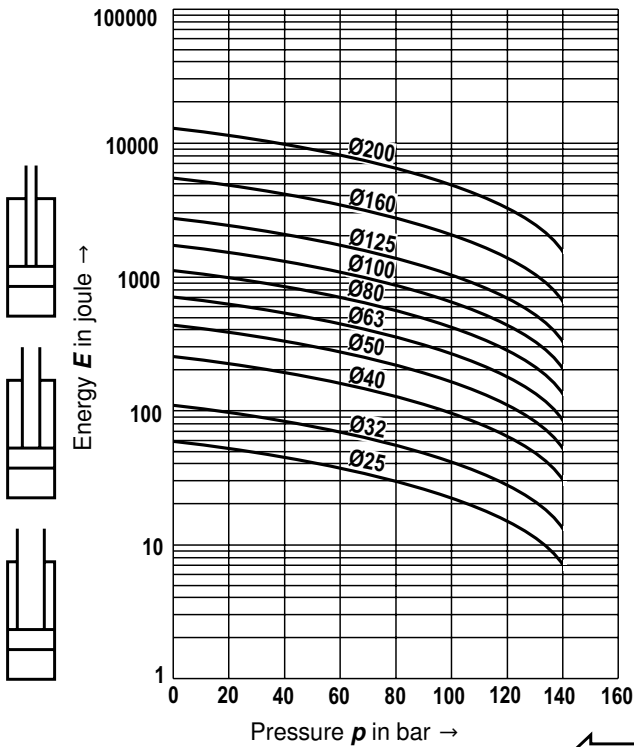
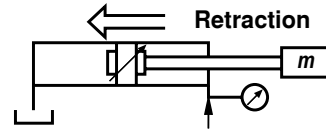
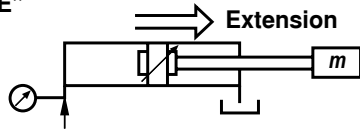

End position cushioning

Damping "D"; "E"

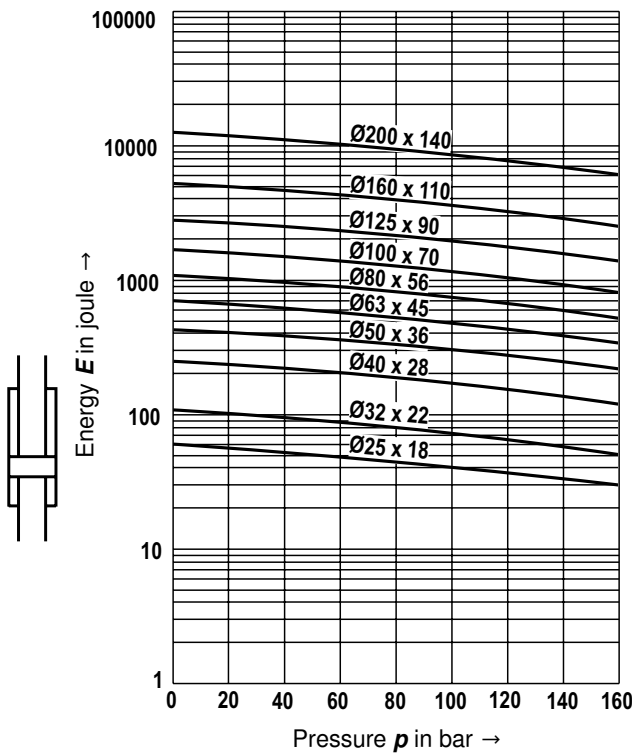
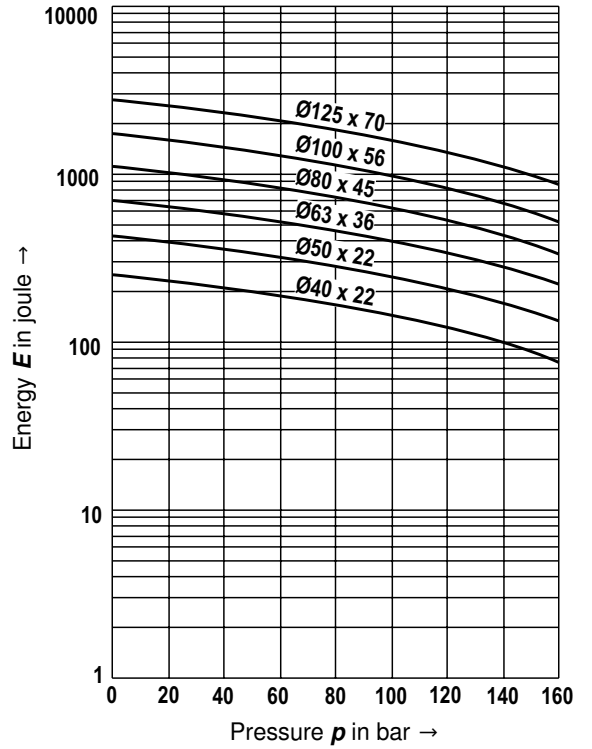
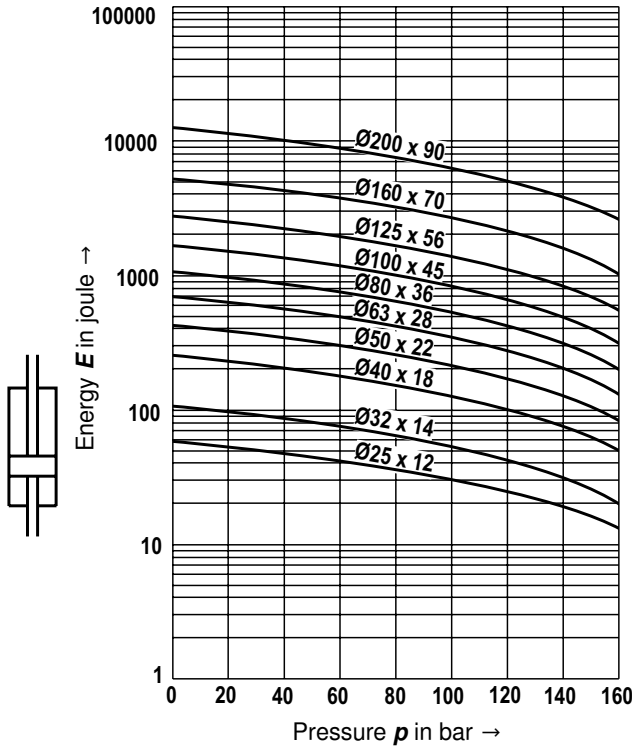
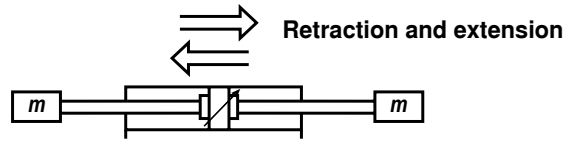

Calculation example

When designing cylinder dimensions, 3 criteria are to be considered:

- Force
- Kinking
- Damping capacity

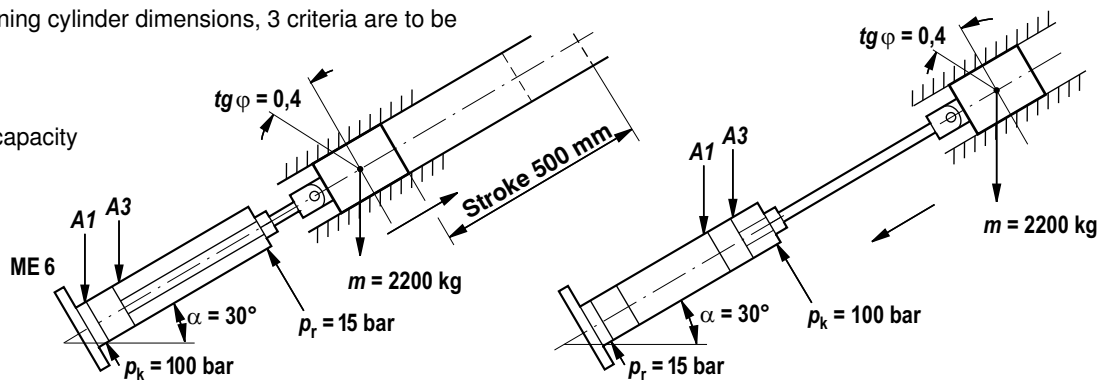

Example:

Stroke time = 2 seconds

Load friction coefficient = $tg \varphi = 0.4$ (estimated)

Available pressure $p_k = 100$ bar

Return flow pressure $p_r = 15$ bar

$A1$ = Piston surface, $A3$ = piston ring surface

φ = Surface ratio $A1 / A3$, see page 5

m = total moved mass, v = velocity

l_a = Damping length, see page 57

To be determined:

Piston and piston rod diameter

Extend piston rod:

Overall efficiency $\eta = \eta1 \cdot \eta2$

$\eta1$ = Cylinder efficiency = 0.9 (estimated)

$\eta2$ = System efficiency

$$\eta2 = \frac{p_k \cdot A1 - p_r \cdot A3}{p_k \cdot A1} = 1 - \frac{p_r}{p_k \cdot \varphi^{1)}} = \frac{15}{100 \cdot 1.25} = 0.88$$

$$\eta = 0.9 \cdot 0.88 = 0.79$$

1) Assuming the smallest " φ "

Force required to move the mass:

F = Frictional force plus potential energy

$$\begin{aligned} &= tg \varphi \cdot m \cdot g \cdot \cos \alpha + m \cdot g \cdot \sin \alpha \\ &= 0.4 \cdot 2200 \cdot 9.81 \cdot 0.866 + 2200 \cdot 9.81 \cdot 0.5 = 18270 \text{ N} \\ &= 18.27 \text{ kN} \end{aligned}$$

This theoretical force 18.27 kN with $\eta = 0.79$ results in a required force = 23.13 kN and thus, a cylinder piston diameter = 63 mm is necessary for $p_k = 100$ bar, see page 5

Retract piston rod:

F = Frictional force minus potential energy

$$\begin{aligned} &= tg \varphi \cdot m \cdot g \cdot \cos \alpha - m \cdot g \cdot \sin \alpha \\ &= 0.4 \cdot 2200 \cdot 9.81 \cdot 0.866 - 2200 \cdot 9.81 \cdot 0.5 \\ &= -3315 \text{ N} = -3.3 \text{ kN} \quad \text{no force problem during retraction} \end{aligned}$$

Test of kinking length:

For $p_k = 100$ bar and cylinder 63 / 28, the table on page 55 results in a maximum admissible stroke = 385 mm:

So the cylinder kinks

There are 2 possibilities:

- Select piston rod diameter 45, max. admissible stroke = 1140 mm, i.e. kinking-proof
- Change the type of mounting, e.g. MS2 with a maximum admissible stroke = 915 mm

Test of the end position cushioning

Average velocity $0.5 / 2 = 0.25$ m/s

Max. velocity $v_u = 0.275$ m/s (estimated correction coefficient = 1.1 due to start-up and braking)

Damping capacity required for piston rod extension =

$$\frac{m \cdot v_u^2}{2} - m \cdot g \cdot l_a \cdot \sin \alpha = \frac{2200 \cdot 0.275^2}{2} - 2200 \cdot 9.81 \cdot 0.025 \cdot 0.5 = -186 \text{ joules}$$

No damping problem for piston rod extension

Damping capacity required for piston rod retraction =

$$\frac{m \cdot v_u^2}{2} + m \cdot g \cdot l_a \cdot \sin \alpha = \frac{2200 \cdot 0.275^2}{2} + 2200 \cdot 9.81 \cdot 0.025 \cdot 0.5 = 353 \text{ joules}$$

Diagram on page 58 results in 445 joules for $p_k = 100$ bar and $v_{max} = 0.4$ m/s, i.e. the cylinder can absorb energy for 0.275 m/s (see page 57):

$$E_u = E_{max} \cdot \frac{v_u}{v_{max}} = 445 \cdot \frac{0.275}{0.4} = 306 \text{ joules}$$

So the cylinder cannot absorb the necessary damping capacity: you have to select the next larger diameter 80 / 56.

Selection criteria for seals

Work and environmental conditions		Seal versions		
		M	T	S
Medium / temperature	Medium HL, HLP / operating temperature medium -20 °C to +80°C	++	++	++
	Medium HFA / operating temperature medium +5 °C to +55°C	+/-	++	+/-
	Medium HFC / operating temperature medium -20 °C to +60°C	-	++	-
	Medium HFD-R / operating temperature medium -15 °C to +80°C	-	-	++
	Medium HFD-U / operating temperature medium -15 °C to +80°C	-	-	++
	Ambient and rod temperature in the area of the piston rod from -20 °C to +80° C ¹⁾	++	+	++ ²⁾
	Extended ambient and rod temperature in the area of the piston rod from +80 °C to +120° C	-	-	++
Function / velocity...	Static holding function more than 10 minutes: Attention! Application- and Temperature-dependent	++	+	+
	Static holding function short-time < 1 minute	++	++	++
	Robust application conditions: Steel works, mining, thin ice	++	-	-
	Zero point control, hardly any amplitude, frequency max. 5 Hz, not longer than 5 minutes	-	++	++
	Cylinder velocity min. 0.001 m/sec stick-slip behavior	++	++	++
	Cylinder velocity from 0.01 m/sec to 0.5 m/sec ³⁾	++	++	++
	Cylinder velocity > 0.5 m/sec to max. 0.8 m/sec ³⁾	-	++	++
	Stroke > 1.0 m	+/-	++	++
	Standstill period (wear)	++	++	++
undissolved air in the oil ⁴⁾	-	+	+	

++ = very good

+ = good

+/- = conditional, depending on the application parameters

- = inappropriate

General technical data in corresponding data sheets will remain valid!

- 1) Moreover, observe the corresponding medium temperature range
- 2) Lower temperature limit -15 °C
- 3) Standard line connections not designed for that velocity
- 4) - Seal is destroyed / + Seal is not directly destroyed, leaks may occur

Generally, a medium temperature of approx. 40°C is recommended. The specified values are to be regarded as guidelines; depending on the case of application, it may be necessary to check the suitability of the seal system.

Seal kits

Seal kit complete

ØAL	ØMM	Material no. for seal design CDT3			Material no. for seal design CGT3		
		M	T	S	M	T	S
25	12	R961008000	R961008026	R961008052	R961008078	R961008104	R961008130
	18	R961008001	R961008027	R961008053	R961008079	R961008105	R961008131
32	14	R961008002	R961008028	R961008054	R961008080	R961008106	R961008132
	22	R961008003	R961008029	R961008055	R961008081	R961008107	R961008133
40	18	R961008004	R961008030	R961008056	R961008082	R961008108	R961008134
	22	R961008005	R961008031	R961008057	R961008083	R961008109	R961008135
	28	R961008006	R961008032	R961008058	R961008084	R961008110	R961008136
50	22	R961008007	R961008033	R961008059	R961008085	R961008111	R961008137
	28	R961008008	R961008034	R961008060	R961008086	R961008112	R961008138
	36	R961008009	R961008035	R961008061	R961008087	R961008113	R961008139
63	28	R961008010	R961008036	R961008062	R961008088	R961008114	R961008140
	36	R961008011	R961008037	R961008063	R961008089	R961008115	R961008141
	45	R961008012	R961008038	R961008064	R961008090	R961008116	R961008142
80	36	R961008013	R961008039	R961008065	R961008091	R961008117	R961008143
	45	R961008014	R961008040	R961008066	R961008092	R961008118	R961008144
	56	R961008015	R961008041	R961008067	R961008093	R961008119	R961008145
100	45	R961008016	R961008042	R961008068	R961008094	R961008120	R961008146
	56	R961008017	R961008043	R961008069	R961008095	R961008121	R961008147
	70	R961008018	R961008044	R961008070	R961008096	R961008122	R961008148
125	56	R961011580	R961011587	R961011595	R961011603	R961011610	R961011617
	70	R961011581	R961011588	R961011596	R961011604	R961011611	R961011618
	90	R961011582	R961011589	R961011597	R961011605	R961011612	R961011619
160	70	R961011583	R961011590	R961011598	R961011606	R961011613	R961011620
	110	R961011584	R961011591	R961011599	R961011607	R961011614	R961011621
200	90	R961011585	R961011592	R961011601	R961011608	R961011615	R961011622
	140	R961011586	R961011593	R961011602	R961011609	R961011616	R961011623

Seal kit CST3 only for cylinder ¹⁾

ØAL	ØMM	Material no. for seal design CST3		
		M	T	S
40	28	R961008006	R961008032	R961008058
50	28	R961008008	R961008034	R961008060
	36	R961008009	R961008035	R961008061
63	36	R961008011	R961008037	R961008063
	45	R961008012	R961008038	R961008064
80	45	R961008014	R961008040	R961008066
	56	R961008015	R961008041	R961008067
100	56	R961008017	R961008043	R961008069
	70	R961008018	R961008044	R961008070
125	70	R961011581	R961011588	R961011596
	90	R961011582	R961011589	R961011597
160	70	R961011583	R961011590	R961011598
	110	R961011584	R961011591	R961011599
200	90	R961011585	R961011592	R961011601
	140	R961011586	R961011593	R961011602

ØAL = Piston Ø

ØMM = Piston rod Ø

¹⁾ Seal kits for position measurement system and subplate mounting separate material no.

Seal kits

Only for subplate mounting

Subplates NG	Material number for seal design	
	M, T	S
6	R961008236	R961008239
10, 16	R961011631	R961011632

Only for position measurement system

ØAL	Material number for seal design	
	M, T	S
40	R961008156	R961008161
50	R961008157	R961008162
63	R961008158	R961008163
80	R961008159	R961008164
100	R961008160	R961008165
125	R961011625	R961011626
160	R961011627	R961011628
200	R961011629	R961011630

Tightening torques

ØAL	ØMM	Tightening torques for tie rod nut in Nm for types of mounting	
		ME5/6, MP1/3/5, MS2, MT1/2/4, MX3/5	MX1/2
25	12	5.5	3
	18		
32	14	8	6.5
	22		
40	18	20	12
	22		
	28		
50	22	50	37
	28		
	36		
63	28	60	40
	36		
	45		
80	36	125	90
	45		
	56		
100	45	190	100
	56		
	70		
125	56	400	240
	70		
	90		
160	70	800	450
	110		
200	90	1250	600
	140		

Spare parts: Series CDT3

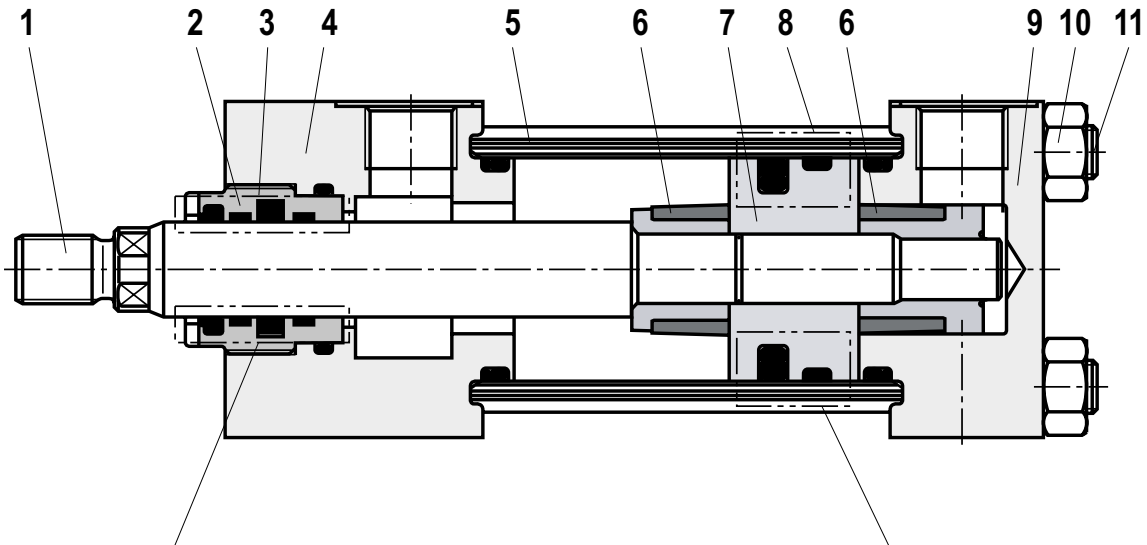

Piston rod seals

Ø25 – 32 and Ø40/18



Ø40/22, Ø40/28 and Ø50 – 200



Piston seals

M, T, S for piston Ø25 – 63

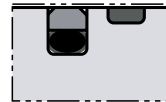

M, T, S for piston Ø80 – 200



- 1 Piston rod
- 2 Guide socket
- 3 Piston rod seal
- 4 Cylinder head
- 5 Cylinder pipe
- 6 Damping bush
- 7 Piston
- 8 Piston seal
- 9 Cylinder base
- 10 Nut
- 11 Tie rod

Spare parts: Series CGT3

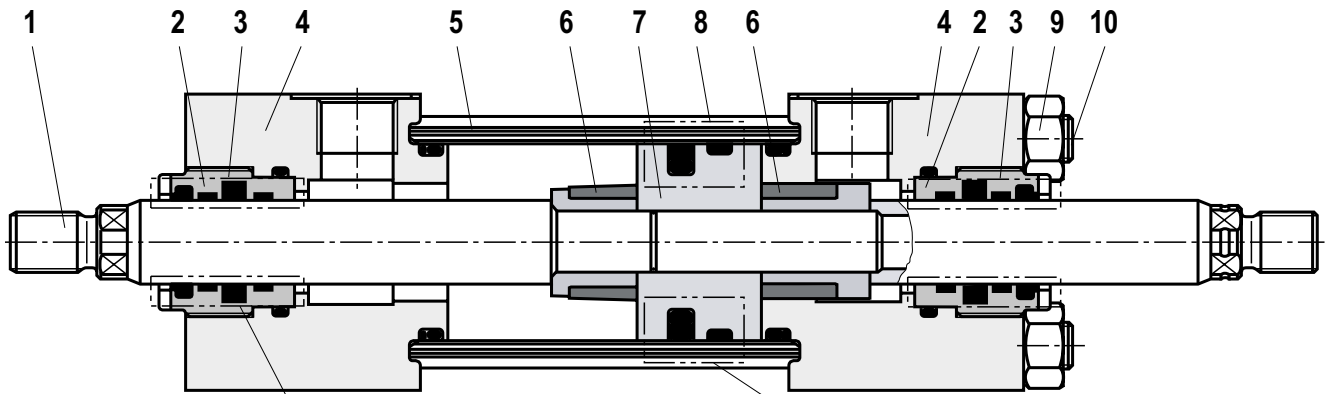

Piston rod seals

Ø25 – 32 and Ø40/18

M

T, S

Ø40/22, Ø40/28 and Ø50 – 200

M

T, S

Piston seals

M, T, S for piston Ø25 – 63

M, T, S for piston Ø80 – 200

- 1 Piston rod
- 2 Guide socket
- 3 Piston rod seal
- 4 Cylinder head
- 5 Cylinder pipe
- 6 Damping bush
- 7 Piston
- 8 Piston seal
- 9 Nut
- 10 Tie rod

Spare parts: Series CST3

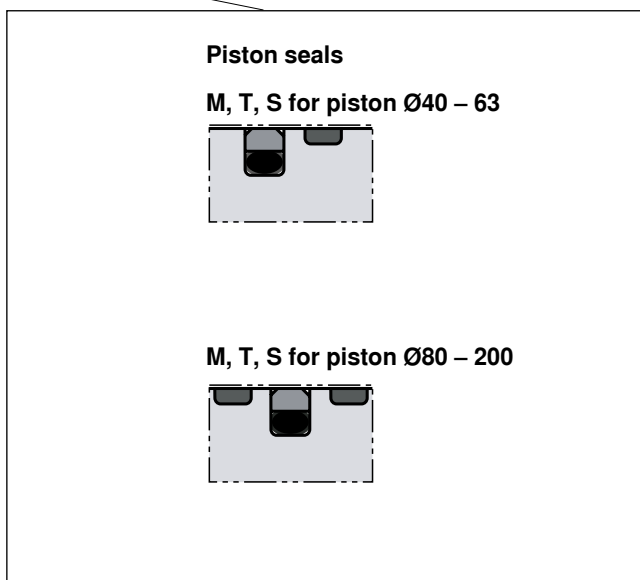
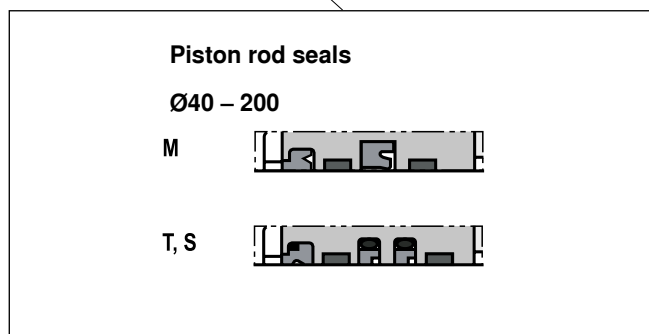
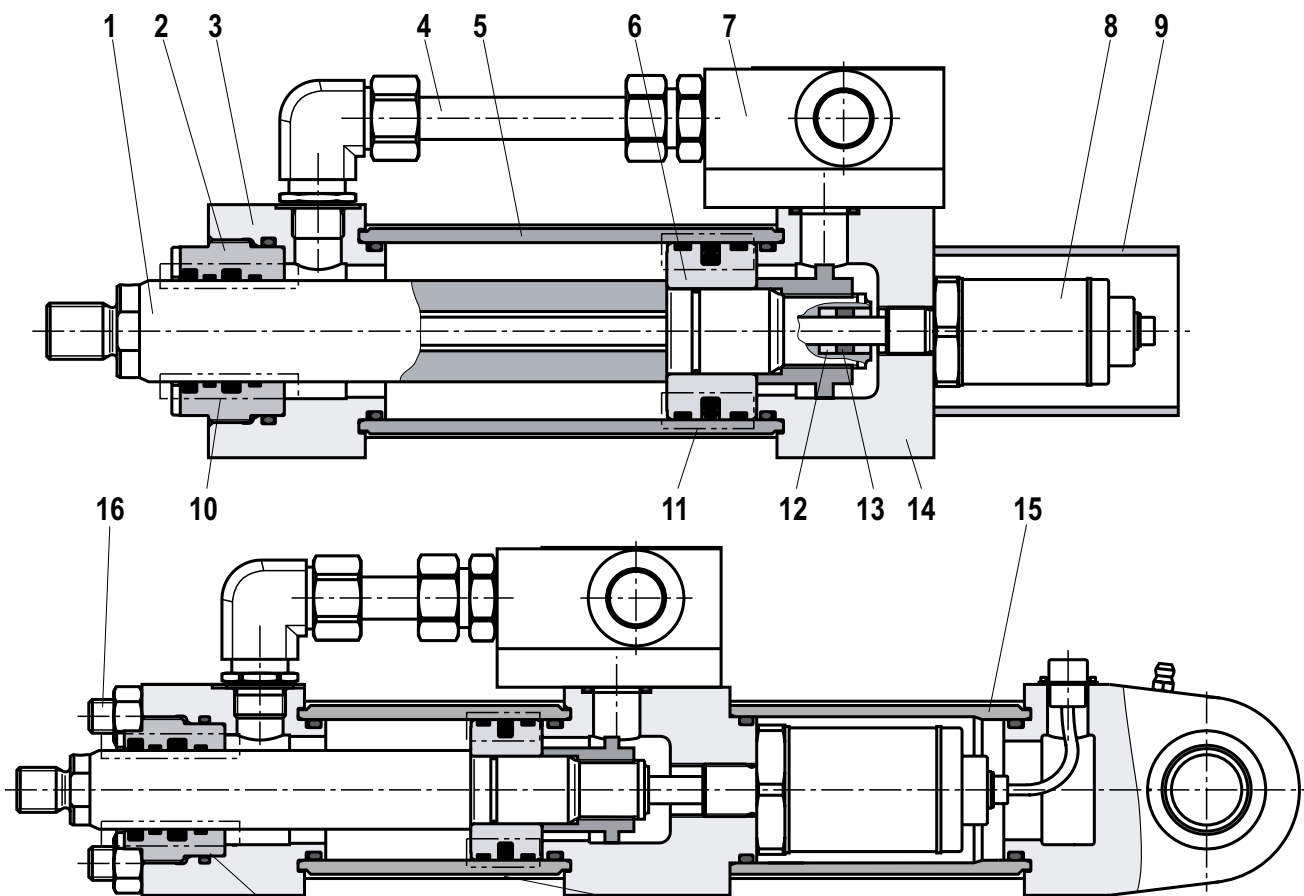

- | | | |
|-----------------|-------------------------------|----------------------|
| 1 Piston rod | 7 Subplate | 12 Insulating socket |
| 2 Guide socket | 8 Position measurement system | 13 Solenoid |
| 3 Cylinder head | 9 Protective pipe | 14 Cylinder base |
| 4 Piping | 10 Piston rod seal | 15 Connection pipe |
| 5 Cylinder pipe | 11 Piston seal | 16 Tie rod |

Weight for cylinder (in kg)

CDT3 / CGT3

ØAL	ØMM	MX1, ME5, MS2		ME6, MP3, MP1		MP5		MT4		MX2, MX3, MX5 (in case of CGT3 without MX2)		MT1, MT2 (in case of CGT3 without MT2)		Stroke 100 mm	
		CDT3	CGT3	CDT3	CGT3	CDT3	CGT3	CDT3	CGT3	CDT3	CGT3	CDT3	CGT3	CDT3	CGT3
25	12	1.1	1.2	1.1	-	1.0	-	1.3	1.4	1.0	1.1	1.1	1.2	0.4	0.5
	18	1.2	1.4	1.2	-	1.1	-	1.4	1.6	1.1	1.3	1.2	1.4	0.6	0.8
32	14	1.5	1.6	1.6	-	1.4	-	1.8	1.9	1.4	1.5	1.5	1.6	0.5	0.6
	22	1.6	1.9	1.7	-	1.5	-	1.9	2.2	1.5	1.8	1.6	1.9	0.6	0.9
40	18	3.4	3.6	3.4	-	3.2	-	4.1	4.3	3.1	3.3	3.2	3.4	0.8	1.0
	22 ¹²⁾	3.4	3.8	3.4	-	3.2	-	4.1	4.5	3.1	3.5	3.2	3.6	0.9	1.2
	28	3.5	4.0	3.5	-	3.3	-	4.2	4.7	3.2	3.7	3.3	3.8	1.1	1.6
50	22	5.3	5.7	5.3	-	4.9	-	6.6	7.0	4.8	5.2	4.9	5.3	1.1	1.4
	28 ¹²⁾	5.4	6.0	5.4	-	5	-	6.7	7.3	4.9	5.5	5	5.6	1.3	1.8
	36	5.5	6.4	5.5	-	5.1	-	6.8	7.7	5.0	5.9	5.1	6.0	1.6	2.4
63	28	7.7	8.3	7.7	-	7.3	-	9.2	9.8	7.0	7.6	7.3	7.9	1.4	1.9
	36 ¹²⁾	7.9	8.8	7.8	-	7.4	-	9.3	10.3	7.1	8.1	7.4	8.4	1.7	2.5
	45	8.2	9.7	8.0	-	7.6	-	9.5	11	7.3	8.8	7.6	9.1	2.2	3.4
80	36	14	15	14	-	14	-	18	19	12	13	15	15	2.2	3.0
	45 ¹²⁾	14	16	14	-	14	-	17	20	13	14	14	16	2.6	3.8
	56	15	17	15	-	15	-	19	21	14	16	15	17	3.3	5.2
100	45	20	22	20	-	20	-	24	26	19	20	22	24	3.3	4.5
	56 ¹²⁾	20	23	20	-	19	-	24	27	18	21	22	25	4.1	6.1
	70	21	25	21	-	21	-	25	29	19	23	23	27	5.1	8.1
125	56	38	41	39	-	38	-	46	49	35	39	43	46	6.3	8.2
	70 ¹²⁾	38	43	39	-	38	-	46	51	35	41	43	48	7.3	10.3
	90	39	46	40	-	39	-	48	55	37	44	44	51	9.3	14
160	70	62	68	67	-	63	-	78	83	59	65	64	69	8.7	12
	110	64	75	69	-	65	-	80	91	61	72	67	79	13.2	21
200	90	112	124	120	-	115	-	147	158	107	118	114	126	13.4	18
	140	115	137	123	-	117	-	149	171	109	131	117	138	20.5	33

Swivel head, clevis bracket and trunnion bearing block see pages 47 to 51

Subplates see page 44

¹²⁾ Piston rod Ø not standardized

Weight for cylinder (in kg)

CST3

ØAL	ØMM	ME5, MS2	MP5	MT4	MX5	Stroke 100 mm
40	28	3.5	3.8	4.2	3.2	1.1
50	28 ¹²⁾	5.4	5.8	6.7	4.9	1.3
	36	5.5	5.9	6.8	5.0	1.6
63	36 ¹²⁾	7.9	8.5	9.3	7.1	1.7
	45	8.2	8.7	9.5	7.3	2.2
80	45 ¹²⁾	14	16.1	17	13	2.6
	56	15	17.3	19	14	3.3
100	56 ¹²⁾	20	21.8	24	18	4.1
	70	21	24.1	25	19	5.1
125	70 ¹²⁾	38	43.7	46	35	7.3
	90	39	44.8	48	37	9.3
160	70	62	72.5	78	59	8.7
	110	64	74.8	80	61	13.2
200	90	112	132	147	107	13.4
	140	115	134.5	149	109	20.5

Swivel head, clevis bracket and trunnion bearing block see pages 47 to 51

¹²⁾ Piston rod Ø not standardized

Subplates see page 44