

Axial piston variable pump A10VSO Series 32

RE 92714

Edition: 08.2015

Replaces: 10.2014



- ▶ Sizes 45 to 180
- ▶ Nominal pressure 280 bar
- ▶ Maximum pressure 350 bar
- ▶ For industrial application areas
- ▶ Open circuit

Characteristics

- ▶ Variable pump with axial piston rotary group of swash-plate design for hydrostatic drives in open circuit
- ▶ Flow is proportional to the drive speed and displacement.
- ▶ The flow can be infinitely varied by adjusting the swash-plate angle.
- ▶ Hydrostatic unloading of the cradle bearings
- ▶ Connection for measuring sensor on the high-pressure port
- ▶ Low noise level
- ▶ Low pressure pulsation
- ▶ High efficiency
- ▶ High resistance against cavitation, loss of suction pressure and case pressure peaks
- ▶ Universal through drive

Contents

Ordering code	2
Hydraulic fluids	4
Operating pressure range	6
Technical data	7
DG – Two-point control, directly operated	11
DR – Pressure controller	12
DRG – Pressure controller, remotely operated	13
DRF/DRS – Pressure and flow controller	14
LA... – Pressure, flow and power controller	15
LA... – Variations	16
ED – Electro-hydraulic pressure control	17
ER – Electro-hydraulic pressure control	18
Dimensions, size 45 to 180	19
Dimensions through drive	34
Overview of attachment options	41
Combination pumps A10VSO + A10VSO	42
Connector for solenoids	43
Installation instructions	44
Project planning notes	47
Safety instructions	47

Ordering code

01	02	03	04	05	06	07	08	09	10	11	12	13
A10VS	O		/	32		-	V		B			

Axial piston unit

01	Variable swashplate design, nominal pressure 280 bar, maximum pressure 350 bar	A10VS
----	--	--------------

Operating mode

02	Pump, open circuit	O
----	--------------------	----------

Size (NG)

03	Geometric displacement, see "Technical data" on page 7	045	071	100	140	180
----	--	------------	------------	------------	------------	------------

Control devices

04	Two-point control, directly operated				•	•	•	•	•	DG
	Pressure controller	hydraulic			•	•	•	•	•	DR
			with flow controller	hydraulic	X-T open	•	•	•	•	•
	X-T plugged	•			•	•	•	•	DRS	
	pressure cut-off	hydraulic	remotely operated		•	•	•	•	•	DRG
			electrical	negative control		U = 12 V	•	•	•	•
	U = 24 V			•	•		•	•	•	ED72
	electrical	positive control		U = 12 V	•	•	•	•	•	ER71¹⁾
		U = 24 V			•	•	•	•	•	ER72²⁾
	Power controller with pressure cut-off	hydraulic	beginning of control	to 50 bar	•	•	•	•	•	LA5D
				from 51 to 90 bar	•	•	•	•	•	LA6D
				91 to 160 bar	•	•	•	•	•	LA7D
				160 to 240 bar	•	•	•	•	•	LA8D
				above 240 bar	•	•	•	•	•	LA9D
	remotely operated	hydraulic	beginning of control	see LA.D	•	•	•	•	•	LA.DG
flow control, X-T plugged	hydraulic	beginning of control	see LA.D	•	•	•	•	•	LA.DS	
			electrically over-ridable (negative control)	see LA.D	•	•	•	•	•	LA.S

Series

05	Series 3, index 2	32
----	-------------------	-----------

Directions of rotation

06	Viewed on drive shaft	clockwise	R
		counter-clockwise	L

Seal

07	FKM (fluoroelastomer)	V
----	-----------------------	----------

Drive shafts

08	Parallel keyed shaft DIN 6885 limited suitability for through drive (see table of values, page 9)				•	•	•	•	•	P
	Splined shaft	Standard shaft		•	•	•	•	•	•	S
		ANSI B92.1a	similar to shaft "S" however for higher input torque		•	•	-	-	-	R

Mounting flange

09	ISO 3019-2; 4-hole	B
----	--------------------	----------

1) The following must be taken into account during project planning:
Excessive current levels ($I > 1200$ mA at 12 V or $I > 600$ mA at 24 V) to the ER solenoid can result in undesired pressure increases which can lead to pump or system damage. Therefore:

- Use I_{max} current limiter solenoids.
- A intermediate plate pressure controller can be used to protect the pump in the event of overflow.
An accessory kit with intermediate plate pressure controller can be ordered from Rexroth under part number R902490825.

Ordering code

01	02	03	04	05	06	07	08	09	10	11	12	13
A10VS	O			/	32		-	V		B		

Service line ports

			045	071	100	140	180	
10	SAE flange ports at top, at bottom, on opposite side, metric fastening thread with universal through drive	without pulsation damping	●	●	●	●	○	22U
		with pulsation damping, not for high-speed	●	●	●	●	●	32U

Through drives¹⁾ (for fitting options, see page 41)

			045	071	100	140	180	
11	Flange ISO 3019-2 ²⁾	Hub for splined shaft ³⁾						
	Diameter	Attachment ⁵⁾	Diameter					
Without through drive ⁴⁾			●	●	●	●	●	00
	ISO 80, 2-hole	⌀, ⌀ ^o , ∞	3/4 in	11T 16/32DP	●	●	●	B2
	ISO 100, 2-hole	⌀, ⌀ ^o , ∞	7/8 in	13T 16/32DP	●	●	●	B3
	ISO 125, 4-hole	⌀ ^o	1 in	15T 16/32DP	●	●	●	E1
	ISO 160, 4-hole	⌀ ^o	1 1/4 in	14T 12/24DP	-	●	●	B8
	ISO 180, 4-hole	⌀ ^o	1 1/2 in	17T 24/24DP	-	-	●	B9
		⌀ ^o	1 3/4 in	13T 8/16DP	-	-	●	B7
Flange ISO 3019-1 ²⁾			Hub for splined shaft ³⁾					
Diameter			Diameter					
	82-2 (A)	⌀, ⌀ ^o , ∞	5/8 in	9T 16/32DP	●	●	●	01
		⌀, ⌀ ^o , ∞	3/4 in	11T 16/32DP	●	●	●	52
	101-2 (B)	⌀, ⌀ ^o , ∞	7/8 in	13T 16/32DP	●	●	●	68
		⌀, ⌀ ^o , ∞	1 in	15T 16/32DP	●	●	●	04
	127-4 (C)	⌀ ^o	1 in	15T 16/32DP	●	●	●	E2
		⌀ ^o	1 1/4 in	14T 12/24DP	-	●	●	15
	127-2 (C)	⌀, ⌀ ^o , ∞	1 1/2 in	17T12/24DP	-	-	●	24
	152-4 (D)	⌀ ^o	1 1/2 in	17T 12/24DP	-	-	●	96
		⌀ ^o	1 3/4 in	13T 8/16DP	-	-	●	17

Rotary group version

12	Standard rotary group (noise-optimized for n= 1,500/1,800 rpm)	●	●	●	●	●	E
	High-speed (with port plate version 22U only)	●	●	●	●	-	S

Connector for solenoids

13	Without connector (without solenoid, with hydraulic control only, without code)	
	HIRSCHMANN connector – without suppressor diode	H

● = Available ○ = On request - = Not available

Note

Note the project planning notes on page 47.

1) See data sheet 95581

2) 2-hole: Attachment pump series 31

4-hole: Attachment pump series 32

3) According to ANSI B92.1a (splined shafts according to SAE J744)

4) With through-drive shaft, without hub, without intermediate flange, closed on a functionally reliable basis with cover

5) Mounting through bores pattern viewed from through drive with control at top

Hydraulic fluids

The A10VSO variable pump is designed for operation with HLP mineral oil according to DIN 51524.

Application instructions and requirements for hydraulic fluids should be taken from the following data sheets before the start of project planning:

- ▶ 90220: Hydraulic fluids based on mineral oils and related hydrocarbons
- ▶ 90221: Environmentally acceptable hydraulic fluids
- ▶ 90222: Fire-resistant, water-free hydraulic fluids (HFDR/HFDU)

Details regarding the selection of hydraulic fluid

The hydraulic fluid should be selected such that the operating viscosity in the operating temperature range is within the optimum range (v_{opt} , see selection diagram).

Note

At no point of the component may the temperature be higher than 90 °C. The temperature difference specified in the table is to be taken into account when determining the viscosity in the bearing.

If the above conditions cannot be maintained due to extreme operating parameters, please contact the responsible member of staff at Bosch Rexroth.

Viscosity and temperature of hydraulic fluids

	viscosity	temperature	Comment
Cold start	$v_{max} \leq 1000 \text{ mm}^2/\text{s}$	$\theta_{St} \geq -25 \text{ }^\circ\text{C}^{1)}$	$t \leq 3 \text{ min}$, without load ($p \leq 30 \text{ bar}$)
	Permissible temperature difference	$\Delta T \leq 13 \text{ K}$	between axial piston unit and hydraulic fluid
Warm-up phase	$v < 1000 \text{ to } 400 \text{ mm}^2/\text{s}$	$\theta = \text{at } -25 \text{ }^\circ\text{C}$	For detailed information on operation at low temperatures, see data sheet 90300-03-B.
Operating phase	$v = 400 \text{ to } 16 \text{ mm}^2/\text{s}$	$\theta = -25 \text{ }^\circ\text{C to } +85 \text{ }^\circ\text{C}$	This corresponds, for example on the VG 46, to a temperature range of +5 °C to +70 °C (see selection diagram)
	$v_{opt} = 36 \text{ to } 16 \text{ mm}^2/\text{s}$		measured at port L observe permissible temperature range of the shaft seal ring ($\Delta T = \text{approx. } 5 \text{ K}$ between bearing/shaft seal and port L)
Short-term operation	$v_{min} \geq 10 \text{ mm}^2/\text{s}$		$t < 3 \text{ min}$, $p < 0.3 \cdot p_{nom}$

▼ Selection diagram

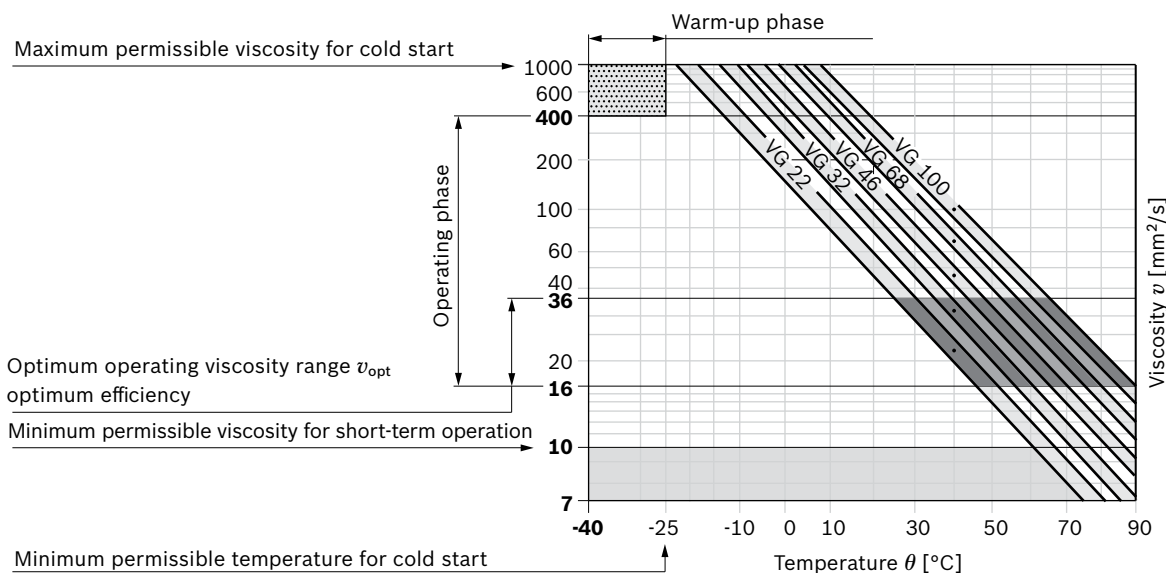

- 1) Special measures are necessary at temperatures between -40 °C and -25 °C. Please contact us.
For detailed information on operation at low temperatures, see data sheet 90300-03-B.

Filtration of the hydraulic fluid

Finer filtration improves the cleanliness level of the hydraulic fluid, which increases the service life of the axial piston unit.

A cleanliness level of at least 20/18/15 according to ISO 4406 is to be adhered to.

Please contact us if the above classes cannot be observed.

Operating pressure range

Pressure at service line port B		Definition	
Nominal pressure p_{nom}	280 bar absolute	The nominal pressure corresponds to the maximum design pressure.	
Maximum pressure p_{max}	350 bar absolute	The maximum pressure corresponds the maximum operating pressure within the single operating period. The sum of the single operating periods must not exceed the total operating period.	
Single operating period	2.5 ms		
Total operating period	300 h		
Minimum pressure (high-pressure side)	10 bar ¹⁾ absolute	Minimum pressure on the high-pressure side (B) which is required in order to prevent damage to the axial piston unit.	
Rate of pressure change $R_{A\ max}$	16000 bar/s	Maximum permissible rate of pressure build-up and reduction during a pressure change over the entire pressure range.	
Pressure at suction port S (inlet)			
Minimum pressure $p_{S\ min}$	Standard	0.8 bar absolute	Minimum pressure at suction port S (inlet) that is required in order to avoid damage to the axial piston unit. The minimum pressure depends on the speed and displacement of the axial piston unit.
	High-speed	1.0 bar absolute	
Maximum pressure $p_{S\ max}$	10 bar ²⁾ absolute		
Case pressure at port L ₁ , L ₂			
Maximum pressure $p_{L\ max}$	2 bar absolute	Maximum 0.5 bar higher than inlet pressure at port S, but not higher than $p_{L\ max}$. A case drain line to the reservoir is required.	

▼ Rate of pressure change $R_{A\ max}$

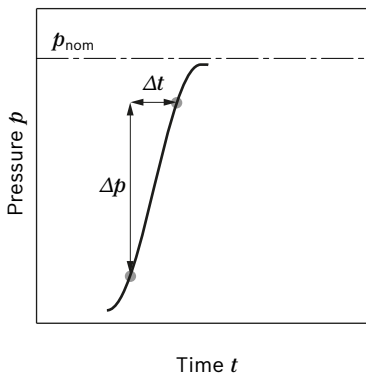

▼ Pressure definition

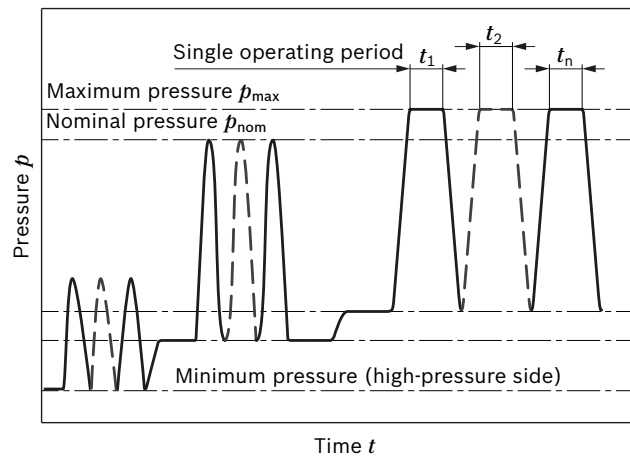

Total operating period = $t_1 + t_2 + \dots + t_n$

Note

Operating pressure range valid when using hydraulic fluids based on mineral oils. Please contact us for values for other hydraulic fluids.

1) Lower pressure is time-dependent, please contact us
2) Other values on request

Technical data

Standard rotary group, version E

Size	NG		45	71	100	140	180	
Displacement, geometric, per revolution	$V_{g \max}$	cm ³	45	71	100	140	180	
Maximum rotational speed ¹⁾	at $V_{g \max}$ n_{nom}	rpm	1800 ²⁾	1800 ²⁾	1800 ²⁾	1800 ³⁾	1800 ³⁾	
Flow	at n_{nom} and $V_{g \max}$	q_v	l/min	81	128	180	252	324
	at $n_E = 1500$ rpm	q_{vE}	l/min	67.5	106.7	150	210	270
Power	at n_{nom} , $V_{g \max}$ and $\Delta p = 280$ bar	P	kW	38	59.7	84	118	151
	at $n_E = 1500$ rpm	P_E	kW	31	50	70	98	125
Torque	at $V_{g \max}$ and $\Delta p = 280$ bar	T	Nm	200	317	446	624	802
	at $V_{g \max}$ and $\Delta p = 100$ bar	T	Nm	72	113	159	223	286
Rotary stiffness drive shaft	P	c	Nm/rad	34587	80627	132335	188406	213022
	S	c	Nm/rad	29497	71884	121142	169537	171107
	R	c	Nm/rad	41025	76545	–	–	–
Moment of inertial rotary group	J_{TW}	kgm ²	0.0035	0.0087	0.0185	0.0276	0,033	
Maximum angular acceleration ⁴⁾	α	rad/s ²	4000	2900	2400	2000	2000	
Case volume	V	L	1.0	1.6	2.2	3.0	2.7	
Weight (approx.)	m	kg	30	47	69	73	78	

Calculation of characteristics

Flow	$q_v = \frac{V_g \times n \times \eta_v}{1000}$	[l/min]
Torque	$T = \frac{V_g \times \Delta p}{20 \times \pi \times \eta_{hm}}$	[Nm]
Power	$P = \frac{2 \pi \times T \times n}{60000} = \frac{q_v \times \Delta p}{600 \times \eta_t}$	[kW]

Key

V_g	Displacement per revolution [cm ³]
Δp	Differential pressure [bar]
n	Rotational speed [rpm]
η_v	Volumetric efficiency
η_{hm}	Hydraulic mechanical efficiency
η_t	Total efficiency ($\eta_t = \eta_v \times \eta_{hm}$)

Note

- ▶ Theoretical values, without efficiency and tolerances; values rounded.
- ▶ Exceeding the maximum or falling below the minimum permissible values can lead to a loss of function, a reduction in operational service life or total destruction of the axial piston unit. Bosch Rexroth recommend testing the load by means of experiment or calculation/simulation and comparison with the permissible values.

- 1) The values are valid:
 - for the optimum viscosity range from $\nu_{opt} = 36$ to 16 mm²/s
 - with hydraulic fluid on the basis of mineral oils
- 2) The values apply at absolute pressure $p_{abs} = 0.8$ bar at suction port S
- 3) The values apply at absolute pressure $p_{abs} = 1.0$ bar at suction port S

- 4) The data are valid at values between the minimum required and maximum permissible speed. Valid for external excitation (e.g., diesel engine 2 to 8 times rotary frequency; Cardan shaft twice the rotary frequency). The limiting value is only valid for a single pump. The load capacity of the connection parts must be considered.

Technical data

High-speed rotary group, version S

Size		NG	45	71	100	140	
Displacement, geometric, per revolution		$V_{g \max}$	cm ³	45	71	100	140
Maximum rotational speed ¹⁾	at $V_{g \max}$	n_{nom}	rpm	3000 ²⁾	2550 ²⁾	2300 ²⁾	2200 ²⁾
Flow	at n_{nom} and $V_{g \max}$	q_v	l/min	135	181	230	308
	at $n_E = 1500$ rpm	q_{vE}	l/min	67.5	106.7	150	210
Power	at n_{nom} , $V_{g \max}$ and $\Delta p = 280$ bar	P	kW	62.8	85	107	144
	at $n_E = 1500$ rpm	P_E	kW	31	50	70	98
Torque	at $V_{g \max}$ and $\Delta p = 280$ bar	T	Nm	200	317	446	624
	at $V_{g \max}$ and $\Delta p = 100$ bar	T	Nm	72	113	159	223
Rotary stiffness	Drive shaft P	c	Nm/rad	34587	80627	132335	188406
	Drive shaft S	c	Nm/rad	29497	71884	121142	169537
	Drive shaft R	c	Nm/rad	41025	76545	–	–
Moment of inertial rotary group		J_{TW}	kgm ²	0.0035	0.0087	0.0185	0.0276
Maximum angular acceleration ³⁾		α	rad/s ²	4000	2900	2400	2400
Case volume		V	L	1.0	1.6	2.2	3.0
Weight (approx.)		m	kg	30	47	69	73

Calculation of characteristics			
Flow	q_v	$= \frac{V_g \times n \times \eta_v}{1000}$	[l/min]
Torque	T	$= \frac{V_g \times \Delta p}{20 \times \pi \times \eta_{hm}}$	[Nm]
Power	P	$= \frac{2 \pi \times T \times n}{60000} = \frac{q_v \times \Delta p}{600 \times \eta_t}$	[kW]

Key

- V_g Displacement per revolution [cm³]
- Δp Differential pressure [bar]
- n Rotational speed [rpm]
- η_v Volumetric efficiency
- η_{hm} Hydraulic mechanical efficiency
- η_t Total efficiency ($\eta_t = \eta_v \times \eta_{hm}$)

Note

- Theoretical values, without efficiency and tolerances; values rounded.
- Exceeding the maximum or falling below the minimum permissible values can lead to a loss of function, a reduction in operational service life or total destruction of the axial piston unit. Bosch Rexroth recommend testing the load by means of experiment or calculation/simulation and comparison with the permissible values.

1) The values are valid:
– for the optimum viscosity range from $\nu_{opt} = 36$ to 16 mm²/s
– with hydraulic fluid on the basis of mineral oils
2) The values apply at absolute pressure $p_{abs} = 1.0$ bar at suction port S

3) The data are valid at values between the minimum required and maximum permissible speed. Valid for external excitation (e.g., diesel engine 2 to 8 times rotary frequency; Cardan shaft twice the rotary frequency). The limiting value is only valid for a single pump. The load capacity of the connection parts must be considered.

Permissible radial and axial forces of the drive shafts

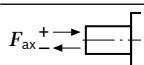
Size		NG	45	71	100	140	180	
Maximum radial force at a/2		$F_{q \max}$	N	1,00	1900	2300	2800	2300
Maximum axial force		$\pm F_{ax \max}$	N	1500	2400	4000	4800	800

Note

For drives with radial loading (pinion, V-belt drives), please contact us!

Permissible input and through-drive torques

Size			45	71	100	140	180
Torque at $V_{g \max}$ and $\Delta p = 280 \text{ bar}^1$	T_{max}	Nm	200	317	446	624	802
Input torque at drive shaft, maximum ²⁾							
P	$T_{E \max}$	Nm	200	439	857	1206	1243
	\varnothing	mm	25	32	40	45	45
S	$T_{E \max}$	Nm	319	626	1104	1620	1620
	\varnothing	in	1	1 1/4	1 1/2	1 3/4	1 3/4
R	$T_{E \max}$	Nm	400	644	–	–	–
	\varnothing	in	1	1 1/4	–	–	–
Maximum through-drive torque							
P	$T_{D \max}$	Nm	200	439	778	1206	1243
S	$T_{D \max}$	Nm	319	492	778	1266	1266
R	$T_{D \max}$	Nm	365	548	–	–	–

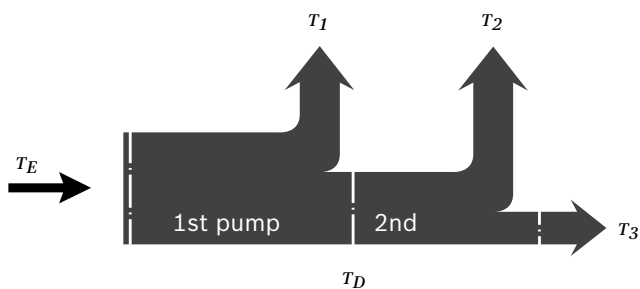
▼ Torque distribution

Torque at 1st pump	T_1
Torque at 2nd pump	T_2
Torque at 3rd pump	T_3
Input torque	$T_E = T_1 + T_2 + T_3$
	$T_E < T_{E \max}$
Through-drive torque	$T_D = T_2 + T_3$
	$T_D < T_{D \max}$

1) Efficiency not considered

2) For drive shafts with no radial force

Drive power and flow

Size 45

- n = 1500 rpm
- n = 1800 rpm

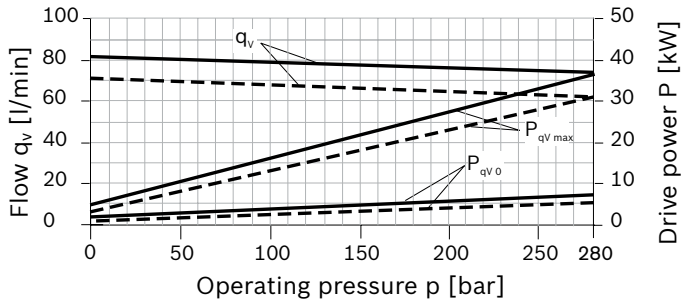

Size 71

- n = 1500 rpm
- n = 1800 rpm

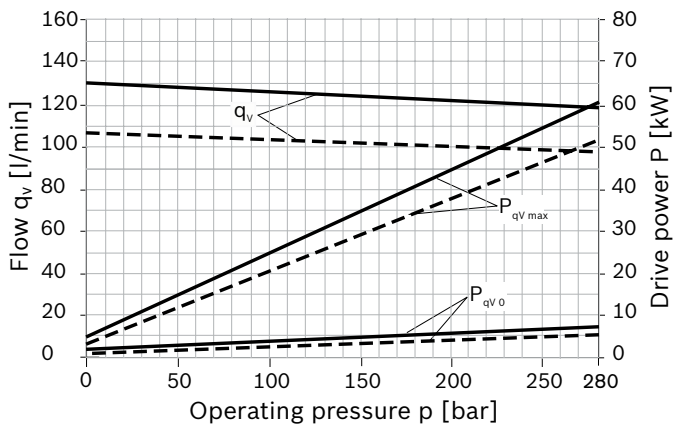

Size 100

- n = 1500 rpm
- n = 1800 rpm

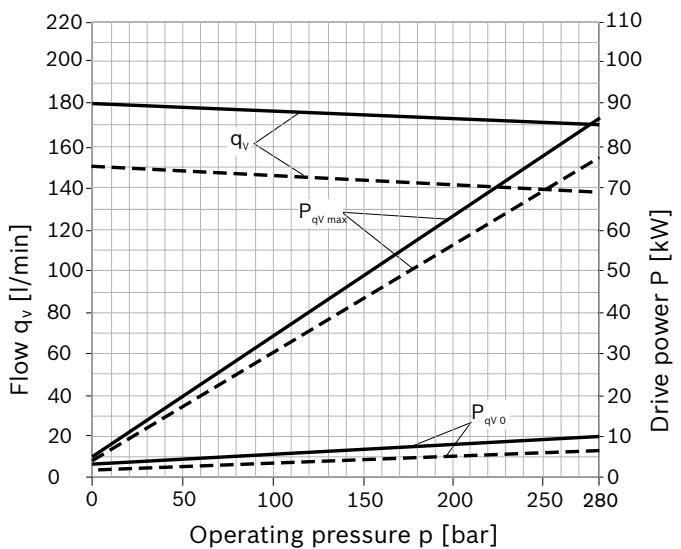

Note
 ► Characteristic curves measured using ISO VG 46 DIN 51519 hydraulic fluid and $\theta = 50\text{ }^\circ\text{C}$

Size 140

- n = 1500 rpm
- n = 1800 rpm

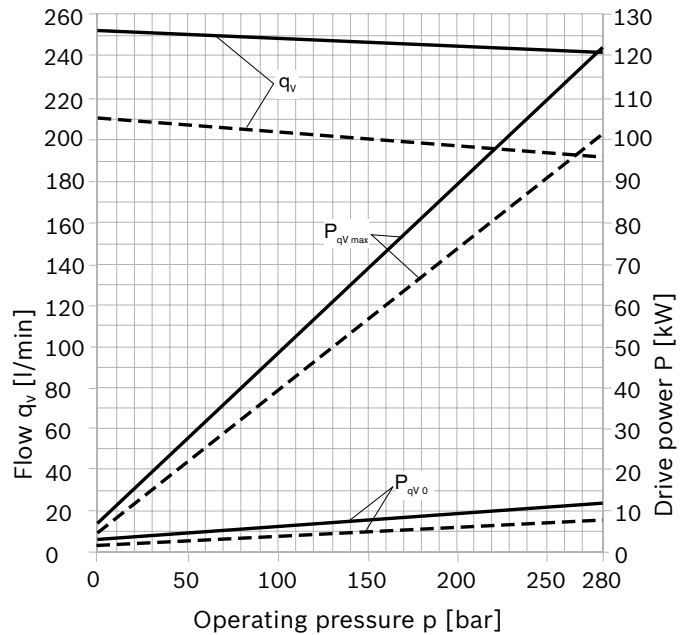

Size 180

- n = 1500 rpm
- n = 1800 rpm

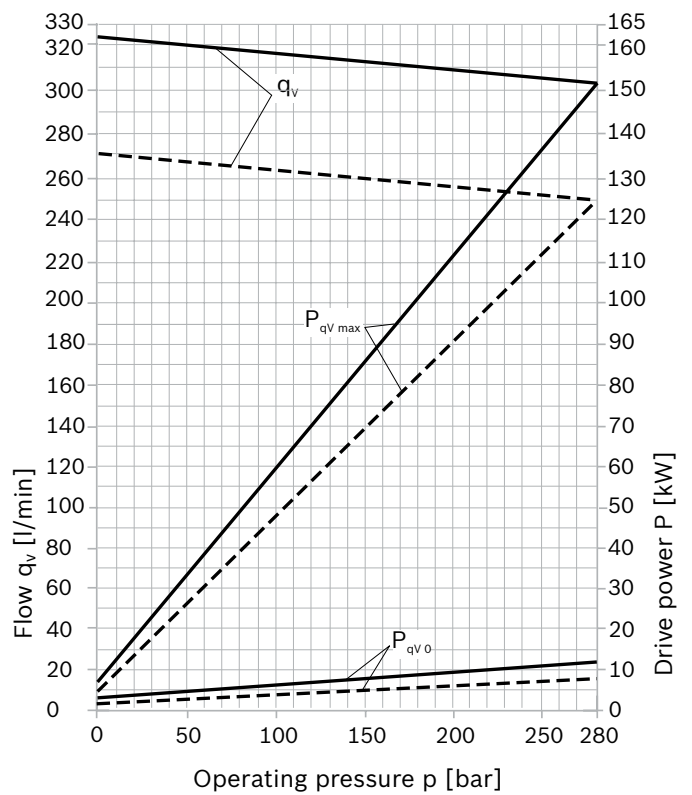

DG – Two-point control, directly operated

The variable pump can be set to a minimum swivel angle by connecting an external control pressure to port **X**.

This will supply control fluid directly to the stroke piston; a minimum control pressure of $p_{st} \geq 50$ bar is required.

The variable pump can only be switched between $V_{g\ min}$ and $V_{g\ max}$.

Please note, that the required control pressure at port **X** is directly dependent on the actual operating pressure p_B at port **B**. (See control pressure characteristic).

The maximum permissible control pressure is 280 bar.

- ▶ Control pressure p_{st} in $X = 0$ bar $\triangleq V_{g\ max}$
- ▶ Control pressure p_{st} in $X \geq 50$ bar $\triangleq V_{g\ min}$

▼ Control pressure characteristic curve

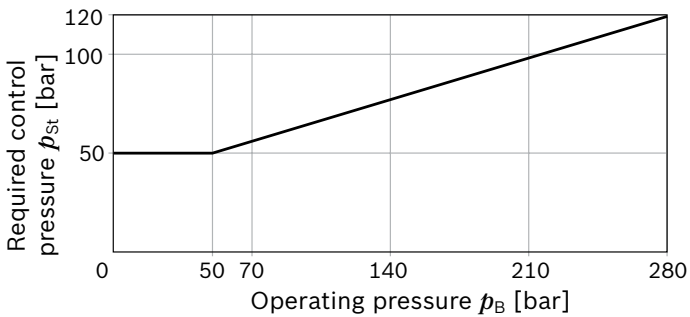

▼ Circuit diagram DG

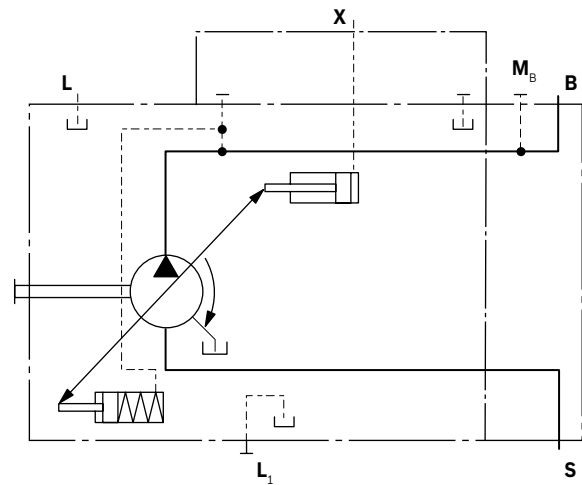

DR – Pressure controller

The pressure controller limits the maximum pressure at the pump outlet within the control range of the variable pump. The variable pump only supplies as much hydraulic fluid as is required by the consumers. If the operating pressure exceeds the pressure setting at the pressure valve, the pump will regulate to a smaller displacement to reduce the control differential.

- ▶ Basic position in depressurized state: $V_{g \max}$.
- ▶ Setting range¹⁾ for pressure control 20 to 280 bar standard is 280 bar.

▼ Characteristic curve DR

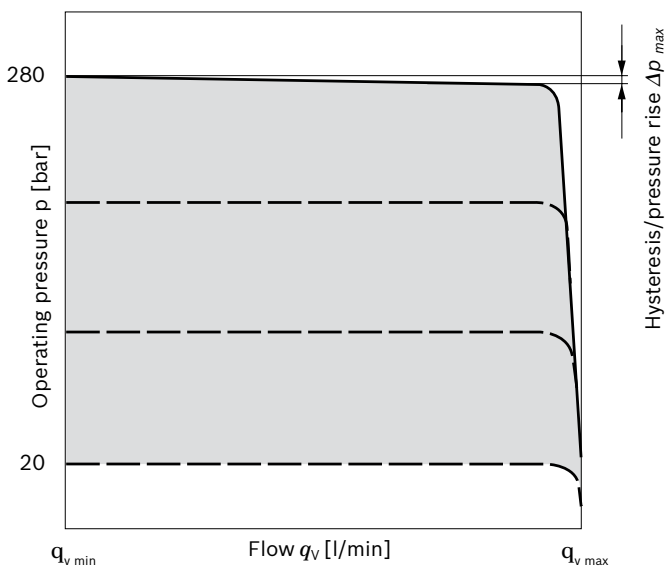

Characteristic curve valid at $n_1 = 1500$ rpm and $t_{\text{fluid}} = 50$ °C.

▼ Circuit diagram DR

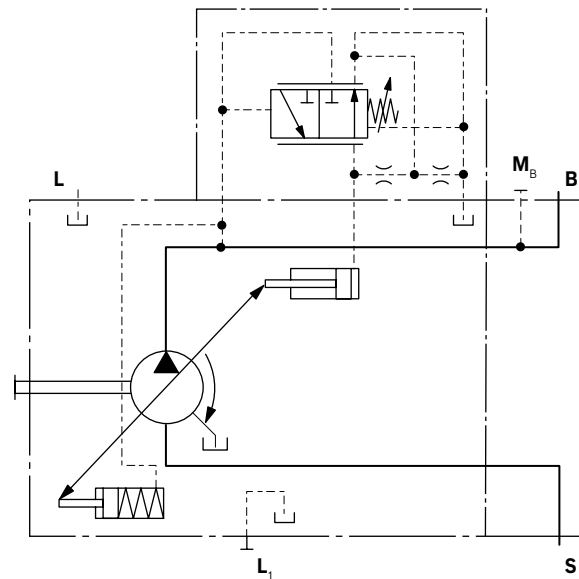

Controller data

NG		45	71	100	140	180
Pressure rise, maximum	Δp [bar]	6	8	10	12	14
Hysteresis and repeatability	Δp [bar]	maximum 3				
Pilot fluid consumption	l/min	maximum approx. 3				

Flow losses at $q_{v \max}$ see page 10.

¹⁾ In order to prevent damage to the pump and the system, the permissible setting range must not be exceeded. The range of possible settings at the valve is higher.

DRG – Pressure controller, remotely operated

For the remote-controlled pressure controller, the target pressure can be set using a separately arranged pressure relief valve. Pressure controller DR see page 12.

A pressure relief valve can be externally piped to port **X** for remote setting of pressure below the setting of the DR control valve spool. This relief valve is not included in the scope of supply of the pump.

The differential pressure at the DRG control valve is set as standard to 20 bar. At port **X** the amount of control fluid is about 1.5 l/min. If a different setting (range 10 to 22 bar) is required, please state in plain text.

As a separate pressure relief valve, we recommend:

- ▶ a directly controlled, hydraulic or electric proportional one, suitable for the control fluid mentioned above.

The max. length of piping should not exceed 2 m.

- ▶ Basic position in depressurized state: $V_{g \max}$.
- ▶ Setting range¹⁾ for pressure control 20 to 280 bar.

▼ Characteristic curve DRG

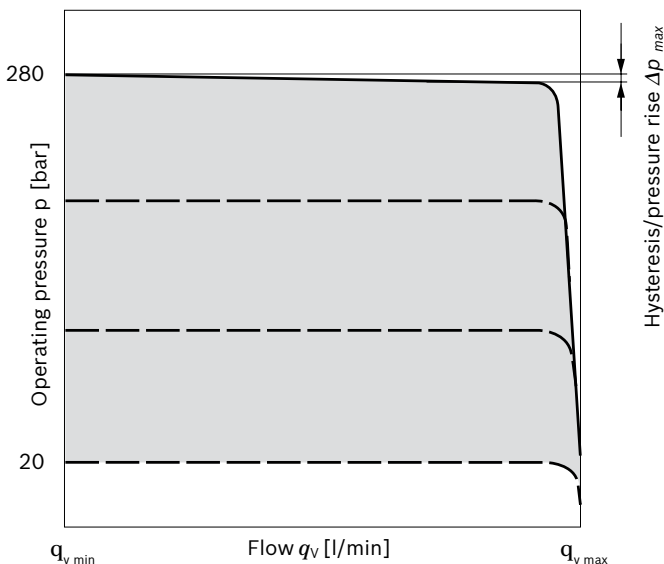

Characteristic curve valid at $n_1 = 1500$ rpm and $t_{\text{fluid}} = 50$ °C.

▼ Circuit diagram DRG

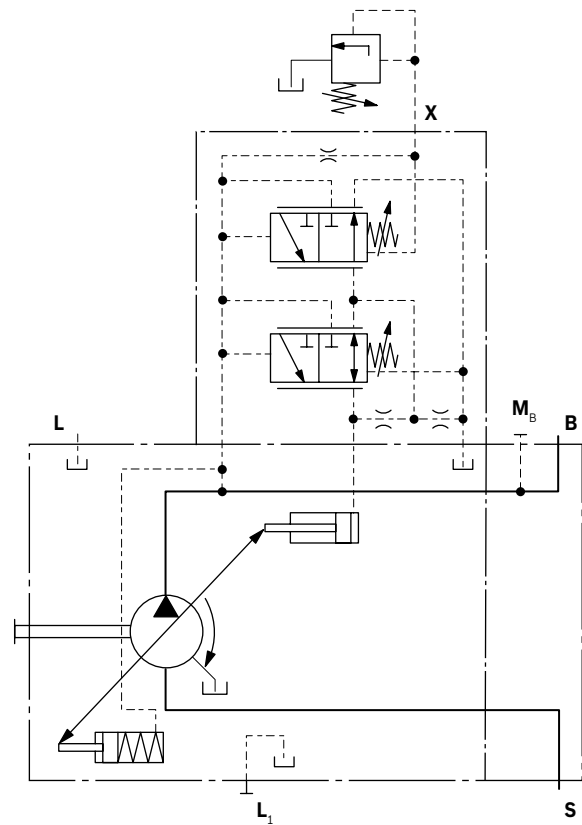

Controller data

NG		45	71	100	140	180
Pressure rise, maximum	Δp [bar]	6	8	10	12	14
Hysteresis and repeatability	Δp [bar]	maximum 3				
Pilot fluid consumption	l/min	maximum approx. 4.5				

Flow losses at $q_{v \max}$ see page 10.

¹⁾ In order to prevent damage to the pump and the system, the permissible setting range must not be exceeded. The range of possible settings at the valve is higher.

DRF/DRS – Pressure and flow controller

In addition to the pressure controller function (see page 12), a variable orifice (e.g. directional valve) is used to adjust the differential pressure upstream and downstream of the orifice. This is used to control the pump flow. The pump flow is equal to the actual required flow by the consumer, regardless of changing pressure levels. The pressure controller overrides the flow control function.

Note

The DFR1 version has no connection from **X** to the reservoir so the LS relief has to be incorporated into the system. Because of the flushing function, sufficient unloading of the **X**-line must also be provided.

- ▶ Basic position in depressurized state: $V_{g \max}$.
- ▶ Setting range¹⁾ for pressure control 20 to 280 bar standard is 280 bar.

▼ Characteristic curve DRF/DRS

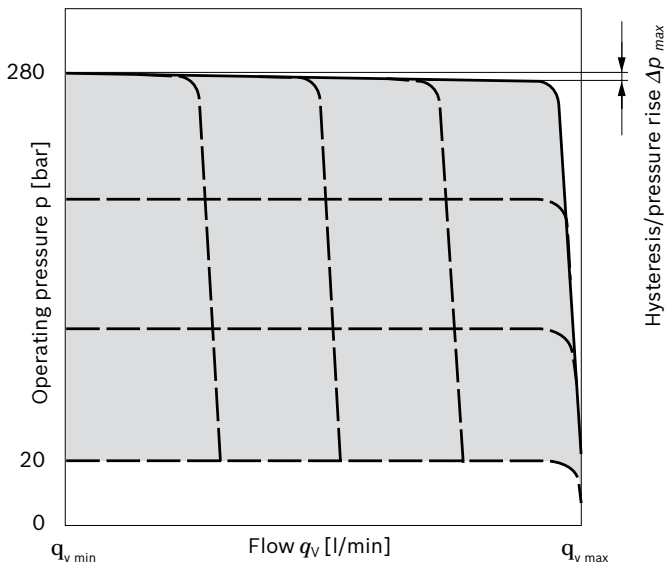

▼ Characteristic curve at variable speed

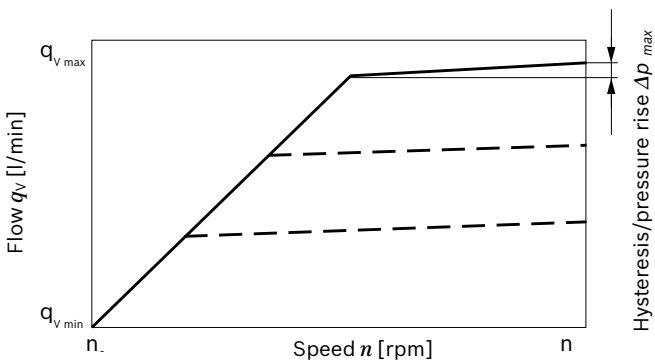

Characteristic curves valid at $n_1 = 1500$ rpm and $t_{\text{fluid}} = 50$ °C.

▼ Circuit diagram DG

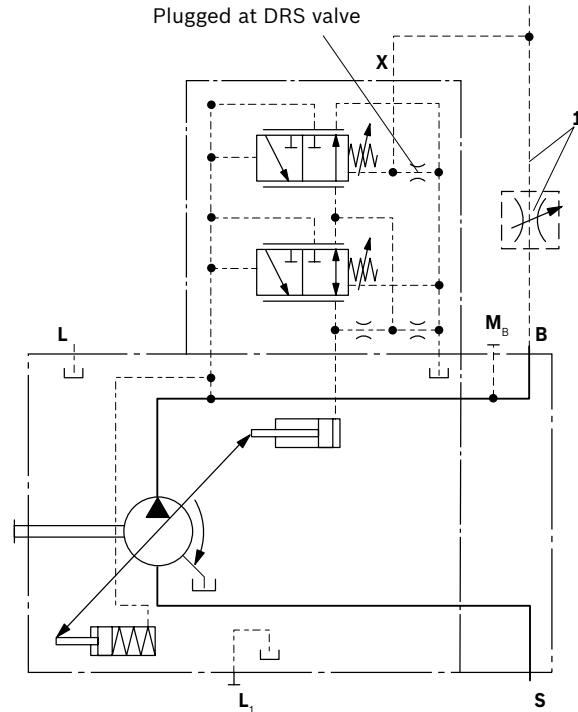

1 The measuring orifice (control block) is not included in the scope of supply.

Differential pressure Δp

The differential pressure at the DRG control valve is set as standard to 14 bar. At port **X** the amount of control fluid is approx. 1.5 l/min. If a different setting (range 10 to 22 bar) is required, please state in plain text.

Unloading port **X** to the reservoir results in a zero stroke (standby) pressure which is about 1 to 2 bar higher than the defined differential pressure Δp . System influences are not taken into account.

Controller data

DR pressure controller data see page 12.

Maximum flow deviation measured at drive speed $n = 1500$ rpm.

NG		45	71	100	140	180
Pressure rise, maximum	Δp [bar]	6	8	10	12	14
Hysteresis and repeatability	Δp [bar]	maximum 3				
Pilot fluid consumption	l/min	maximum approx. 4.5				
Flow deviation	$\Delta q_{v \max}$ [l/min]	1.8	2.8	4.0	6.0	8.0

1) In order to prevent damage to the pump and the system, the permissible setting range must not be exceeded. The range of possible settings at the valve is higher.

LA... – Pressure, flow and power controller

Pressure controller equipped as DR(G), see page 12 (13).
 Equipment of the flow controller like DRS, see page 14.
 In order to achieve a constant drive torque with varying operating pressures, the swivel angle and with it the output flow from the axial piston pump is varied so that the product of flow and pressure remains constant. Flow controller is possible below the power control curve.

When ordering please state the power characteristics to be set at the factory in clear text, e.g. 20 kW at 1,500 rpm.

Controller data

For technical data of pressure controller DR see page 12.

For technical data of flow controller FR see page 14.

Control fluid consumption max. approx. 5.5 l/min

Beginning of control	Torque T [Nm] for size					Ordering code
	45	71	100	140	180	
up to 50 bar	up to 42.0	up to 67.0	up to 94.0	up to 132.0	up to 167.0	LA5
51 to 90 bar	42.1 × 76.0	67.1 × 121.0	94.1 × 169.0	132.1 × 237.0	167.1 × 302.0	LA6
91 to 160 bar	76.1 × 134.0	121.1 × 213.0	169.1 × 299.0	237.1 × 418.0	302.1 × 540.0	LA7
161 to 240 bar	134.1 × 202.0	213.1 × 319.0	299.1 × 449.0	418.1 × 629.0	540.1 × 810.0	LA8
over 240 bar	over 202.1	over 319.1	over 449.1	over 629.1	over 810.1	LA9

Conversion of the torque values in power [kW]

$$P = \frac{T}{6.4} \text{ [kW]} \quad (\text{at } 1500 \text{ rpm})$$

or

$$P = \frac{2\pi \times T \times n}{60000} \text{ [kW]} \quad (\text{For rotational speeds see page 7})$$

▼ Characteristic curve LA.DS

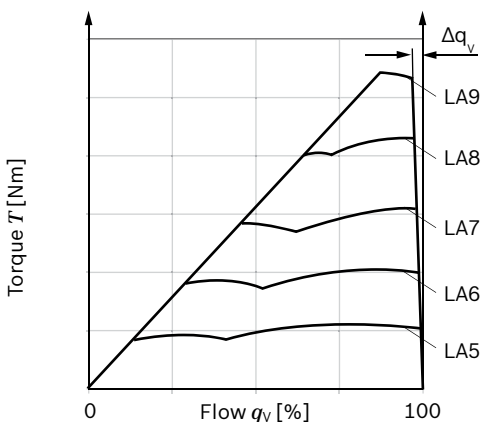
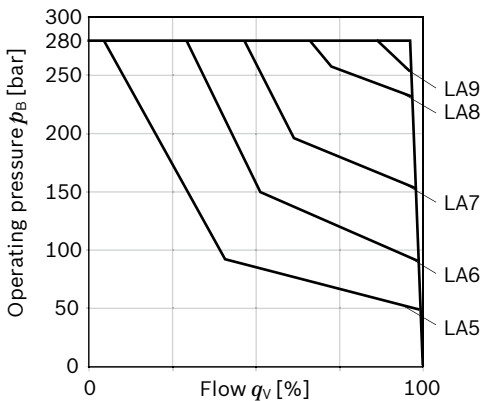

▼ Circuit diagram LA.DS

(for further combination options with LA.. see page 16)

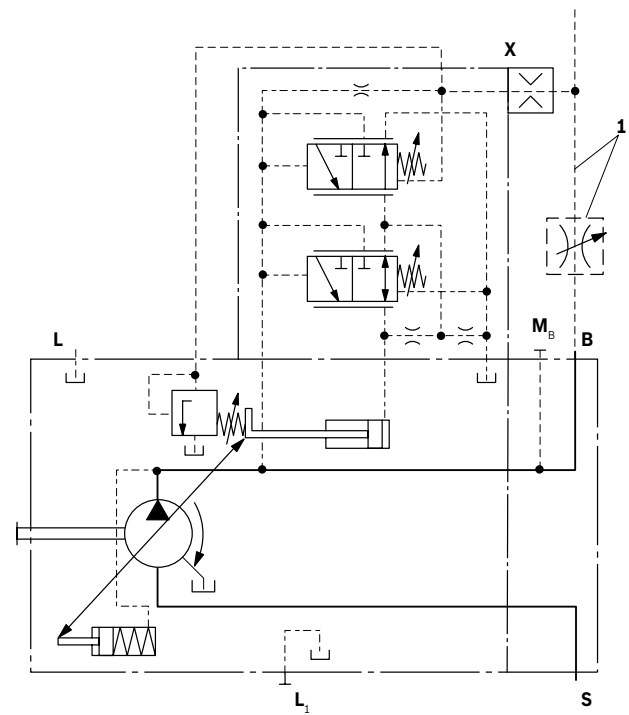

1 The measuring orifice is not included in the scope of supply.

LA... – Variations

▼ Circuit diagram LA.D with pressure cut-off

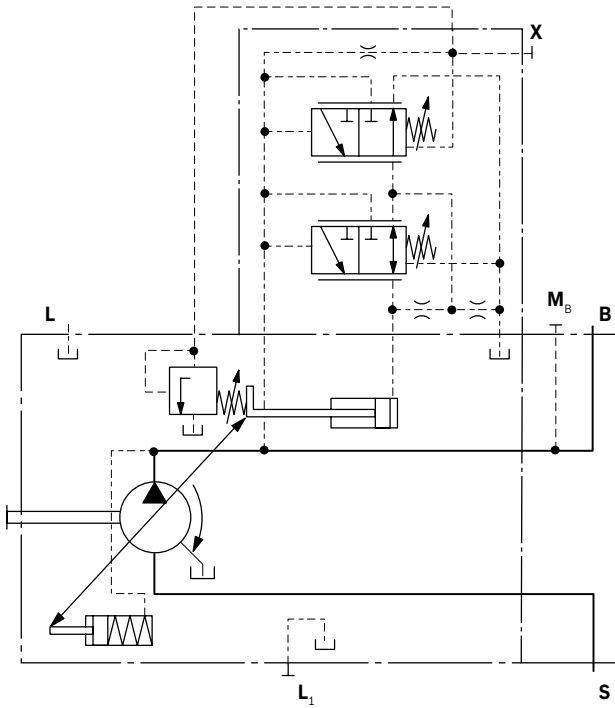

▼ Circuit diagram LA.S with separate flow control

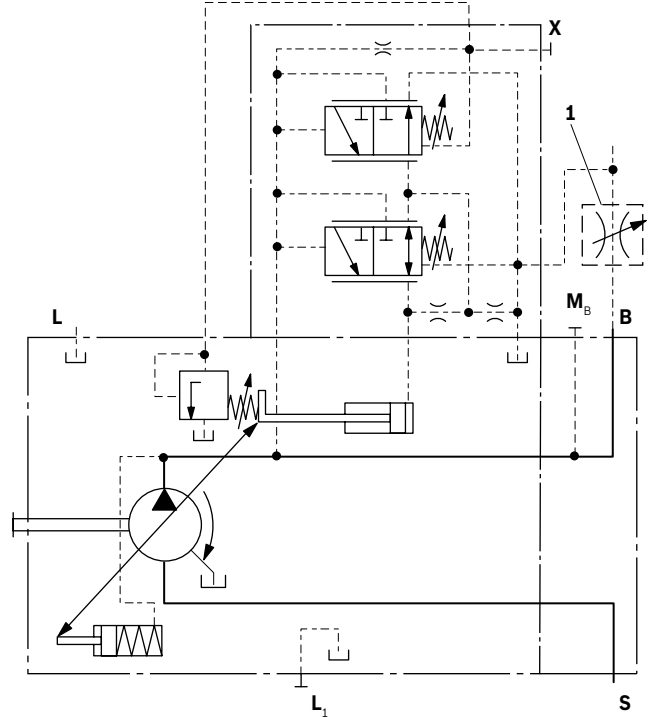

1 The measuring orifice is not included in the scope of supply.

▼ Circuit diagram LA.DG with pressure cut-off, remotely operated

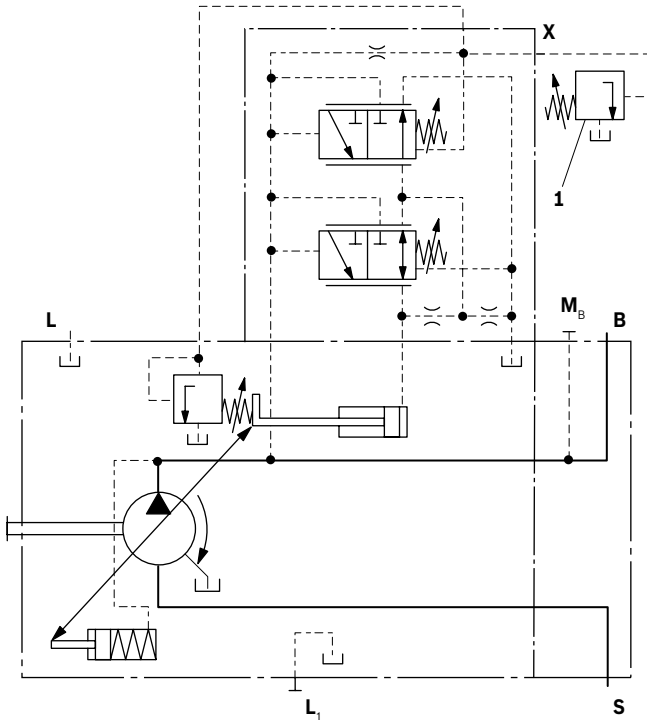

1 The measuring orifice is not included in the scope of supply.

ED – Electro-hydraulic pressure control

The ED valve is set to a certain pressure by a specified variable solenoid current.

When a change is made at the consumer (load pressure), the position of the control piston will shift.

This causes an increase or decrease in the pump swivel angle (flow) in order to maintain the electrically set pressure level. The pump thus only delivers as much hydraulic fluid as the consumers can take. The desired pressure level can be set steplessly by varying the solenoid current.

As the solenoid current signal drops towards zero, the pressure will be limited to p_{max} by an adjustable hydraulic pressure cut-off (secure fail safe function in case of a loss of power, e.g. for fan drives). The response time characteristic curve of the ED-control was optimized for the use as a fan drive system.

When ordering, specify the type of application in clear text.

▼ Static current-pressure characteristic curve ED

(negative characteristic curve measured with pump in zero stroke)

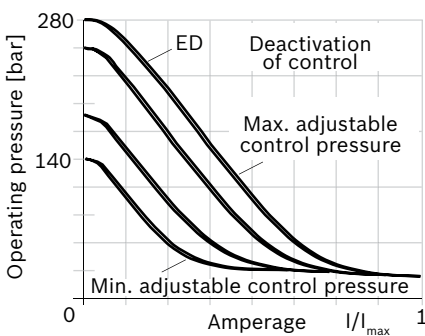

Hysteresis static current-pressure characteristic curve < 3 bar.

▼ Flow-pressure characteristic curve

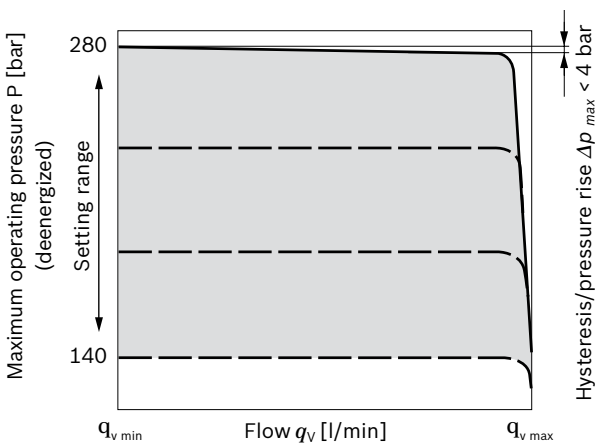

Characteristic curves valid at $n_1 = 1500$ rpm and $t_{fluid} = 50$ °C. Pilot fluid consumption: 3 to 4.5 l/min.

For standby standard setting, see diagram on right, other values on request.

▼ Influence of the pressure setting on standby (maximally energized)

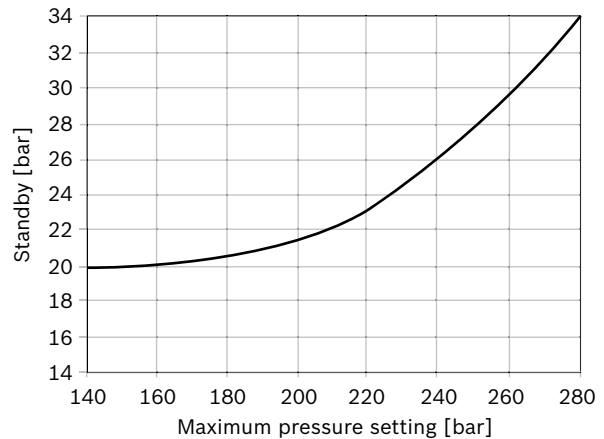

▼ Circuit diagram ED71/ED72

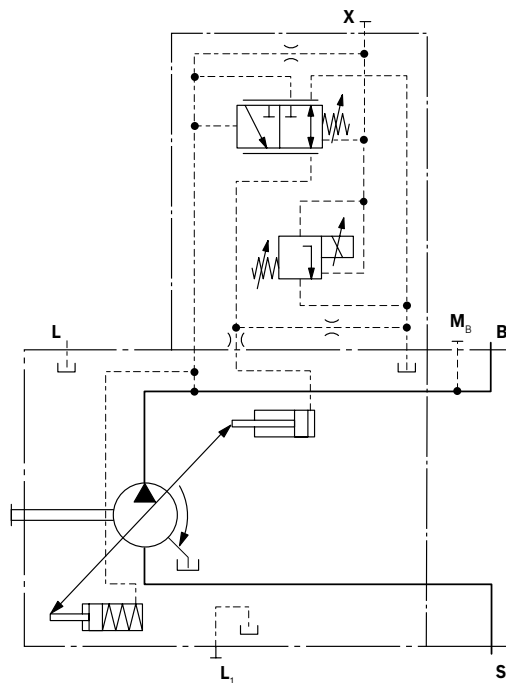

Technical data, solenoid	ED71	ED72
Voltage	12 V (±20%)	24 V (±20%)
Control current		
Start of control at p_{max}	100 mA	50 mA
Start of control at p_{min}	1200 mA	600 mA
Current limit	1.54 A	0.77 A
Nominal resistance (at 20 °C)	5.5 Ω	22.7 Ω
Dither frequency	100 to 200 Hz	100 to 200 Hz
Duty cycle	100%	100%
Type of protection: see connector version page 43		

Operating temperature range at valve -20 °C to +115 °C

ER – Electro-hydraulic pressure control

The ER valve is set to a certain pressure by a specified variable solenoid current.

When a change is made at the consumer (load pressure), the position of the control piston will shift.

This causes an increase or decrease in the pump swivel angle (flow) in order to maintain the electrically set pressure level.

The pump thus only delivers as much hydraulic fluid as the consumers can take. The desired pressure level can be set steplessly by varying the solenoid current.

As the solenoid current signal drops towards zero, the pressure will be limited to p_{min} (stand by).

Observe the project planning notes on page 2.

▼ Static current-pressure characteristic curve ER (positive characteristic curve measured with pump in zero stroke)

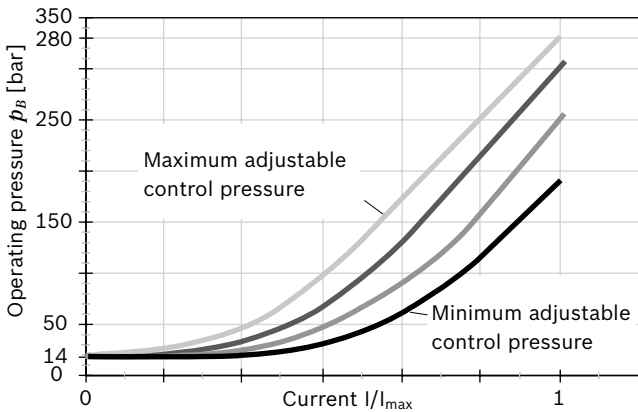

Hysteresis static current-pressure characteristic curve < 3 bar.
Influence of pressure setting on stand-by ± 2 bar

▼ Flow-pressure characteristic curve

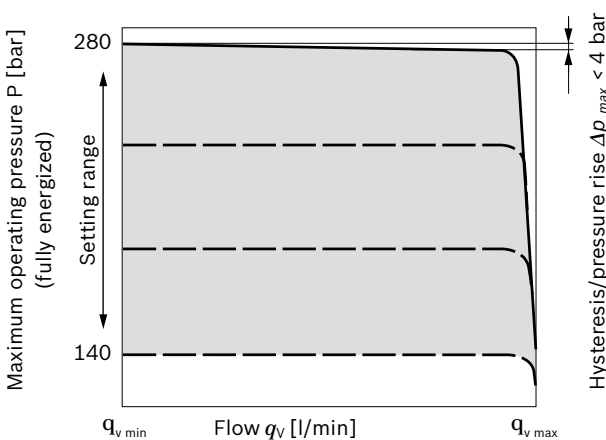

Characteristic curves valid at $n_1 = 1500$ rpm and $t_{fluid} = 50$ °C.
Pilot fluid consumption: 3 to 4.5 l/min.
Standby standard 14 bar. Other values on request.

▼ Circuit diagram ER71/ER72

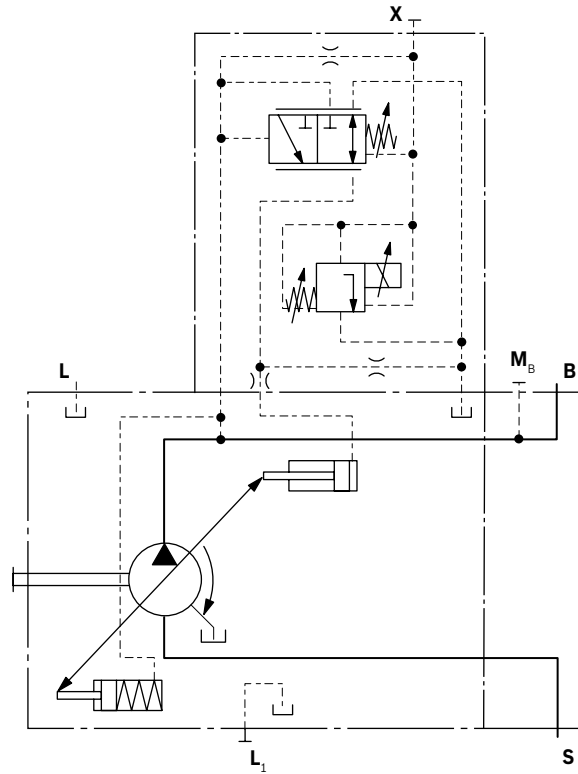

Technical data, solenoid	ED71	ED72
Voltage	12 V ($\pm 20\%$)	24 V ($\pm 20\%$)
Control current		
Start of control at p_{min}	100 mA	50 mA
End of control at p_{max}	1200 mA	600 mA
Current limit	1.54 A	0.77 A
Nominal resistance (at 20 °C)	5.5 Ω	22.7 Ω
Dither frequency	100 to 200 Hz	100 to 200 Hz
Duty cycle	100%	100%
Type of protection: see connector version page 43		

Operating temperature range at valve -20 °C to +115 °C

Dimensions, size 45

DR – Pressure controller

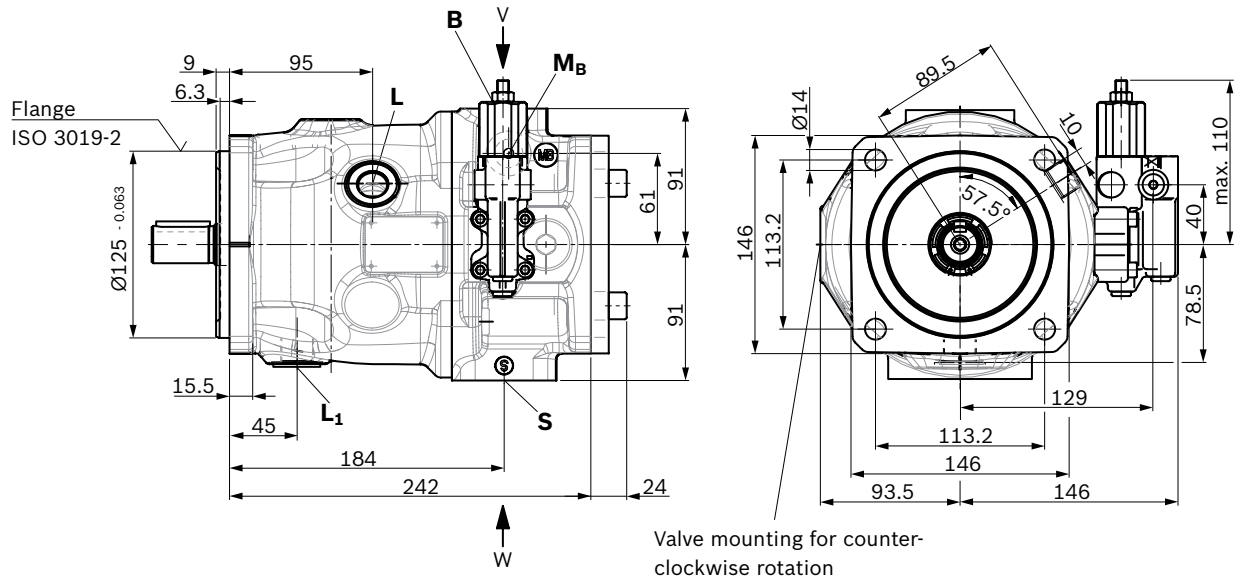

Detail W

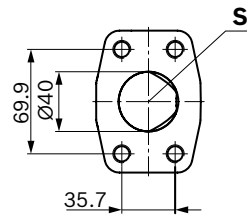

Detail V

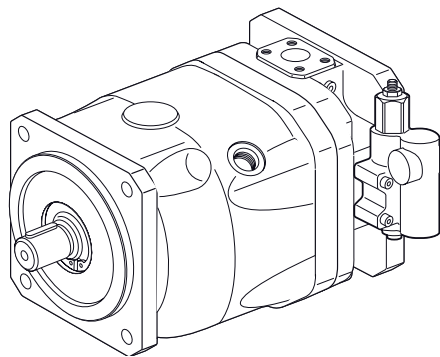
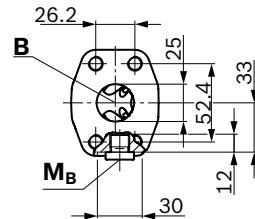

▼ Splined shaft 1 in (SAE J744)

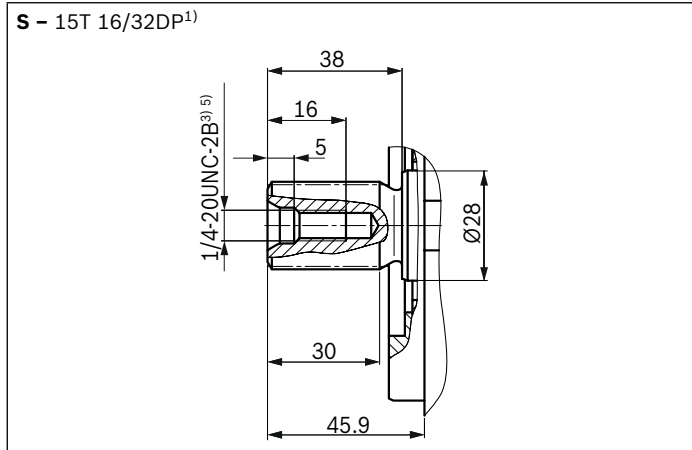

▼ Splined shaft 1 in (SAE J744)

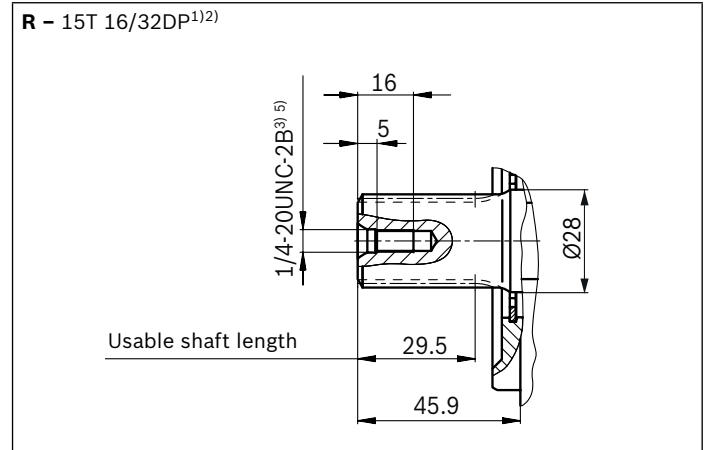

▼ Parallel keyed shaft DIN 6885

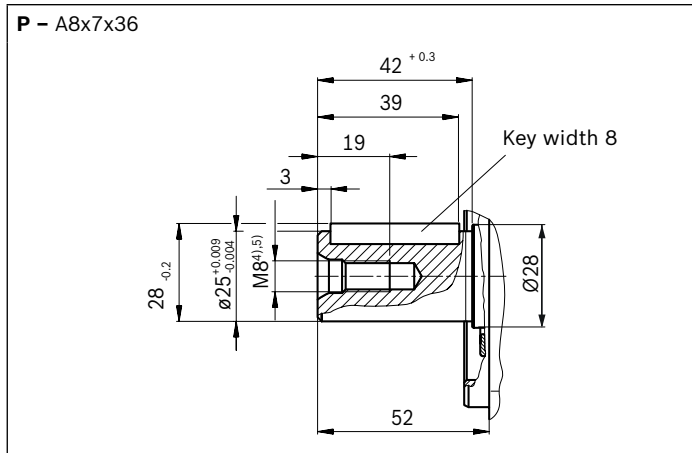

Ports		Standard	Size ⁵⁾	p_{\max} [bar] ⁶⁾	Condition ¹⁰⁾
B	Service line port (standard pressure series) Fastening thread	SAE J518 ⁷⁾ DIN 13	1 in M10 x 1.5, 17 deep	350	O
S	Suction port (standard pressure series) Fastening thread	SAE J518 ⁷⁾ DIN 13	1 1/2 in M12 x 1.75; 20 deep	10	O
L	Drain port	DIN 3852 ⁸⁾	M22 x 1.5; 14 deep	2	O ⁹⁾
L₁	Drain port	DIN 3852 ⁸⁾	M22 x 1.5; 14 deep	2	X ⁹⁾
X	Control pressure	DIN 3852	M14 x 1.5; 12 deep	350	O
X	Pilot pressure (with DG-control)	DIN ISO 228	G 1/4 in; 12 deep	280	O
M_B	Measuring pressure B	DIN 3852 ⁸⁾	G 1/4 in; 12 deep	350	X

- 1) Involute spline according to ANSI B92.1a, 30° pressure angle, flat root, side fit, tolerance class 5
- 2) Splines according to ANSI B92.1a, run out of spline is a deviation from standard.
- 3) Thread according to ASME B1.1
- 4) Center bore according to DIN 332 (thread according to DIN 13)
- 5) Observe the general instructions on page 47 concerning the maximum tightening torques.

- 6) Depending on the application, momentary pressure peaks may occur. Keep this in mind when selecting measuring devices and fittings.
- 7) Metric fixing thread differing from standard
- 8) The spot face can be deeper than as specified in the standard.
- 9) Depending on the installation position, L or L₁ must be connected (also see installation instructions starting on page 44).
- 10) O = Must be connected (plugged on delivery)
X = Plugged (in normal operation)

▼ **DG – Two-point control, directly operated**

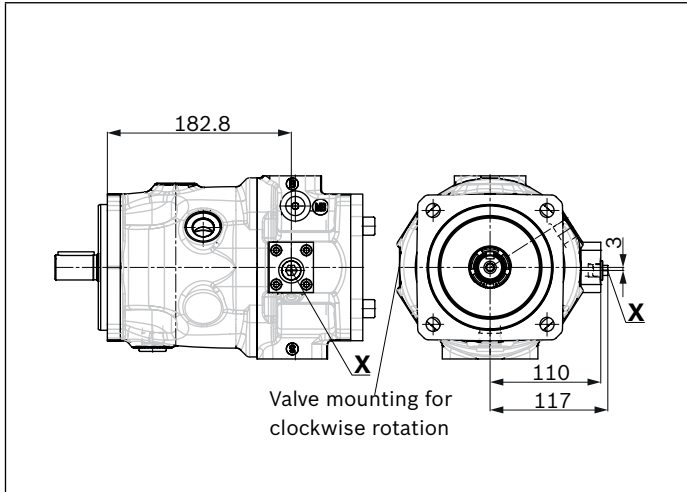

▼ **LA.DS – Pressure, flow and power control**

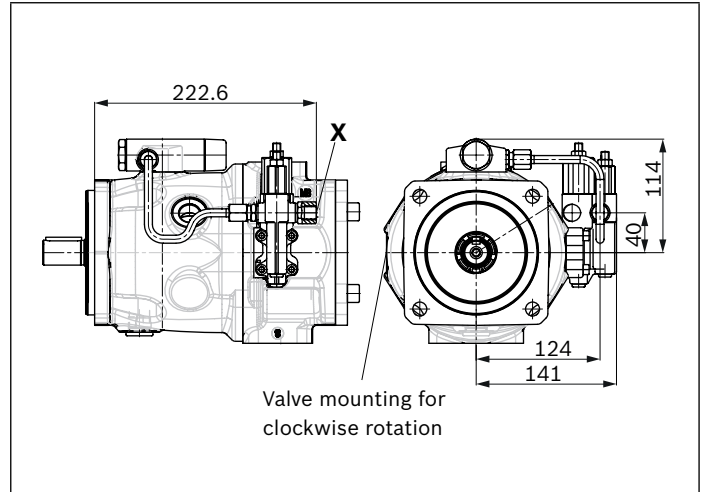

▼ **DRG – Pressure controller, remotely operated**

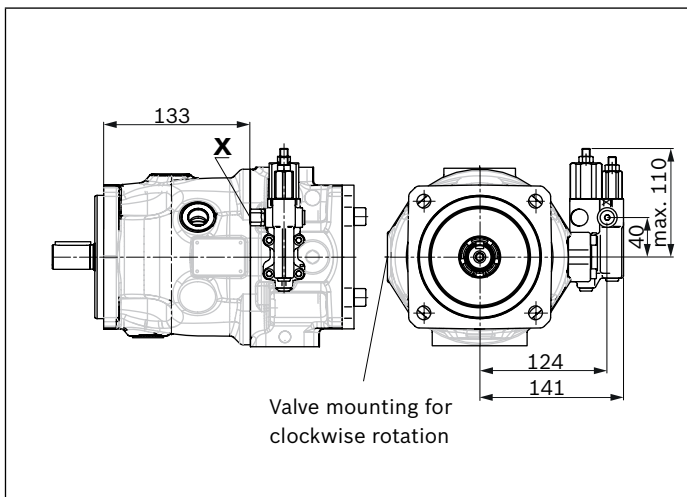

▼ **ED7./ER7. – Pressure controller, electrical**

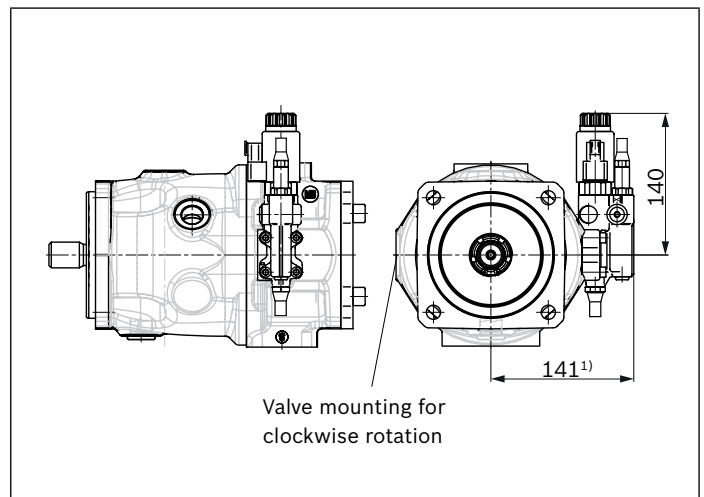

▼ **DRF/DRS – Pressure and flow controller**

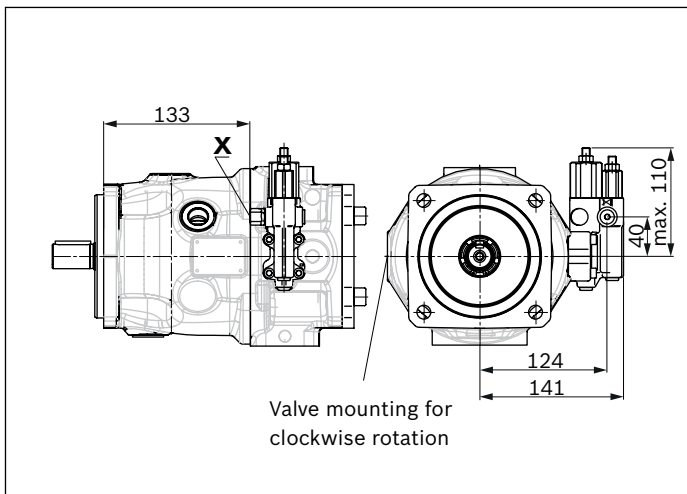

1) ER7.: 176 mm if using an intermediate plate pressure controller

Dimensions, size 71

DR – Pressure controller

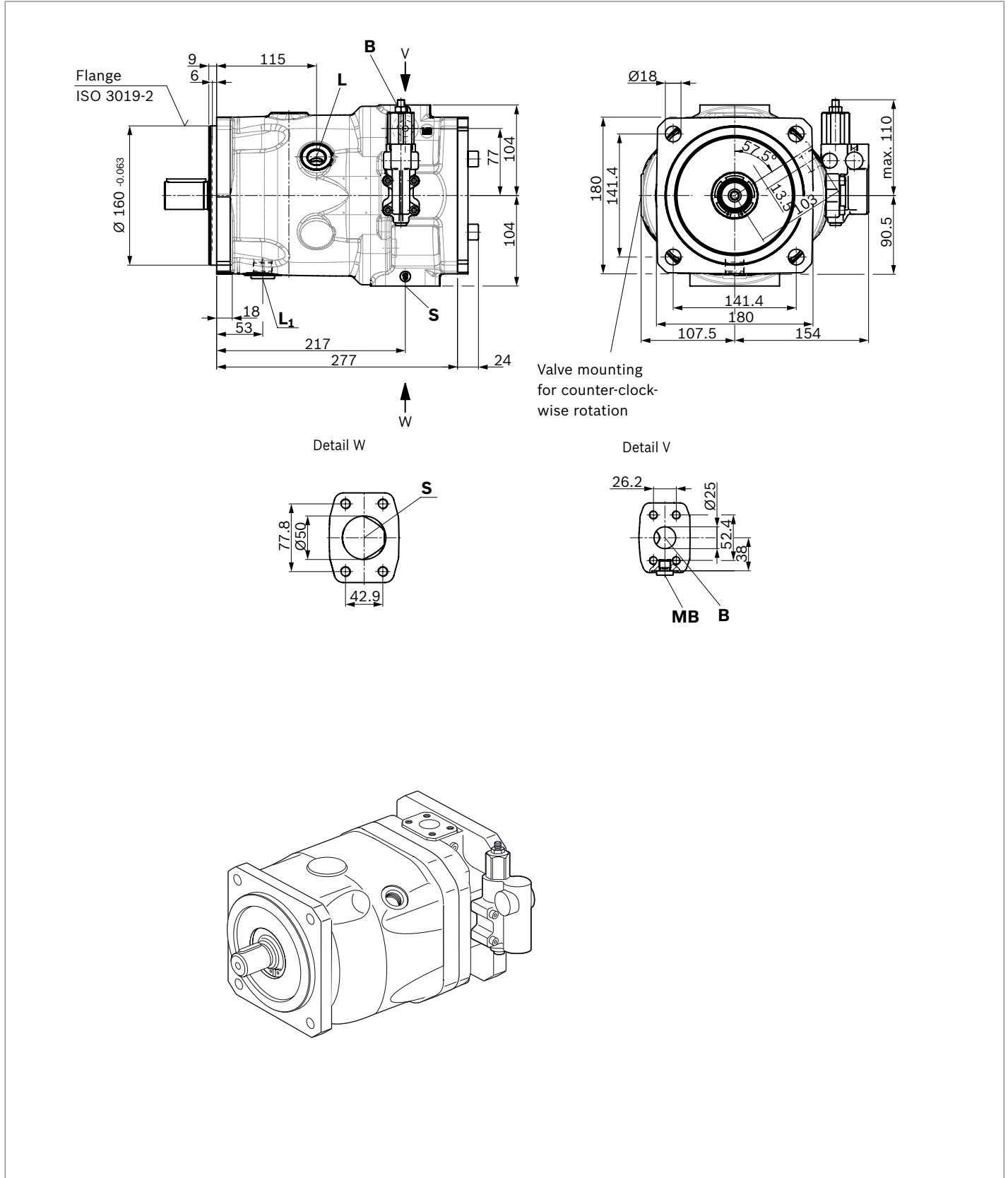

▼ **Splined shaft 1 1/4 in (SAE J744)**

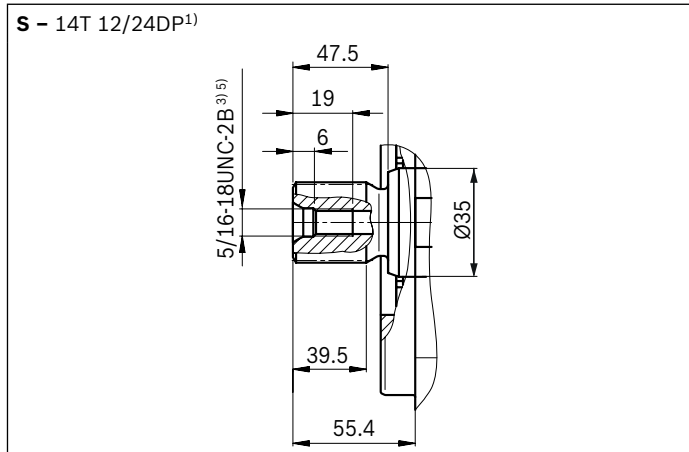

▼ **Splined shaft 1 1/4 in (SAE J744)**

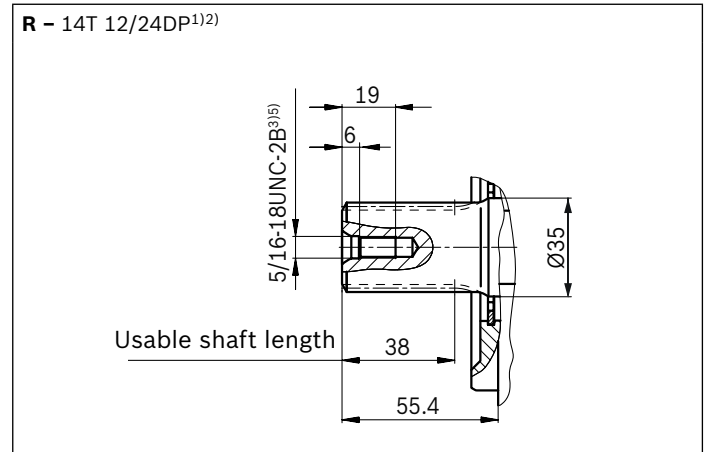

▼ **Parallel keyed shaft DIN 6885**

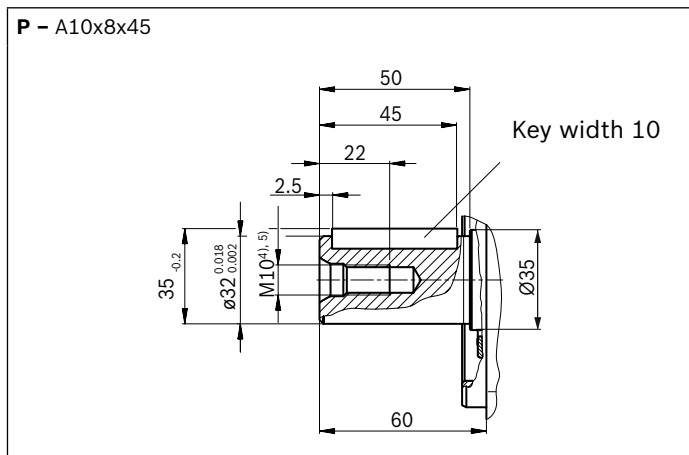

Ports	Standard	Size ⁵⁾	$p_{\max \text{ abs}}$ [bar] ⁶⁾	Condition ¹⁰⁾
B Service line port (standard pressure series) Fastening thread	SAE J518 ⁷⁾ DIN 13	1 in M10 x 1.5, 17 deep	350	O
S Suction port (standard pressure series) Fastening thread	SAE J518 ⁷⁾ DIN 13	2 in M12 x 1.75; 20 deep	10	O
L Drain port	DIN 3852 ⁸⁾	M22 x 1.5; 14 deep	2	O ⁹⁾
L₁ Drain port	DIN 3852 ⁸⁾	M22 x 1.5; 14 deep	2	X ⁹⁾
X Control pressure	DIN 3852	M14 x 1.5; 12 deep	350	O
X Pilot pressure (with DG-control)	DIN ISO 228	G 1/4 in; 12 deep	280	O
M_B Measuring pressure B	DIN 3852 ⁸⁾	G 1/4 in; 12 deep	350	X

1) Involute spline according to ANSI B92.1a, 30° pressure angle, flat root, side fit, tolerance class 5
 2) Splines according to ANSI B92.1a, run out of spline is a deviation from standard.
 3) Thread according to ASME B1.1
 4) Center bore according to DIN 332 (thread according to DIN 13)
 5) Observe the general instructions on page 47 concerning the maximum tightening torques.

6) Depending on the application, momentary pressure peaks may occur. Keep this in mind when selecting measuring devices and fittings.
 7) Metric fixing thread differing from standard
 8) The spot face can be deeper than as specified in the standard.
 9) Depending on the installation position, L or L₁ must be connected (also see installation instructions starting on page 44).
 10) O = Must be connected (plugged on delivery)
 X = Plugged (in normal operation)

▼ **DG – Two-point control, directly operated**

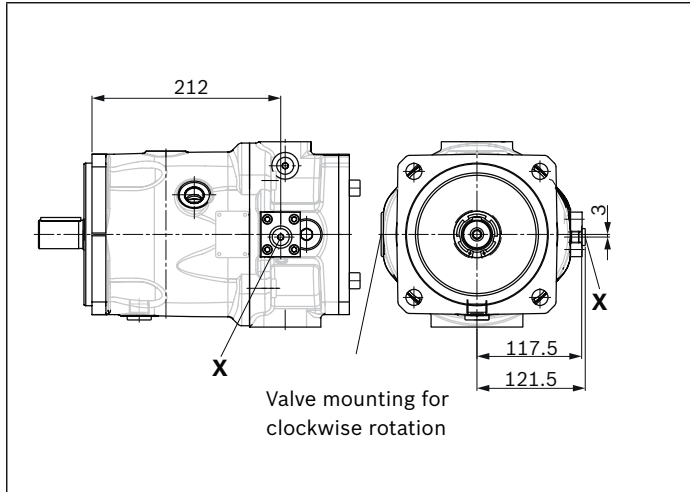

▼ **LA.DS – Pressure, flow and power control**

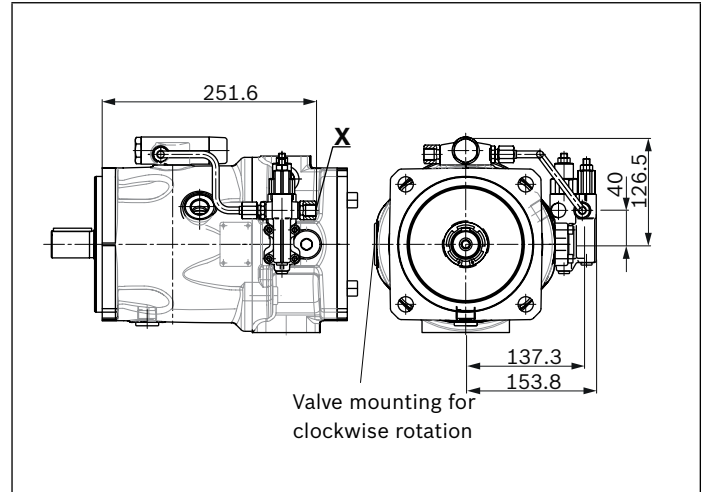

▼ **DRG – Pressure controller, remotely operated**

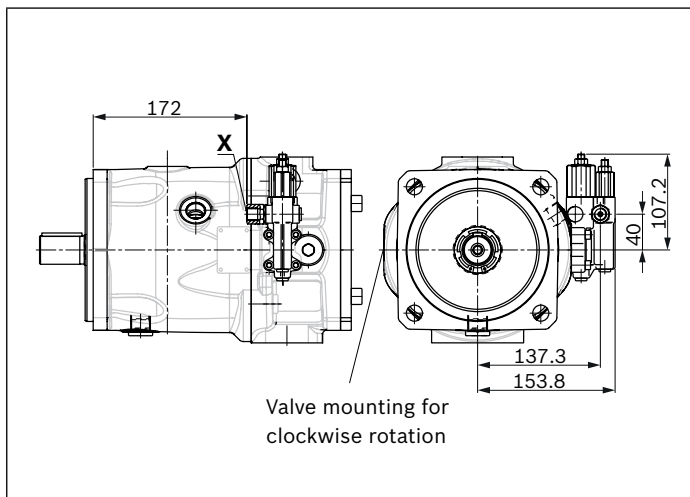

▼ **ED7./ER7. – Pressure controller, electrical**

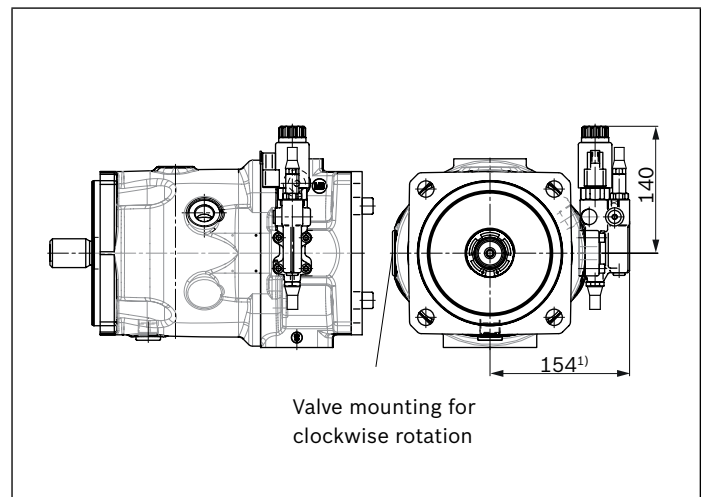

▼ **DRF/DRS – Pressure and flow controller**

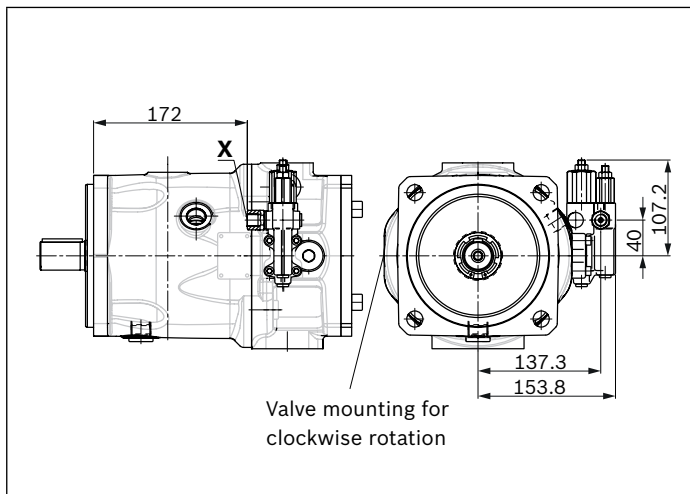

1) ER7.: 189 mm if using an intermediate plate pressure controller

Dimensions, size 100

DR – Pressure controller

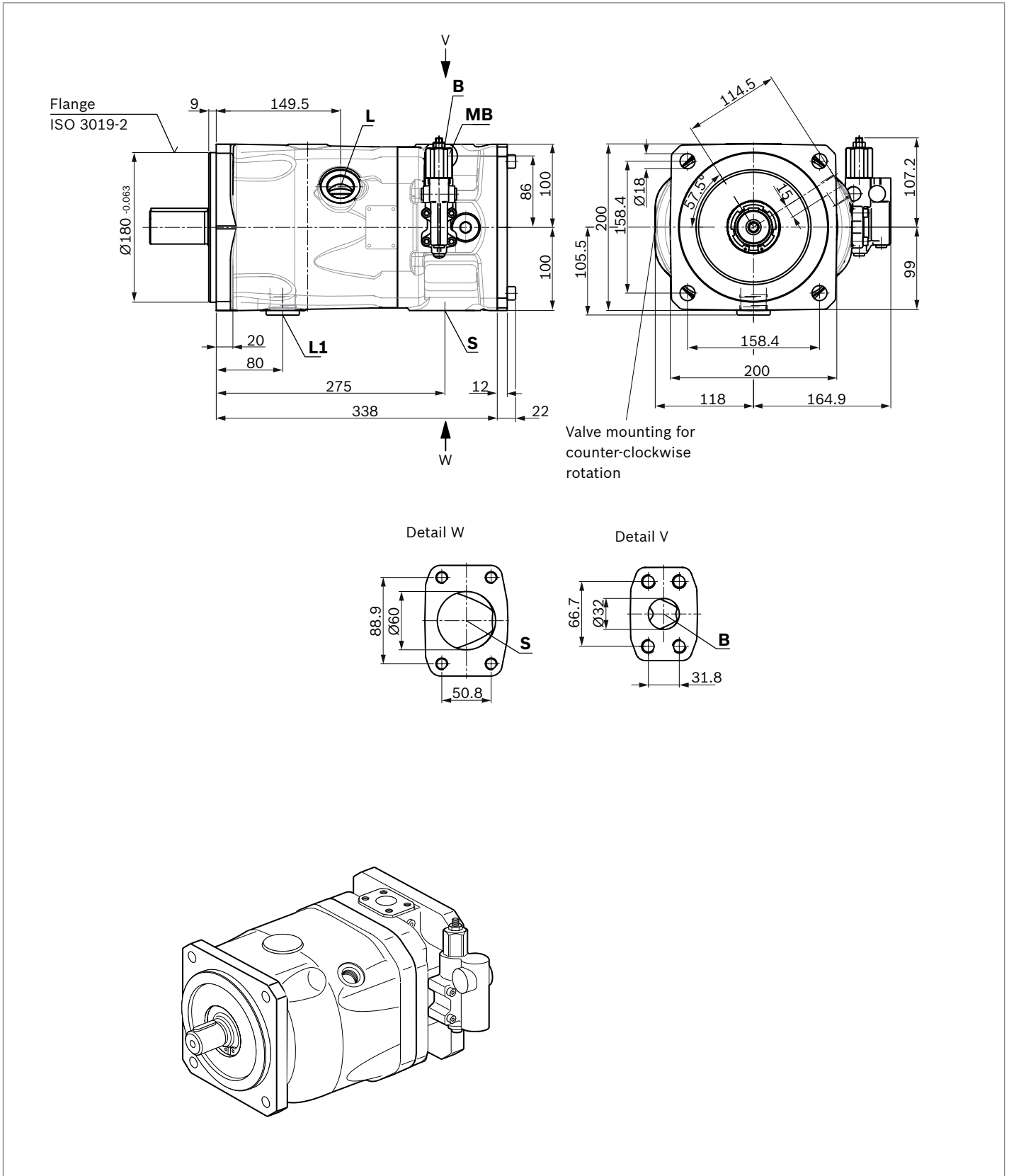

▼ **Splined shaft 1 1/2 in (SAE J744)**

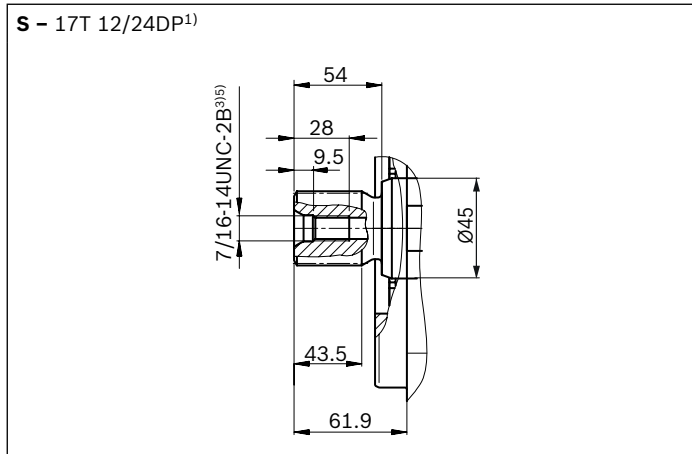

▼ **Parallel keyed shaft DIN 6885**

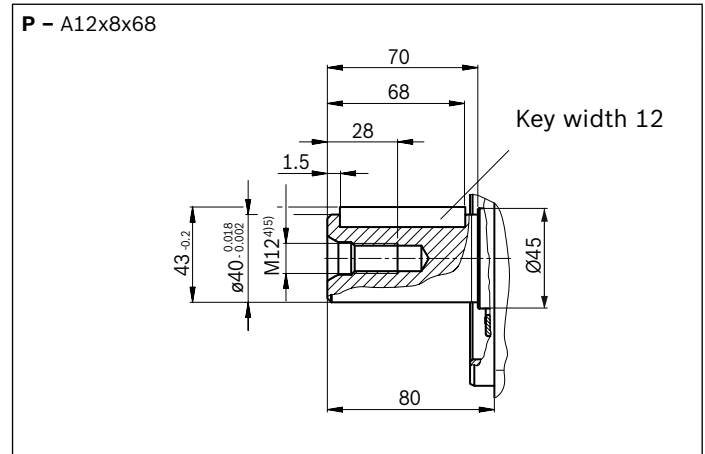

Ports		Standard	Size ⁵⁾	$p_{\max \text{ abs}}$ [bar] ⁶⁾	Condition ¹⁰⁾
B	Service line port (high-pressure line) Fastening thread	SAE J518 ⁷⁾ DIN 13	1 1/4 in M14 x 2; 19 deep	350	O
S	Suction port (standard pressure series) Fastening thread	SAE J518 ⁷⁾ DIN 13	2 1/2 in M12 x 1.75; 17 deep	10	O
L	Drain port	DIN 3852 ⁸⁾	M33 x 2. 16 deep	2	O ⁹⁾
L₁	Drain port	DIN 3852 ⁸⁾	M33 x 2. 16 deep	2	X ⁹⁾
X	Control pressure	DIN 3852	M14 x 1.5; 12 deep	350	O
X	Pilot pressure (with DG-control)	DIN ISO 228	G 1/4 in; 12 deep	280	O
M_B	Measuring pressure B	DIN 3852 ⁸⁾	G 1/4 in; 12 deep	350	X

1) Involute spline according to ANSI B92.1a, 30° pressure angle, flat root, side fit, tolerance class 5
 2) Splines according to ANSI B92.1a, run out of spline is a deviation from standard.
 3) Thread according to ASME B1.1
 4) Center bore according to DIN 332 (thread according to DIN 13)
 5) Observe the general instructions on page 47 concerning the maximum tightening torques.

6) Depending on the application, momentary pressure peaks may occur. Keep this in mind when selecting measuring devices and fittings.
 7) Metric fixing thread differing from standard
 8) The spot face can be deeper than as specified in the standard.
 9) Depending on the installation position, L or L₁ must be connected (also see installation instructions starting on page 44).
 10) O = Must be connected (plugged on delivery)
 X = Plugged (in normal operation)

▼ **DG – Two-point control, directly operated**

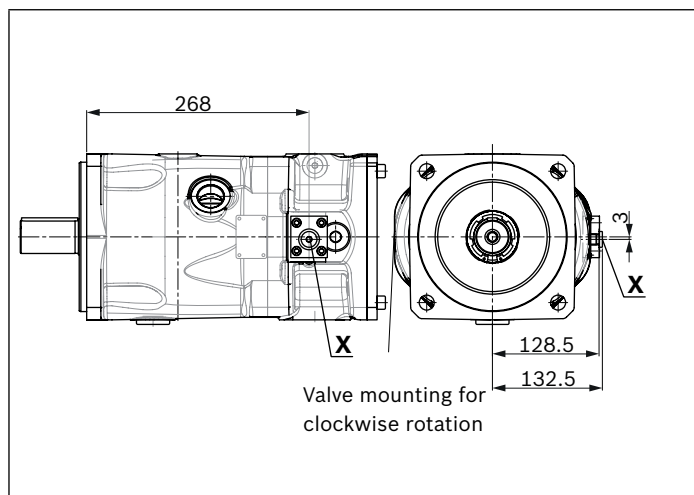

▼ **LA.DS – Pressure, flow and power control**

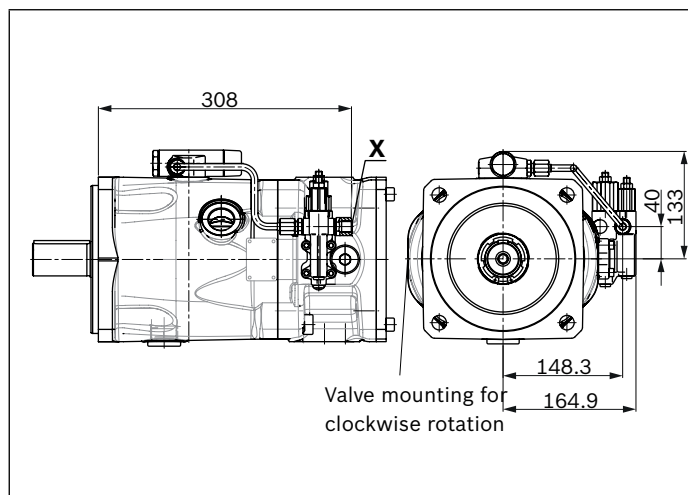

▼ **DRG – Pressure controller, remotely operated**

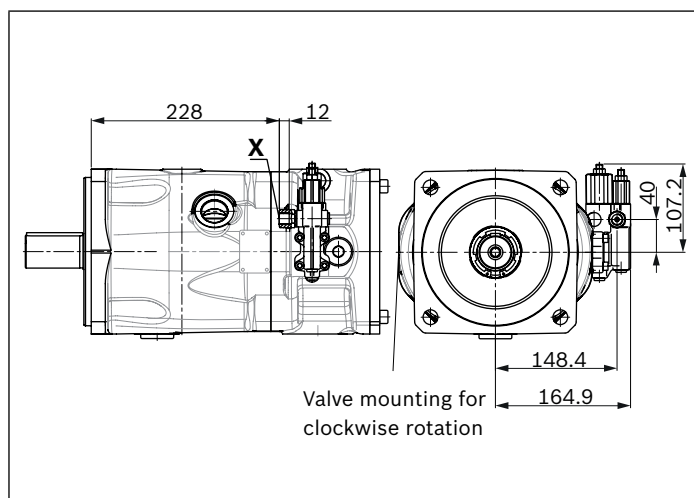

▼ **ED7./ER7. – Pressure controller, electrical**

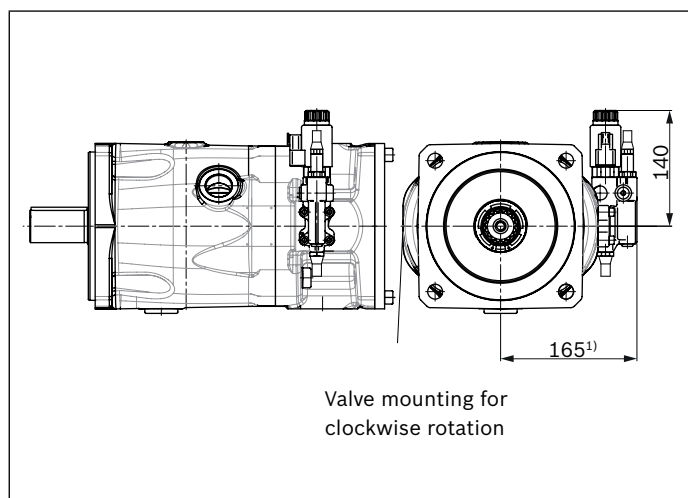

▼ **DRF/DRS – Pressure and flow controller**

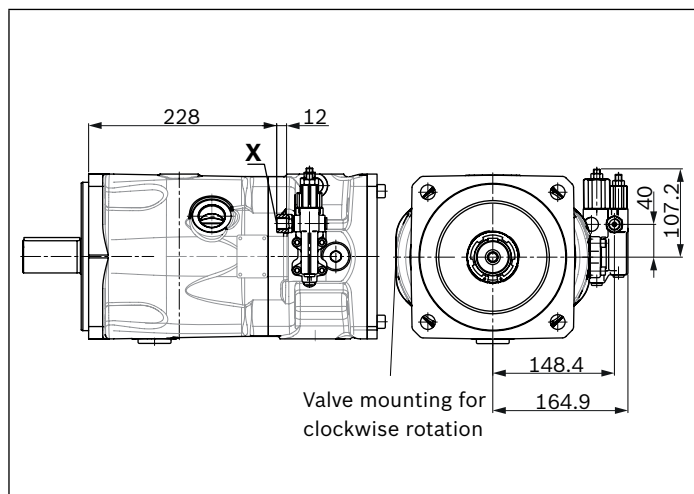

1) ER7.: 200 mm if using an intermediate plate pressure controller

Dimensions, size 140

DR – Pressure controller

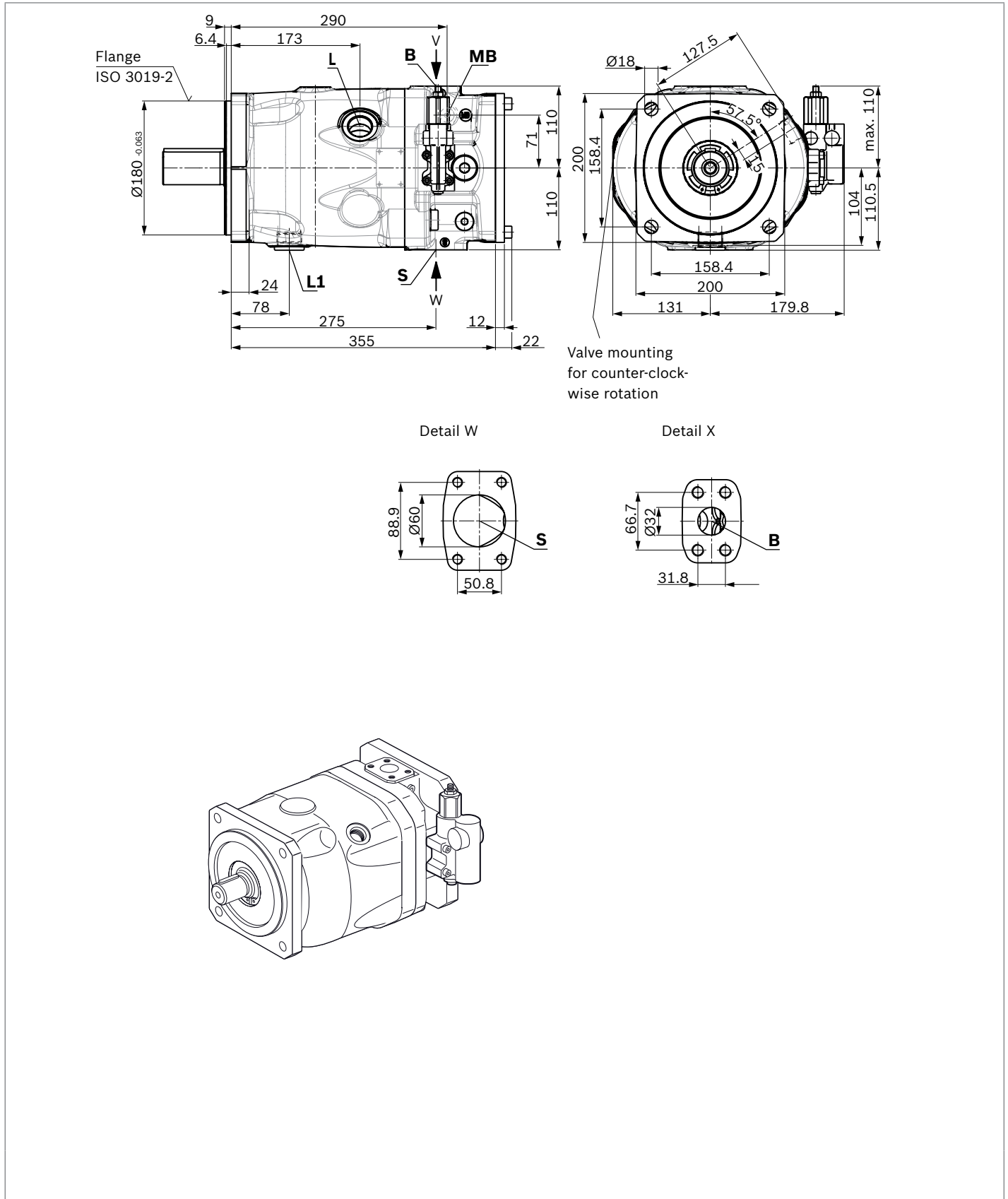

▼ Splined shaft 1 3/4 in SAE J744

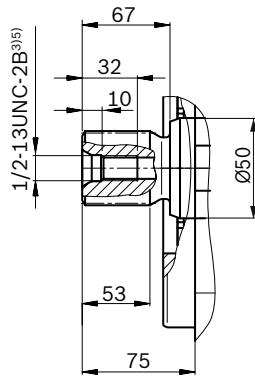
S – 13T 8/16DP¹⁾

▼ Parallel keyed shaft DIN 6885

P – A12x8x68

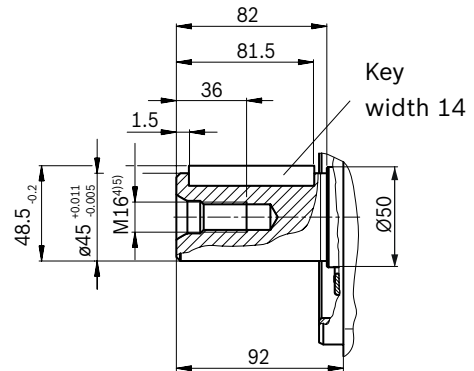

Ports	Standard	Size ⁵⁾	$p_{\max \text{ abs}}$ [bar] ⁶⁾	Condition ¹⁰⁾
B	Service line port (high-pressure line) Fastening thread	SAE J518 ⁷⁾ DIN 13	1 1/4 in M14 x 2; 19 deep	350 O
S	Suction port (standard pressure series) Fastening thread	SAE J518 ⁷⁾ DIN 13	2 1/2 in M12 x 1.75; 17 deep	10 O
L	Drain port	DIN 3852 ⁸⁾	M33 x 2. 16 deep	2 O ⁹⁾
L₁	Drain port	DIN 3852 ⁸⁾	M33 x 2. 16 deep	2 X ⁹⁾
X	Control pressure	DIN 3852	M14 x 1.5; 12 deep	350 O
X	Pilot pressure (with DG-control)	DIN ISO 228	G 1/4 in; 12 deep	280 O
M_B	Measuring pressure B	DIN 3852 ⁸⁾	G 1/4 in; 12 deep	350 X

- 1) Involute spline according to ANSI B92.1a, 30° pressure angle, flat root, side fit, tolerance class 5
- 2) Splines according to ANSI B92.1a, run out of spline is a deviation from standard.
- 3) Thread according to ASME B1.1
- 4) Center bore according to DIN 332 (thread according to DIN 13)
- 5) Observe the general instructions on page 47 concerning the maximum tightening torques.

- 6) Depending on the application, momentary pressure peaks may occur. Keep this in mind when selecting measuring devices and fittings.
- 7) Metric fixing thread differing from standard
- 8) The spot face can be deeper than as specified in the standard.
- 9) Depending on the installation position, L or L₁ must be connected (also see installation instructions starting on page 44).
- 10) O = Must be connected (plugged on delivery)
X = Plugged (in normal operation)

▼ **DG – Two-point control, directly operated**

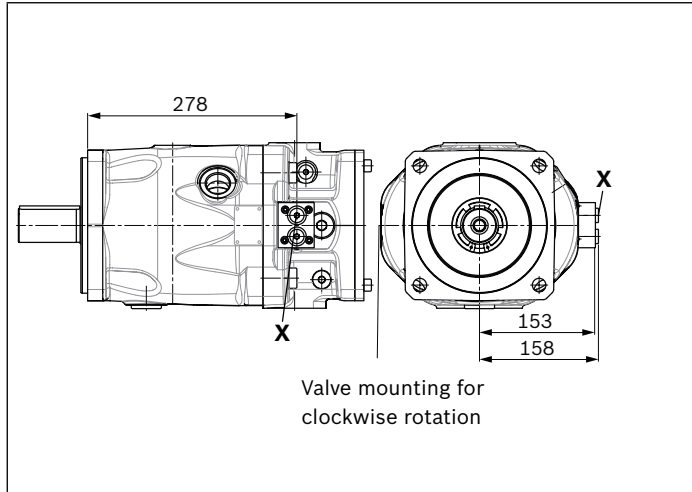

▼ **LA.DS – Pressure, flow and power control**

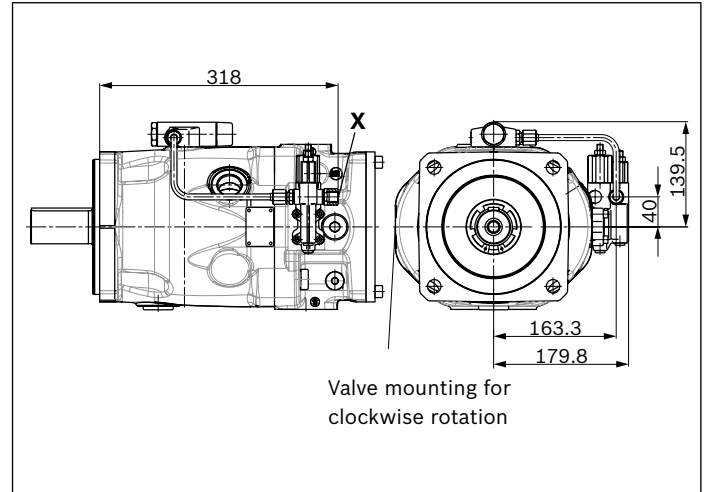

▼ **DRG – Pressure controller, remotely operated**

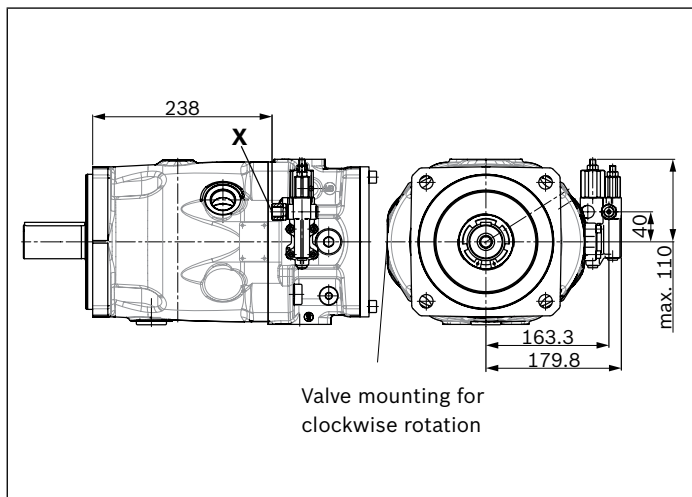

▼ **ED7./ER7. – Pressure controller, electrical**

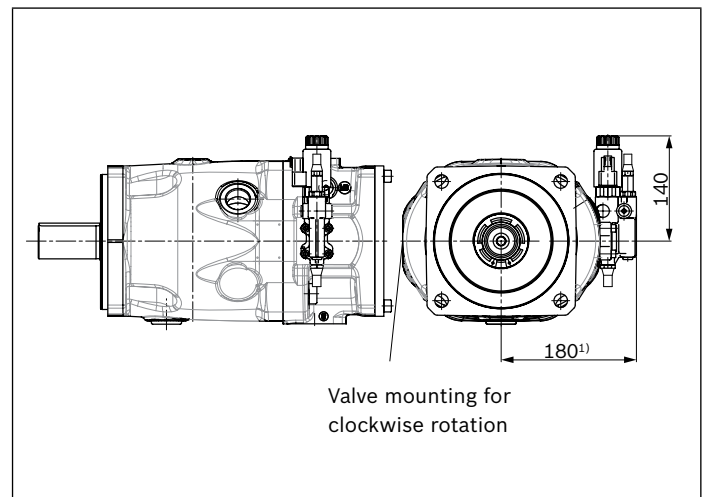

▼ **DRF/DRS – Pressure and flow controller**

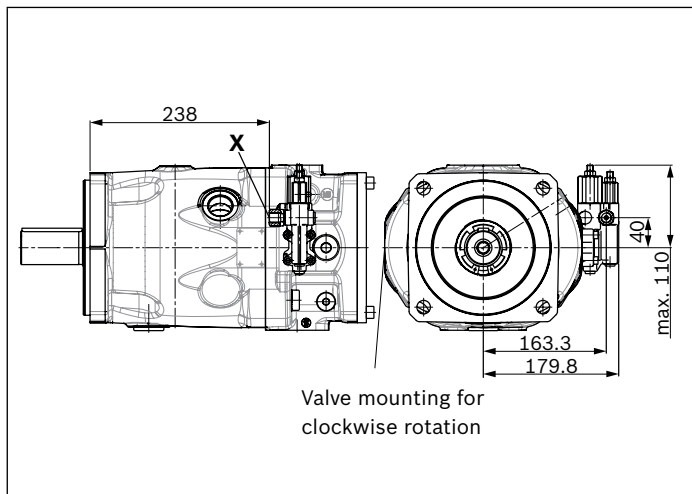

1) ER7.: 215 mm if using an intermediate plate pressure controller

Dimensions, size 180

DR – Pressure controller

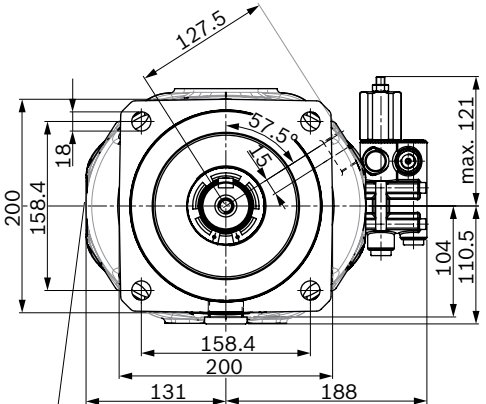
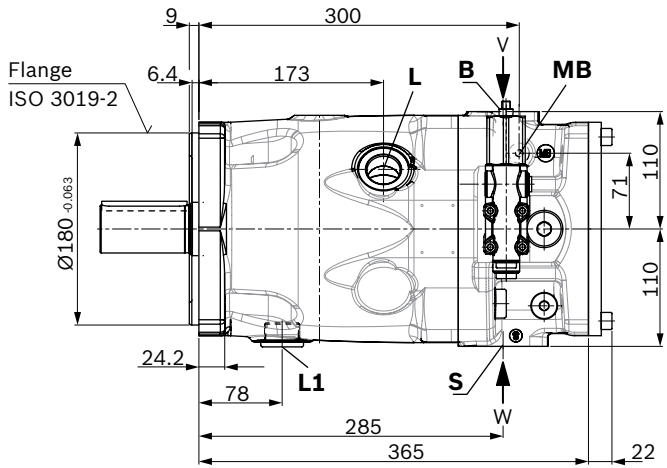

Valve mounting
 for counter-clock-
 wise rotation

Detail W

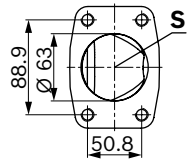

Detail X

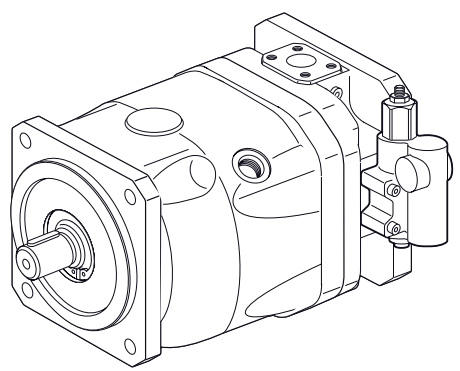
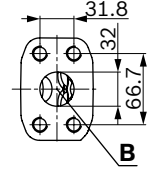

▼ **Splined shaft 1 3/4 in SAE J744**

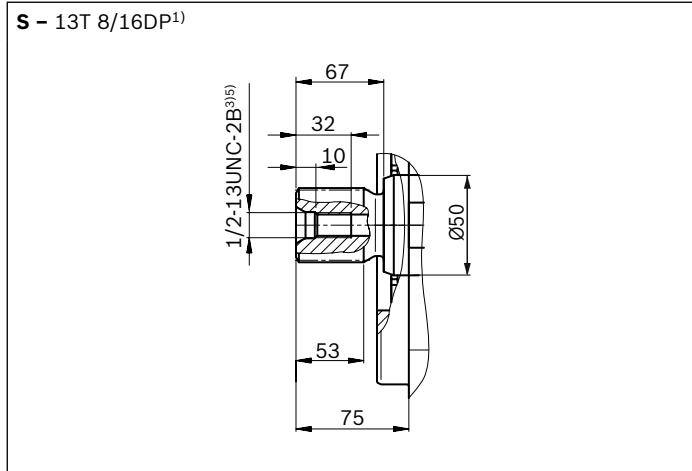

▼ **Parallel keyed shaft DIN 6885**

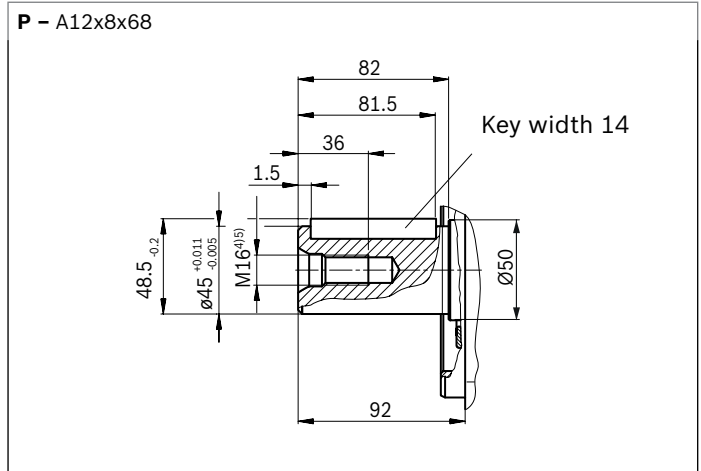

Ports		Standard	Size ⁵⁾	$p_{\max \text{ abs}}$ [bar] ⁶⁾	Condition ¹⁰⁾
B	Service line port (high-pressure line) Fastening thread	SAE J518 ⁷⁾ DIN 13	1 1/4 in M14 x 2; 19 deep	350	O
S	Suction port (standard pressure series) Fastening thread	SAE J518 ⁷⁾ DIN 13	2 1/2 in M12 x 1.75; 17 deep	10	O
L	Drain port	DIN 3852 ⁸⁾	M33 x 2. 16 deep	2	O ⁹⁾
L₁	Drain port	DIN 3852 ⁸⁾	M33 x 2. 16 deep	2	X ⁹⁾
X	Control pressure	DIN 3852	M14 x 1.5; 12 deep	350	O
X	Pilot pressure (with DG-control)	DIN ISO 228	G 1/4 in; 12 deep	280	O
M_B	Measuring pressure B	DIN 3852 ⁸⁾	G 1/4 in; 12 deep	350	X

1) Involute spline according to ANSI B92.1a, 30° pressure angle, flat root, side fit, tolerance class 5
 2) Splines according to ANSI B92.1a, run out of spline is a deviation from standard.
 3) Thread according to ASME B1.1
 4) Center bore according to DIN 332 (thread according to DIN 13)
 5) Observe the general instructions on page 47 concerning the maximum tightening torques.

6) Depending on the application, momentary pressure peaks may occur. Keep this in mind when selecting measuring devices and fittings.
 7) Metric fixing thread differing from standard
 8) The spot face can be deeper than as specified in the standard.
 9) Depending on the installation position, L or L₁ must be connected (also see installation instructions starting on page 44).
 10) O = Must be connected (plugged on delivery)
 X = Plugged (in normal operation)

▼ **DG – Two-point control, directly operated**

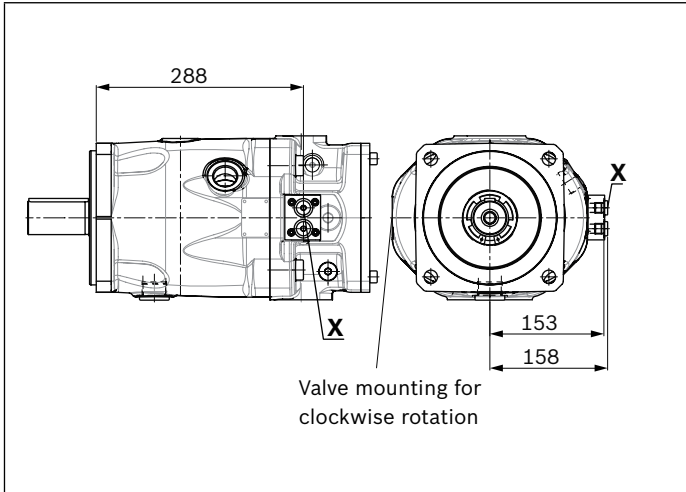

▼ **LA.DS – Pressure, flow and power control**

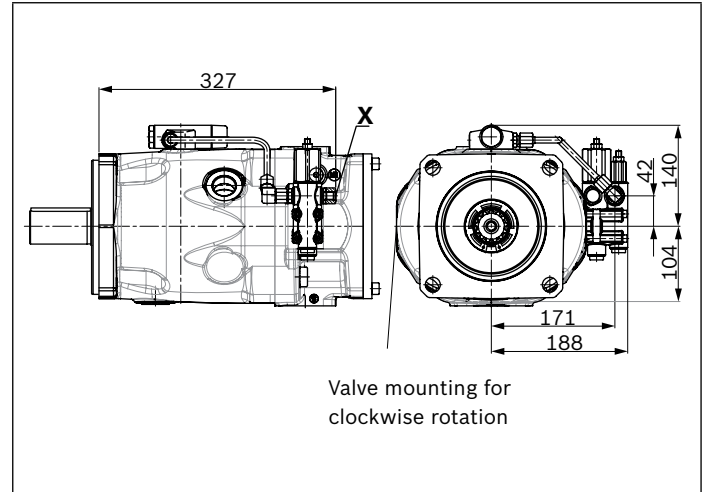

▼ **DRG – Pressure controller, remotely operated**

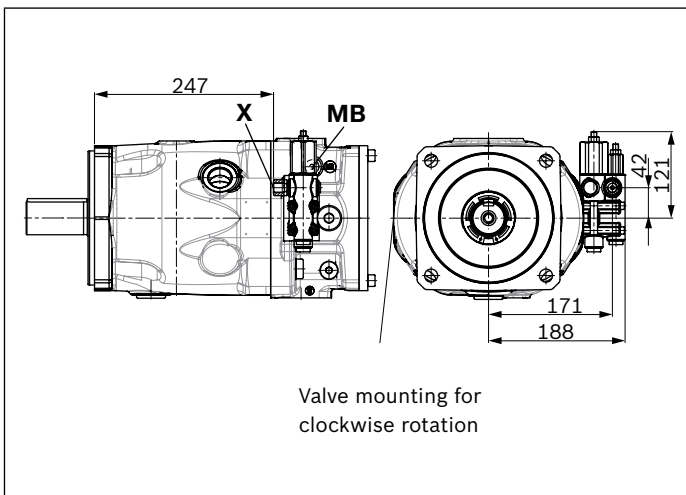

▼ **ED7./ER7. – Pressure controller, electrical**

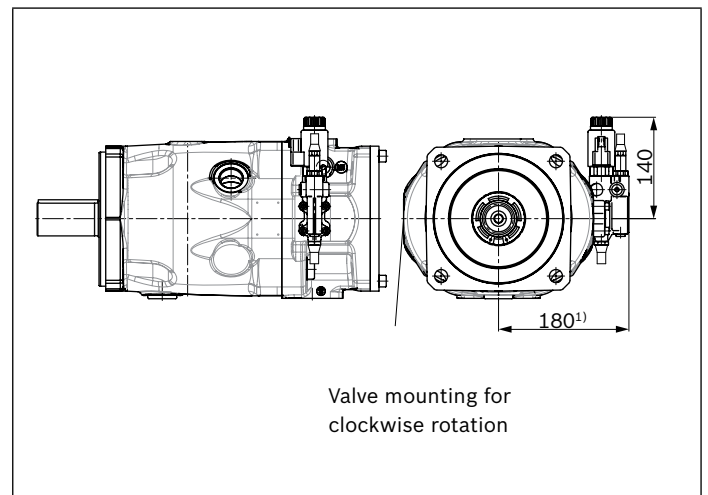

▼ **DRF/DRS – Pressure and flow controller**

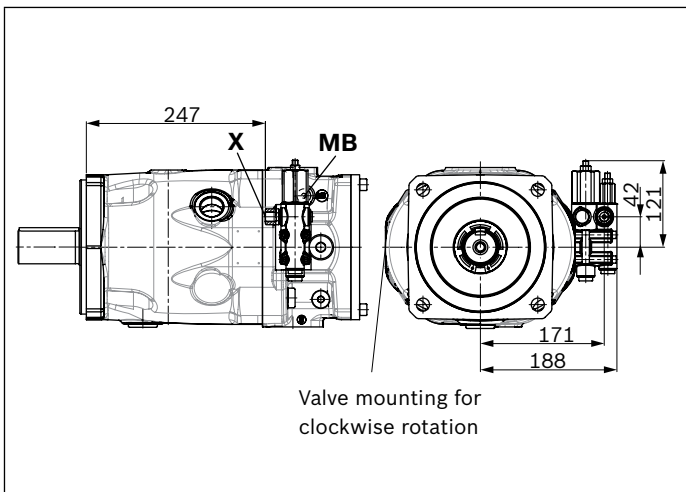

1) ER7.: 215 mm if using an intermediate plate pressure controller

Dimensions through drive

Flange ISO 3019-2 (metric)		Hub for splined shaft ¹⁾		Availability over sizes					Code
Diameter	Attachment ²⁾	Diameter		45	71	100	140	180	
80-2	⌀, ♂, ∞	3/4 in	11T 16/32DP	●	●	●	●	●	UB2
100-2	⌀, ♂, ∞	7/8 in	13T 16/32DP	●	●	●	●	●	UB3

● = Available ○ = On request

▼ 80-2

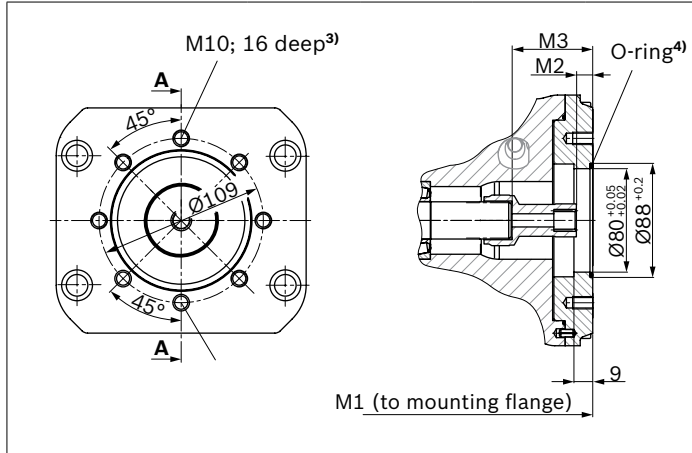

UB2 (SAE J744 16-4 (A-B))	NG	M1	M2	M3
	45	264	On request	
	71	299	21.3	40.6
	100	360	19	38.6
	140	377	19	38.6
	180	387	On request	

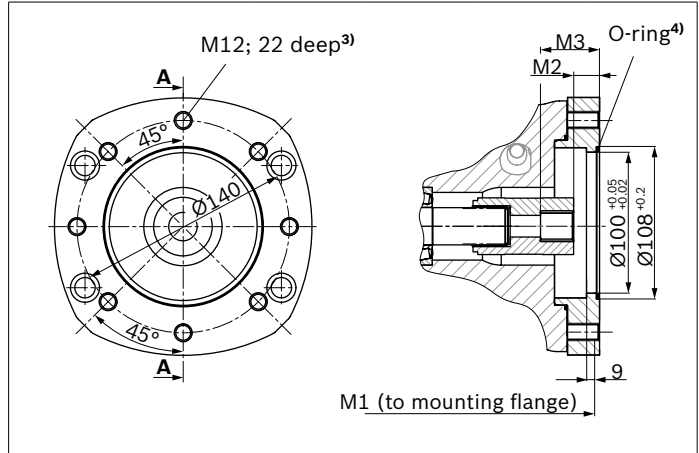

▼ 100-2



UB3 (SAE J744 22-4 (B))	NG	M1	M2	M3
	45	264	18	41.7
	71	299	20.3	44.1
	100	360	18	41.9
	140	377	18	41.6
	180	387	On request	

1) According to ANSI B92.1a, 30° pressure angle, flat root, side fit, tolerance class 5
2) Mounting bores pattern viewed from through drive with hub control at top

3) Thread according to DIN 13, observe the general instructions on page 47 for the maximum tightening torques.
4) O-ring included in the scope of supply

Flange ISO 3019-2 (metric)		Hub for splined shaft ¹⁾		Availability over sizes					Code
Diameter	Attachment ²⁾	Diameter		45	71	100	140	180	
125-4		1 in	15T 16/32DP	●	●	●	●	●	UE1
160-4		1 1/4 in	14T 12/24DP	-	●	●	●	●	UB8

● = Available ○ = On request

▼ 125-4

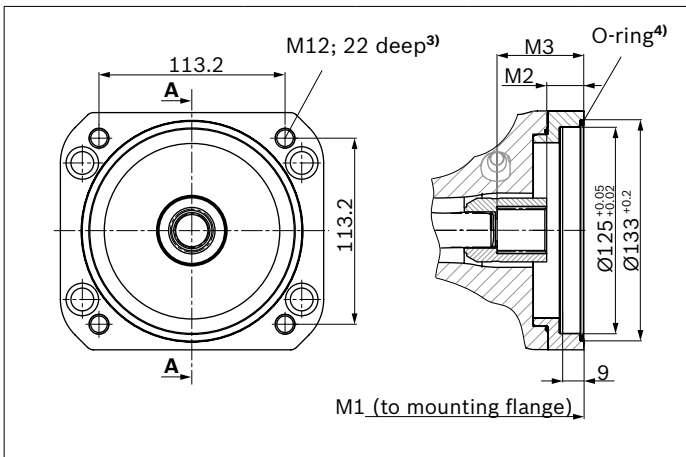

UE1 (SAE J744 25-4(B-B))	NG	M1	M2	M3
	45	264	On request	
	71	299		
	100	360	18.2	46.9
	140	377	18.5	45.9
	180	387	19.1	46.9

▼ 160-4

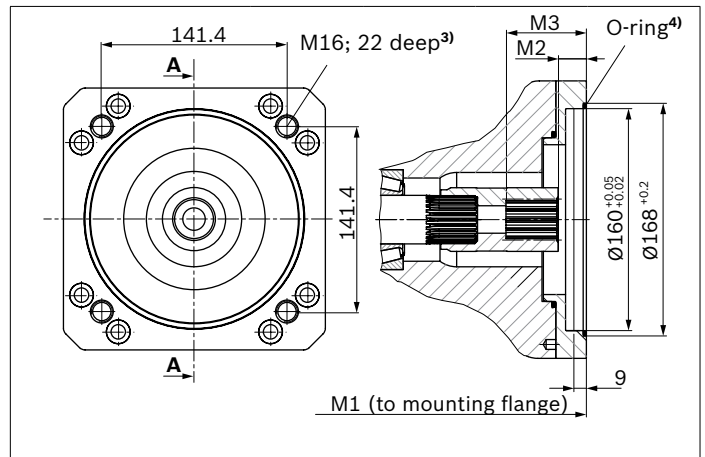

UB8 (SAE J744 32-4 (C))	NG	M1	M2	M3
	71	299	20.1	58.1
	100	360	19.8	56.4
	140	377	19.8	56.4
	180	387	20.1	56.4

1) According to ANSI B92.1a, 30° pressure angle, flat root, side fit, tolerance class 5
 2) Mounting bores pattern viewed from through drive with control at top

3) Thread according to DIN 13, observe the general instructions on page 47 for the maximum tightening torques.
 4) O-ring included in the scope of supply

Flange ISO 3019-2 (metric)		Hub for splined shaft ¹⁾		Availability over sizes					Code
Diameter	Attachment ²⁾	Diameter		45	71	100	140	180	
180-4		1 1/2 in	17T 12/24DP	-	-	•	•	•	UB9
		1 3/4 in	13T 8/16DP	-	-	-	•	•	UB7

• = Available ◦ = On request

▼ **180-4**

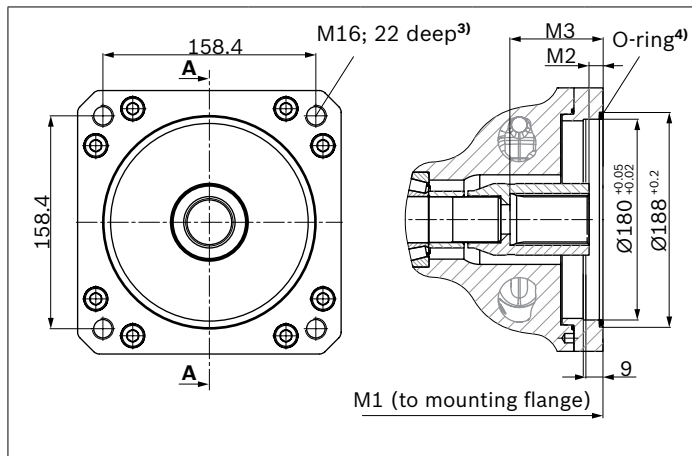

▼ **180-4**

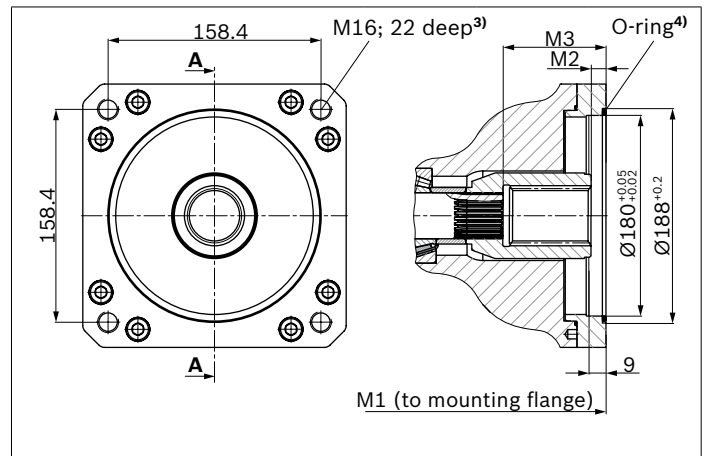

UB9 (SAE J744 38-4 (C-C))	NG	M1	M2	M3
	100	360	9	63.9
	140	377	10.2	74.9
	180	387	10.8	76

UB7 (SAE J744 44-4 (D))	NG	M1	M2	M3
	140	377	10.4	77.4
	180	387	On request	

1) According to ANSI B92.1a, 30° pressure angle, flat root, side fit, tolerance class 5
2) Mounting bores pattern viewed from through drive with control at top

3) Thread according to DIN 13, observe the general instructions on page 47 for the maximum tightening torques.
4) O-ring included in the scope of supply

Flange ISO 3019-1 (SAE J744)		Hub for splined shaft ¹⁾		Availability over sizes					Code
Diameter	Attachment ²⁾	Diameter		45	71	100	140	180	
82-2 (A)	⌀, ⌀ [∘] , ∞	5/8 in	9T 16/32DP	●	●	●	●	●	U01
	⌀, ⌀ [∘] , ∞	3/4 in	11T 16/32DP	●	●	●	●	●	U52

● = Available ∘ = On request

▼ **82-2 (A)**

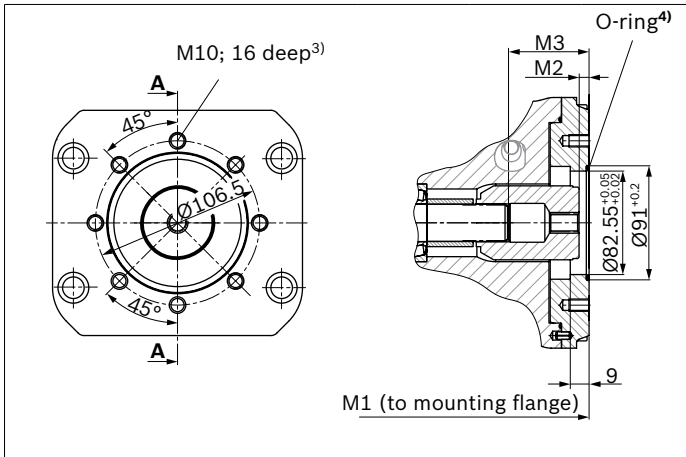

▼ **82-2 (A)**

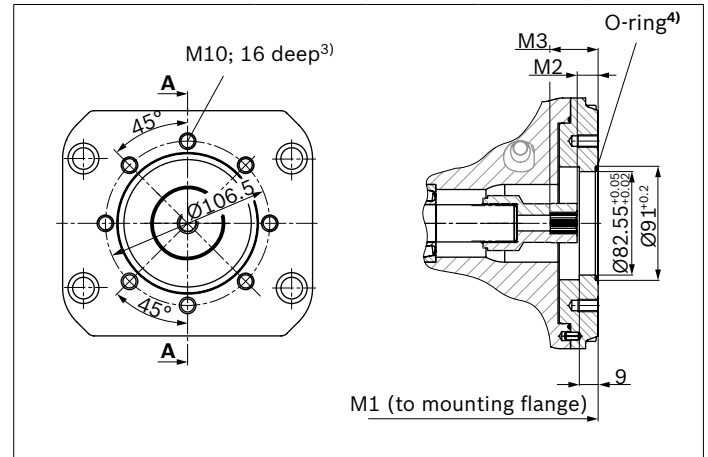

U01 (SAE J744 16-4 (A))	NG	M1	M2	M3
	45	264	On request	
	71	299	9.3	61.3
	100	360	10.5	65
	140	377	On request	
	180	387		

U52 SAE J744 19-4 (A-B))	NG	M1	M2	M3
	45	264	18.6	38.7
	71	299	20.7	41.4
	100	360	17	38
	140	377	19	38.6
	180	387	On request	

1) According to ANSI B92.1a, 30° pressure angle, flat root, side fit, tolerance class 5
2) Mounting bores pattern viewed from through drive with control at top

3) Thread according to DIN 13, observe the general instructions on page 47 for the maximum tightening torques.
4) O-ring included in the scope of supply

Flange ISO 3019-2 (metric)		Hub for splined shaft ¹⁾		Availability over sizes					Code
Diameter	Attachment ²⁾	Diameter		45	71	100	140	180	
101-2 (B)	⌀, ⌀, ∞	7/8 in	13T 16/32DP	•	•	•	•	•	U68
	⌀, ⌀, ∞	1 in	15T 16/32DP	•	•	•	•	•	U04

• = Available ∘ = On request

▼ 101-2

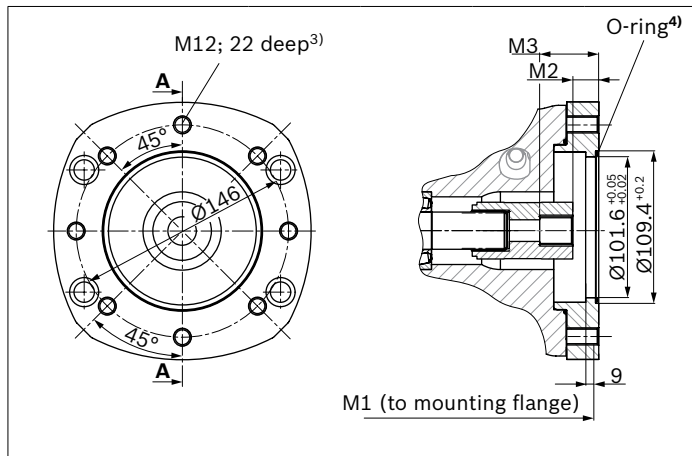

▼ 101-2

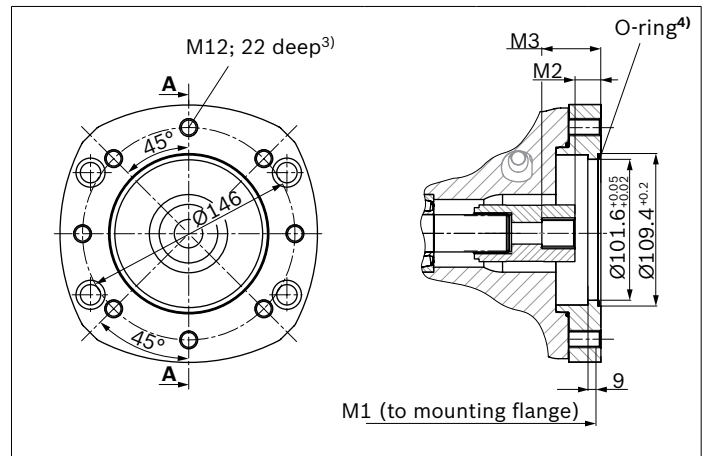

U68 (SAE J744 22-4) (B))	NG	M1	M2	M3
	45	264	18.2	41.5
	71	299	19.7	44.1
	100	360	17.4	41.3
	140	377	17.4	41.6
	180	387	18.6	42.4

U04 SAE J744 25-4 (B-B))	NG	M1	M2	M3
	45	264	On request	
	71	299	20.8	49.1
	100	360	17.6	46.6
	140	377	17.9	46.3
	180	387	On request	

1) Hub for splined shaft according to ANSI B92.1a, 30° pressure angle, flat root, side fit, tolerance class 5
2) Mounting bores pattern viewed from through drive with control at top

3) Thread according to DIN 13, observe the general instructions on page 47 for the maximum tightening torques.
4) O-ring included in the scope of supply

Flange ISO 3019-1 (SAE J744)		Splined shaft ¹⁾		Availability over sizes					Code
Diameter	Attachment ²⁾	Diameter		45	71	100	140	180	
127-4 (C)	⌘	1 in	15T 16/32DP	●	●	●	●	●	UE2
		1 1/4 in	14T 12/24DP	-	●	●	●	●	U15
127-2 (C)	⌘, ⌘ ^o , ⌘ ^{oo}	1 1/2 in	17T 12/24DP	-	-	●	●	●	U24

● = Available ○ = On request

▼ 127-4 (C)

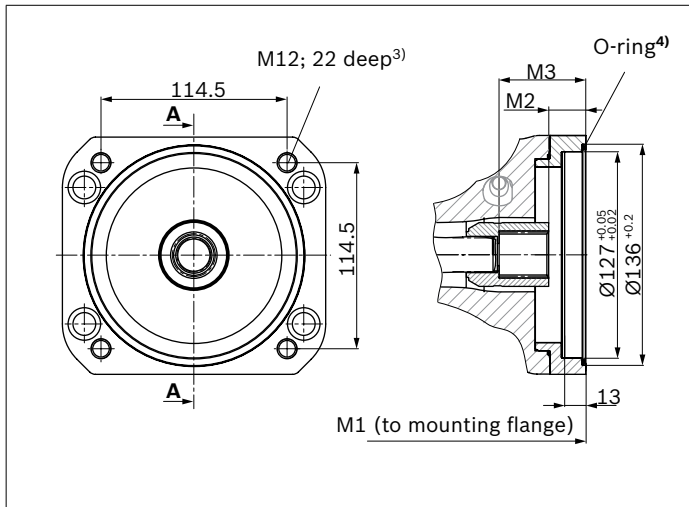

▼ 127-2 (C)

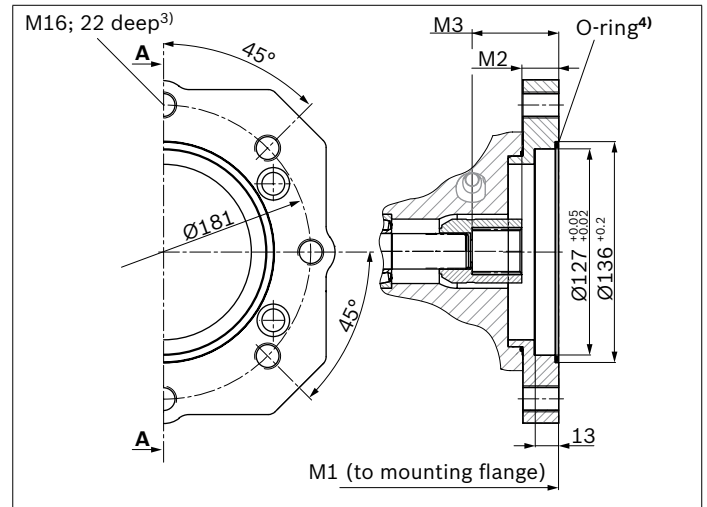

UE2 127-4 (C)	NG	M1	M2	M3
	45	264	18.7	46.6
	71	299	On request	
	100	360		
	140	377		
	180	387		

U24 127-2 (C)	NG	M1	M2	M3
	100	360	21.5	62.3
	140	377	10.5	62.3
	180	387	9.9	62.3

U15 127-4 (C)	NG	M1	M2	M3
	71	299	21.8	58.1
	100	360	On request	
	140	377		
	180	387	20	57

1) Hub for splined shaft according to ANSI B92.1a, 30° pressure angle, flat root, side fit, tolerance class 5
2) Mounting bores pattern viewed from through drive with control at top

3) Thread according to DIN 13, observe the general instructions on page 47 for the maximum tightening torques.
4) O-ring included in the scope of supply

Flange ISO 3019-1 (SAE J744)		Splined shaft ¹⁾		Availability over sizes					Code
Diameter	Attachment ²⁾	Diameter		45	71	100	140	180	
152-4 (C)		1 1/2 in	17T 12/24DP	-	-	●	●	●	U96
		1 3/4 in	13T 8/16DP	-	-	-	●	●	U17

● = Available ○ = On request

▼ **152-4 (C)**

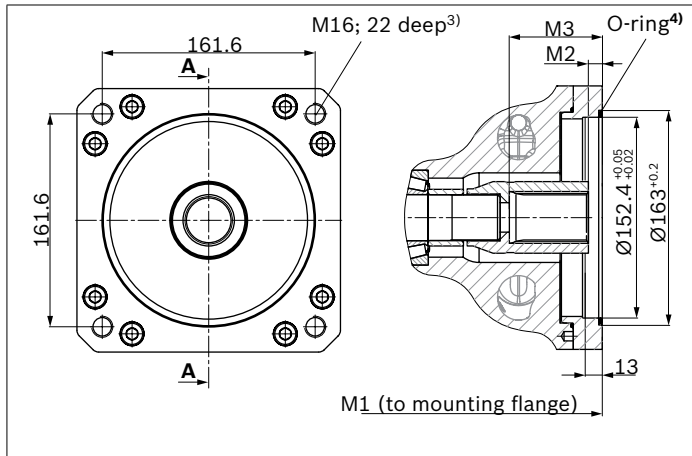

▼ **152-4 (C)**

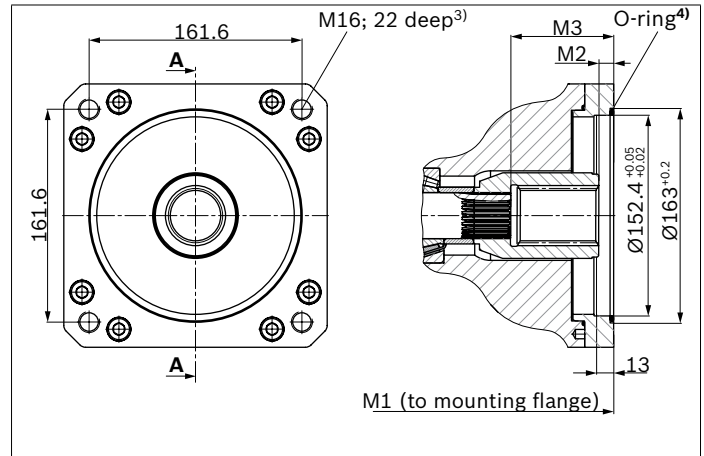

U96	NG	M1	M2	M3
152-4 (D)				
	100	360	On request	
	140	377		
	180	387		

U17	NG	M1	M2	M3
152-4 (D)				
	140	377	11	77.5
	180	387	11	77.5

1) Hub for splined shaft according to ANSI B92.1a, 30° pressure angle, flat root, side fit, tolerance class 5
2) Mounting bores pattern viewed from through drive with control at top

3) Thread according to DIN 13, observe the general instructions on page 47 for the maximum tightening torques.
4) O-ring included in the scope of supply

Overview of attachment options

Through drive			Attachment options – 2nd pump			
Flange (ISO) ISO 3019-2	Hub for splined shaft	Short code	A10VSO/32 NG (shaft)	A10VSO/31 NG (shaft)	A10VO/52 and 53 NG (shaft)	Gear pump
80-2	3/4 in	UB2	–	18 (S, R)	10 (S, R)	PGZ
100-2	7/8 in	UB3	–	28 (S, R)	–	PGZ
125-4	1 in	UE1	45 (S, R)	–	–	–
160-4	1 1/4 in	UB8	71 (S, R)	–	–	–
180-4	1 1/2 in	UB9	100 (S)	–	–	–
	1 3/4 in	UB7	140, 180 (S)	–	–	–
Flange (SAE) ISO 3019-1	Hub for splined shaft	Short code	A10VSO/32 NG (shaft)	A10VSO/31 NG (shaft)	A10VO/52 and 53 NG (shaft)	Gear pump
82-2 (A)	5/8 in	U01	–	–	–	AZPF, PGH2
	3/4 in	U52	–	18 (S, R)	10 (S, R)	–
101-2 (B)	7/8 in	U68	–	28 (S, R)	–	AZPN, AZPG
	1 in	U04	–	–	–	PGH4
127-4 (C)	1 in	UE2	45 (S, R)	–	–	–
127-4 (C)	1 1/4 in	U15	71 (S)	–	–	–
127-2 (C)	1 1/2 in	U24	100 (S)	–	–	PGH5
152-4 (D)	1 1/2 in	U96	100 (S)	–	–	–
	1 3/4 in	U17	140, 180 (S)	–	–	–

Combination pumps A10VSO + A10VSO

By using combination pumps, it is possible to have independent circuits without the need for splitter gearboxes. When ordering combination pumps, the type designations of the 1st and 2nd pump must be linked by a “+”.

Order example:

A10VSO100DR/32R-VPB32UB8+

A10VSO71DRF/32R-VSB22U00

It is permissible to use a combination of two single pumps of the same nominal size (tandem pump) considering a dynamic mass acceleration of maximum 10 g (= 98.1 m/s²) without additional support brackets.

For combination pumps consisting of more than two pumps, the mounting flange must be rated for the permissible mass torque (please consult us).

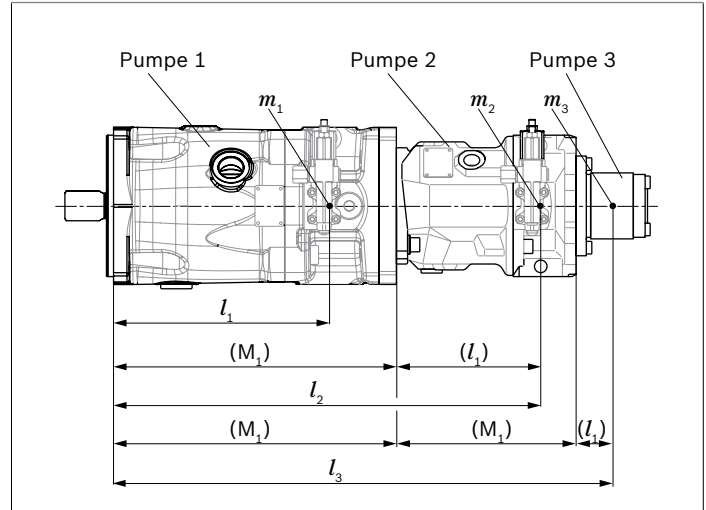

m_1, m_2, m_3	Weight of pump	[kg]
l_1, l_2, l_3	Distance, center of gravity	[mm]
$T_m = (m_1 \cdot l_1 + m_2 \cdot l_2 + m_3 \cdot l_3) \cdot \frac{1}{102} \quad [\text{Nm}]$		

Calculation for multiple pumps

- l_1 = Distance, center of gravity, front pump
(value from “Permissible mass moment of inertia” table)
- l_2 = Dimension “M1” from through drive drawings
(page 34 to 40) + l_1 of the 2nd pump
- l_3 = Dimension “M1” from through drive drawings
(page 34 to 40) of the 1st pump + “M1” of the 2nd pump + l_1 of the 3rd pump

Permissible mass moment of inertia

NG			45	71	100	140	180
static	T_m	Nm	1370	3000	4500	4500	4500
dynamic at 10 g (98.1 m/s ²)	T_m	Nm	137	3,00	450	450	450
Mass	m	kg	30	47	69	73	78
Distance, center of gravity	l_1	mm	130	142	169	172	196

Please also pay attention to the installation information on page 46.

Connector for solenoids

HIRSCHMANN DIN EN 175 301-803-A /ISO 4400

without bidirectional suppressor diode _____H

There is the following type of protection with mounted mating connector:

- ▶ IP65 (DIN/EN 60529)

The seal ring in the cable fitting is suitable for lines of diameter 4.5 mm to 10 mm.

The line connector box is not included in the scope of supply.

This can be supplied by Bosch Rexroth on request.

Bosch Rexroth material number: R902602623

Changing plug position

If necessary, you can change the connector orientation by turning the solenoid housing.

To do this, proceed as follows:

- ▶ Loosen the mounting nut **(1)** of the solenoid. To do this, turn the mounting nut **(1)** one turn counter-clockwise.
- ▶ Turn the solenoid body **(2)** to the desired orientation.
- ▶ Retighten the mounting nut.
Tightening torque: 5^{+1} Nm.
(WAF 26, 12-sided DIN 3124)

On delivery, the position of the connector may differ from that shown in the brochure or drawing.

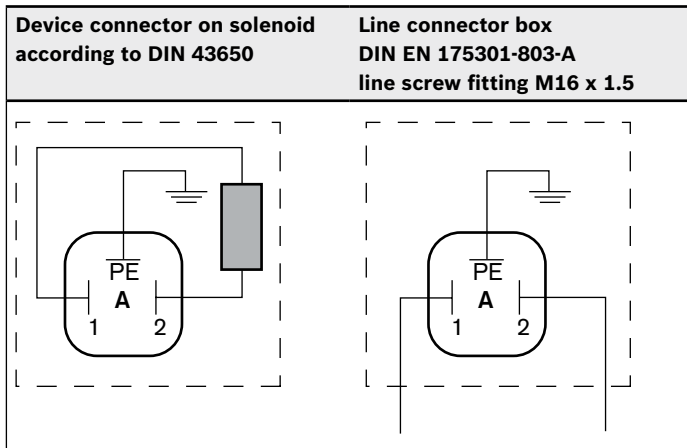
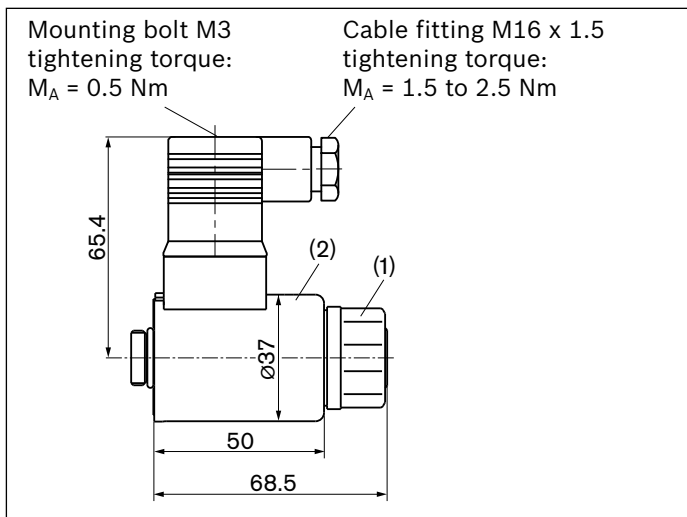

Electronic controls

Control	Electronics function	Electronics	Further information
Electric pressure control	Controlled power outlet	VT 2000 ¹⁾	analog 29904
		VT 11029 ¹⁾	analog 29741
		VT 11030 ¹⁾	

1) only 24 V nominal voltage

Installation instructions

General

The axial piston unit must be filled with hydraulic fluid and air bled during commissioning and operation. This must also be considered with a long-term standstill.

Particularly with the “drive shaft up/down” installation position, filling and air bleeding must be carried out completely as there is, for example, a danger of dry running.

The drain in the pump housing must be discharged to the reservoir via the highest available drain port (**L**, **L₁**).

If a shared drain line is used for several units, make sure that the relevant case pressure is not exceeded. The shared drain line must be dimensioned to ensure that the maximum permissible case pressure of all connected units is not exceeded in any operational circumstances, particularly at cold start. If this is not possible, separate drain lines must be laid if necessary.

To achieve favorable noise values, decouple all connecting lines using elastic elements and avoid above-reservoir installation.

In all operating conditions, the suction lines and the drain lines must flow into the reservoir below the minimum fluid level. The permissible suction height h_s results from the overall loss of pressure. However, it must not be higher than $h_{s\ max} = 800\text{ mm}$. The minimum suction pressure at port **S** (see the technical data on page 6 and 8) must not be fallen short of during operation and at cold starting either. When designing the reservoir, ensure that there is sufficient distance between the suction line and the drain line. This prevents the heated, return flow from being drawn directly back into the suction line.

Key and assembly note

Key	
L (F)	Filling/air bleeding
S	Suction port
L₁	Tank port
SB	Baffle (baffle plate)
$h_{t\ min}$	Minimum required immersion depth (200 mm)
h_{min}	Minimum required spacing to reservoir bottom (100 mm)
$h_{ES\ min}$	Minimum necessary height needed to protect the axial piston unit from draining (25 mm)
$h_{s\ max}$	Maximum permissible suction height (800 mm)

1) Because complete air bleeding and filling are not possible in this position, the pump should be air bled and filled in a horizontal position before installation.

Installation position

See the following examples **1** to **9**.

Additional installation positions are available upon request.
Recommended installation position: **1** and **3**

Below-reservoir installation (standard)

Below-reservoir installation means that the axial piston unit is installed outside of the reservoir below the minimum hydraulic fluid level.

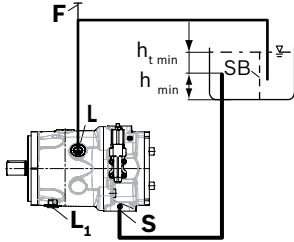
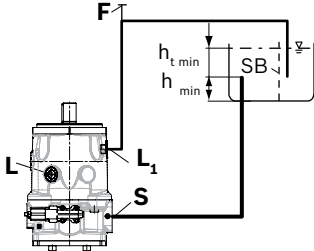
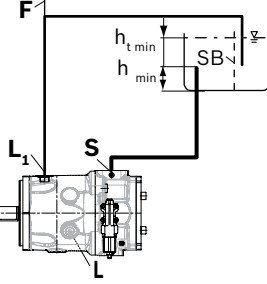
Installation position	Air bleeding	Filling
1	F	F (L)
		
2 ¹⁾	F	F (L₁)
		
3	F	F (L₁)
		

Note

Port **F** is part of the external piping and must be provided by the customer to make filling and air bleeding easier.

Above-reservoir installation

Above-reservoir installation means that the axial piston unit is installed above the minimum fluid level of the reservoir. To prevent the axial piston unit from draining in position 5, the height difference $h_{ES\ min}$ must be at least 25 mm. Observe the maximum permissible suction height $h_{S\ max} = 800\ mm$.

Installation position	Air bleeding	Filling
<p>4</p>	F	F (L)
<p>5¹⁾</p>	F	F (L₁)
<p>6</p>	F	F (L₁)

A check valve in the case drain line is only permissible in individual cases. Consult us for approval.

1) Because complete air bleeding and filling are not possible in this position, the pump should be air bled and filled in a horizontal position before installation.

Inside-reservoir installation

Inside-reservoir installation is when the axial piston unit is installed in the reservoir below the minimum fluid level. The axial piston unit is completely below the hydraulic fluid. If the minimum fluid level is equal to or below the upper edge of the pump, see chapter “Above-reservoir installation”. Axial piston units with electric components (e.g. electric controls, sensors) must not be installed in a reservoir below the fluid level.

Installation position	Air bleeding	Filling
<p>7</p>	automatically due to the position below the hydraulic fluid level	Automatically via the open port L or L ₁ due to the position under the hydraulic fluid level
<p>8</p>		
<p>9¹⁾</p>		

For key, see page 44.

Assembly note

Due to the compact design of the casing, socket-head screws with a hexagon socket must be used to attach the axial piston pump. Please observe the maximum permissible surface pressure according to VDI 2230.

Apart from this, you should take into account the information regarding tightening torques on page 47.

Project planning notes

- ▶ The A10VSO axial piston variable pump is designed to be used in open circuit.
- ▶ The project planning, installation and commissioning of the axial piston unit require the involvement of qualified skilled personnel.
- ▶ Before using the axial piston unit, please read the corresponding instruction manual completely and thoroughly. If necessary, request it from Bosch Rexroth.
- ▶ Before finalizing your design, request a binding installation drawing.
- ▶ The specified data and notes must be observed.
- ▶ Depending on the operating condition of the axial piston unit (operating pressure, fluid temperature), the characteristic curve may shift.
- ▶ Preservation: Our axial piston units are supplied as standard with preservative protection for a maximum of 12 months. If longer preservative protection is required (maximum 24 months), please specify this in plain text when placing your order. The preservation times apply under optimal storage conditions, details of these conditions can be found in the data sheet 90312 or the instruction manual.
- ▶ Not all variants of the product are approved for use in safety functions according to ISO 13849. Please consult the responsible contact person at Bosch Rexroth if you require reliability parameters (e.g. $MTTF_d$) for functional safety.
- ▶ Depending on the type of control used, electromagnetic effects can be produced when using solenoids. When a direct current is applied, solenoids do not cause electromagnetic interference nor is their operation impaired by electromagnetic interference. Other behavior can result when a modulated direct current (e.g. PWM signal) is applied. Potential electromagnetic interference for persons (e.g. persons with a pacemaker) and other components must be tested by the machine manufacturer.
- ▶ Pressure controllers are not protection against overpressure. A pressure relief valve is to be provided for the hydraulic system.
- ▶ Service line ports:
 - The ports and fastening threads are designed for the specified maximum pressure. The machine or system manufacturer must ensure that the connecting elements and lines correspond to the specified operating conditions (pressure, flow, hydraulic fluid, temperature) with the necessary safety factors.
 - The service line ports and function ports can only be used to accommodate hydraulic lines.

Safety instructions

- ▶ During and shortly after operation, there is a risk of burning on the axial piston unit and especially on the solenoids. Take appropriate safety measures (e.g. by wearing protective clothing).
- ▶ Moving parts in control and regulation systems (e.g. valve spools) may in certain circumstances become stuck in an undefined position due to contamination (e.g. contaminated hydraulic fluid, abrasion or residual dirt from components). As a result, the hydraulic fluid flow or build-up of torque of the axial piston unit will no longer respond correctly to the operator's commands. Even the use of different filter cartridges (external or internal inlet filter) will not rule out a fault but merely reduce the risk. The machine/system manufacturer must test whether remedial measures are needed on the machine for the application concerned in order to set the consumer being driven to a safe position (e.g. safe stop) and if necessary to ensure it is properly implemented.

Bosch Rexroth AG

Mobile Applications
An den Kelterwiesen 14
72160 Horb a.N., Germany
Tel. +49 7451 92-0
info.ma@boschrexroth.de
www.boschrexroth.com

© This document, as well as the data, specifications and other information set forth in it, are the exclusive property of Bosch Rexroth AG. It may not be reproduced or given to third parties without its consent. The data specified above only serve to describe the product. No statements concerning a certain condition or suitability for a certain application can be derived from our information. The information given does not release the user from the obligation of own judgment and verification. It must be remembered that our products are subject to a natural process of wear and aging.