

2-way flow control valve

RE 28155/11.10
Replaces: 11.02

1/8

Type 2FRM

Sizes 6 and 10
 Component series 1X
 Maximum operating pressure 315 bar
 Maximum flow 60 l/min



H5012

Overview of contents

Contents	Page
Features	1
Ordering code	2
Standard types	2
Symbols	2
Function, section	3
Technical data	4
Characteristic curves	5
Unit dimensions, cavities	6

Features

- Cartridge valve
- Adjustment element with internal hexagon
- With built-in check valve
- Low start-up jump

Information on available spare parts:
www.boschrexroth.com/spc

Ordering code

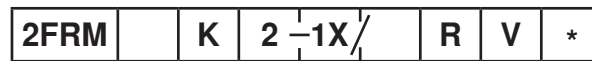

2-way flow control valve

Size 6 = 6

Size 10 = 10

Cartridge valve = K

Adjustment element

Internal hexagon = 2

Series 10 to 19 = 1X

(10 to 19: unchanged installation and connection dimensions)

Further details in clear text

Seal material

FKM seals

(Other seals on request)

Attention!

Observe compatibility of seals with hydraulic fluid used!

V =

With check valve

R =

Flow (A → B)

6Q = up to 6.0 l/min (size 6)

32Q = up to 32.0 l/min (size 6)

60Q = up to 60.0 l/min (size 10)

Preferred types and standard components can be found in the EPS (Standard Price List).

Symbols (detailed and simplified)

Detailed

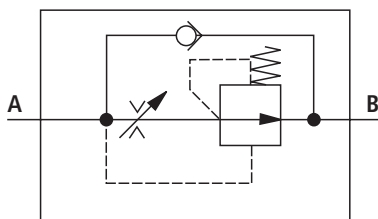

Simplified

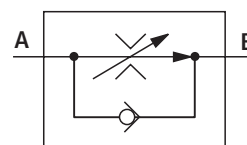

Function, section

Flow control valves type 2FRM . K are 2-way flow control valves suitable for fitting into manifold systems. They are used for maintaining a constant flow, independent of pressure and temperature.

The valve basically consists of the housing (1), adjustment element (2), throttling area (3), throttle bolt (4), pressure compensator (5) and check valve (6).

Throttling of the flow from port A to port B occurs at the throttle area (3). The throttle cross-section is changed by turning the adjustment element (2). This takes place between the throttle area (3) and the throttle bolt (4).

In order to hold the flow constant, independent from the pressure, in port B a pressure compensator (5) is fitted downstream of the throttle area (3).

The pressure compensator (5) is pressed against the plug (8) by the compression spring (7) and so stays in the open position as long as there is no flow through the valve. When flow takes place through the valve the pressure, which is present in port A, applies a force onto the pressure compensator (5). The pressure compensator moves into the compensating position until the forces are balanced. If the pressure increases in port A, then the pressure compensator (5) moves towards its closed position until the forces are balanced. Due to this continuous compensating action a constant flow is obtained. Free return flow from port B to port A is obtained via the check valve (6).

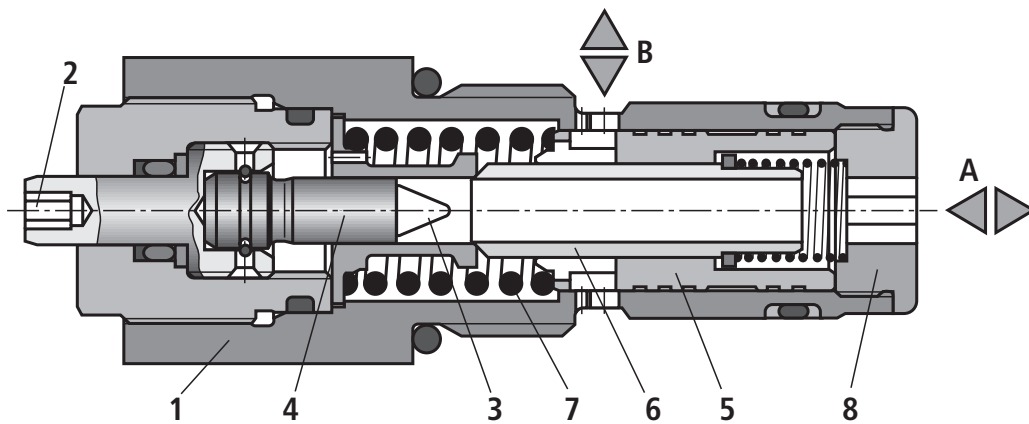

Technical data (for applications outside these parameters, please consult us!)**General**

Size		NG6	NG10
Weight	kg	0.19	0.6
Installation		Optional	
Ambient temperature range	°C	-20 to +50	

Hydraulic

Maximum operating pressure – Port A	bar	315	210
Pressure differential Δp for free return flow B → A	bar	See characteristic curves on page 5	
Minimum pressure differential	bar	18	
Pressure stable up to $\Delta p = 315 \text{ bar} / 210 \text{ bar}$	%	$\pm 3 (p_{V \max})$	
Flow	– $p_{V \max}$	l/min	6.0 32 60
	– $p_{V \min}$	cm ³ /min	50 250 500
Pressure fluid		Mineral oil (HL, HLP) to DIN 51524; Fast bio-degradable pressure fluids to VDMA 24568 (also see data sheet 90221); HETG (rape seed oil); HEPG (polyglycols); HEES (synthetic ester); Other pressure fluids on request	
Pressure fluid temperature range	°C	-20 to +80	
Viscosity range	mm ² /s	10 to 800	
Permissible max. degree of contamination of the hydraulic fluid - cleanliness class to ISO 4406 (c)		Class 20/18/15 ¹⁾	

¹⁾ The cleanliness class stated for the components must be adhered to in hydraulic systems. Effective filtration prevents faults from occurring and at the same time increases the component service life.

For the selection of the filters see www.boschrexroth.com/filter.

Characteristic curves (measured with HLP46, $\vartheta_{oil} = 40 \text{ }^\circ\text{C} \pm 5 \text{ }^\circ\text{C}$)

Size 6

Δp - q_v -characteristic curve via the check valve
(B → A) Orifice closed



Flow q_v in relation to the inlet pressure p

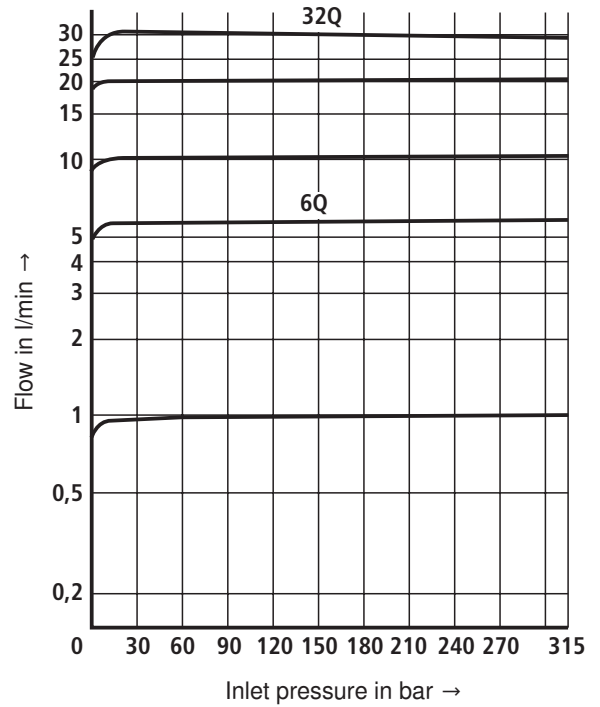

Size 10

Δp - q_v -characteristic curve via the check valve
(B → A) Orifice closed

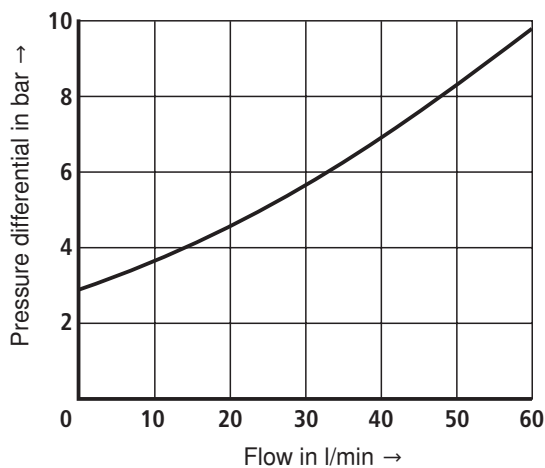

Flow q_v in relation to the inlet pressure p

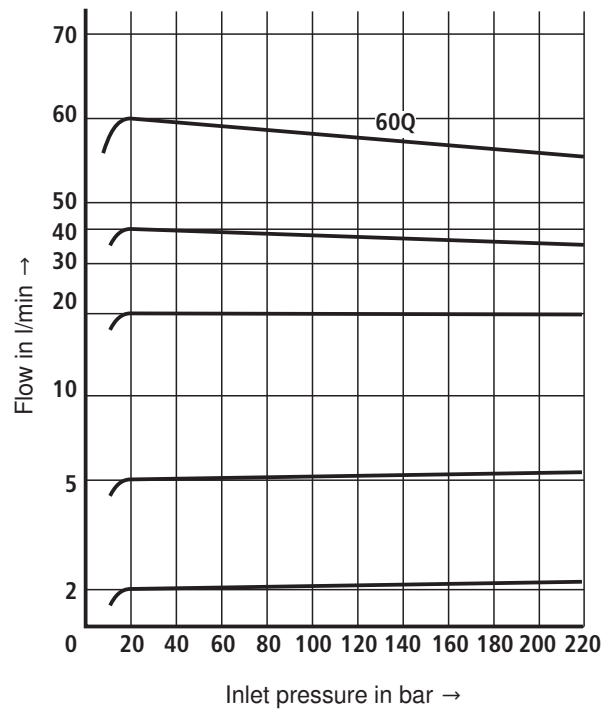

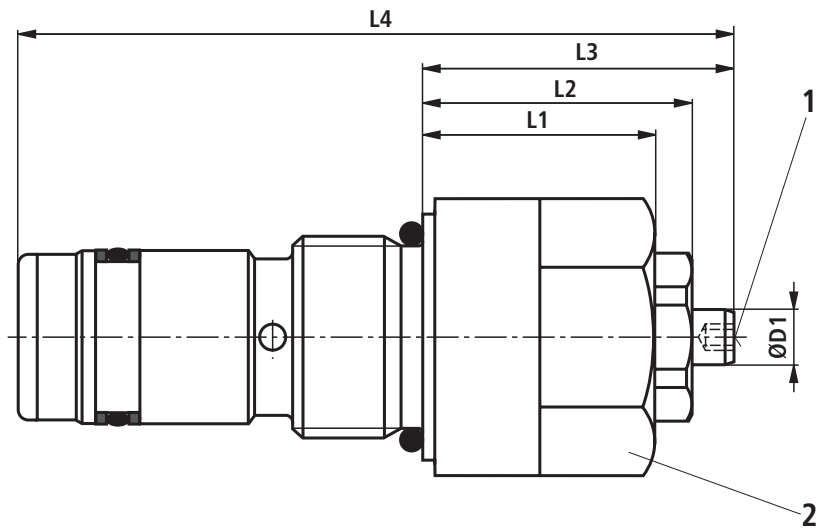
Dimensions (dimensions in mm)

Size	L1	L2	L3	L4	ØD1
6	25	29	33,5	77	6
10	36	41	45,5	109	6

- 1 Internal hexagon 3A/F
 2 – NG6: Hexagon 27A/F; $M_A = 40$ Nm
 – NG10: Hexagon 41A/F; $M_A = 120$ Nm

Cavities to DIN ISO 7789 (dimensions in mm)

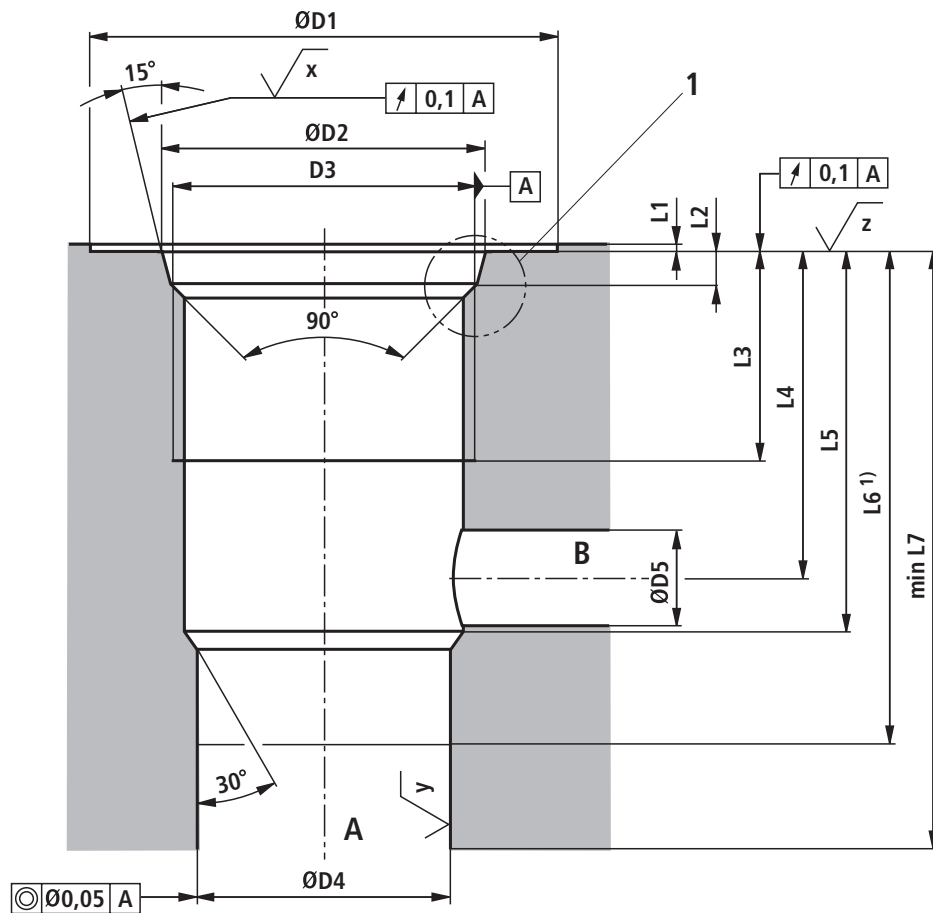

Size	L1	L2	L3	L4	L5	L6 ¹⁾	L7	ØD1	ØD2	D3	ØD4	ØD5
6	0,5	2,4 ^{+0,4}	17	24 ₋₄	28±0,1	38,5	45 ^{+0,2}	34	23,8±0,1	M22 x 1,5	19H7	7
10	0,5	3,1 ^{+0,4}	23	32 ₋₄	39±0,4	55	65	46	35,4±0,1	M33 x 2	29H8	11

1 to DIN 3852-W

¹⁾ Depth of fit

Size 6

$$\sqrt{x} = \sqrt{R_{max} 8}$$

$$\sqrt{y} = \sqrt{Rz 8}$$

$$\sqrt{z} = \sqrt{Rz 16}$$

Size 10

$$\sqrt{x} = \sqrt{Rz 8}$$

$$\sqrt{y} = \sqrt{Rz 8}$$

$$\sqrt{z} = \sqrt{Rz 25}$$

Notes

Bosch Rexroth AG
Hydraulics
Zum Eisengießer 1
97816 Lohr am Main, Germany
Phone +49 (0) 93 52 / 18-0
Fax +49 (0) 93 52 / 18-23 58
documentation@boschrexroth.de
www.boschrexroth.de

© This document, as well as the data, specifications and other information set forth in it, are the exclusive property of Bosch Rexroth AG. It may not be reproduced or given to third parties without its consent. The data specified above only serve to describe the product. No statements concerning a certain condition or suitability for a certain application can be derived from our information. The information given does not release the user from the obligation of own judgment and verification. It must be remembered that our products are subject to a natural process of wear and aging.