

Directional spool valves, direct operated, with solenoid actuation

RE 23178-XN/04.16
Replaces: 08.12

Type WE 6 ../E..XN...

Size 6
Component series 6X
Maximum operating pressure 350 bar
Maximum flow 80 l/min

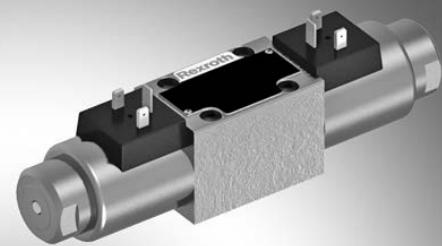

ATEX units – For potentially explosive areas



Information on the explosion protection:

- ▶ Area of application in accordance with the Explosion Protection Directive 2014/34/EU: **II 3G; II 3D**
- ▶ Type of protection of the valve solenoids:
Ex nA IIC T3 Gc / Ex tc IIIC T140 °C Dc according to EN 60079-15 / EN 60079-31

Table of contents

Contents	Page
Features	2
Ordering code	3
Symbols	4
Function, section	5
Technical data	6, 7
Electrical connection	8
Performance limits	9
Characteristic curves	9
Dimensions	10
Installation conditions	11
Accessories	11
Further information	12

Features

- 3/2-, 4/2- or 4/3-way version
- For intended use in potentially explosive atmosphere
- Porting pattern according to ISO 4401-03-02-0-05
- Wet-pin DC solenoids
- Solenoid coil rotatable by 90°
- Electrical connection as individual connection with connector according to EN 175301-803, design A
- With concealed manual override

Symbols

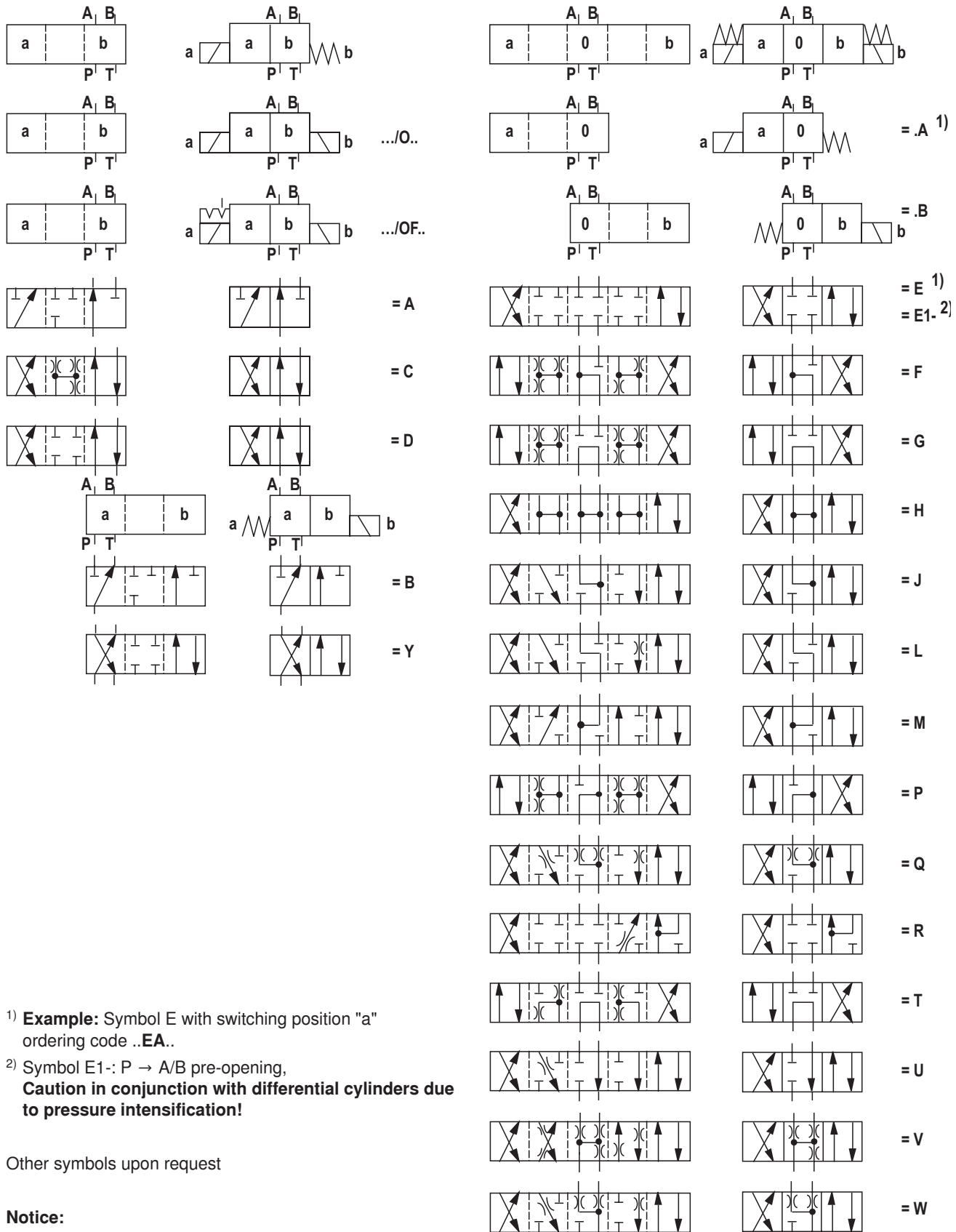

1) **Example:** Symbol E with switching position "a"
ordering code **..EA..**

2) Symbol E1-: P → A/B pre-opening,
Caution in conjunction with differential cylinders due to pressure intensification!

Other symbols upon request

Notice:
Representation according to DIN ISO 1219-1.
Hydraulic interim positions are shown by dashes.

Function, section

Directional valves of type WE are solenoid-actuated directional spool valves. They control the start, stop and direction of a fluid flow.

The directional valves basically consist of housing (1), one or two solenoids (2), control spool (3), and one or two return springs (4).

In the de-energized condition, control spool (3) is held in the central position or in the initial position by the return springs (4) (except for impulse spools). The control spool (3) is actuated by wet-pin solenoids in hydraulic fluid (2).

To ensure proper functioning, care must be taken that the pressure chamber of the solenoid is filled with hydraulic fluid.

The force of solenoid (2) acts via plunger (5) on control spool (3) and pushes the latter from its rest position to the required end position. This enables the necessary direction of flow from P → A and B → T or P → B and A → T.

After solenoid (2) was de-excited, the return spring (4) pushes the control spool (3) back to its rest position.

An optional manual override (6) allows control spool (3) to be moved without solenoid energization.

Type 4WE 6 ..6X/O...XN... (only possible with control spool symbols A, C and D)

This version is a directional valve with two spool positions and two solenoids without detent.

In the de-energized condition, there is no defined spool position.

Type 4WE 6 ..6X/OF... XN... (impulse spool, only possible with control spool symbols A, C and D)

This version is a directional valve with two spool positions, two solenoids and one detent. It alternately locks the two spool positions and the solenoid therefore does not need to be permanently energized.

Notice:

Pressure peaks in the tank line to two or several valves can result in unintended movement of the control spool in case of valves with detent! We therefore recommend that separate return lines be provided or a check valve installed in the tank line.

The tank line must not be allowed to run empty. With corresponding installation conditions, a preload valve (preload pressure approx. 2 bar) must be installed.

Due to the design principle, internal leakage is inherent to the valves, which may increase over the life cycle.

Throttle insert (valve type 4WE 6 ..6X/...XN../B..)

The use of a throttle insert is required when, due to prevailing operating conditions, flows can occur during the switching processes, which exceed the performance limit of the valve.

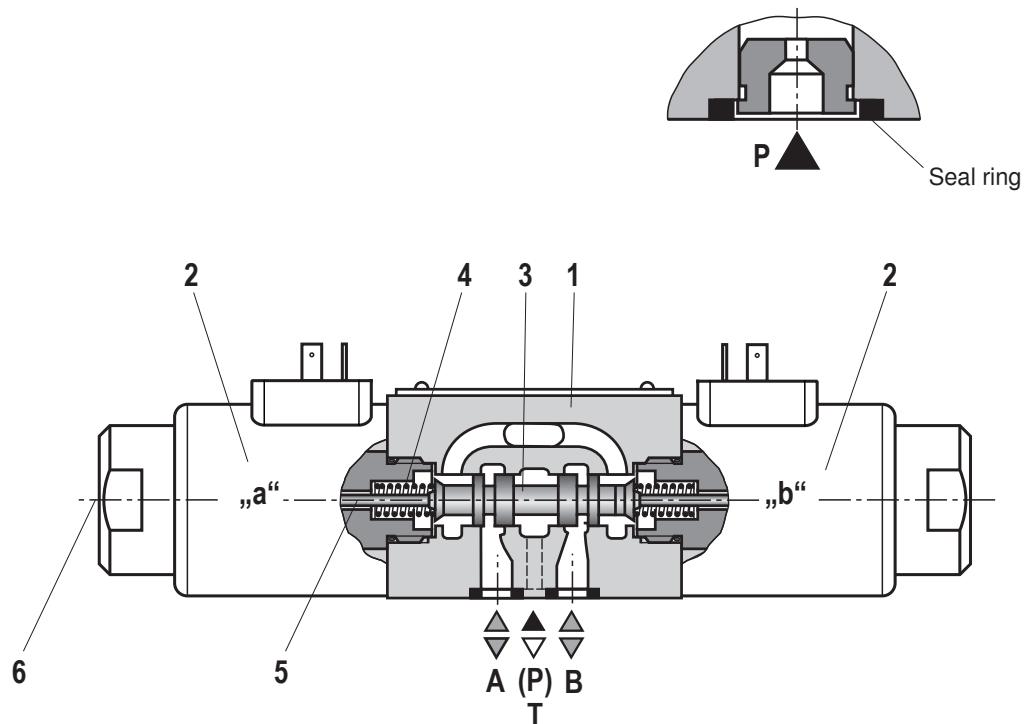

Type 4WE 6 E6X/...E..XNK4...

Technical data

general

Installation position	Any		
Ambient temperature range	°C	-20 ... +50 ¹⁾	
Storage temperature range	°C	+5 ... +40	
Maximum storage time	Years	1	
Weight	with 1 solenoid	kg	2.3
	with 2 solenoids	kg	2.85
Surface protection	Galvanized		

hydraulic

Maximum operating pressure	Port A, B, P	bar	350	With symbols A and B, port T must be used as leakage oil connection if the operating pressure exceeds the admissible tank pressure.
	Port T	bar	210	
Maximum flow	l/min		80	
Flow cross-section (spool position 0)	Control spool Q	Approx. 6 % of nominal cross-section		
	Control spool W	Approx. 3 % of nominal cross-section		
Hydraulic fluid	See table below			
Hydraulic fluid temperature range	°C		-20 ... +80 (for NBR seals) ²⁾	
	°C		-15 ... +80 (for FKM seals) ²⁾	
Viscosity range	mm ² /s		2.8 ... 500	
Maximum admissible degree of contamination of the hydraulic fluid Cleanliness class according to ISO 4406 (c)	Class 20/18/15 ³⁾			
Maximum surface temperature	°C		See information on the explosion protection on page 7	

Hydraulic fluid	Classification	Suitable sealing materials	Standards	Data sheet	
Mineral oils	HL, HLP, HLPD	NBR, FKM	DIN 51524	90220	
Bio-degradable	▶ Insoluble in water	HETG	ISO 15380	90221	
		HEES			
	▶ Soluble in water	HEPG	ISO 15380		
Flame-resistant	▶ Containing water	HFC (Fuchs Hydrotherm 46M, Petrofer Ultra Safe 620)	NBR	ISO 12922	90223



Important information on hydraulic fluids:

- ▶ For further information and data on the use of other hydraulic fluids, please refer to the data sheets above or contact us!
- ▶ There may be limitations regarding the technical valve data (temperature, pressure range, life cycle, maintenance intervals, etc.)!
- ▶ Ignition temperature > 190 °C

▶ Flame-resistant – containing water:

- Maximum pressure differential per control edge 50 bar
- Pressure pre-loading at the tank port > 20 % of the pressure differential, otherwise increased cavitation
- Life cycle as compared to operation with mineral oil HL, HLP 50 to 100 %

¹⁾ Maximum 40 °C when using the cable sets DS2513 (see page 11).

²⁾ Observe the "Special application conditions for safe application" on page 7.

³⁾ The cleanliness classes specified for the components must be adhered to in hydraulic systems. Effective filtration prevents faults and at the same time increases the life cycle of the components.

For the selection of the filters, see www.boschrexroth.com/filter.

Technical data

electric

Voltage type	Direct voltage (DC)		
Nominal voltage	V	24	
Voltage tolerance	%	± 10	
Admissible residual ripple	%	< 5	
Duty cycle / operating mode according to VDE 0580	100 % / S1 (continuous operation)		
Rated current	mA	950	
Switching times according to ISO 6403 ⁴⁾	ON	ms	25 ... 45
	OFF	ms	10 ... 25
Maximum switching frequency	1/h	15,000	
Maximum switch-off voltage peaks Solenoid	V	500, suitable damping by user required	
Nominal power at ambient temperature 20 °C	W	23	
Maximum power with 1.1 x nominal voltage and ambient temperature 20 °C	W	28.8	
Protection class according to EN 60529	IP 65 ⁵⁾		

Information on the explosion protection

Area of application according to directive 2014/34/EU	II 3G	II 3D
Type of protection of valve solenoid according to EN 60079-15 / EN 60079-31	Ex nA IIC T3 Gc	Ex tc IIIC T140 °C Dc
Maximum surface temperature ⁶⁾	°C	140
Type examination certificate Solenoid	BVS 12 ATEX E 062 X	
Type of protection valve	c (EN 13463-5)	
Ambient temperature range	°C	-20 ... +50 ¹⁾

Requirements for the mating connector

Temperature at the connector of the valve solenoid	°C	≥ 100 ⁷⁾
Area of application according to directive 2014/34/EU	II 3G; II 3D	
Protection class in plugged condition	IP 65 ⁵⁾	

Special application conditions for safe application:

- Connection lines must be passed in a pull-relieved way.
- The valve is to be installed so that no impact stresses > 4 J can take effect.
- In order to avoid dangers caused by static charge, the base and/or subplate on which the valve is to be fitted must be electrically conductive and included in the equipotential bonding.
- The valve solenoid must not be installed close to charge generating processes.
- Dust layers with a thickness > 50 mm are not admissible.

- In case of valves with two solenoids, maximally one of the solenoids may be energized at a time.
- Maximum hydraulic fluid temperature:
In case of bank assembly, as long as only one solenoid is energized at a time, and in case of individual assembly: +80 °C
In case of bank assembly when more than one solenoid is energized simultaneously: +65 °C
- The maximum temperature of the surface of the valve jacket is 110 °C. This has to be considered when selecting the connection cable and/or contact of the connection cable with the surface of the jacket is to be prevented.

⁴⁾ The switching times were determined at a hydraulic fluid temperature of 40 °C and a viscosity of 46 cSt. Deviating hydraulic fluid temperatures can result in different switching times! Switching times change dependent on operating time and application conditions.

⁵⁾ If a suitable mating connector - with sealing device, if required - and a correctly mounted electric connection are used.

⁶⁾ Surface temperature > 50 °C, provide contact protection.

⁷⁾ Transfer temperature at the connector of the valve solenoid 85 °C at ambient temperature 40 °C.

Electrical connection

The type-examination tested valve solenoid of the valve is equipped with an electrical connection according to the following table. The electrical connection of the solenoid is polarity-independent.

Electrical connections and coil connection combinations

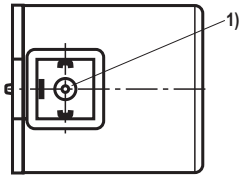
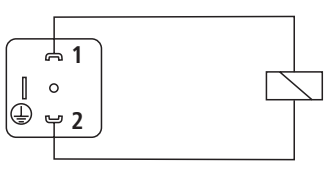
Connector ordering code	Top view	Circuit diagram	Pin	Connections, assignment
Connector, 3-pole (2+PE) according to DIN EN 175301-803 (IP65)			1 2 ⊕	Solenoid coil, polarity-independent Earthing

¹⁾ M3, maximum tightening torque $M_{A \max} = 1 \text{ Nm}$ (when using the cable set DS2513, see page 11)

Mating connector (cable set DS2513, see page 11)	
Design	DIN EN 175301-803A
Protection class according to DIN 60529	IP 65 (with correctly installed electrical connection)
Line diameter	mm 4 ... 8
Sealing	Outer sheath sealing

Over-current fuse and switch-off voltage peaks

Notice:

A fuse which corresponds to the rated current according to DIN 41571 and EN / IEC 60127 has to be connected upstream of every valve solenoid (max. $3 \times I_{\text{rated}}$).

The shut-off threshold of the fuse has to match the prospective short-circuit current of the supply source.

The prospective short-circuit current of the supply source may amount to a maximum of 1500 A.

This fuse may only be installed outside the potentially explosive atmosphere or must be of an explosion-proof design.

When inductivities are switched off, voltage peaks result which may cause faults in the connected control electronics.

The voltage peak must be damped by a suitable external circuitry. We recommend a circuitry with a suppressor diode with a limitation voltage of approx. 50 V.

Voltage data in the valve type code	Nominal voltage Valve solenoid	Rated current Valve solenoid	Recommended pre-fuse characteristics medium time-lag according to DIN EN 60127-1
G24	24 V DC	0.95 A DC	1 A

Performance limits (measured with HLP46, $\vartheta_{Oil} = 40 \text{ }^\circ\text{C} \pm 5 \text{ }^\circ\text{C}$)

Notice:

The specified switching power limits are valid for operation with two directions of flow (e.g. from P → A and simultaneous return flow from B → T).

Due to the flow forces acting within the valves, the admissible switching power limit may be considerably lower with only one direction of flow (e.g. from P → A while port B is blocked)!

(In such cases, please consult us.)

The switching power limit was established while the solenoids were at operating temperature, at 10 % under-voltage and without tank preloading.

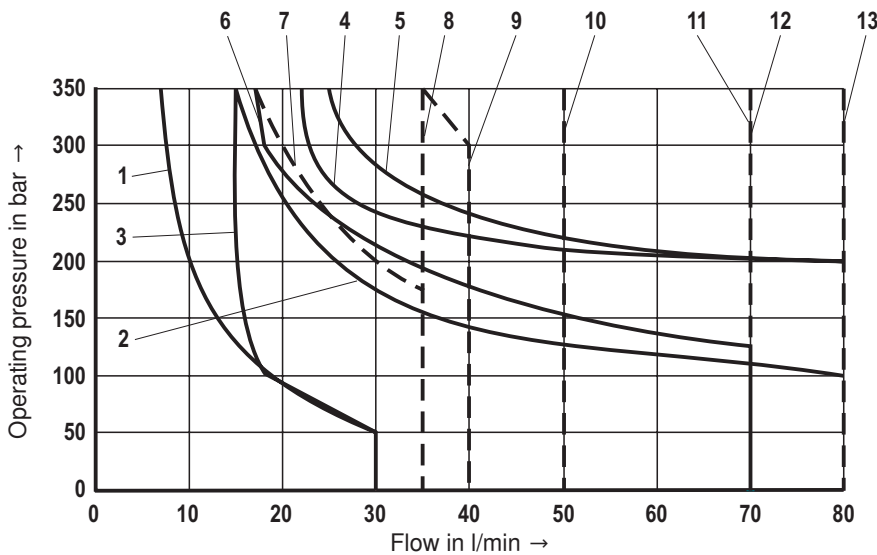

Symbol	Characteristic curve
A, B	1
J, L, U	2
V	3
D, C, Y	4
Q, W	5
A/O, A/OF	6
F, P	7
T	8
G	9
H	10
D/OF, C/OF	11
M, D/O, C/O	12
E1, R, E	13

Characteristic curves (measured with HLP46, $\vartheta_{Oil} = 40 \text{ }^\circ\text{C} \pm 5 \text{ }^\circ\text{C}$)

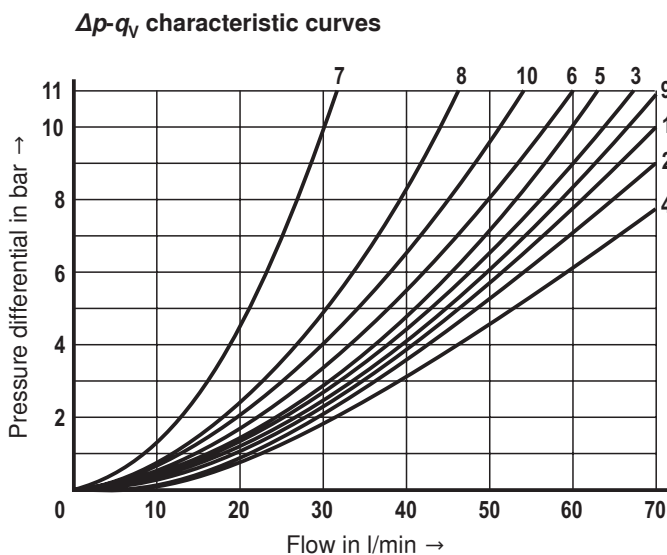

Symbol	Direction of flow					
	P - A	P - B	A - T	B - T	B - A	P - T
A, B	3	3	-	-	-	-
C46, C	1	1	3	1	-	-
D46, D, Y	5	5	3	3	-	-
E	3	3	1	1	-	-
F	1	3	1	1	-	-
T	10	10	9	9	-	8
H	2	4	2	2	-	9
J, Q	1	1	2	1	-	-
L	3	3	4	9	-	-
M	2	4	3	3	-	-
P	3	1	1	1	-	-
R	5	5	4	-	7	-
V	1	2	1	1	-	-
W	1	1	2	2	-	-
U	3	3	9	4	-	-
G	6	6	9	9	-	8

Dimensions (dimensions in mm)

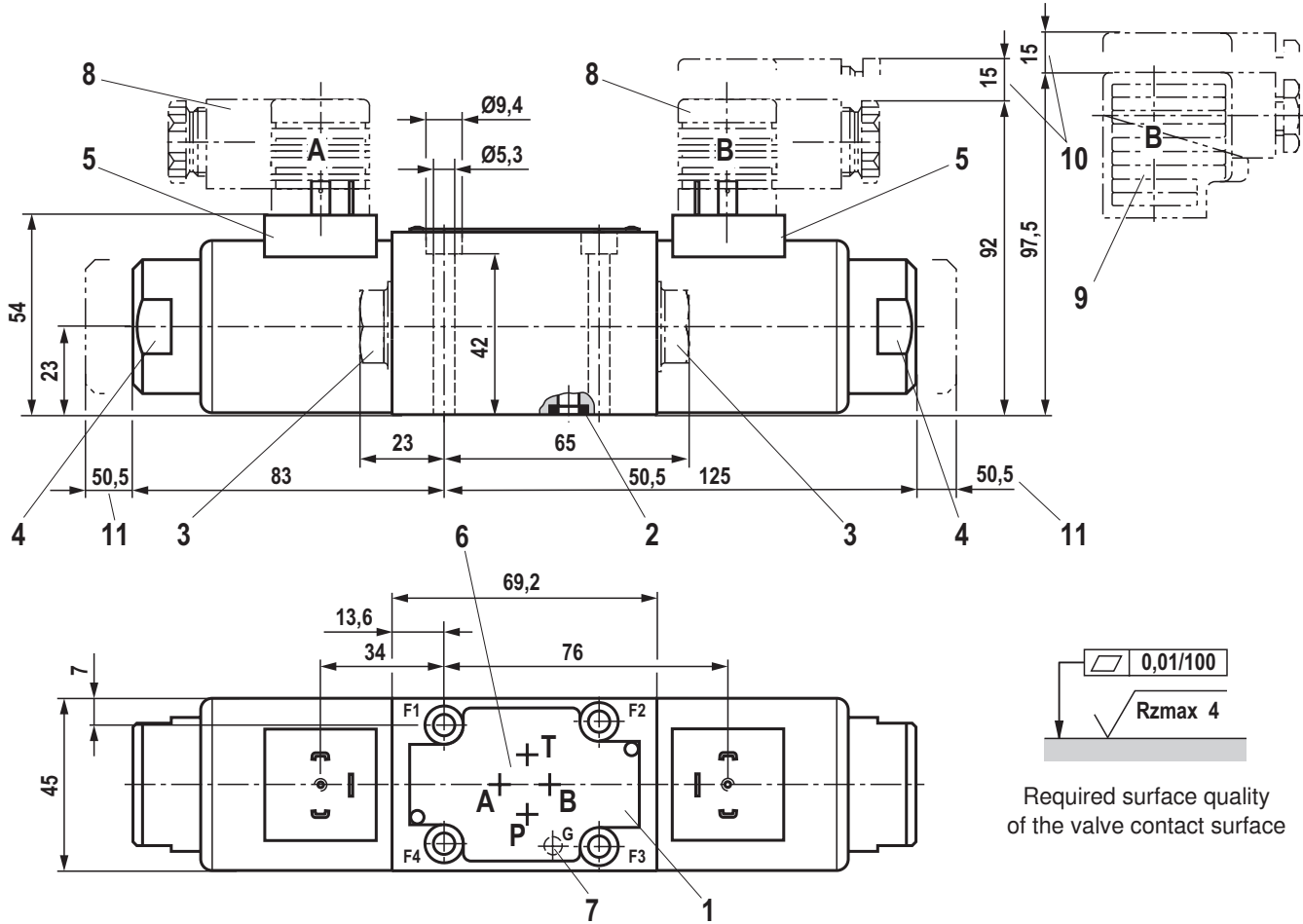

0,01/100
Rzmax 4
Required surface quality of the valve contact surface

- 1 Name plate
- 2 Identical seal rings for ports A, B, P, T
- 3 Plug screw for valves with one solenoid
- 4 Mounting nut with double edge SW32
Tightening torque $M_A = 8 + 1$ Nm
- 5 Plug-in connector according to EN 175301-803, design A
- 6 Porting pattern according to ISO 4401-03-02-0-05
- 7 Receiving hole for locking according to ISO 4401-03-02-0-05, (locking pin ISO 8752-3x8-St, material no. **R900005694**, separate order)
- 8 Mating connector or cable set DS2513 **without** circuitry for connector "K4" (separate order, see page 11 and data sheet 08006)
- 9 Mating connector **with** circuitry for connector "K4" (separate order, see data sheet 08006)
- 10 Space required to remove the mating connector
- 11 Space required to remove the coil

Valve mounting screws (separate order)
For reasons of stability, exclusively use the following valve mounting screws:
4 hexagon socket head cap screws
ISO 4762 - M5 x 50 - 10.9-flZn-240h-L
(friction coefficient $\mu_{total} = 0.09$ to 0.14);
material no. **R913000064**

Subplates (separate order) with porting pattern according to ISO 4401-03-02-0-05, see data sheet 45100.

Notice:
Subplates are no components in the sense of directive 2014/34/EU and can be used after the manufacturer of the overall system has conducted an assessment of the risk of ignition.
The "G...J3" versions are free from aluminum and/or magnesium and galvanized.

Notice:
The dimensions are nominal dimensions which are subject to tolerances.

Installation conditions (dimensions in mm)

	Individual assembly	Bank assembly
Subplate dimensions	Minimum dimensions Length ≥ 64 , width ≥ 58 , height ≥ 25	Minimum cross-section Height ≥ 60 , width ≥ 85
Thermal conductivity of the subplate	≥ 38 W/mK (EN-GJS-500-7)	
Minimum distance between the longitudinal valve axes	≥ 55 mm	

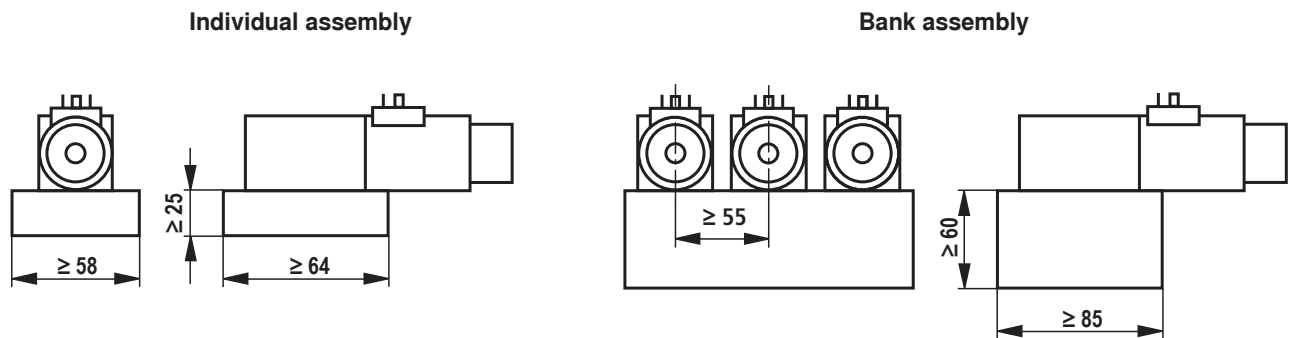
Schematic diagram**Notice:**

With regard to the hydraulic fluid temperature, observe the "Special application conditions for safe application" on page 7.

Accessories (separate order)**Mating connector**

Cable set DS2513	Length in m	Material number
Plug-in connection with securely potted-in cable according to DIN EN 175301-803, see data sheet 08006	3.0	R901200418
	5.0	R901200460
	12.0	R901200582

Further information

Subplates	Data sheet 45100
Use of non-electrical hydraulic components in a potentially explosive environment (ATEX)	Data sheet 07011
Hydraulic fluids on mineral oil basis	Data sheet 90220
Environmentally compatible hydraulic fluids	Data sheet 90221
Flame-resistant, water-free hydraulic fluids	Data sheet 90222
Flame-resistant hydraulic fluids - containing water (HFAE, HFAS, HFB, HFC)	Data sheet 90223
Directional spool valves, direct operated, with solenoid actuation	Operating instructions 23178-XN-B
Selection of filters	www.boschrexroth.com/filter
Information on available spare parts	www.boschrexroth.com/spc