

Counterbalance Valve BVE

RE 95525/11.11 1/12

Data sheet

Series 51
Size 25
Nominal pressure 350 bar
Maximum pressure 420 bar
For winch drives, open circuit

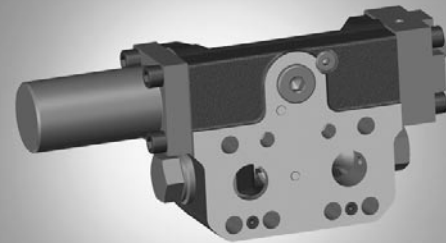

Contents

| | |
|---|----|
| Ordering code for standard program | 2 |
| Project planning and safety instructions | 3 |
| Technical data | 4 |
| Choosing the counterbalance spool version | 5 |
| Functional description | 6 |
| Application example of winch | 7 |
| Dimensions size 25 | 8 |
| Installation versions | 10 |
| Mounting the counterbalance valve | 11 |
| General instructions | 12 |

Features

- Single-action counterbalance valve especially for winch drives in open circuits
- Sensitive damping for stable lowering
- Simple adaptation to application
- Compact design and direct fitting to axial piston motors A2FM, A2FE and A6VM, A6VE
- Available in a set with axial piston motors A2FM, A2FE and A6VM, A6VE.
- Standard service line ports according to SAE J518
- Integrated brake release valve optional, with or without pressure reduction
- Good efficiency through reduced flow losses

Ordering code for standard program

| | | | | | | | | | | | | | | | | | | |
|------------|-----------|----|-----------|----|----------|-----------|----------|----|----------|----------|----|----------|------------|----|------------|------------|----------|----|
| BVE | 25 | | 38 | | / | 51 | N | | - | V | | 0 | K00 | | T30 | S00 | - | |
| 01 | 02 | 03 | 04 | 05 | | 06 | 07 | 08 | | 09 | 10 | 11 | 12 | 13 | 14 | 15 | | 16 |

Valve type

| | | |
|----|-----------------------------------|------------|
| 01 | Counterbalance valve, single-side | BVE |
|----|-----------------------------------|------------|

Size (NG)

| | | |
|----|--|-----------|
| 02 | Flow, nominal $q_{v\text{ nom}}$ 320 l/min, at $\Delta p = 20$ bar | 25 |
|----|--|-----------|

Control range (pressure when counterbalance spool starts/stops opening)

| | | | |
|----|---------------------------|--------------|----------|
| 03 | Spring value | 18 to 38 bar | W |
| | (without return pressure) | 9 to 39 bar | V |

Ports

| | | |
|----|------------------------------|-----------|
| 04 | Size allocation: see page 11 | 38 |
|----|------------------------------|-----------|

Ports for brake release

| | | |
|----|--|----------|
| 05 | With high pressure | S |
| | With reduced high pressure 21^{+4} bar (brake release valve) | L |

Series

| | | |
|----|-------------------|-----------|
| 06 | Series 5, index 1 | 51 |
|----|-------------------|-----------|

Configuration of ports and fastening threads

| | | |
|----|---|----------|
| 07 | Metric, port threads with profiled sealing ring according to DIN 3852 | N |
|----|---|----------|

Long spring cover (design: see page 8)

| | | |
|----|---------------------------------|----------|
| 08 | On port side C, lift via port C | C |
| | On port side D, lift via port D | D |

Seals

| | | |
|----|------------------------|----------|
| 09 | FKM (fluor-caoutchouc) | V |
|----|------------------------|----------|

Counterbalance spool version (selection: see page 5)

| | | |
|----|----|-----------|
| 10 | 10 | 10 |
| | 20 | 20 |

Opening characteristics of counterbalance spool

| | | |
|----|----------|----------|
| 11 | Standard | 0 |
|----|----------|----------|

Residual opening in counterbalance spool

| | | |
|----|---------|------------|
| 12 | Without | K00 |
|----|---------|------------|

Damping D1 (channel to counterbalance spool)

| | | | | |
|----|------------------------------------|--------|--------|--------------|
| 13 | Throttle pin, comparative diameter | Inlet | Outlet | |
| | | 0.4 mm | 2.0 mm | D4599 |
| | | 0.4 mm | 0.4 mm | D4545 |
| | | 0.4 mm | 0.7 mm | D4580 |

Damping D2 (reservoir outlet)

| | | |
|----|-----------------------------------|------------|
| 14 | With orifice $\varnothing 0.3$ mm | T30 |
|----|-----------------------------------|------------|

Flushing cavity

| | | |
|----|---------|------------|
| 15 | Plugged | S00 |
|----|---------|------------|

Standard / special version

| | | |
|----|---|----------|
| 16 | Standard version | 0 |
| | Standard version with installation variant, e.g. ports open or closed, contrary to standard | Y |
| | Special version | S |

Note

Short designation X on a feature refers to a special version not covered by the ordering code.

Project planning and safety instructions

Order details

When placing the order, the following information is necessary to ensure correct acceptance at our test stands:

- Motor ordering code
- Counterbalance valve ordering code
- Flow
- Application (e.g winch)
- Pressure setting of the secondary pressure relief valves in the motor
- For the design of the brake release valve, we must know the following data for the mechanical park brake:
 - the cracking pressure
 - the volume of the counterbalance spool between minimum stroke (brake closed) and maximum stroke (brake released with 21 bar)
 - the required closing time for a warm device (oil viscosity approx. 15 mm²/s)

Counterbalance valve and axial piston motor can be ordered as a ready-assembled and tested unit.

Type selection (ordering code)

Control range

The control range defines the pressure range at which the counterbalance spool starts to open.

The control range of the counterbalance spool is to be chosen so that the mechanical park brake is fully open before the counterbalance spool starts to open.

Brake release

The integrated pressure reduction valve is necessary when the mechanical brake on the gear unit cannot handle the full system pressure.

The maximum permissible brake release pressure must be agreed with the winch manufacturer. The brake release valve reduces the high pressure to the value stated.

Counterbalance spool version

The counterbalance spool version depends on the maximum flow required through the counterbalance valve.

Counterbalance spool selection for required flow as per diagram on page 5.

If the desired flow is not within the range of the counterbalance spool supplied, please contact us.

Residual opening in counterbalance spool

In winch applications, any residual opening is prohibited, since otherwise the load would not stay suspended. For that reason, version "K00" is prescribed.

Damping

The throttle pin from D1 (inlet) and the orifice D2, plus the return pressure to the reservoir, define the actual cracking pressure of the counterbalance spool in M_{P1} .

The damping D1 (outlet) and D2 define the closing speed of the counterbalance spool. The larger the comparative diameter D1 (outlet), the faster the counterbalance spool will close (see table on page 4).

For the initial equipment (prototype), we recommend damping D1 = D4599 and D2 = T30.

Safety instructions

Failure to observe any of the following points can lead to uncontrolled operating conditions with serious personal injury and material damage.

- The counterbalance valve does **not** replace the mechanical park brake. If necessary, provide mechanical brake systems.
- Counterbalance valves are usually only used in open circuits.
- System optimization (reduction) for the first prototype is recommended with regard to the valve block, axial piston motor, counterbalance valve and park brake.
- The opening and closing characteristics of the counterbalance valve and control piston in the directional valve must be mutually compatible.
- The mechanical park brake in winch drives must only be effective after the counterbalance valve spool has closed. Otherwise, the brake will be subject to wear.
- Note the maximum permissible cracking pressure of the park brake. If necessary, use the integrated pressure reduction valve as a brake release valve with reduced high pressure (version "L").
- The counterbalance valve converts the entire kinetic energy/potential energy into heat during the braking/lowering process. Consequently, ensure sufficient cooler and/or tank capacity.
- Counterbalance valves should only be operated in combination with close-by secondary pressure relief valves in order to protect the motor against pressure spikes. The table on page 11 lists the motor and port plate types for the counterbalance valve BVE25. The port plates already contain the secondary pressure-relief valves.
- Feeding at port S of the counterbalance valve reduces the risk of cavitation. Ensure sufficient pressure and flow for feeding.
- We recommend ordering an axial piston motor and counterbalance valve as a single unit. This ensures optimal matching and combined testing.
- If motor and counterbalance valve are ordered separately, we recommend that you consult our application engineers for the appropriate motor version.

Further safety-relevant measures for the application must be added as necessary by the customer.

Technical data

Hydraulic fluid

The axial piston motor used is decisive for the choice of hydraulic fluid.

Further information should be taken from our data sheets during project planning.

Operating pressure range

Pressure at service line port C or D

Nominal pressure p_{nom} _____ 350 bar absolute

Maximum pressure p_{max} _____ 420 bar absolute

Single operating period _____ 10 s

Total operating period _____ 300 h

Definition

Nominal pressure p_{nom}

The nominal pressure corresponds to the maximum design pressure.

Maximum pressure p_{max}

The maximum pressure corresponds to the maximum operating pressure within the single operating period. The sum of the single operating periods must not exceed the total operating period.

Identification of cracking pressure p_1

(value without return pressure)

The throttle chain from D_1 and D_2 is used to damp the opening and closing speeds of the counterbalance spool. The actual working pressure, measured at M_{P1} , is reduced by the throttle chain from D_1 and D_2 and actuates the counterbalance spool. The dependence of the actual pressure value at M_{P1} for the opening of the counterbalance spool on the cross-sectional area of the orifice at D_1 and D_2 is stated in the table below.

Schematic

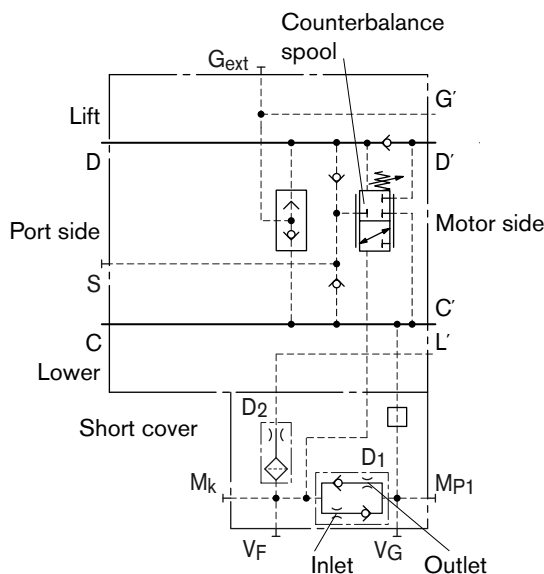

Table of values (theoretical values, without efficiency and tolerances; values rounded)

| Size | NG | | | BVE.W | BVE.V |
|---|--------------------------|-------|------------------|----------|------------------|
| Operating pressure | p | bar | Nominal pressure | 350 | 350 |
| | | | Maximum pressure | 420 | 420 |
| Flow, nominal, at $\Delta p = 20$ bar | $q_{v\ max}$ | L/min | | 320 | 320 |
| Start of opening of counterbalance spool at port M_k | Δp_{KB} | bar | | 18 | 9 |
| End of opening of counterbalance spool at port M_k | Δp_{KE} | bar | | 38 | 39 |
| Pressure reduction valve for brake release (fixed values) | Maximum control pressure | p | bar | BVE...L/ | 21+4 |
| | | | | | Start of control |
| Mass approx. | m | kg | | 18 | 18 |

Cracking pressure p_1

| Pressure spring | Throttle pin in inlet channel D1 | Orifice in reservoir outlet D2 | Pressure value at counterbalance spool | | Pressure value at port M_{P1} | |
|-----------------|----------------------------------|--------------------------------|--|--|---|---|
| | | | Start of opening Δp_{KB} [bar] (approx.) | End of opening Δp_{KE} [bar] (approx.) | Start of opening Δp_1 [bar] (approx.) | End of opening Δp_1 [bar] (approx.) |
| W | 0.45 | 0.3 | 18 | 38 | 24 | 51 |
| V | 0.45 | 0.3 | 9 | 39 | 12 | 52 |

Choosing the counterbalance spool version

Characteristic valid for BVE.../51.D). Schematic: see page 4

Pressure difference D → D'

(counterbalance spool at maximum opening)

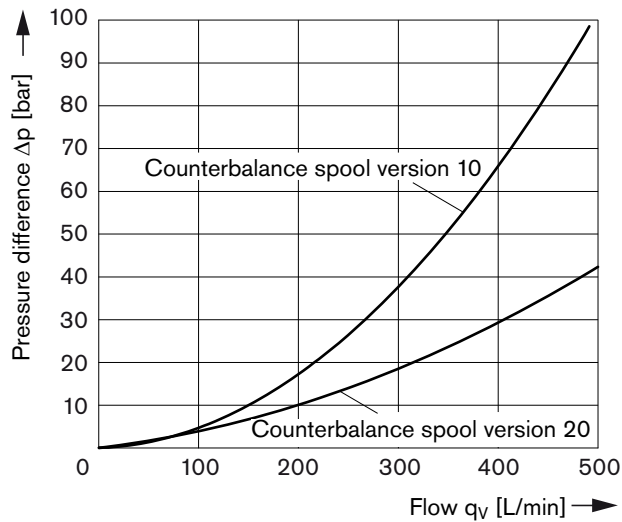

Counterbalance spool closing time

(for choosing D1 outlet damping)

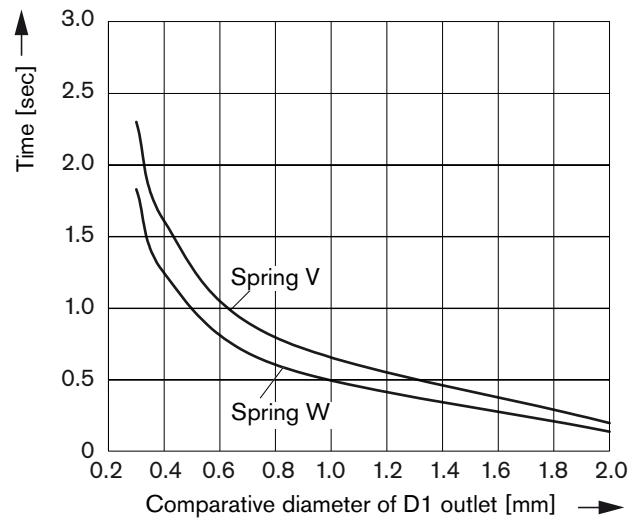

Pressure difference C' → C

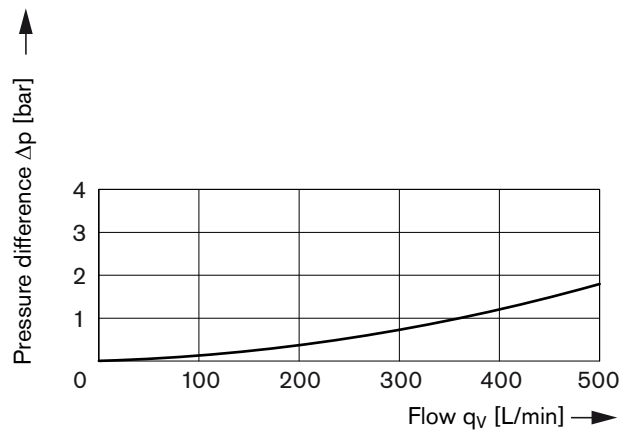

Feed pressure at port S

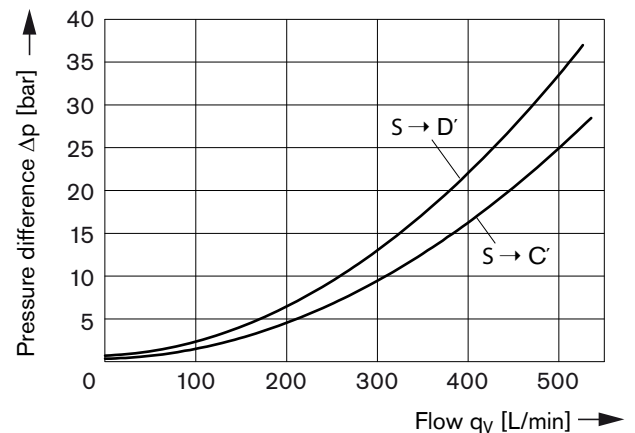

The above specifications are based on:

- Oil viscosity $\nu = 10 \text{ mm}^2/\text{s}$
- Oil temperature $\vartheta = 50 \text{ }^\circ\text{C}$
- Counterbalance spool fully open

Note

Pressure Δp of approx. 20 to 50 bar is normal for regulating the maximum flow in winch systems.
If the desired flow is not within the range of the two counterbalance spool supplied, please contact us.

Functional description

Winch counterbalance valves are designed to reduce the danger of overspeeding and cavitation of axial piston motors in open circuits. Cavitation occurs if during braking or the load-lowering process the motor speed is greater than it should be for the given inlet flow and therefore the inlet pressure collapses. If the inlet pressure drops below the given value Δp_{KE} (see table on page 4), the counterbalance spool will move towards the close position. The cross-sectional area of the counterbalance valve return channel is then reduced, creating a bottleneck in the return flow of the hydraulic fluid. The pressure increases and brakes the motor until the rotational speed of the motor is again as it should be for the given inlet flow.

Brake release

Version S

Counterbalance valve with shuttle valve and port G_{ext} (plugged), without brake release valve (pressure reduction).

The respective high pressure is balanced via the shuttle valve and is available at port G_{ext} for release of the mechanical park brake. The brake release function without pressure reduction via the brake release valve is only employed if the mechanical park brake is approved for the maximum operating pressure.

Schematic

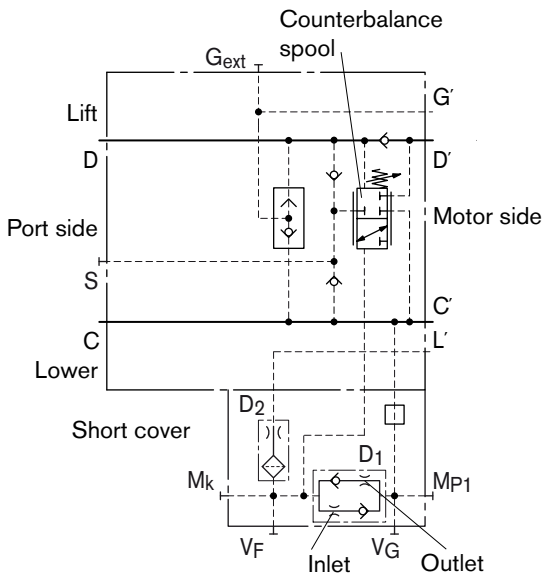

Version L

Counterbalance valve with shuttle valve, brake release valve for pressure reduction and port Br (plugged).

The respective high pressure is balanced and fed to the brake release valve (pressure reducing valve) via the shuttle valve. This opens from about 10 bar and reduces the respective operating pressure to approx. 21^{+4} bar. This brake release function is employed when the mechanical brake on the gear unit cannot handle the full system pressure.

The maximum permissible brake release pressure must be agreed with the winch manufacturer.

Schematic

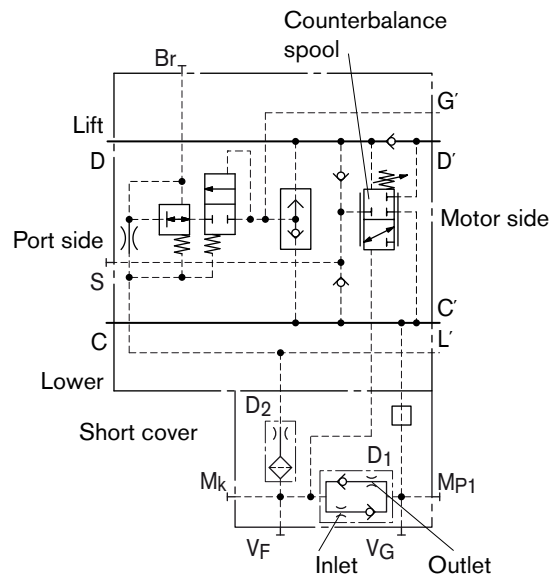

Damping D1

Installation position of throttle pin in short cover

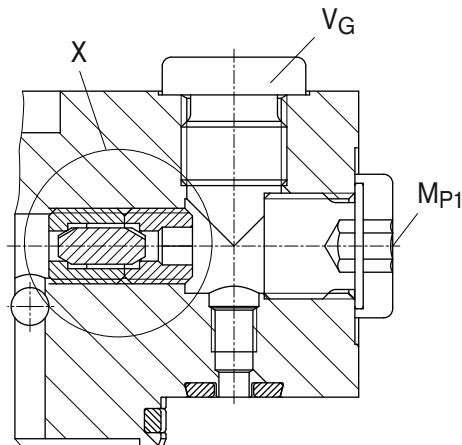

View X

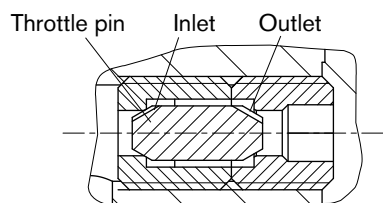

Application example of winch

Variable motor with integrated pressure-relief valves in the port plate and mounted counterbalance valve.

Winch counterbalance valve, size 25, without brake release valve (S), with counterbalance spool (10), without internal residual opening (K00, mandatory for winches), with weak damping (D4599).

e.g.: A6VM170HP5D10001F/71MWV0R4T28W0-0
+ BVE25W38S/51ND-V100K00D4599T30S00-0 fitted
to a Rexroth winch drive

Schematic

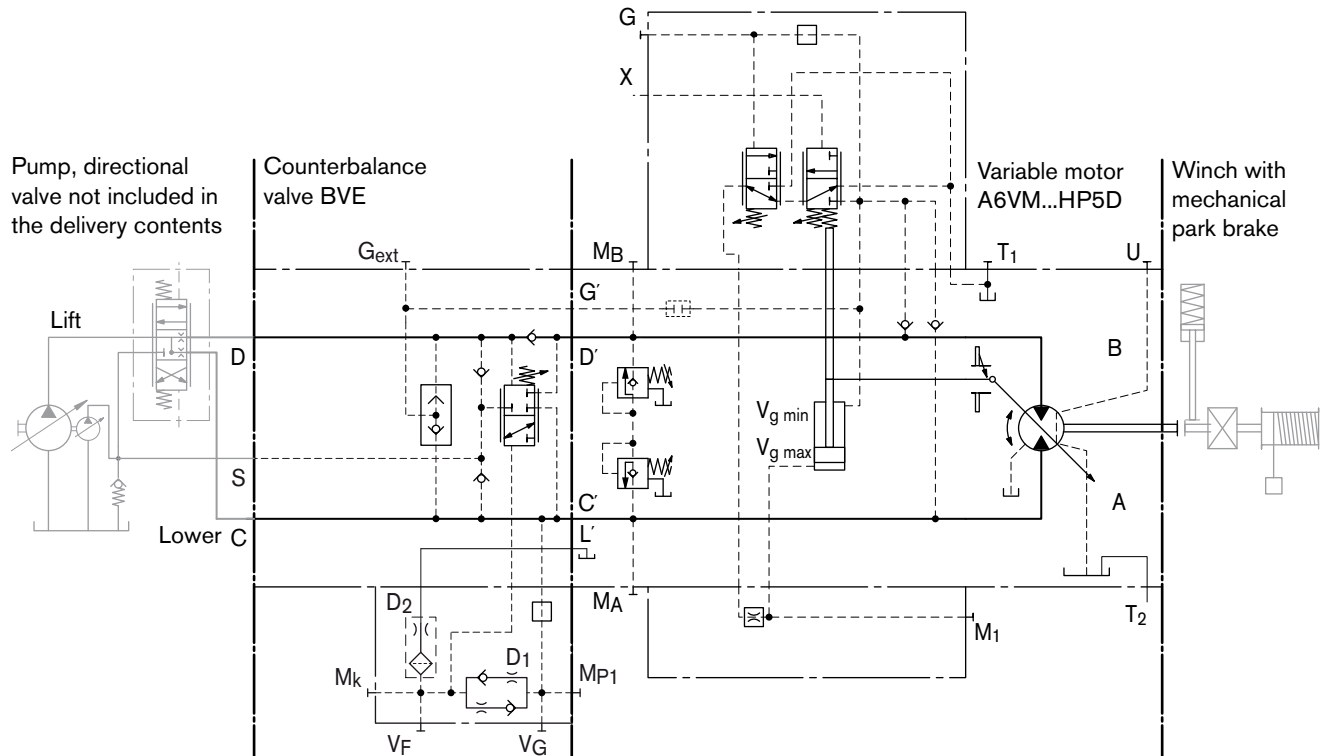

As an alternative to the above example, other axial piston motors from Bosch Rexroth (A2FM, A2FE and A6VM, A6VE) can also be used.

Dimensions size 25

Before finalizing your design, request a binding installation drawing. Dimensions in mm.

Long spring cover on port side C, lift via port C

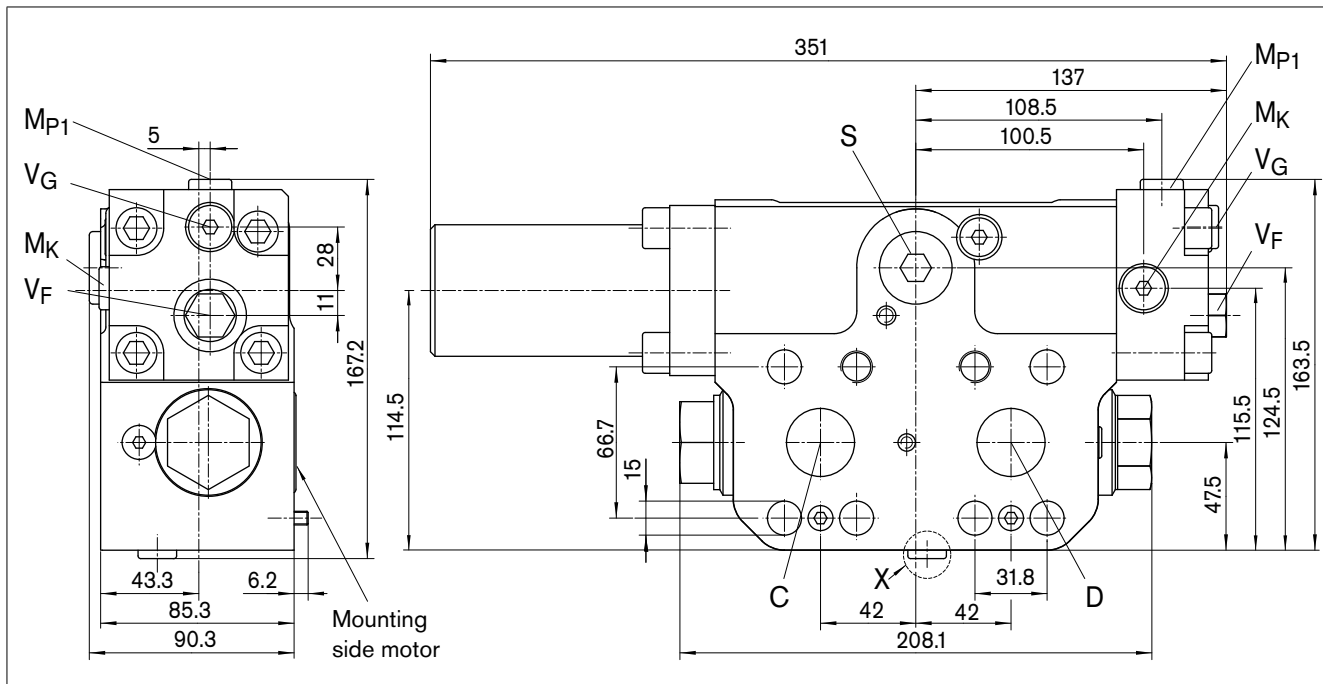

Long spring cover on port side D, lift via port D

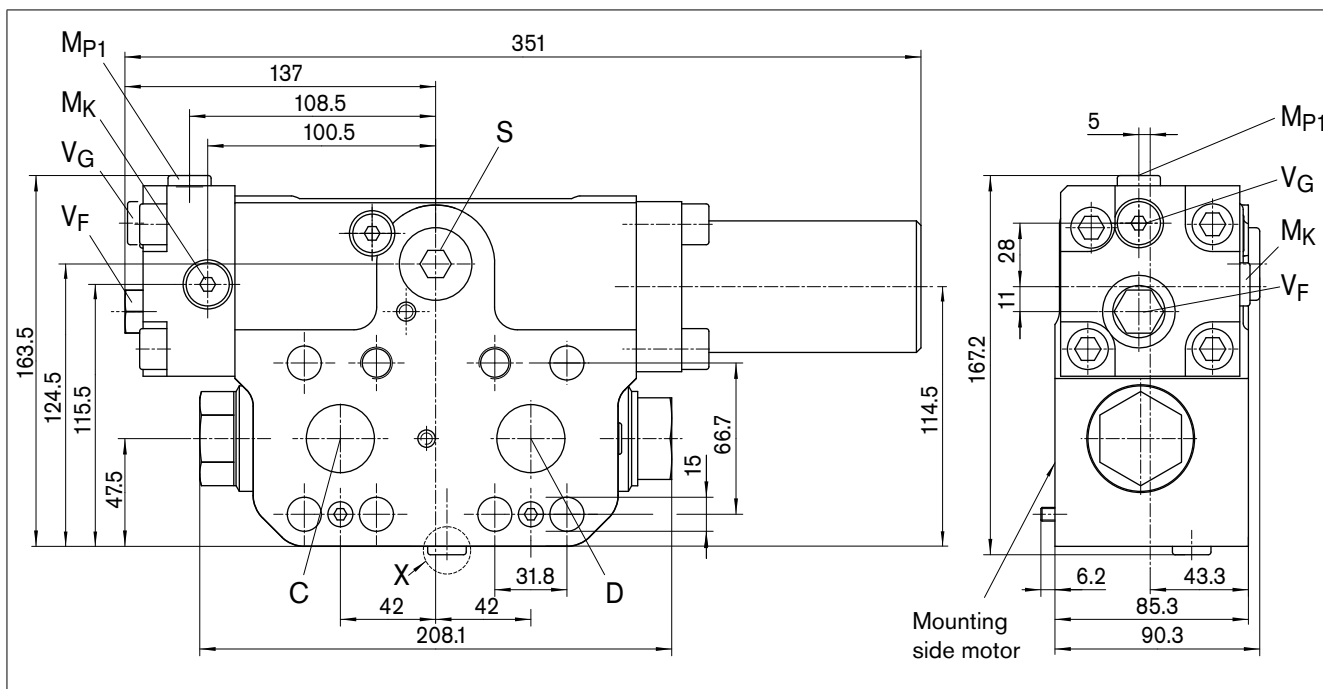

Detail X

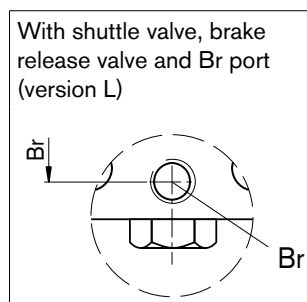
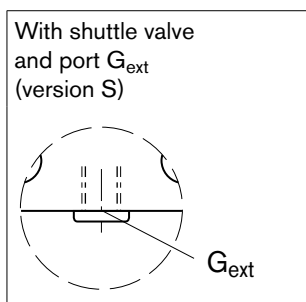

Dimensions size 25

Before finalizing your design, request a binding installation drawing. Dimensions in mm.

Ports with profiled sealing ring (ordering code designation N)

| Designation | Port for | Standard | Size ¹⁾ | Maximum pressure [bar] ²⁾ | State |
|------------------|--|------------------------|----------------------|--------------------------------------|-------|
| C, D | Service line | SAE J518 ³⁾ | 1 1/4 in | 420 | O |
| | Fastening thread C/D | DIN 13 | M14 x 2; 19 deep | | |
| S | Infeed | DIN 3852 | M27 x 2; 16 deep | 5) | X |
| Br | Brake release, reduced high pressure | DIN 3852 | M12 x 1.5; 12.5 deep | 8 | X |
| G _{ext} | Brake release, high pressure | DIN 3852 | M12 x 1.5; 12 deep | 420 | X |
| C', D' | Service channel to motor ⁴⁾ | | ø30 | 420 | O |
| G' | Selected high pressure, channel to motor ⁴⁾ | | ø4.2 | 420 | O |
| L' | Leakage channel to motor ⁴⁾ | | ø4.2 | 10 | O |
| M _{P1} | Measuring pressure A, before filter | DIN 3852 | M14 x 1.5; 12 deep | 420 | X |
| V _G | Plug for threaded channel ⁴⁾ | DIN 3852 | M14 x 1.5; 12 deep | 420 | X |
| V _F | Threaded plug for filter channel ⁴⁾ | DIN 6149 | M16 x 1.5; 13 deep | 420 | X |
| M _K | Measuring pressure at counterbalance spool | DIN 3852 | M14 x 1.5; 12 deep | 420 | X |

O-ring for sealing to axial piston motor

| | | | |
|--------|---|----------|-------------------------|
| C', D' | Service line port | AS 568 A | 37.69 x 3.53 (-S-FKM90) |
| G' | Selected high-pressure channel for HA control of A6VM motor | DIN 3771 | 9 x 2 (-N-V80G1) |
| L' | Leakage channel | DIN 3771 | 9 x 2 (-N-V80G1) |

1) Observe the general instructions on page 12 for the maximum tightening torques.

2) Momentary pressure spikes may occur depending on the application. Keep this in mind when selecting measuring devices and fittings.

3) Only dimensions according to SAE J518, metric fastening thread is a deviation from standard.

4) No customer ports. Subject to technical change

5) Application-specific. Please contact us

O = Must be connected (plugged on delivery)

X = Plugged (in normal operation)

Installation versions

Before finalizing your design, request a binding installation drawing. Dimensions in mm.

Design: A6VM

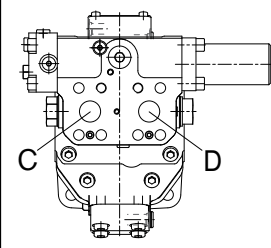
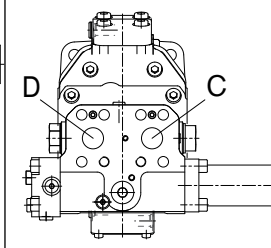
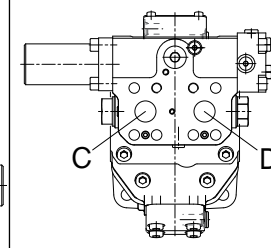
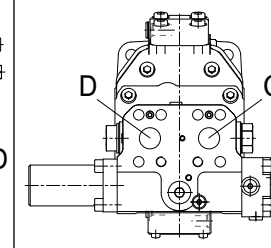
| | | | | |
|---|---|---|--|---|
| Direction of rotation: lift | Clockwise | | Counter-clockwise | |
| Flow direction at motor | A to B | | B to A | |
| Counterbalance valve effect at motor port | A | | B | |
| Installation version of port plate | Start of control $V_{g \max}$ Lifting winch | Start of control $V_{g \min}$ Pulling winch – not permissible for lifting winch | Start of control $V_{g \max}$ Lifting winch | Start of control $V_{g \min}$ Pulling winch – not permissible for lifting winch |
| Long spring cover at BVE | On port side D | On port side C | On port side C | On port side D |
| Counterbalance valve ordering code | BVE25.../51.D | BVE25.../51.C | BVE25.../51.C | BVE25.../51.D |
| |  |  |  |  |

Start of control $V_{g \max}$, negative control

HP5, HP6, EP5, EP6, HZ5, HZ7, EZ5, EZ6, EZ7, EZ8, DA0, DA1, DA2

Start of control $V_{g \min}$, positive control – not permissible for lifting winch

HP1, HP2, EP1, EP2, HA1, HA2

Design: A2F

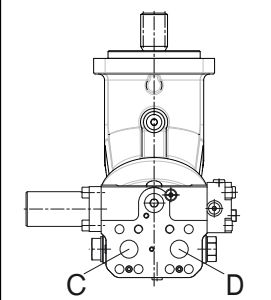
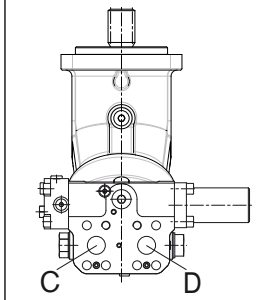
| | | |
|---|---|---|
| Direction of rotation: lift | Clockwise | Counter-clockwise |
| Flow direction at motor | A to B | B to A |
| Counterbalance valve effect at motor port | A | B |
| Long spring cover at BVE | On port side C | On port side D |
| Counterbalance valve ordering code | BVE25.../51.C | BVE25.../51.D |
| |  |  |

Mounting the counterbalance valve

Before finalizing your design, request a binding installation drawing. Dimensions in mm.

When delivered, the counterbalance valve is mounted to the motor with two tacking screws (transport protection). The tacking screws may not be removed while mounting the service lines! If the counterbalance valve and motor are delivered separately, the counterbalance valve must first be mounted to the motor port plate using the provided tacking screws. The counterbalance valve is finally mounted to the motor by screwing on the SAE flange with the following screws:

6 screws (1, 2, 3, 4, 5, 8) _____ length B1+B2+B3
 2 screws (6, 7) _____ length B3+B4

Tighten the screws in two steps in the specified sequence from 1 to 8 (see following scheme).

In the first step, the screws must be tightened with half the tightening torque, and in the second step with the maximum tightening torque (see following table).

| Thread | Strength class | Tightening torque [Nm] |
|--------|----------------|------------------------|
| M10 | 10.9 | 75 |
| M12 | 10.9 | 130 |
| M14 | 10.9 | 205 |

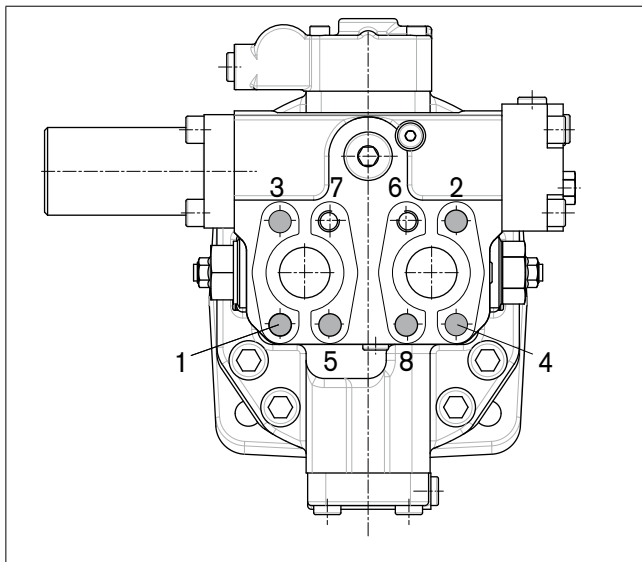

A6VM

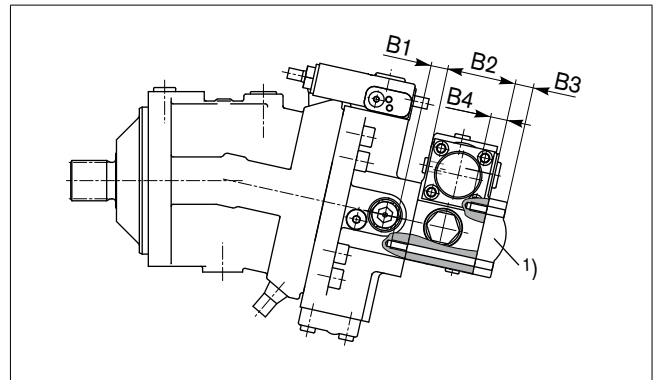

A2FM

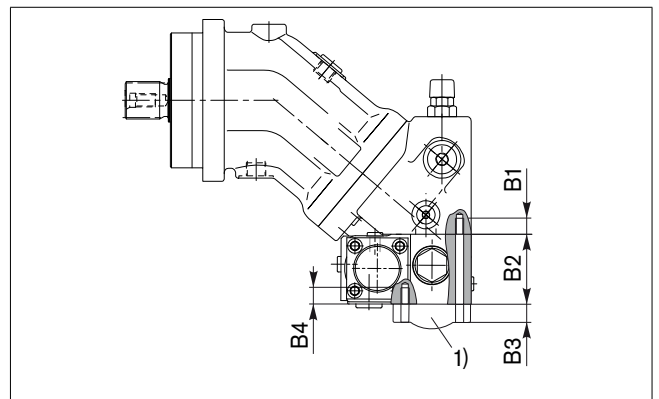

A2FE

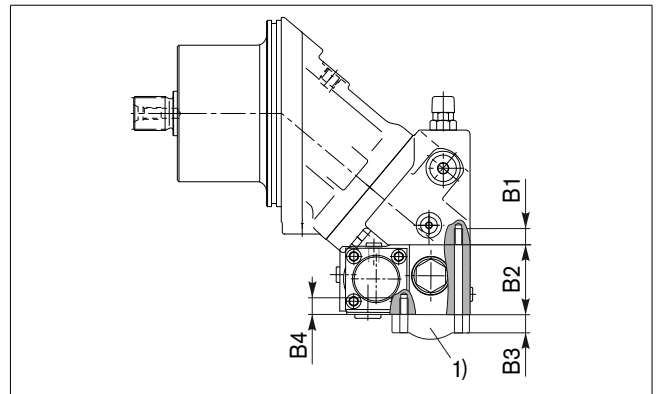

| Axial piston motor | A2FM, A2FE | A6VM/63, | A6VE/63 | A6VM/71 | A6VE/71 |
|---|--------------------|---------------|----------|---------------|----------|
| Size | 107, 125, 160, 180 | 107, 140, 160 | 107, 160 | 115, 150, 170 | 115, 170 |
| Motor port plate required (with secondary pressure-relief valves, mutual bleed-off) | 181 | 380 | 380 | 8 | 8 |
| Dimension B1 ¹⁾ | M14 x 2; 19 deep | | | | |
| Dimension B2 | 85 | | | | |
| Dimension B3 | Customer-specific | | | | |
| Dimension B4 | M14 x 2; 19 deep | | | | |

1) Minimum necessary thread length 1 x ø

General instructions

- The BVE counterbalance valve is designed to be used in an open circuit.
- The project planning, installation and commissioning of the axial piston unit requires the involvement of qualified personnel.
- Before using the counterbalance valve, please read the corresponding instruction manual completely and thoroughly. If necessary, these can be requested from Bosch Rexroth.
- During and shortly after operation, there is a risk of burns on the counterbalance valve and the axial piston unit. Take appropriate safety measures (e.g. by wearing protective clothing).
- Depending on the operating conditions of the counterbalance valve (operating pressure, fluid temperature), the characteristic may shift.
- Service line ports:
 - The ports and fastening threads are designed for the specified maximum pressure of the counterbalance valve. The machine or system manufacturer must ensure that the connecting elements and lines correspond to the specified operating conditions (pressure, flow, hydraulic fluid, temperature) with the necessary safety factors.
 - The service line ports and function ports can only be used to accommodate hydraulic lines.
- The data and notes contained herein must be adhered to.
- The product is not approved as a component for the safety concept of a general machine according to ISO 13849.
- The following tightening torques apply:
 - Fittings:
Observe the manufacturer's instructions regarding the tightening torques of the fittings used.
 - Mounting bolts:
For mounting bolts with metric ISO thread according to DIN 13, we recommend checking the tightening torque in individual cases in accordance with VDI 2230.
 - Female threads of the counterbalance valve or axial piston unit:
The maximum permissible tightening torques $M_{G \max}$ are maximum values of the female threads and must not be exceeded. For values, see the following table.
 - Threaded plugs:
For the metallic threaded plugs supplied with the counterbalance valve or axial piston unit, the required tightening torques of threaded plugs M_V apply. For values, see the following table.

| Ports | | Maximum permissible tightening torque of the female threads $M_{G \max}$ | Required tightening torque of the threaded plugs M_V ¹⁾ | WAF hexagon socket of the threaded plugs |
|----------|----------------|--|--|--|
| Standard | Size of thread | | | |
| ISO 3852 | M12 x 1.5 | 50 Nm | 25 Nm ²⁾ | 6 mm |
| | M14 x 1.5 | 80 Nm | 35 Nm | 6 mm |
| | M27 x 2 | 330 Nm | 135 Nm | 12 mm |

- 1) The tightening torques apply for screws in the "dry" state as received on delivery and in the "lightly oiled" state for installation.
 2) In the "lightly oiled" state, the M_V is reduced to 17 Nm for M12 x 1.5.