

## RE 26 915/10.97

Replaces: 01.97



## Pressure reducing valve, pilot operated, type 3DR

Nominal size 10

Series 6X

Maximum operating pressure 315 bar

Maximum flow 120 L/min

H/A/D 5845/97



Type 3DR 10 P5-6X/315Y/00M

### Contents

#### Description

Features	
Ordering details	
Function, section, symbol	
Technical data	
Characteristic curves	
Unit dimensions	

### Features

<b>Page</b>	
1	– Valve for the reduction (P to A) and limitation (A to T) of a pressure in a hydraulic system
1	– For sub-plate mounting, porting pattern DIN 24 340 form A, ISO 4401 and CETOP-RP 121 H, sub-plates to catalogue sheet RE 45 054 (separate order)
2	
3	
3, 4	– 4 pressure stages
5	– 4 adjustment elements:
	• rotary knob
	• sleeve with hexagon and protective cap
	• lockable rotary knob with scale
	• rotary knob with scale

### Ordering details

3DR	10	P	-6X/	Y/	00	*
3-way pressure reducing valve						
Nominal size 10		= 10				
Sub-plate mounting		= P				
<b>Adjustment element</b>						
Rotary knob		= 4				
Sleeve with hexagon and protective cap		= 5				
Lockable rotary knob with scale		= 6 <sup>1)</sup>				
Rotary knob with scale		= 7				
Series 60 to 69 (60 to 69: unchanged installation and connection dimensions)		= 6X				
Setable pressure up to 50 bar		= 50				
Setable pressure up to 100 bar		= 100				
Setable pressure up to 200 bar		= 200				
Setable pressure up to 315 bar		= 315				
Further details in clear text						
M =		NBR seals				
V =		FPM seals (other seals on request)				
<b>⚠ Attention!</b> The compatibility of the seals and pressure fluid has to be taken into account!						
00 =		without stroke limiter				
Y =		<b>Pilot oil supply</b> pilot oil supply internal, pilot oil supply external				
Preferred types and standard components are highlighted in the RPS (Rexroth Price list Standard).						

<sup>1)</sup> H-key with material no. 00008158 is included within the scope of supply

**Function, section, symbol**

The pressure valve type 3DR is a pilot operated 3-way pressure reducing valve with pressure limitation in the secondary circuit. It is used for the reduction of pressure in a hydraulic system.

The pressure reducing valve consists mainly of main valve (1) with control spool (2) and pilot control valve (3) with pressure adjustment element (10).

At rest the valve is open. Pressure fluid can flow unrestricted from port P to port A. The pressure in port A is applied via the channel (4) to the spool area opposite to the compression spring (9). At the same time the pressure is applied via the orifice (6) to the spring loaded side of the control spool (2) and via channel (5) to the ball (7) in the pilot control valve (3).

Dependent on the setting of the compression spring (11) a pressure builds up in front of the ball (7) and in channel (5) which holds the control spool (2) in an open position. Pressure fluids flows from port P via the control spool (2) into port A, until a pressure is built up in port A, which exceeds the pressure value set at the compression spring (11) and lifts the ball (7).

The control spool (2) moves into the closed position. The required reduced pressure is achieved when a balance between the pressure in port A and the pressure value set at the compression spring (11) is reached.

If the pressure in port A continues to rise at the actuator through external forces the control spool (2) is moved still further against the compression spring (9). Thus port A is connected to port T via the control lands (8) at the control spool (2). Enough pressure fluid flows to tank to ensure that the pressure does not rise any further.

The pilot oil return from the spring chamber (12) is always external via the control line (13) to port Y. This must always flow at zero pressure to tank.

The pressure gauge connection (14) makes it possible to monitor the reduced pressure in port A.

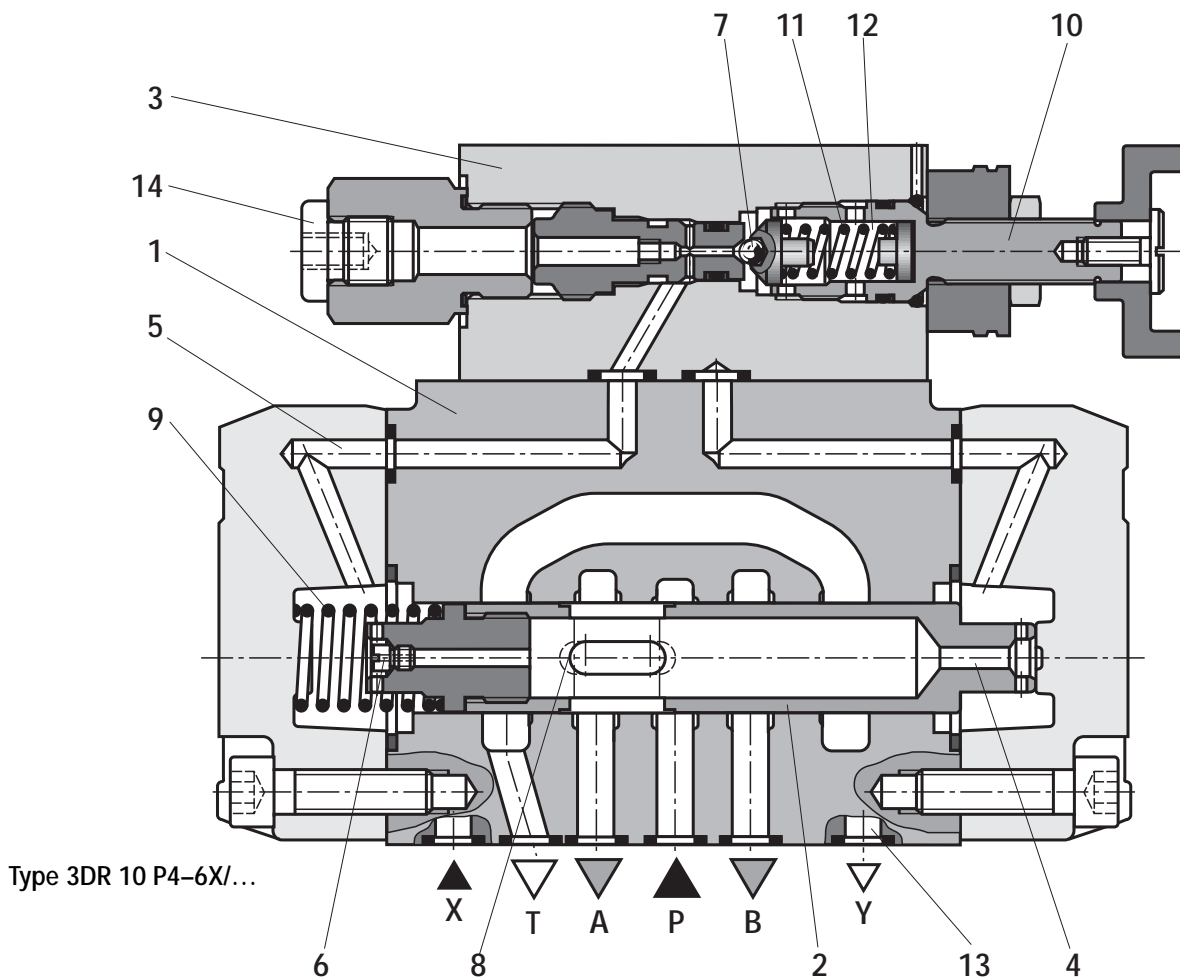

Type 3DR 10 P4-6X/...

**Symbol**

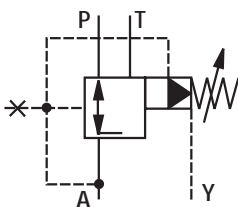

**Technical data** (for applications outside these parameters, please consult us!)**General**

Description	pressure reducing valve
Graphic symbol	see page 2
Type code	see page 1
Mounting style	sub-plate mounting
Connection type	indirect connection via sub-plate or manifold block, porting pattern to DIN 24 340 form A, ISO 4401 and CETOP-RP 121 H
Nominal size	10
Weight	kg 6.0
Installation	optional
Direction of flow	see graphic symbol on page 2
Ambient temperature range	°C – 30 to + 50

**Hydraulic data**

Nominal pressure	bar	315
Maximum operating pressure at ports P and A	bar	315
Maximum operating pressure at port Y	bar	separate and at zero pressure to tank
Setable pressure	minimum	bar dependent on the flow (see characteristic curves on page 4)
	maximum	bar 50; 100; 200; 315
Pressure fluid	mineral oil (HL, HLP) to DIN 51 524 <sup>1)</sup> ; fast bio-degradable pressure fluids to VDMA 24 568 (also see RE 90 221); HETG (rape seed oil) <sup>1)</sup> ; HEPG (polyglycol) <sup>2)</sup> ; HEES (synthetic ester) <sup>2)</sup> ; other pressure fluids on request	
Pressure fluid temperature range	°C	– 30 to + 80 with NBR seals
	°C	– 20 to + 80 with FPM seals
Viscosity range	mm <sup>2</sup> /s	10 to 800
Maximum flow	L/min	120
Degree of contamination	maximum permissible degree of contamination of the pressure fluid is to NAS 1638 class 9. We, therefore, recommend a filter with a minimum retention rate of $\beta_{10} \geq 75$ .	

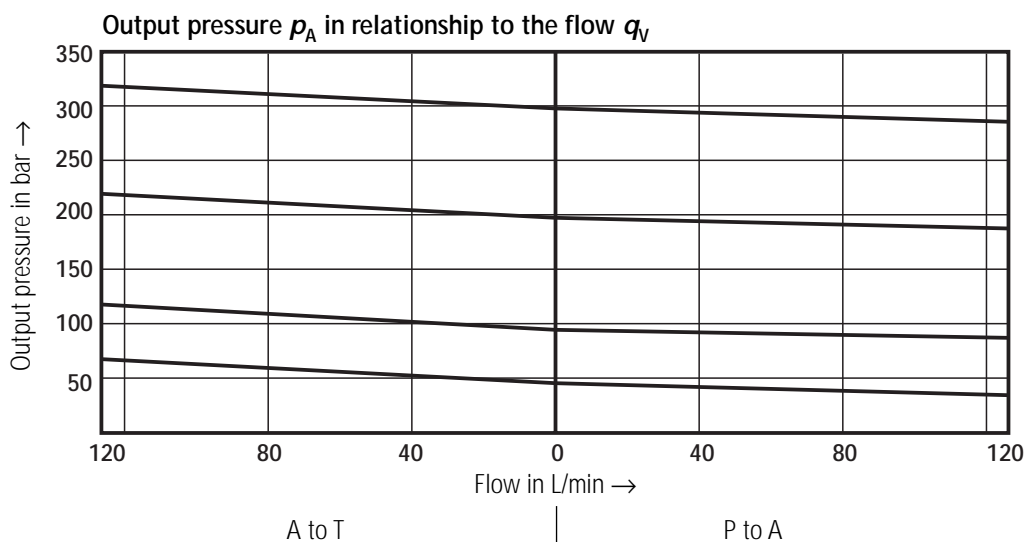
**Characteristic curves** (measured at  $v = 41 \text{ mm}^2/\text{s}$  and  $\vartheta = 50 \text{ }^\circ\text{C}$ )

The characteristic curves are valid for output pressure  $p_T = \text{zero}$  over the entire flow range.

**Characteristic curves** (measured at  $v = 41 \text{ mm}^2/\text{s}$  and  $\vartheta = 50 \text{ }^\circ\text{C}$ )

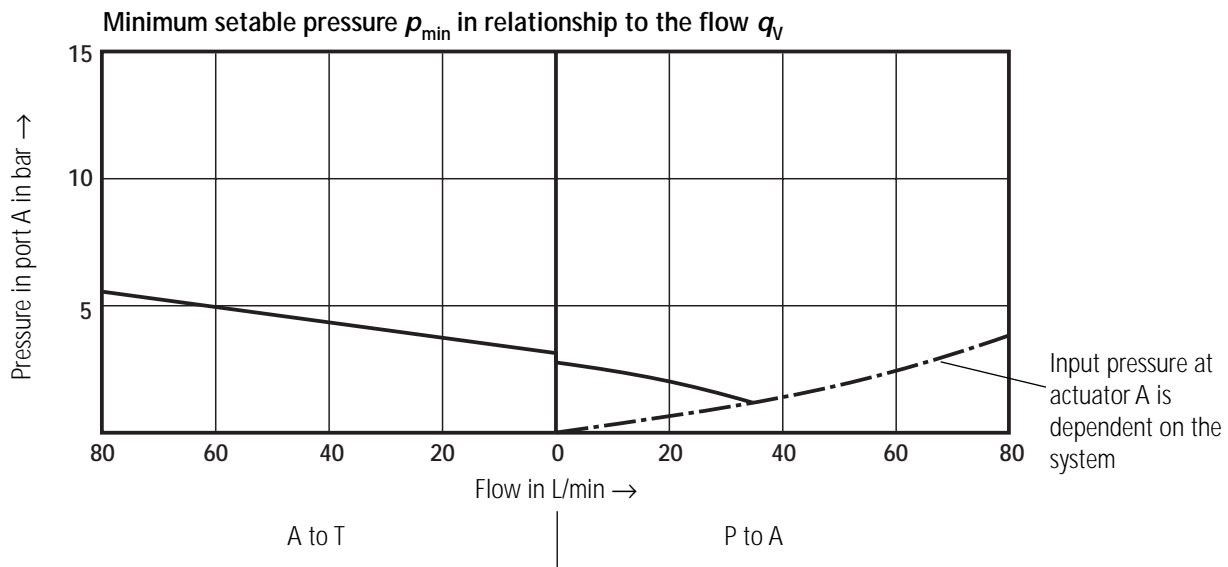
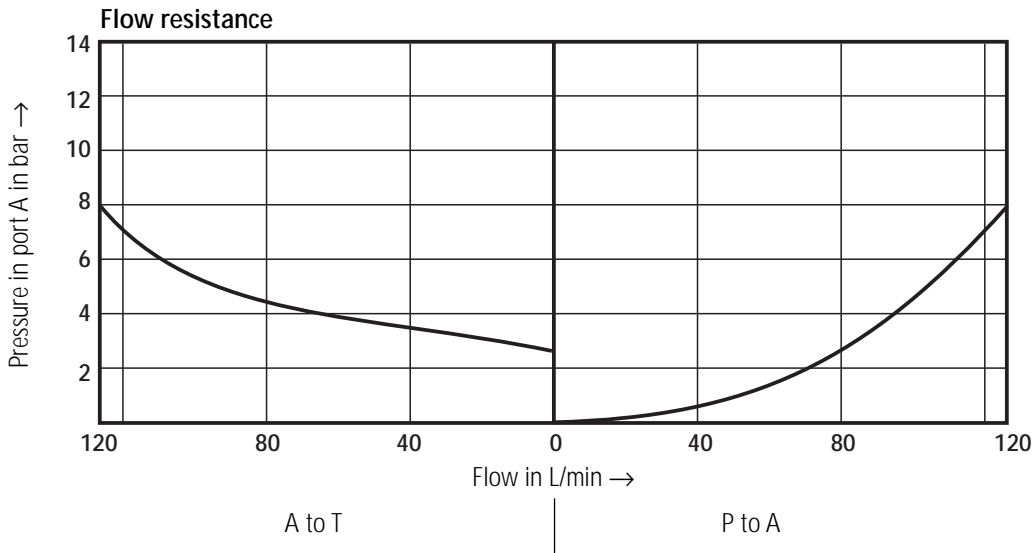

The characteristic curves are valid for output pressure  $p_T = \text{zero}$  over the entire flow range.

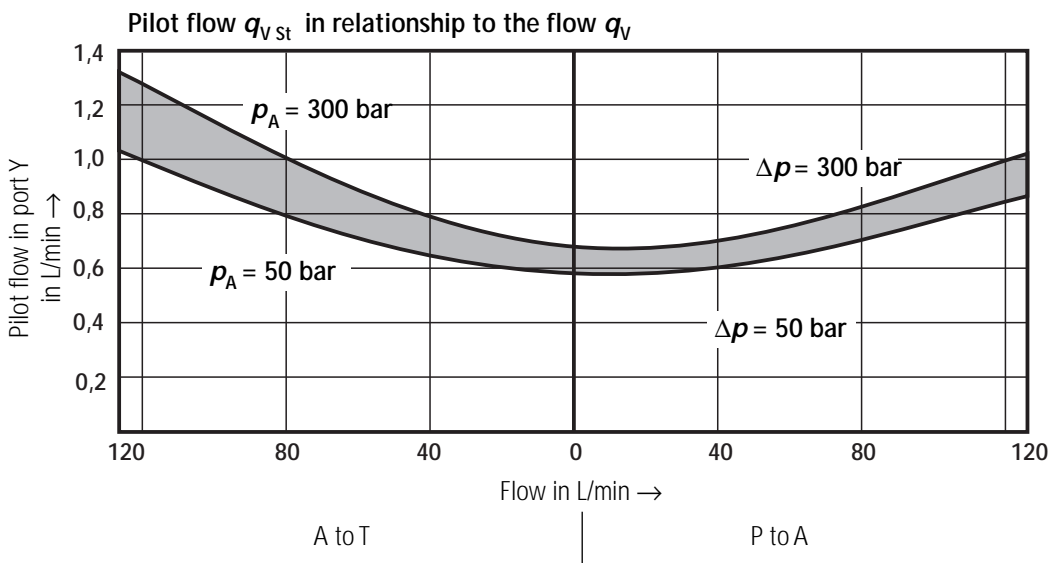

## Unit dimensions

(Dimensions in mm)

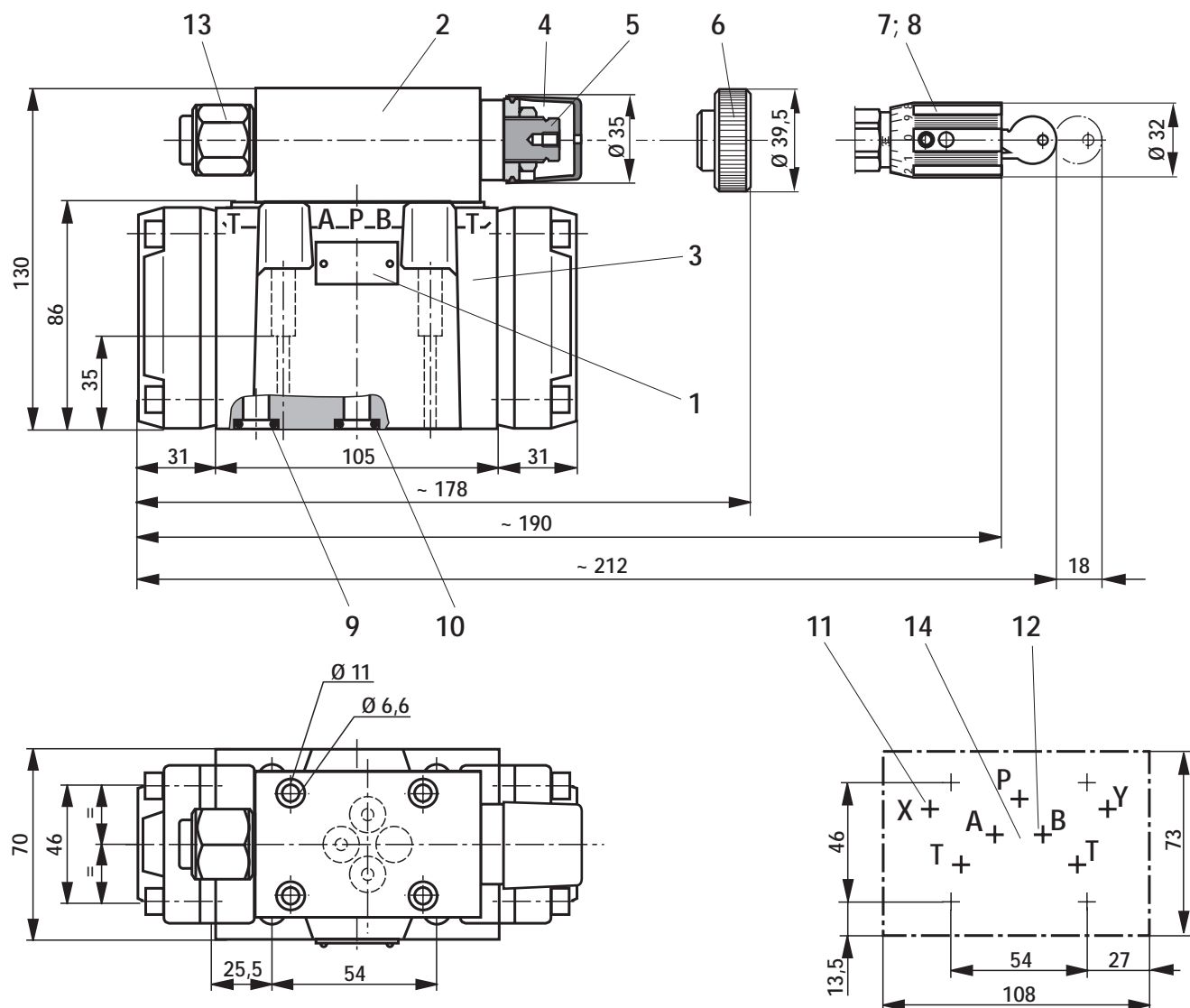

- 1 Name plate
- 2 Pilot control valve
- 3 Main valve
- 4 Adjustment element "5"
- 5 Hexagon A/F 10
- 6 Adjustment element "4"
- 7 Adjustment element "6"
- 8 Adjustment element "7"
- 9 O-rings 10.82 x 1.78 for ports X and Y
- 10 O-rings 12 x 2 for ports A, B, P and T
- 11 Port X has to be plugged in the sub-plate.

- 12 Port B has to be plugged in the sub-plate.
  - 13 Pressure gauge connection
  - 14 Valve mounting surface, porting pattern to DIN 24 340 form A, ISO 4401 and CETOP-RP 121 H
- sub-plates** G535/01 (G 3/4)  
G536/01 (G 1)
- to catalogue sheet RE 45 054 must be ordered separately.
- Valve fixing screws**  
4 off M6 x 45 DIN 912-10.9,  
 $M_A = 15.5$  Nm,  
must be ordered separately.

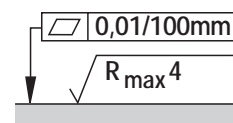

Required surface finish of mating piece

## Notes

---

---

**Mannesmann Rexroth AG**  
**Rexroth Hydraulics**

D-97813 Lohr am Main  
Jahnstraße 3-5 • D-97816 Lohr am Main  
Telefon 0 93 52 / 18-0  
Telefax 0 93 52 / 18-10 40 • Telex 6 89 418-0

**Mannesmann Rexroth Limited**

Cromwell Road, St. Neots,  
Huntingdon, Cambs. PE19 2ES  
Tel: (01480) 476041  
Fax: (01480) 219052

The specified data is for product description purposes only and may not be deemed to be guaranteed unless expressly confirmed in the contract.