

Pressure reducing valve, pilot operated

RE 26850/10.05
Replaces: 02.03

1/6

Type DR 10 K

Size 10
Component series 3X
Maximum operating pressure 315 bar
Maximum flow 100 l/min

K4278/7

Table of contents

Contents	Page
Features	1
Ordering code	2
Standard types	2
Function, section, symbol	2
Technical data	3
Characteristic curves	4
Unit dimensions	5
Mounting cavity	6

Features

- Cartridge valve
- 4 pressure stages
- 4 adjustment elements, optional:
 - Rotary knob
 - Sleeve with hexagon and protective cap
 - Lockable rotary knob with scale
 - Rotary knob with scale

Information on available spare parts:
www.boschrexroth.com/spc

Ordering code

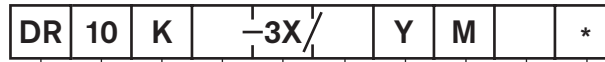

Pressure reducing valve, pilot operated = DR
 Size 10 = 10
 Cartridge valve = K
Type of adjustment
 Rotary knob = 4
 Sleeve with hexagon and protective cap = 5
 Lockable rotary knob with scale = 6¹⁾
 Rotary knob with scale = 7
 Component series 30 to 39 = 3X
 (30 to 39: unchanged installation and connection dimensions)

¹⁾ H-key with material no. **R900008158** is included in the scope of supply.

Further details in clear text

Seal material
 No code = NBR seals
 V = FKM seals
 (other seals on enquiry)
⚠ Caution!
 Observe compatibility of seals with hydraulic fluid used!

M = Without check valve
 Y = Pilot oil supply internal, Pilot oil drain external

Pressure stage
 50 = Secondary pressure up to 50 bar
 100 = Secondary pressure up to 100 bar
 200 = Secondary pressure up to 200 bar
 315 = Secondary pressure up to 315 bar

Standard types

Type	Material number
DR 10 K5-3X/50YM	R900422568
DR 10 K5-3X/100YM	R900459508
DR 10 K5-3X/200YM	R900438134
DR 10 K5-3X/315YM	R900430682

Type	Material number
DR 10 K5-3X/50YMV	R900430976
DR 10 K5-3X/100YMV	R900432731
DR 10 K5-3X/200YMV	R900438117
DR 10 K5-3X/315YMV	R900434144

Further standard types and components can be found in the EPS (standard price list).

Function, section, symbol

Pressure control valves of type DR 10 K.. are pilot operated pressure reducing valves for installation into manifolds. They are used to reduce a system pressure. The secondary pressure is adjusted by means of adjustment element (4).

In the initial position, the valves are open. Hydraulic fluid can flow from service port 2 to 1 without any restrictions. The pressure in service port 1 simultaneously acts on main spool (1) and via orifice (2) on the spring-loaded inner side of main spool (1). In addition, it acts on pilot poppet (8) via orifice (7). When the pressure in service port 1 rises above the value set on spring (5), pilot poppet (8) opens. Hydraulic fluid flows from

the chamber of spring (3) via orifice (7), pilot poppet (8) and spring chamber (6) to service port 3. Main spool (1) moves to the control position and keeps the pressure value set on spring (5) constant in service port 1.

The pilot oil is always externally drained from spring chamber (6) via service port 3.

Note!
 Backpressures (service port 3) add to the set pressure.

- ① = Service port 1 (A)
- ② = Service port 2 (B)
- ③ = Service port 3 (Y)

Type DR 10 K5-3X/.YM

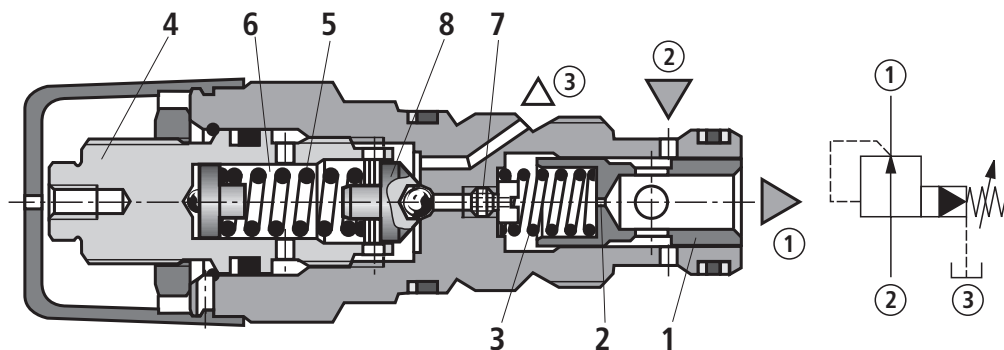

Technical data (for applications outside these parameters, please consult us!)

General		
Weight	kg	0.2
Installation orientation		Optional
Ambient temperature range	°C	-30 to +80 (NBR seals) -20 to +80 (FKM seals)
Hydraulic		
Maximum operating pressure ¹⁾ – Service port 2 (P)	bar	315
Secondary pressure – Service port 1 (A)	bar	50; 100; 200; 315
Max. permissible backpressure ¹⁾ – Service port 3 (T)	bar	315
Maximum flow	l/min	100
Hydraulic fluid		Mineral oil (HL, HLP) to DIN 51524 ²⁾ ; fast bio-degradable hydraulic fluids to VDMA 24568 (see also RE 90221); HETG (rape seed oil) ²⁾ ; HEPG (polyglycols) ³⁾ ; HEES (synthetic esters) ³⁾ ; other hydraulic fluids on enquiry
Hydraulic fluid temperature range	°C	-30 to +80 (NBR seals) -20 to +80 (FKM seals)
Viscosity range	mm ² /s	10 to 800
Max. permissible degree of contamination of the hydraulic fluid - cleanliness class to ISO 4406 (c)		Class 20/18/15 ⁴⁾

¹⁾ **⚠ Caution!** The maximum operating pressure is the sum of the secondary pressure and the backpressure!

²⁾ Suitable for NBR and FKM seals

³⁾ Suitable only for FKM seals

⁴⁾ The cleanliness classes specified for components must be adhered to in hydraulic systems. Effective filtration prevents malfunction and, at the same time, prolongs the service life of components.

For the selection of filters, see data sheets RE 50070, RE 50076, RE 50081, RE 50086 and RE 50088.

Characteristic curves (measured with HLP46, $\vartheta_{oil} = 40\text{ °C} \pm 5\text{ °C}$)

p_A - q_V characteristic curves

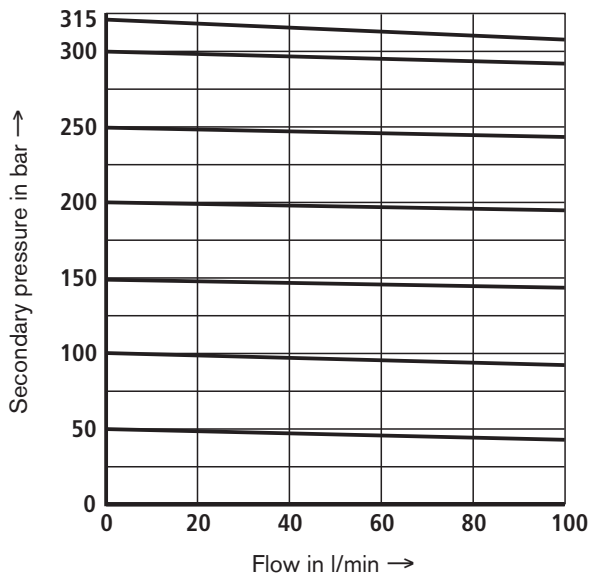

p_A - q_V characteristic curves
(within the range up to 50 bar)

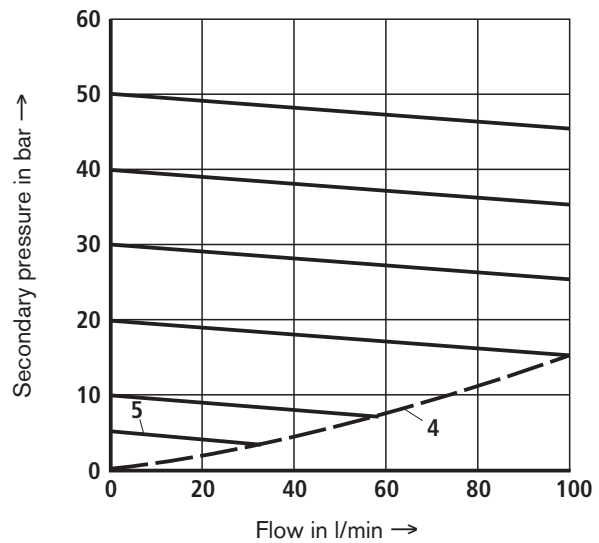

q_{Vst} - q_V characteristic curves at $\Delta p (p_E - p_A)$

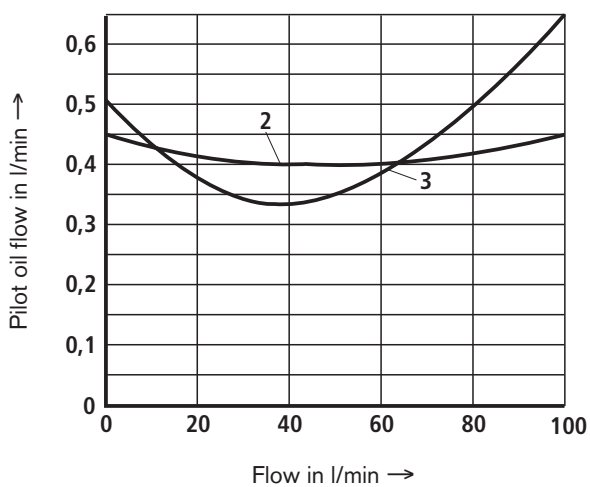

Δp_{min} - q_V characteristic curve

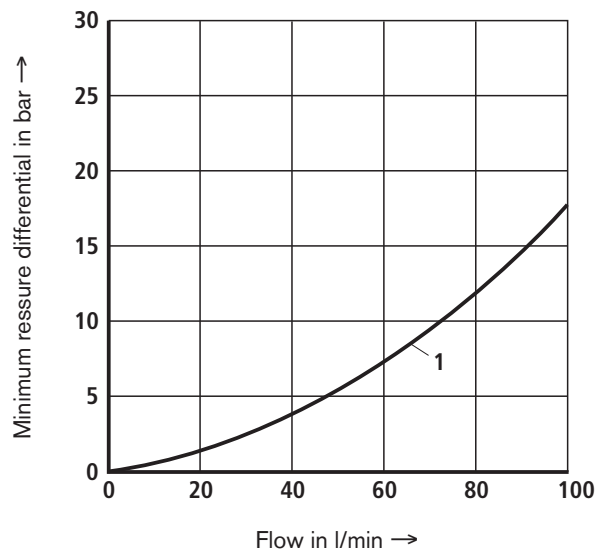

1	2 → 1 (P → A)
2	$\Delta p = 50\text{ bar}$
3	$\Delta p = 250\text{ bar}$
4	Actuator resistance, depending on system
5	Lowest settable secondary pressure p_A for all pressure stages

Unit dimensions (nominal dimensions in mm)

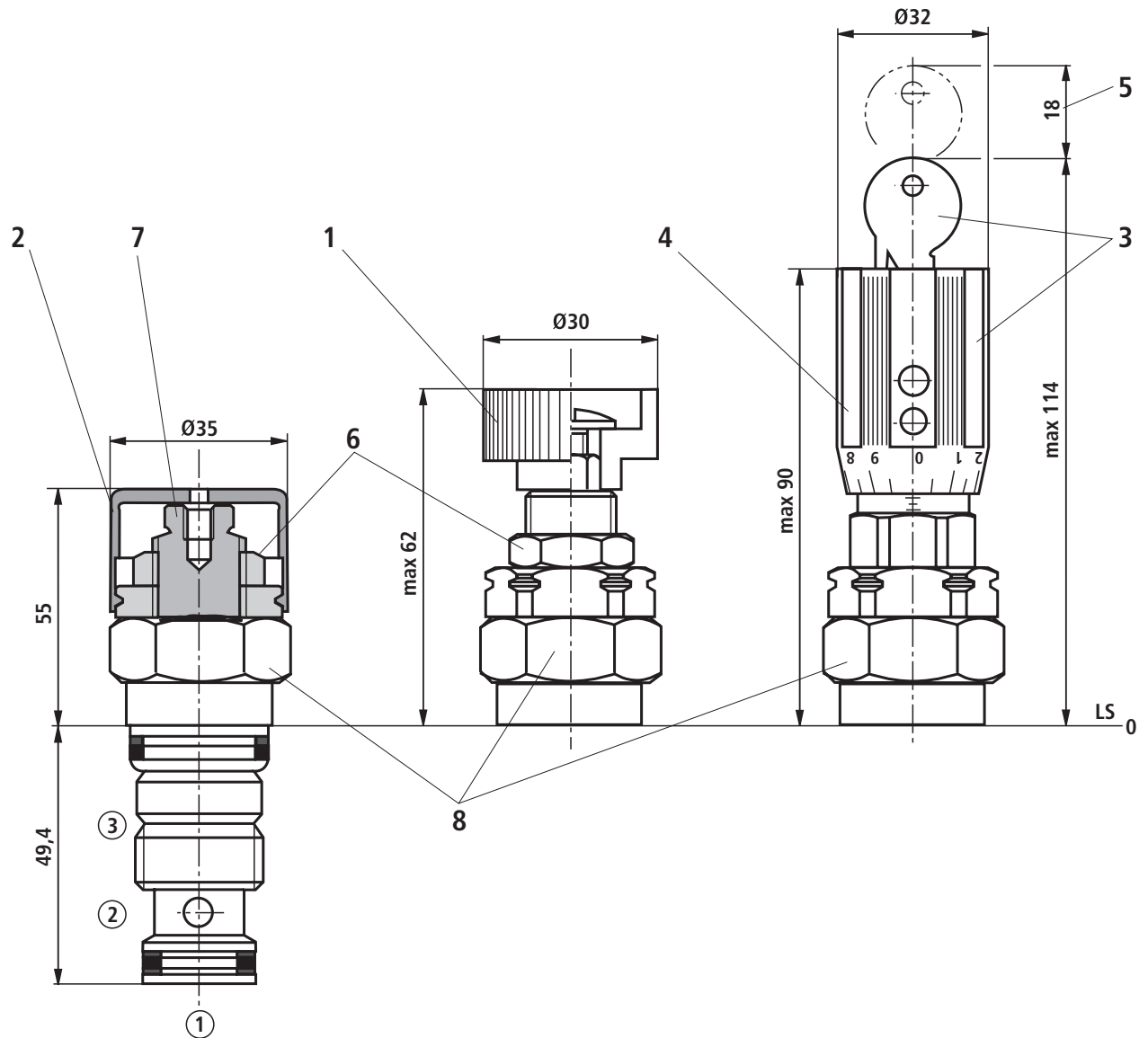

- 1 Type of adjustment "4"
- 2 Type of adjustment "5"
- 3 Type of adjustment "6"
- 4 Type of adjustment "7"
- 5 Space required to remove key
- 6 Locknut A/F 24
- 7 Hexagon A/F 10
- 8 Hexagon A/F 30, tightening torque for screwing in
 $M_T = 50 \text{ Nm}$

- ① = Service port 1 (A)
- ② = Service port 2 (P)
- ③ = Service port 3 (Y)
- LS = Location Shoulder

Mounting cavity; 3 service ports; thread M24 x 1 (nominal dimensions in mm)

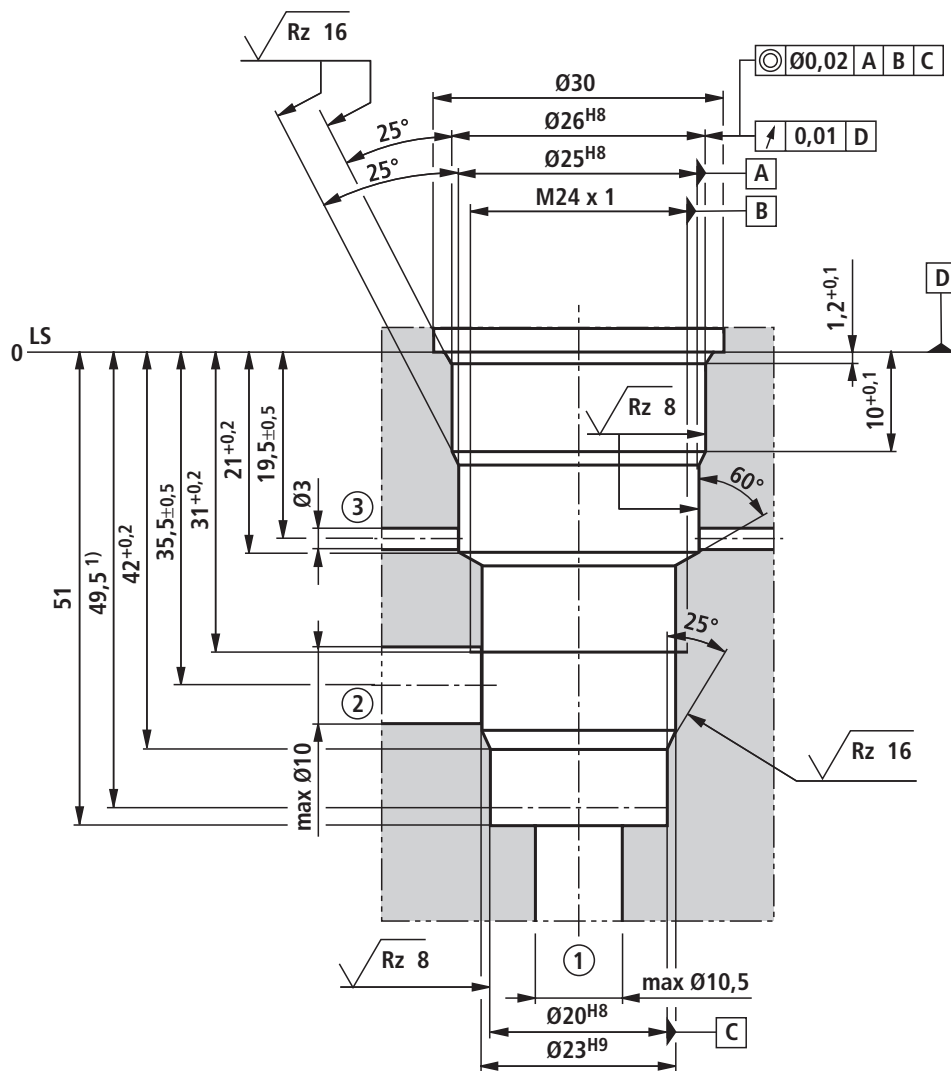

- ① = Service port 1 (A)
- ② = Service port 2 (P), can be arranged optionally around the circumference
- ③ = Service port 3 (Y), can be arranged optionally around the circumference

LS = Location Shoulder

¹⁾ Depth of fit

Bosch Rexroth AG
Hydraulics
Zum Eisengießer 1
97816 Lohr am Main, Germany
Phone +49 (0) 93 52 / 18-0
Fax +49 (0) 93 52 / 18-23 58
documentation@boschrexroth.de
www.boschrexroth.de

© This document, as well as the data, specifications and other information set forth in it, are the exclusive property of Bosch Rexroth AG. It may not be reproduced or given to third parties without its consent.

The data specified above only serve to describe the product. No statements concerning a certain condition or suitability for a certain application can be derived from our information. The information given does not release the user from the obligation of own judgment and verification. It must be remembered that our products are subject to a natural process of wear and aging.

Notes

Bosch Rexroth AG
Hydraulics
Zum Eisengießer 1
97816 Lohr am Main, Germany
Phone +49 (0) 93 52 / 18-0
Fax +49 (0) 93 52 / 18-23 58
documentation@boschrexroth.de
www.boschrexroth.de

© This document, as well as the data, specifications and other information set forth in it, are the exclusive property of Bosch Rexroth AG. It may not be reproduced or given to third parties without its consent.

The data specified above only serve to describe the product. No statements concerning a certain condition or suitability for a certain application can be derived from our information. The information given does not release the user from the obligation of own judgment and verification. It must be remembered that our products are subject to a natural process of wear and aging.

Notes

Bosch Rexroth AG
Hydraulics
Zum Eisengießer 1
97816 Lohr am Main, Germany
Phone +49 (0) 93 52 / 18-0
Fax +49 (0) 93 52 / 18-23 58
documentation@boschrexroth.de
www.boschrexroth.de

© This document, as well as the data, specifications and other information set forth in it, are the exclusive property of Bosch Rexroth AG. It may not be reproduced or given to third parties without its consent.

The data specified above only serve to describe the product. No statements concerning a certain condition or suitability for a certain application can be derived from our information. The information given does not release the user from the obligation of own judgment and verification. It must be remembered that our products are subject to a natural process of wear and aging.