

Pressure reducing valve, pilot operated

Type DR

RE 26893

Edition: 2013-01

Replaces: 02.03



H7928

- ▶ Sizes 10 and 25
- ▶ Component series 1X; 4X
- ▶ Maximum operating pressure 315 bar
- ▶ Maximum flow 160 l/min

Features

- ▶ For subplate mounting
- ▶ Porting pattern according to ISO 5781
- ▶ For threaded connection
- ▶ As screw-in cartridge valve
- ▶ 4 adjustment types, optionally:
 - Rotary knob
 - Bushing with hexagon and protective cap
 - Lockable rotary knob with scale
 - Rotary knob with scale
- ▶ 4 pressure ratings

Contents

Features	1
Ordering code	2
Symbols	3
Function, section	4
Technical data	5
Characteristic curves	6, 7
Unit dimensions	8 ... 12
Mounting cavity	11
More information	12

Ordering code

01	02	03	04	05	06	07	08	09	10
DR		-	-	/		Y			*

01	Pressure reducing valve	DR
02	- Size 10	
	Subplate mounting "no code"	10
	Threaded connection "G" (G1/2)	10
	- Size 25	
	Subplate mounting "no code"	20
	Threaded connection "G" (G3/4)	15
	Threaded connection "G" (G1)	20
	Screw-in cartridge valve "K"	20

Type of connection

03	Subplate mounting	no code
	Threaded connection	G
	Screw-in cartridge valve	K

Adjustment type

04	Rotary knob	4
	Bushing with hexagon and protective cap	5
	Lockable rotary knob with scale	6 ¹⁾
	Rotary knob with scale	7
05	Component series 10 to 19 (10 to 19: Unchanged installation and connection dimensions); (03 = "K")	1X
	Component series 40 to 49 (40 to 49: Unchanged installation and connection dimensions); (03 = "no code" and "G")	4X

Pressure rating

06	Set pressure up to 50 bar	50
	Set pressure up to 100 bar	100
	Set pressure up to 200 bar	200
	Set pressure up to 315 bar	315
07	Pilot oil supply internal, pilot oil return external	Y
08	With check valve (subplate mounting only)	no code
	Without spring return	M

Seal material

09	NBR seals	no code
	FKM seals	V
	Attention: Observe compatibility of seals with hydraulic fluid used! (Other seals upon request)	
10	Further details in the plain text	

¹⁾ H-key with the material no. **R900008158** is included in the scope of delivery.

 **Notice!** Preferred types and standard units are contained in the EPS (standard price list).

Symbols

Subplate mounting

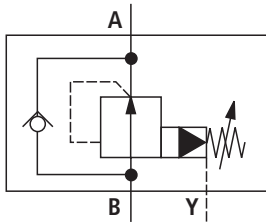

Type DR . .-.4X/.Y

**Subplate mounting
screw-in cartridge valve**

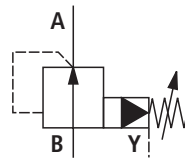

Type DR . .-.4X/.YM
Type DR . K-.1X/.YM (screw-in cartridge valve)

Threaded connection

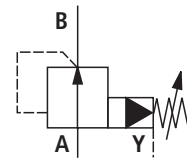

Type DR . G-.4X/.YM

Function, section

The pressure valve type DR is a pilot operated pressure reducing valve. It is used to reduce the system pressure. It mainly consists of screw-in cartridge valve (cartridge) and housing, optionally with or without check valve (subplate mounting only).

In the rest position the valve is open. The hydraulic fluid is able to flow freely from the input channel via the main control spool (1) to the output channel. The pressure in the output channel is applied to the spring-loaded side of the main control spool (1) via the bore (2). At the same time, the pressure acts upon the side of the main control spool (1) that is opposite to the spring via the bores (3) and (4).

If the pressure in the output channel exceeds the value set at the spring (6), the pilot poppet (5) opens. Hydraulic fluid flows from the spring-loaded side of the main control spool (1) via the nozzle (7) and the pilot poppet (5) into the spring chamber (8).

The main control spool (1) assumes its control position and keeps the value in the output channel set at the spring (6) constant. The pilot oil return from the spring chamber (8) is always effected externally via the Y port (9).

In the subplate mounting "P" version, a check valve (10) can be optionally installed for free flow back from channel A to B.

Notice!

The pressure in port Y is added 1:1 to the set reduced pressure.

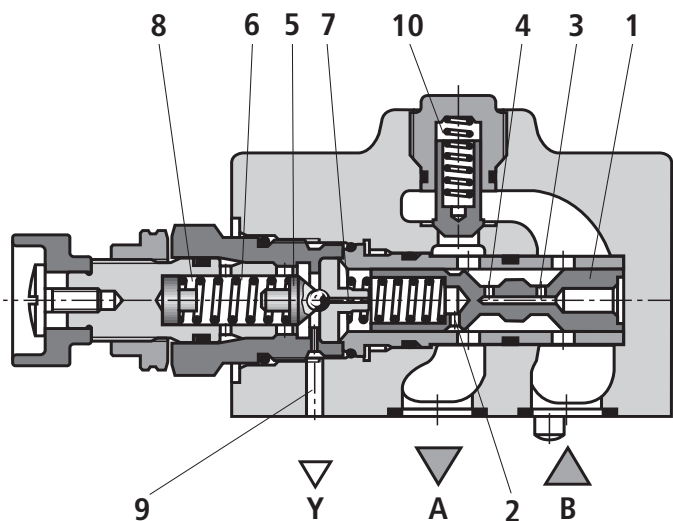

Type DR 10 -4-4X/...

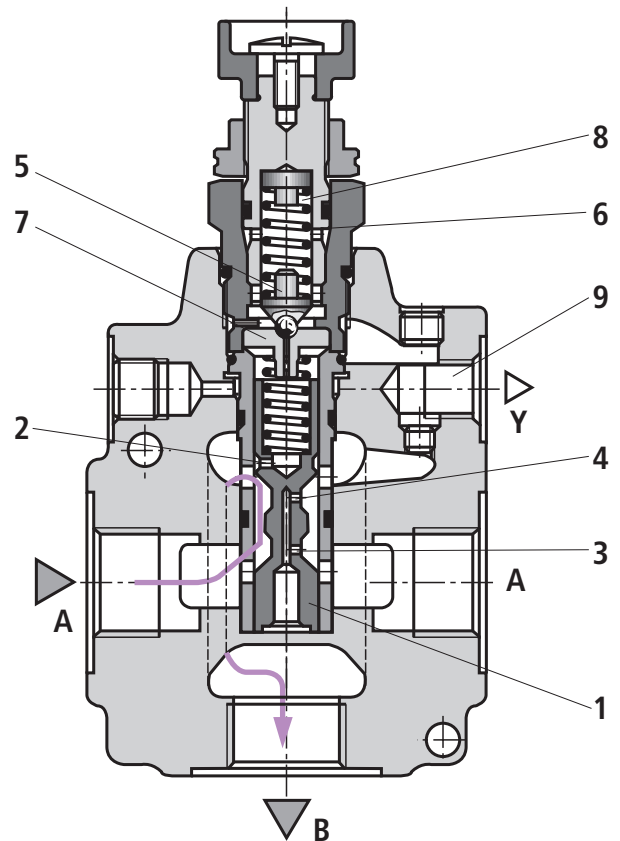

Type DR 20 G-4-4X/...

Technical data

(For applications outside these parameters, please consult us!)

general			
Size	Size	10	25
Weight	- Subplate mounting	kg	3.2
	- Threaded connection	kg	3.6
	- Screw-in cartridge valve	kg	2.5
Installation position		Any	
Ambient temperature range	°C	-30 ... +80 (NBR seals) -20 ... +80 (FKM seals)	

hydraulic			
Nominal pressure	bar	315	
Maximum operating pressure	- Input	bar	315
Maximum secondary pressure	- Output	bar	50; 100; 200; 315
Maximum counter pressure	- Port Y	bar	250
Set pressure	- Minimum	bar	Flow-dependent (see characteristic curves page 6)
	- Maximum	bar	50; 100; 200; 315
Maximum flow	- Subplate mounting	l/min	80
	- Threaded connection	l/min	80
Hydraulic fluid		See table below	
Hydraulic fluid temperature range	°C	-30 ... +80 (NBR seals) -20 ... +80 (FKM seals)	
Viscosity range	mm ² /s	10 ... 800	
Maximum permitted degree of contamination of the hydraulic fluid - cleanliness class according to ISO 4406 (c)		Class 20/18/15 ¹⁾	

Hydraulic fluid	Classification	Suitable sealing materials	Standards
Mineral oils	HL, HLP	NBR, FKM	DIN 51524
Bio-degradable	- insoluble in water	HETG	VDMA 24568
		HEES	
	- soluble in water	HEPG	VDMA 24568
Flame-resistant	- water-free	HFDU	ISO 12922
	- containing water	HFC (Fuchs Hydrotherm 46M, Petrofer Ultra Safe 620)	NBR ISO 12922

Important information on hydraulic fluids!

- ▶ For more information and data on the use of other hydraulic fluids refer to data sheet 90220 or contact us!
- ▶ There may be limitations regarding the technical valve data (temperature, pressure range, life cycle, maintenance intervals, etc.)!
- ▶ The flash point of the hydraulic fluid used must be 40 K higher than the maximum surface temperature.

▶ Flame-resistant – containing water:

- Maximum pressure differential per control edge 210 bar, otherwise, increased cavitation erosion
- Maximum hydraulic fluid temperature 60 °C
- Life cycle as compared to operation with mineral oil HLP 30 to 100 %

¹⁾ The cleanliness classes specified for the components must be adhered to in hydraulic systems. Effective filtration prevents faults and at the same time increases the life cycle of the components. For the selection of the filters see www.boschrexroth.com/filter.

Characteristic curves

(measured with HLP46, $\vartheta_{oil} = 40 \pm 5 \text{ } ^\circ\text{C}$)

Output pressure p_A dependent on the flow q_V (B to A)

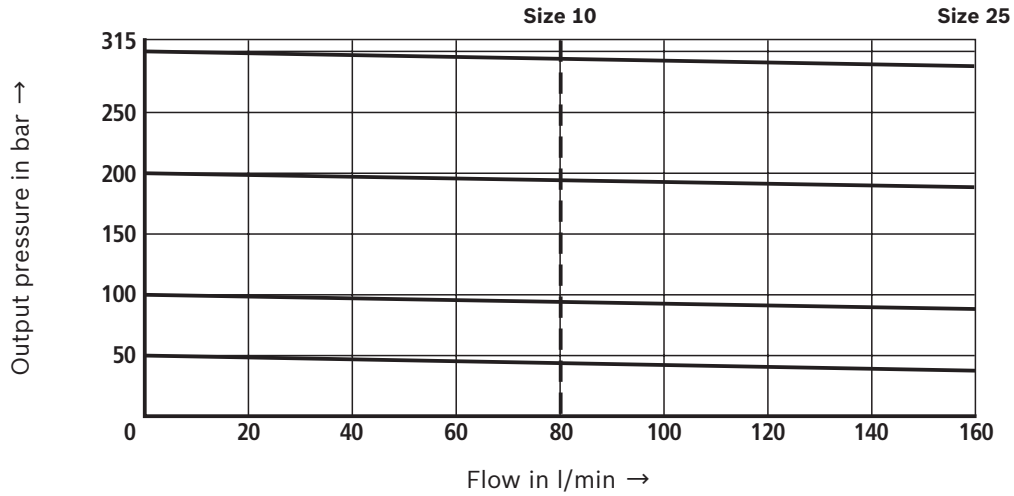

Minimum adjustable output pressure $p_{A \min}$ dependent on the flow q_V (B to A)

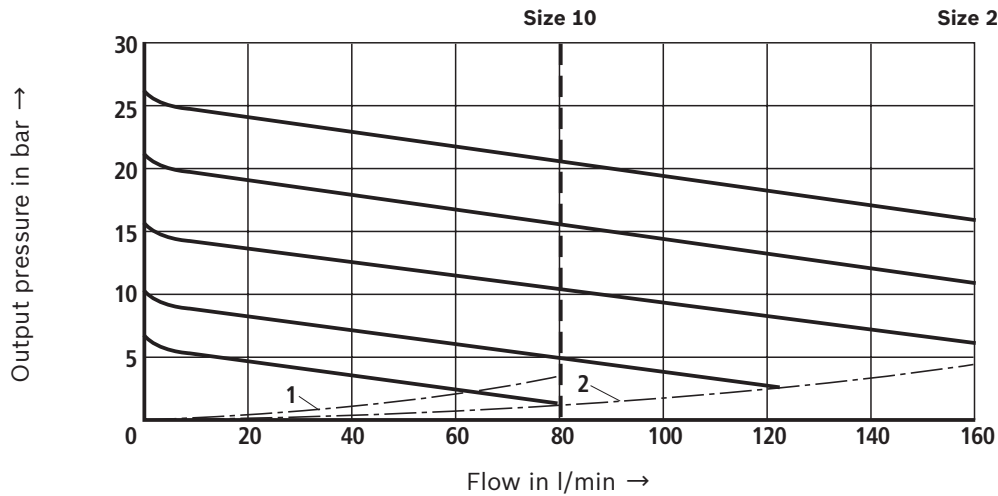

Performance limit (system-dependent):

- 1 Size 10
- 2 Size 25

Characteristic curves

(measured with HLP46, $\vartheta_{oil} = 40 \pm 5 \text{ }^\circ\text{C}$)

Pilot flow q_{Vst} dependent on the flow q_V (B to A) and the pressure differential Δp

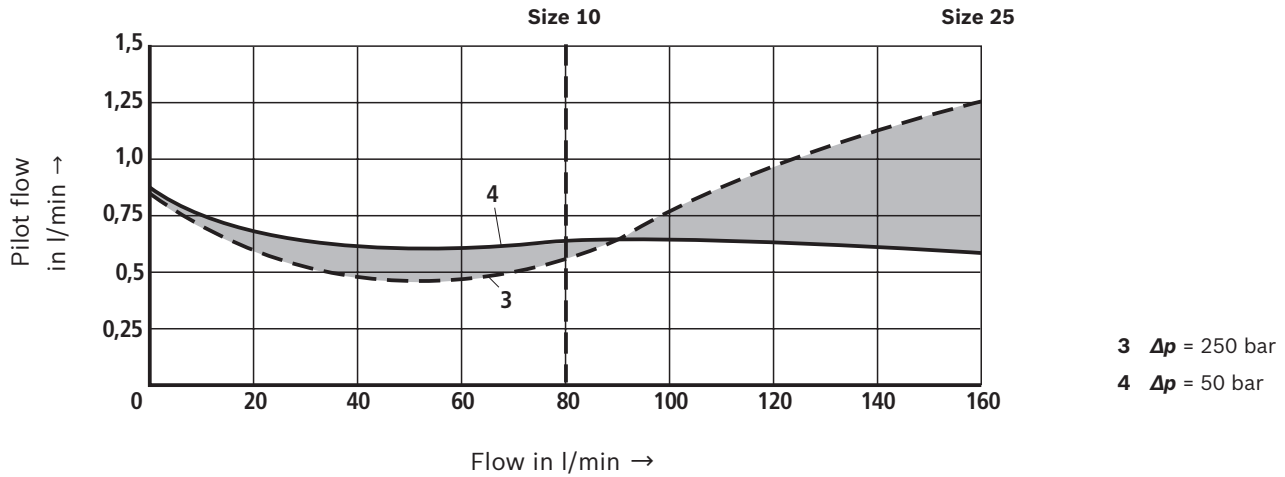

$\Delta p_{min} \cdot q_V$ characteristic curve (B to A)

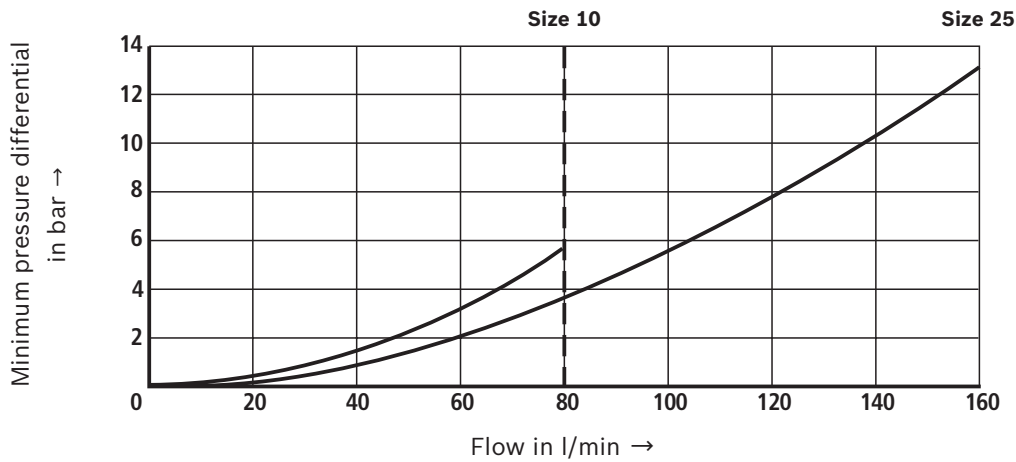

$\Delta p \cdot q_V$ characteristic curve (B to A)

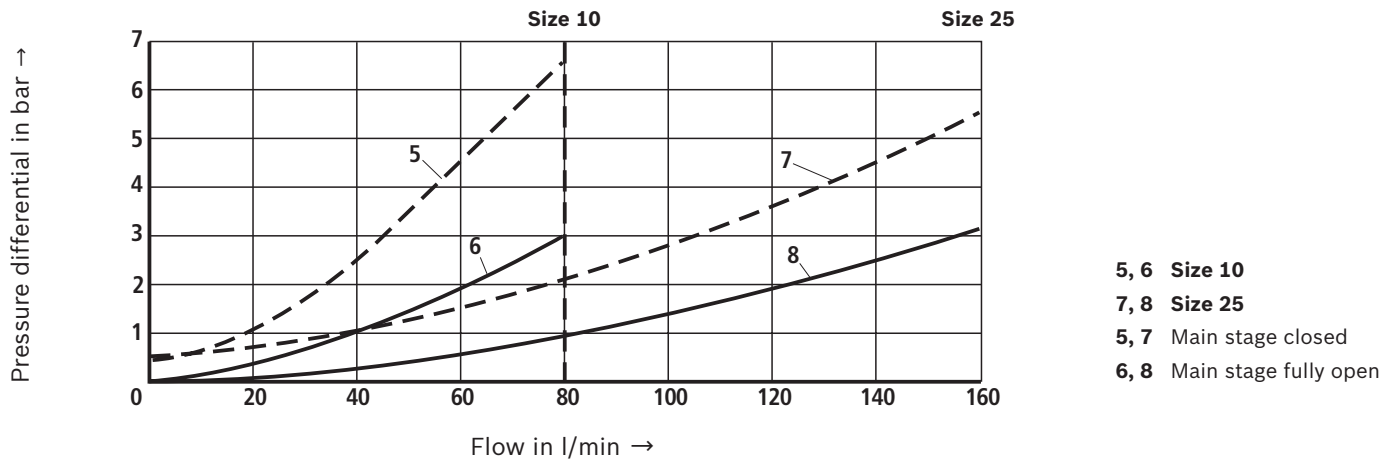

Unit dimensions: Subplate mounting
(dimensions in mm)

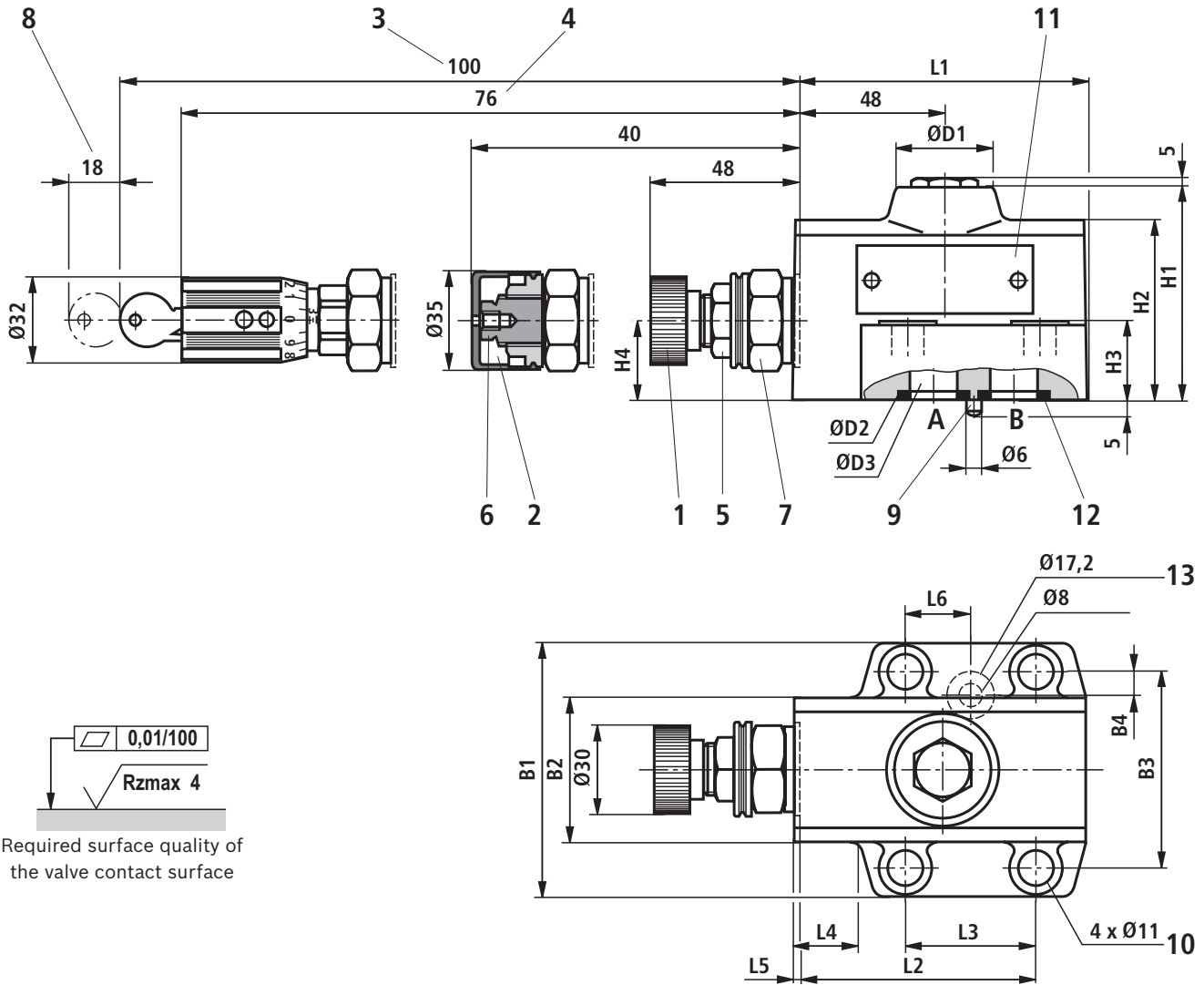

Type	L1	L2	L3	L4	L5	L6	B1	B2	B3	B4	H1	H2	H3	H4	ØD1	ØD2	ØD3
DR 10	95.5	79	42.9	23	2.5	21.5	85	49	66.7	7.9	71	60	26	26	35.5	21.8	15
DR 20	96	79.5	60.3	7	4	39.7	100	58	79.4	6.4	96	78	26	40	41	34.8	25

Item explanations, subplates, and valve mounting screws see page 12.

Unit dimensions: Threaded connection "G"
(dimensions in mm)

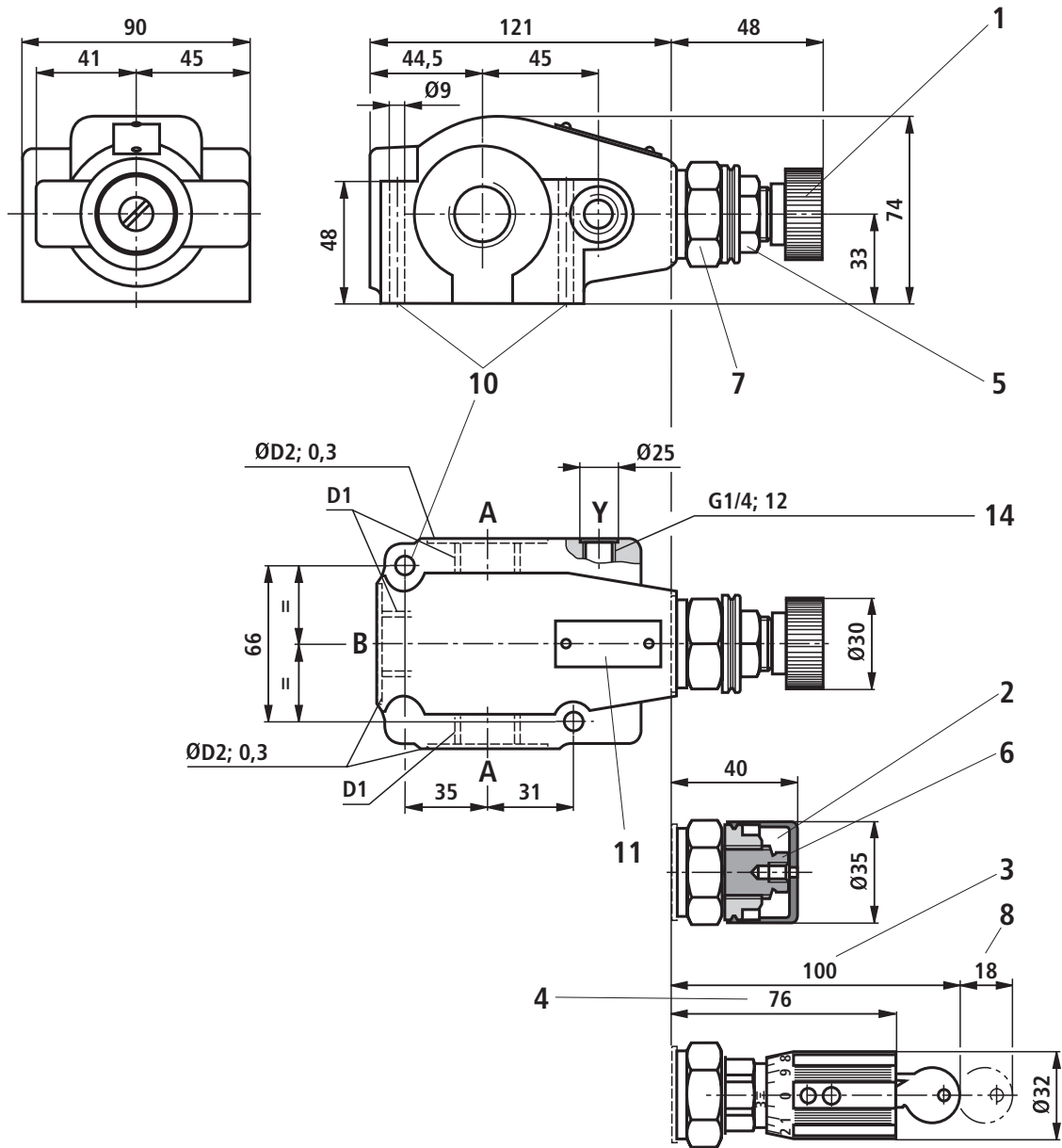

Type	D1	$\varnothing D2$
DR 10 G	G1/2	34
DR 15 G	G3/4	42
DR 20 G	G1	47

Notice!

In this valve version, **no** check valve for free return flow is installed in the valve.

Item explanations, subplates, and valve mounting screws see page 12.

Unit dimensions: Screw-in cartridge valve "K"
(dimensions in mm)

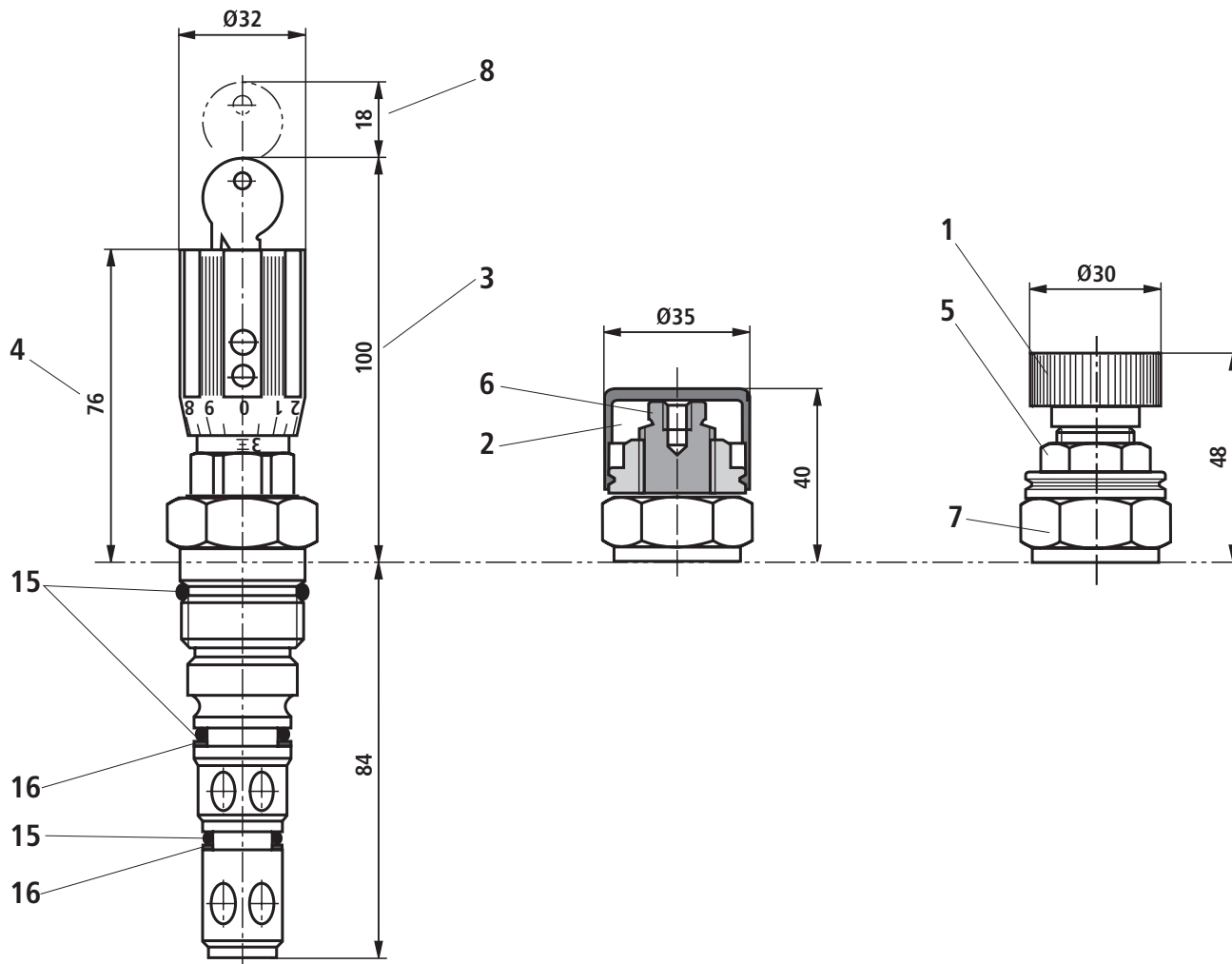

- 1 Adjustment type "4"
- 2 Adjustment type "5"
- 3 Adjustment type "6"
- 4 Adjustment type "7"
- 5 Lock nut SW22
- 6 Hexagon SW10
- 7 Hexagon SW30, tightening torque when screwing in
 $M_A = 50 \text{ Nm}$
- 8 Space required to remove the key
- 15 Seal ring
- 16 Support ring

Mounting cavity
(dimensions in mm)

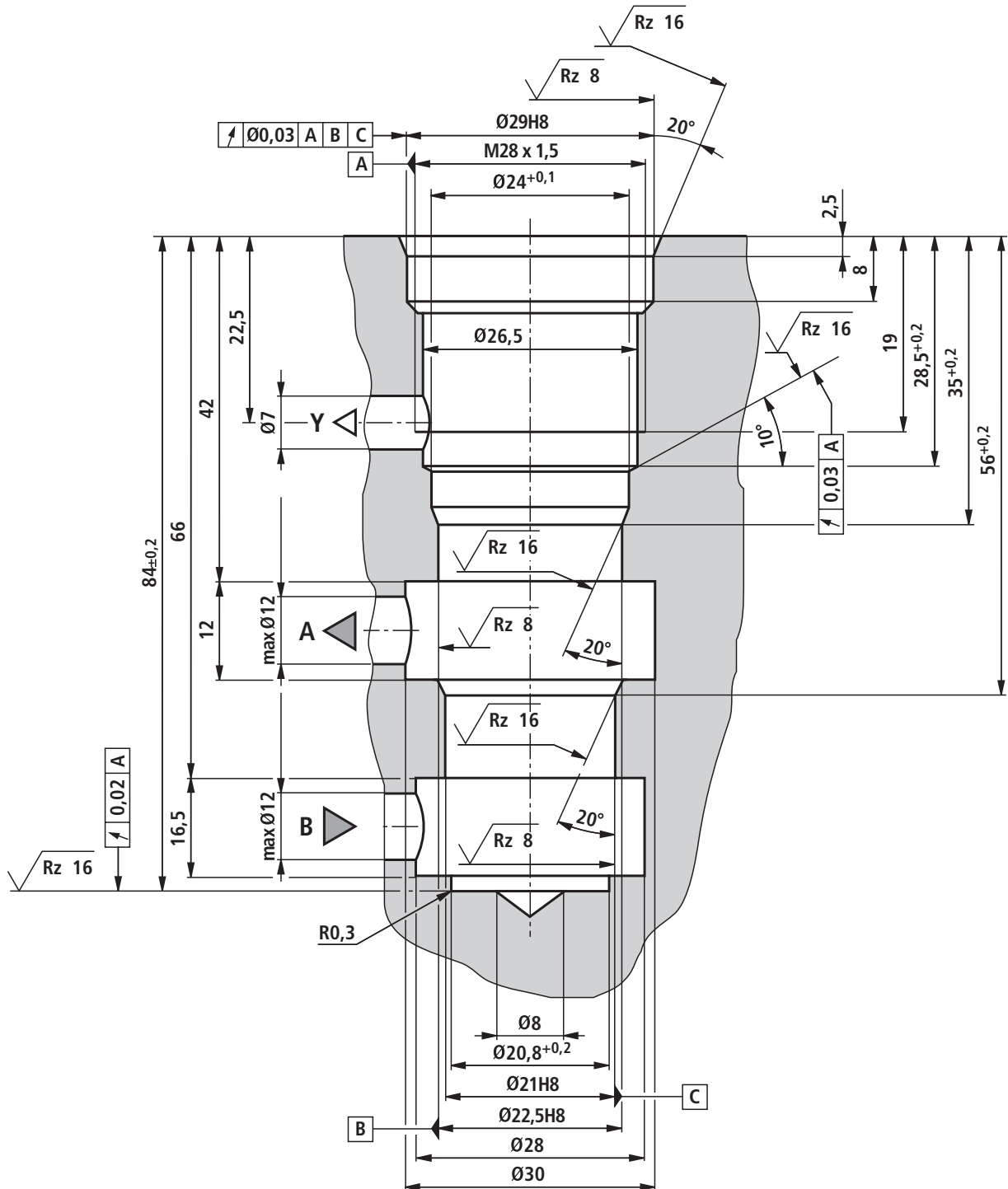

Notice!

Optionally, the connection bores A, B and Y can be applied at the circumference.

Unit dimensions

- 1 Adjustment type "4"
- 2 Adjustment type "5"
- 3 Adjustment type "6"
- 4 Adjustment type "7"
- 5 Lock nut SW22
- 6 Hexagon SW10
- 7 Hexagon SW30, tightening torque when screwing in
 $M_A = 50 \text{ Nm}$
- 8 Space required to remove the key
- 9 Locking pin
- 10 Valve mounting bores
- 11 Name plate
- 12 Identical seal rings for ports A and B
- 13 Seal ring for port Y
- 14 Y port for pilot oil return

Subplates according to data sheet 45062 (separate order)

- ▶ Size 10:
G 460/01 (G3/8)
G 461/01 (G1/2)
- ▶ Size 25:
G 412/01 (G3/4)
G 413/01 (G1)

Valve mounting screws (separate order)

- ▶ Size 10:
4 hexagon socket head cap screws
ISO 4762 - M10 x 40 - 10.9-flZn-240h-L
(friction coefficient $\mu_{\text{total}} = 0.09$ to 0.14);
Tightening torque $M_A = 75 \text{ Nm} \pm 10 \%$
- ▶ Size 25:
4 hexagon socket head cap screws
ISO 4762 - M10 x 50 - 10.9-flZn-240h-L
(friction coefficient $\mu_{\text{total}} = 0.09$ to 0.14);
Tightening torque $M_A = 75 \text{ Nm} \pm 10 \%$

Notice!

The tightening torques stated are guidelines when using screws with the specified friction coefficients and when using a manual torque wrench (tolerance $\pm 10 \%$).

More information

- ▶ Subplates
- ▶ Hydraulic fluids on mineral oil basis
- ▶ Reliability characteristics according to EN ISO 13849
- ▶ General product information on hydraulic products
- ▶ Installation, commissioning and maintenance of industrial valves
- ▶ Selection of the filters

Data sheet 45062

Data sheet 90220

Data sheet 08012

Data sheet 07008

Data sheet 07300

www.boschrexroth.com/filter

Bosch Rexroth AG
Hydraulics
Zum Eisengießer 1
97816 Lohr am Main, Germany
Phone +49 (0) 93 52/18-0
documentation@boschrexroth.de
www.boschrexroth.de

© This document, as well as the data, specifications and other information set forth in it, are the exclusive property of Bosch Rexroth AG. It may not be reproduced or given to third parties without its consent.

The data specified above only serve to describe the product. No statements concerning a certain condition or suitability for a certain application can be derived from our information. The information given does not release the user from the obligation of own judgment and verification.

It must be remembered that our products are subject to a natural process of wear and aging.